



*Climate Control Solutions*

# Literature Assembly

## 911-0864

Contains the following:

2100-775	IZ Econ Installation Manual
2110-1148	Replacement Parts
4204-112(A)	Wiring Diagram



---

# OPERATION INSTRUCTIONS

---

## Full Flow Modulating Low Leakage Economizer with Power Exhaust

Model: IZ ECONOMIZER

For Use with Bard I-TEC® Heat Pump Models:  
I36Z2, I42Z2, I48Z2, I60Z2



Bard Manufacturing Company, Inc.  
Bryan, Ohio 43506  
[www.bardhvac.com](http://www.bardhvac.com)

Manual: 2100-775  
Supersedes: **NEW**  
Date: 2-27-23

# CONTENTS

---

<b>General Information .....</b>	<b>3</b>
General Economizer Information .....	3
Basic Operation Using the JADE W7220 with 2-Speed Fan and Motorized Exhaust .....	3
JADE™ Controller Technical Specifications.....	3
Environmental Information .....	3
Electrical Information .....	3
Sensors .....	4
<b>Start Up .....</b>	<b>5</b>
JADE Economizer Controller .....	5
Economizer Quick Start.....	5
Quick Start Basic JADE Economizer Control Setup (SETPOINTS Menu) .....	5
Outdoor Temperature or Humidity Adjustment Procedure.....	5
Minimum Position Setting.....	6
Low Outdoor Temperature Compressor Lockout.....	6
Mixed Air Temperature Setting.....	6
Operational Checkout (CHECKOUT Menu) .....	6
Checkout Procedure.....	6
Economizer Exhaust .....	7
Exhaust Fan Off Delay Timer.....	8
JADE Economizer Control Advanced Setup.....	8
Review/Customize System Setup.....	8
DVC with 2-Speed Fan .....	10
Enthalpy Settings .....	11
Economizer Sequence of Operation .....	13
Condition – Cool/Dry OA Conditions.....	13
Condition – Warm/Humid OA Conditions .....	13
Service .....	14
Exhaust Damper and Actuator.....	14
Intake Actuator .....	14
2-Stage Compressor Units – Economizer Operation Part and Full Load Operation .....	18
Default Tables .....	21

## TABLES

Table 1	Bard System Setup .....	8
Table 2	Bard Advanced Setup.....	9
Table 3	Bard Setpoints.....	9
Table 4	Status Menu Levels.....	10
Table 5	Alarm Examples.....	10
Table 6	Unit Operation with Economizer Options .....	17
Table 7A	Menu Structure.....	21
Table 7B	Menu Structure.....	22
Table 7C	Menu Structure.....	23
Table 7D	Menu Structure.....	24
Table 7E	Menu Structure.....	25
Table 7F	Menu Structure.....	26
Table 7G	Menu Structure.....	27
Table 8	Damper Minimum Position Settings and Readings on Checkout Menu.....	27
Table 9	Dry Bulb Operation No DCV (CO <sub>2</sub> Sensor) – 2 Speed Fan .....	28
Table 10	Dry Bulb Operation w/DCV (CO <sub>2</sub> Sensor) – 2 Speed Fan .....	28
Table 11	Enthalpy Operation No DCV (CO <sub>2</sub> Sensor) – 2 Speed Fan .....	29
Table 12	Enthalpy Operation w/DCV (CO <sub>2</sub> Sensor) – 2 Speed Fan .....	29

## FIGURES

Figure 1	JADE Economizer Controller .....	5
Figure 2	2-Speed Fan Operation.....	7
Figure 3	Exhaust Fan Speed Control Board.....	7
Figure 4	Exhaust Fan Off Delay Timer .....	8
Figure 5	Enthalpy Curve Settings.....	11
Figure 6	CO <sub>2</sub> Sensor Default and Final Settings Bard P/N 8403-096 CO <sub>2</sub> Controller.....	12
Figure 7	Vent Airflow Path .....	13
Figure 8	Exhaust Damper Actuator Access.....	14
Figure 9	Intake Damper Actuator Access .....	15
Figure 10	Programmable Thermostat Connections for ECON-***5 w/2-Stage Heat Pumps ..	16

## GRAPHS

Graph 1	I36Z2 Ventilation Delivery.....	19
Graph 2	I42Z2 Ventilation Delivery.....	19
Graph 3	I48Z2 Ventilation Delivery.....	20
Graph 4	I60Z2 Ventilation Delivery.....	20

## General Economizer Information

Using an economizer provides economical cooling without the need for running the compressor and refrigeration system when outdoor conditions are acceptable to bring air into the building. By bringing in outdoor air to cool a building, energy use is reduced to the power required to operate the indoor fan and the economizer controls. Energy use is a fraction of the power required to operate the refrigeration system. The following benefits can be attributed to the economizer:

- Reduced energy costs when outdoor conditions are acceptable to bring air into the building.
- Lengthen the life expectancy of the refrigeration components due to lower operating time.
- Provide a source of air for an occupied area to meet building code requirements.
- Reduce stress to refrigeration equipment during extremely cold outdoor temperatures by using outdoor air to cool.

Economizer usage is beneficial for several applications including equipment cooling and keeping occupants comfortable while keeping energy costs at a minimum.

The IZ factory-installed economizer uses the Honeywell JADE® W7220 control, low leakage intake and exhaust dampers and direct-drive actuators. The economizer uses a supply/mixed air sensor and outdoor changeover sensor (either dry bulb or enthalpy sensor).

There are two distinct types of economizers that are factory provided:

- The "fixed dry bulb" economizer allows outdoor air to enter the building when the outdoor temperature monitored by an outdoor sensor is below the user-selectable outdoor temperature setpoint in the JADE controller. Economizer cooling operation is based on outdoor temperature only.
- The "fixed dry bulb and enthalpy" economizer allows outdoor air to enter the building when the outdoor temperature and humidity monitored by an outdoor sensor is below the user-selectable enthalpy curve in the JADE controller. Economizer cooling operation is based on outdoor temperature and humidity.

Either of the above economizers can be converted to differential dry bulb or differential enthalpy by adding the field-installed return air sensor kit.

### Basic Operation Using the JADE W7220 with 2-Speed Fan and Motorized Exhaust

For occupied mode operation, the A terminal is energized with 24 volts at the unit low voltage terminal strip. At the same time, this powers G at the unit low

voltage terminal strip and the OCC input at the W7220 which will command the fresh air damper to open to the minimum damper position setting and the supply air fan to low speed.

If there is a call for cooling, Y1 is energized at the low voltage control board. If the outdoor temperature is below the setpoint of the outdoor sensor, the fresh air damper will open and attempt to cool the indoor space by using outdoor air while attempting to maintain the mixed air sensor setpoint "fixed dry bulb". At the same time, when the fresh air damper reaches the exhaust fan setpoint, the exhaust damper will open and exhaust fan will start.

If the call for cooling is not satisfied, Y2 at the low voltage control board is energized and 1st stage mechanical cooling along with economizer will attempt to satisfy the thermostat. If the thermostat is not satisfied after 30 minutes, 2nd stage cooling is energized. If free cooling using outdoor air is not available, the unit cooling sequence will be controlled directly by the space thermostat and mechanical cooling.

W7220 stages are:

1st Stage – Low speed supply blower

2nd Stage – 1st stage compressor

3rd Stage – 2nd stage compressor

## JADE W7220 Controller Technical Specifications

The economizer system ships with standard settings pre-programmed from the factory. Normal use and operation may not require adjustments to the JADE settings. Advanced applications, however, may require additional setup and feature selection. The JADE model W7220 is used widely in the field, and heavily supported by the manufacturer. It is important to note that Bard does custom program the JADE for specific economizer models. If replacing the JADE is necessary, always order the JADE controller based on the Bard part number.

### Environmental Information

Operating Temperature: -40 to 150°F (-40 to 65°C).  
Exception of display operation down to -4°F with full recovery at -4°F from exposure to -40°F.

Storage Temperature: -40 to 150°F (-40 to 65°C)

Shipping Temperature: -40 to 150°F (-40 to 65°C)

Relative Humidity: 5% to 95% RH non-condensing

### Electrical Information

Rated Voltage: 20 to 30 VAC RMS; 50/60 Hz

Nominal Power Consumption (at 24 VAC, 60 Hz): 11.5 VA without sensors and actuator

Relay Contact Rating at 30 VAC (maximum power from Class 2 input only): 1.5A run; 3.5A inrush @ 0.45PF (200,000 cycles) or 7.5A inrush @ 0.45PF (100,000 cycles)

External Sensors Power Output: 21 VDC +/- 5% @ 48mA

### **Sensors**

Dry Bulb Sensor Temperature Range: -40 to 150°F (-40 to 65°C)

Temperature and Humidity Sensor Range: Temperature -40 to 150°F (-40 to 65°C), humidity 0 to 100% RH with 5% accuracy.

Optional CO<sub>2</sub> Sensor Input: 2-10 VDC control signal; minimum impedance >50k ohm.

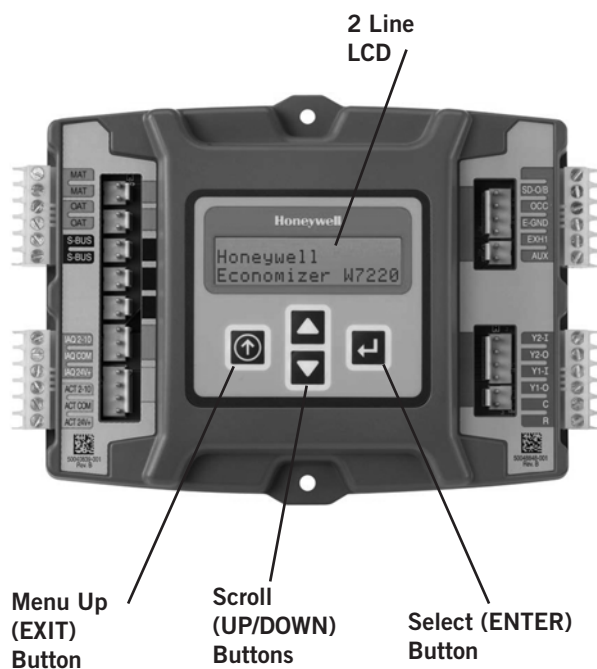
## JADE Economizer Controller

The JADE W7220 controller offers unparalleled flexibility and expansion in a dependable and solid electronic platform.

- Multiple economizer applications from one controller.
- Nearly limitless customization of setpoints.
- Internal checkout menu provides fast performance assessment.
- Alarms menu provides assistance in troubleshooting.

**Memory:** User-defined setpoints remain in non-volatile flash memory regardless of electrical outage duration. Control voltage below 18V may cause erratic performance.

**FIGURE 1**  
**JADE Economizer Controller**



From the factory, the JADE economizer controller has been preset with “default” values that were pre-determined as optimum for equipment buildings, and these are shown in Tables 1 – 3 (on pages 8 and 9). However, it is important to review and/or customize these operational values per owner specifications in order to guarantee satisfactory performance.

The installing contractor can easily access the JADE programming by the integral keypad and LCD display.

There are six (6) basic MENU categories to navigate:

1. **STATUS** – provides real-time access to sensor input, damper and equipment operation.
2. **SETPOINTS** – customizable operational parameters.
3. **SYSTEM SETUP** – customizable application programming (see **Review/Customize System Setup**).
4. **ADVANCED SETUP** – further application and operational options.
5. **CHECKOUT** – instantly activate and verify economizer functions.
6. **ALARMS** – displays alarms and pinpoints problem areas.

## Economizer Quick Start

### Quick Start Basic JADE Economizer Control Setup (SETPOINTS Menu)

This Bard IZ economizer is shipped with Bard settings pre-programmed into the JADE controller, which includes 2-speed fan operation. The SETPOINTS menu allows for basic user adjustment of several features including the following:

#### Outdoor Temperature or Humidity Adjustment Procedure

- Units with "differential dry bulb" economizers are operated based on outdoor temperature only. The economizer will operate regardless of outdoor humidity. To adjust the outdoor temperature setting in the JADE controller that will initiate economizer operation, navigate to the SETPOINTS menu using the UP/DOWN buttons. Next, navigate to the DRYBULB SET menu using the UP/DOWN buttons. The default dry bulb setpoint is 70°F (21.1°C). The range of this setting is 48°F (8.8°C) to 80°F (26.6°C). Bard recommends gradual adjustment of the outdoor dry bulb setpoint if adjustment is necessary. It is always important to consider the indoor temperature requirements while maximizing economizer run time when adjusting the dry bulb setting. Once adjustment is made, monitor indoor conditions to verify the desired result.
- Units with "differential dry bulb and enthalpy" economizers are operated based on outdoor temperature and humidity. An enthalpy curve is used to control when conditions are acceptable for economizer use. Enthalpy curves provide a way to consider the amount of humidity it is acceptable to bring into the building based on outdoor temperature. To adjust the enthalpy curve in the JADE controller that will initiate economizer operation, navigate to the SETPOINTS menu using the UP/DOWN buttons. Next, navigate to the

ENTH CURVE menu using the UP/DOWN buttons. The default enthalpy curve is ES3. The range of this setting is ES1 to ES5. Bard recommends gradual adjustment of the enthalpy curve setting if adjustment is necessary. A higher enthalpy curve setting will result in greater energy savings, but will allow additional humidity into the indoor area. A lower enthalpy curve setting will result in lower humidity being allowed into the indoor area, but will result in less economizer operation. It is always important to consider the indoor requirements while maximizing economizer run time when adjusting the enthalpy curve setting. Once adjustment is made, monitor indoor conditions to verify the desired result. See **Enthalpy Settings** on page 11.

### **Minimum Position Setting**

Minimum position allows the user to program a blade setting that will allow a certain amount of outdoor air to enter the structure. Minimum blade ventilation occurs when the “A” terminal is energized on the IZ unit low voltage terminal strip. The blade setting is based on a voltage that is sent to the actuator motor.

### **2-Speed Fan Operation**

The JADE W7220 controller is programmed for 2-speed fan. This does not control fan speeds but allows for two minimum positions, one for OCC and Y1 inputs, (vent min low “low speed”) and one for Y2 input (vent min high “high speed”). This allows a minimum position blade setting for low speed and minimum position blade setting for high speed. See Figure 2 for more information on 2-speed fan settings.

To set MINIMUM POSITION airflow, select the correct unit model airflow graph from the graphs provided on pages 19 and 20. Go to MENU, then SETPOINTS; set MIN POS LOW control voltage using continuous fan CFM and MIN POS HIGH control voltage using the full load speed CFM. These settings will allow for consistent minimum airflow at low and high speed fan. See Figure 2 for additional 2-speed fan information.

The voltage range is 2-10VDC, where 2VDC is a minimum amount of outdoor air being brought into the building and 10VDC is the maximum amount. Charts are provided on pages 19 and 20 to indicate an airflow amount that will be brought into the building at the various voltage settings. Pressure relief to the occupied space is provided by a power exhaust fan located in the lower section of the unit (see **Economizer Exhaust** on page 7).

### **Low Outdoor Temperature Compressor Lockout**

The JADE controller has the ability to disable refrigerant compressor cooling at a certain outdoor temperature. The JADE will monitor the outdoor temperature measurement using the outdoor sensor. When the outdoor temperature reading is below the compressor lockout temperature, the JADE will not call for compressor cooling operation and only use the economizer. This applies if Y1 or Y2 is energized.

Refrigerant cooling with compressor use during extremely cold outdoor temperatures may shorten compressor life. To adjust the compressor lockout in the JADE controller that will disable compressor operation, navigate to the SETPOINTS menu using the UP/DOWN buttons. Next, navigate to the LOW T LOCK menu using the UP/DOWN buttons. The default minimum compressor lockout setting is 0°F (-17.7°C). The outdoor temperature range is -45°F (-42.7°C) to 80°F (26.6°C).

### **Mixed Air Temperature Setting**

As the economizer opens, indoor room air is mixed with the outdoor air entering the wall mount unit. The amount of indoor room air that is mixed with the outdoor air is dependent on the mixed air setpoint. During operation, the economizer will adjust the blade position to maintain a mixed air temperature. Bard has pre-programmed a mixed air temperature that allows for optimized cooling and energy savings while allowing for concurrent economizer and refrigerant compressor cooling. It is strongly recommended that for general use the mixed air temperature be kept at the default value. Adjustments may result in the indoor evaporator coil freezing or lower economizer cooling capacity. To adjust the mixed air setpoint in the JADE controller, navigate to the SETPOINTS menu using the UP/DOWN buttons. Next, navigate to the MAT SET menu using the UP/DOWN buttons. The default mixed air setting is 53°F (11.6°C). The mixed air temperature range is 38°F (3.3°C) to 65°F (18.3°C).

### **Operational Checkout (CHECKOUT Menu)**

It is always important to verify equipment functionality when using equipment to provide cooling to a space with equipment or occupants. A few simple steps will ensure that the economizer is functioning properly in the unit and will provide optimum performance. The following is provided as a basic checklist and additional steps may be required for advanced applications.

### **Checkout Procedure**

- Make sure the unit power is OFF. Visually inspect the economizer assembly including the seals around the damper blade, damper motor linkage and wire harnesses are snug that connect the JADE.
- Apply power to the unit. Wait a few minutes for the JADE to energize. Verify no alarms are present on the JADE display. Next, navigate to the CHECKOUT menu using the UP/DOWN buttons. Once in the checkout menu, select the following:
  - o DAMPER OPEN: This will force the economizer blade to open. Verify damper motor and linkage are functional.
  - o DAMPER CLOSE: This will force the economizer blade to close. Verify damper blade seals in the closed position.
  - o CONNECT Y1-O: This will force compressor cooling to operate. When energized, it may

take several minutes for the compressor to energize.

- o CONNECT Y2-O: This will force 2nd stage compressor cooling to operate. When energized, it may take several minutes for the compressor to energize.
- o CONNECT EXH1: This will force the exhaust fan to run.
- After completing checkout procedures, it is important that all panels are re-installed and secured before product use.

**NOTE: CHECKOUT** functions bypass the normal 5-minute delay for compressor protection. Be sure to allow for enough time to pass between tests so the compressor is not damaged from extreme short-cycling.

**FIGURE 2**  
**2-Speed Fan Operation**

The later versions of the JADE W7220 controller have the capability to work with a system using a 2-speed supply fan. The W7220 does not control the supply directly but uses the following input status to determine the speed of the supply fan and controls the OA damper to the required position.

State	Fan Speed
OCC	Low
Y1	Low
Y2	High
W	High

The W (heating mode) is not controlled by the W7220 but it requires the status to know where to position the OA damper for minimum position for fan speed.

The 2-speed fan delay is available when the system is programmed for 2-speed fan (in the System Setup menu item). The 2-speed fan delay is defaulted to 5 minutes and can be changed in the Advanced Setup menu item. When the unit has a call for Y1 In and in the free cooling mode and there is a call for Y2 In, the 2-speed fan delay starts and OA damper will modulate 100% open, the supply fan should be set to high speed by the unit controller. After the delay, one of the two following actions will happen:

- The Y2 In call will be satisfied with the damper 100% open and the fan on high speed and the call will turn off.
- OR
- If the call for additional cooling in the space has not been satisfied, the first stage of mechanical cooling will be enabled through Y1 Out or Y2 Out.

**Economizer Exhaust**

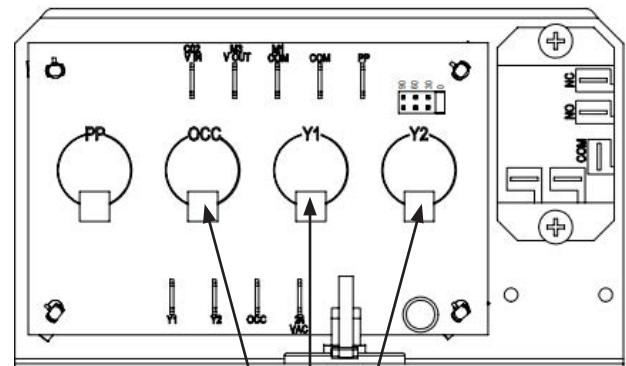
The variable speed exhaust fan is energized by the EXH1 terminal of the JADE W7220 when the outdoor air damper reaches 60% open. This setting opens the exhaust damper and turns the exhaust fan on and off. To change the setpoint, enter the SETTINGS menu and scroll to EXH1 H and EXH1 L (see **SETPOINTS** on page 9).

The exhaust fan speeds are controlled by three adjustable pots on the control board (see Figure 3). Each stage of ventilation has its own exhaust fan speed. The factory exhaust fan settings are set to maintain an acceptable room pressure at each comfort blower speed while maintaining low sound levels. Each individual installation could vary, and exhaust fan speeds may need adjusted if the factory settings are not maintaining an acceptable room pressure.

To field adjust the exhaust fan speeds, the outdoor conditions need to be suitable to economize and the economizer must be available and economizing. The thermostat will need to be set to OCC mode. Once the ACT POSITION reads 90% on the status screen, the OCC potentiometer on the board can be adjusted. Turn clockwise to increase or counterclockwise to decrease the exhaust fan speed (see Figure 3).

The Y1 and Y2 potentiometers can only be adjusted when the thermostat is calling for economizer and cooling and ACT POSITION reads 90%. On the W7220 display, scroll through the STATUS MENU. When the Y1 OUT is ON and the Y2 OUT is OFF, set the Y1 potentiometer to desired speed. When both Y1 OUT and Y2 OUT are ON, adjust the Y2 potentiometer. If no exhaust is needed, simply turn all three potentiometers counterclockwise until they stop. The PP potentiometer is not used.

**FIGURE 3**  
**Exhaust Fan Speed Control Board**



**Exhaust Fan Adjusting Pots**  
Clockwise to *increase* fan speed;  
counterclockwise to *decrease* fan speed.

## Exhaust Fan Off Delay Timer

There also is an exhaust fan off delay timer (see Figure 4). This timer is pre-set from the factory. This timer allows the exhaust fan to continue to run after the call for economizer is satisfied and allows the fresh air dampers time to close before the exhaust fan shuts off. If any adjustment is needed simply turn the red knob clockwise to increase the off-delay timing counterclockwise to decrease the off-delay timing.

**FIGURE 4**  
Exhaust Fan Off Delay Timer



## JADE Economizer Control Advanced Setup

### Review/Customize System Setup

Before being placed in service, the JADE economizer controller programming should be reviewed/customized through the following steps:

- 1. SYSTEM SETUP:** From the main screen, press the **SCROLL (UP/DOWN) BUTTONS** to navigate through the six (6) basic menu items to the **SYSTEM SETUP** menu.
  - Push the **SELECT (ENTER) BUTTON** to choose the **SYSTEM SETUP** menu.
  - Navigate through the multiple levels of **SYSTEM SETUP** by pushing the **SCROLL (UP/DOWN) BUTTONS**.
  - To change a specific parameter in the **SYSTEM SETUP** menu, press the **SELECT (ENTER) BUTTON** to display its current value. Press the **SCROLL (UP/DOWN) BUTTONS** to change or increase/decrease value. Press the **SELECT (ENTER) BUTTON** to save the new customized value—“CHANGE STORED” will be displayed. Press the **SELECT (ENTER) BUTTON** again to return to current menu parameter.
  - For specific **SYSTEM SETUP** level information, refer to **TABLE 1**.

**NOTE:** During an extended level of inactivity, the display of the JADE economizer controller will begin to automatically scroll through the various levels of the STATUS menu as a screensaver. Each level will stay for approximately 5 seconds before changing to the next level.

**TABLE 1**  
Bard System Setup (As Shipped)

Parameter	Value	Range	Notes
INSTALL	01/01/10		Display Order = MM/DD/YY Setting Order = DD/MM/YY
UNITS DEG	°F	°F/°C	Sets controller to read in either measurement
EQUIPMENT	HP OB	HP	Enables heat pump mode
AUX IN	HP (B)	HP (O) HP (B)	Energize heat pump on heat damper, closes to min position
FAN SPEED	2 Speed	1 Speed 2 Speed	Allows for two min position settings
FAN CFM	5000	100 to 15000	Not applicable
AUX1 OUT	SYS	NONE ERV EXH2 SYS	Product can be used to signal other devices, SYS used for alarm signal
OCC	INPUT	INPUT or ALWAYS	INPUT is for dedicated OCC signal, ALWAYS will be occupied signal all the time
FACTORY DEFAULT	NO	YES or NO	Resets to Honeywell factory defaults

**2. ADVANCED SETUP:** From the main screen, press the **SCROLL (UP/DOWN) BUTTONS** to navigate through the six (6) basic menu items to the **ADVANCED SETUP** menu.

- Push the **SELECT (ENTER) BUTTON** to choose the **ADVANCED SETUP** menu.
- Navigate through the multiple levels of **ADVANCED SETUP** by pushing the **SCROLL (UP/DOWN) BUTTONS**.
- To change a specific parameter in the **ADVANCED SETUP** menu, press the **SELECT (ENTER) BUTTON** to display its current value. Press the **SCROLL (UP/DOWN) BUTTONS** to change or increase/decrease value. Press the **SELECT (ENTER) BUTTON** to save the new customized value—“CHANGE STORED” will be displayed. Press the **SELECT (ENTER) BUTTON** again to return to current menu parameter.
- For specific **ADVANCED SETUP** level information, refer to **TABLE 2**.

**TABLE 2**  
**Bard Advanced Setup (As Shipped)**

Parameter	Value	Range	Notes
MAT LOW	45°F	35-65°F	Temp to activate freeze protection – Close Damper
FREEZE POS	CLOSE	CLO or MIN	Damper position upon freeze protection
CO <sub>2</sub> ZERO*	400 PPM	0 to 500 PPM	CO <sub>2</sub> PPM level to match CO <sub>2</sub> sensor start level
CO <sub>2</sub> SPAN*	1600 PPM	1000 to 3000 PPM	CO <sub>2</sub> PPM level to match CO <sub>2</sub> sensor start level
STG3 DLY	30 MIN	0 to 4.0h or OFF	Delay for 3rd Stage Cooling – allows for 3 stages of cooling, one stage for econ & two stages for compressor
SD DMPPR POS	CLOSE	CLO or OPN	Where damper goes upon shutdown signal
DCVCAL ENA	MAN	MAN AUTO	
MAT CAL	0°F	+/-2.5°F from actual reading	Mixed Air Sensor temperature calibration
OAS CAL	0		
OAS H CAL	0%	+/-10% from actual reading	Outdoor Air Humidity Sensor calibration for economizers using temp/humidity sensor
RA CAL	0		
DA CAL	0°F	+/-2.5°F	
25P FAN DLY	0 MIN	0 to 20 MIN	

\* CO<sub>2</sub> sensor connected

3. **SETPOINTS:** From the main screen, press the **SCROLL (UP/DOWN) BUTTONS** to navigate through the six (6) basic menu items to the **SETPOINTS** menu.

- Push the **SELECT (ENTER) BUTTON** to choose the **SETPOINTS** menu.
- Navigate through the multiple levels of **SETPOINTS** by pushing the **SCROLL (UP/DOWN) BUTTONS**.
- To change a specific parameter in the **SETPOINTS** menu, press the **SELECT (ENTER) BUTTON** to display its current value. Press the **SCROLL (UP/DOWN) BUTTONS** to change or increase/decrease value. Press the **SELECT (ENTER) BUTTON** to save the new customized value—“**CHANGE STORED**” will be displayed. Press the **SELECT (ENTER) BUTTON** again to return to current menu parameter.
- For specific **SETPOINTS** level information, refer to **TABLE 3**.

**TABLE 3**  
**Bard Setpoints (As Shipped)**

Parameter	Value	Range	Notes
MAT	53°F	38°F to 70°F	Mixed Air Temperature setpoint at which the economizer damper will begin to modulate to maintain setting
LOW T LOCK	32°F	-45°F to 80°F	Low outdoor ambient temperature for compressor lockout
DRYBLB SET	70°F	48°F to 80°F	Maximum outdoor temperature setting for “free” economizer cooling
DCV SET* (See <b>NOTE</b> under Table 6 on page 17)	1100	500 to 2000	Displays only if a CO <sub>2</sub> sensor is connected. Setpoint for Demand Control Ventilation of space. Above the setpoint, the OA dampers will modulate open to bring in additional OA to maintain a space ppm level below the setpoint.
MIN POS H	5V	2 to 10 VDC	Minimum Position for high speed fan
MIN POS L	6V	2 to 10 VDC	Minimum Position for low speed fan
VENTMIN*	3.2V	2 to 10 VDC	Displays only if a CO <sub>2</sub> sensor is connected.
VENTMAX*	2.8V	2 to 10 VDC	Displays only if a CO <sub>2</sub> sensor is connected.
ERV OAT SP	32°F	0 to 50°F	For ERV only
EXH1 L SET	60%	0 to 100%	Damper position when exhaust fan turns on for low speed fan
EXH1 H SET	60%	0 to 100%	Damper position when exhaust fan turns on for high speed fan
ENTH CURVE	ES3	ES1 to ES5	Enthalpy curve boundary

\* CO<sub>2</sub> sensor connected

**NOTE:** Economizer assembly should be ready to put into service. At any point during operation, in economizer mode or idle, real-time information from sensors and integral components can be accessed from the **STATUS** menu.

4. **STATUS:** From the main screen, press the **SCROLL (UP/DOWN) BUTTONS** to navigate through the six (6) basic menu items to the **STATUS** menu.

- Push the **SELECT (ENTER) BUTTON** to choose the **STATUS** menu.
- Navigate through the multiple levels of **STATUS** by pushing the **SCROLL (UP/DOWN) BUTTONS**.
- As the **STATUS** menu simply gives input/output information in real-time, there is no way to change or otherwise alter the displayed criteria. It is simply a window into the operation of the economizer controller.
- For specific **STATUS** level information, refer to **TABLE 4** on page 10.

**NOTE:** Upon power-up (or after power failure or low voltage condition), the controller will begin a 5-minute time delay before enabling mechanical cooling.

**TABLE 4**  
**Status Menu Levels**

Menu Level	Default Value	Notes
ECON AVAIL	YES/NO	Indicates if conditions are favorable for economizing
ECONOMIZING	YES/NO	Indicates if economizer is actively economizing
OCCUPIED	YES/NO	Indicates if dedicated 24V occupied signal is being received on terminal OCC
HEAT PUMP	COOL/HEAT	Displays actual compressor use if in HEAT PUMP mode
COOL Y1-IN	ON/OFF	Indicates if 24V signal is being received on terminal Y1-I
COOL Y1-OUT	ON/OFF	Displays if controller is actively calling for mechanical compressor cooling (24V on Y1-O)
COOL Y2-IN	ON/OFF	Indicates if 24V signal is being received on terminal Y2-I
COOL Y2-OUT	ON/OFF	Displays if controller is actively calling for Stg. 2 cooling (24V on Y2-O)
MA TEMP	0° to 140°F	Current mixed air temp
OA TEMP	-40° to 140°F	Current outdoor air temp
OA HUM	0% to 100%	Current outdoor air humidity for economizers using temp/humidity sensor
DAMPER OUT	2.0 to 10.0	Displays voltage to actuator
ACT POS	0 to 100%	Current % of opening
ACT COUNT	N/A	Current count of actuator cycles from installation
ACTUATOR OK	YES/NO	Indicates potential fault
EXH1 OUT	ON/OFF	Output of EXH1 Terminal
MECH COOL ON	0, 1, or 2	Stages of mechanical cooling currently active

**NOTE:** If there are any potential problems recognized by the economizer controller, it may be registered in the form of an alarm in the **ALARM(S)** menu. If there is a period of inactivity AND there is an alarm registering, the controller will randomly scroll through the **ALARM(S)** menu items as a screensaver.

**ALARM(S):** from the main screen, press the **SCROLL (UP/DOWN) BUTTONS** to navigate through the six (6) basic menu items to the **ALARM(S)** menu.

- Push the **SELECT (ENTER) BUTTON** to choose the **ALARM(S)** menu.
- Navigate through the current alarms in **ALARM(S)** by pushing the **SCROLL (UP/DOWN) BUTTONS**.

- Once the alarm has been identified, and the cause has been removed (e.g., replaced faulty sensor), the alarm may erase itself. If a manual alarm-erasing is required, it can be cleared from the display by navigating to the desired alarm and pressing the **SELECT (ENTER) BUTTON** to choose that specific alarm. “**ERASE?**” will display. Press the **SELECT (ENTER) BUTTON** again. “**ALARM ERASED**” will appear. Press the **MENU UP (EXIT) BUTTON** to complete the action and return to the previous menu.
- For specific **ALARM(S)** information, refer to **Table 5**.

**TABLE 5**  
**Alarm Examples**

Alarm(s)	Notes
MA T SENS ERR	Malfunctioning mixed air sensor
OA T SENS ERR	Malfunctioning outdoor air sensor
ACT STALLED	Actuator cannot reach desired percentage of opening
SYS ALARM	If AUX is set to SYS in SETPOINTS menu, SYS will display upon any registered alarm
NOTE: This is not a complete list of alarms. Additional alarms will display depending upon the parameter settings and configuration and attached equipment.	

**NOTE:** When using the Bard 8403-096 CO<sub>2</sub> controller, configure the sensor to 2-10VDC output (see CO<sub>2</sub> sensor instructions).

The JADE W7220 controller default setting is 1100 PPM. The economizer will modulate to maintain this CO<sub>2</sub> level in the room. The default setting can be changed in the SETPOINT menu in the DCV SET option when the CO<sub>2</sub> sensor is connected.

The CO<sub>2</sub> controller is active at any time the A terminal is energized.

The status of the CO<sub>2</sub> input can be viewed at any time in the STATUS menu.

#### **DVC with 2-Speed Fan**

Ventilation codes require that the same ventilation rates be provided regardless of supply fan speed. When the supply fan speed is reduced, the fresh air CFM also decreases.

If the same outside air damper position is retained, the airflow rate through the OA damper decreases below the preset levels. To restore ventilation rates to design levels, the damper positions VENTMIN and VENTMAX must be automatically adjusted when the fan speed changes. The JADE W7220 controller provides this function when it is configured for 2-speed fan operation through a second set of damper position setpoints.

During operation at high fan speed, the damper setpoint limits are designated VENTMIN H and VENTMAX H.

During operation at low fan speed, the damper setpoint limits change to VENTMIN L and VENTMIN H. These settings are higher than the comparable high speed settings and cause the outside air damper to open more to allow the same airflow rates to be admitted to the space.

Adjust the DCV setpoints VENTMAX H 9 volts and VENTMAX L 3.2 volts with supply fan speed in high speed and low speed respectively to provide the design load ventilation airflow rate by measuring outside air temperature, return air temperature and supply air temperature. Make damper position adjustments with at least 10°F temperature difference between the outdoor and return air temperatures.

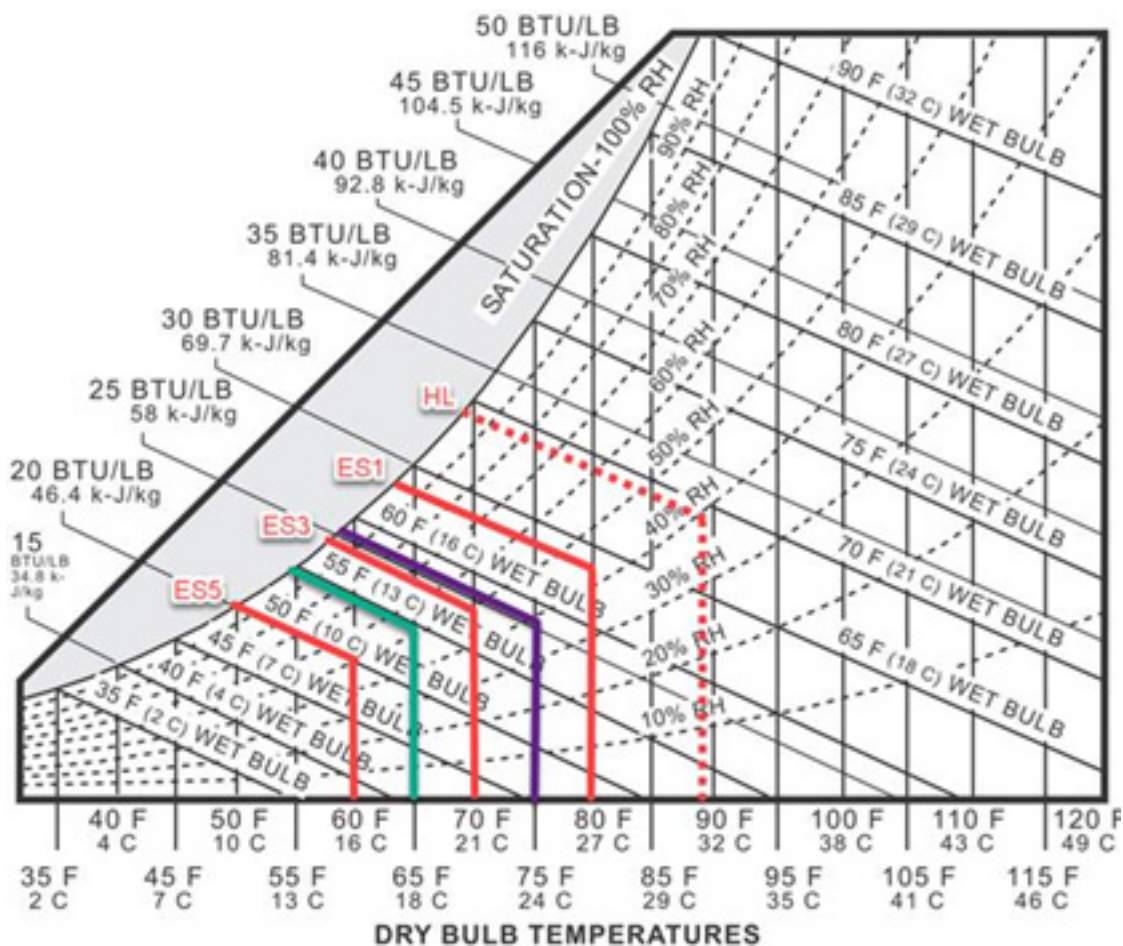
**NOTE:** When using the 8403-096 CO<sub>2</sub> sensor (or any 0-10 Vdc CO<sub>2</sub> sensor) with the JADE W7220 controller, set the CO2ZERO to 400 ppm and CO2SPAN to 1600 ppm in the ADVANCED SETUP menu.

### Enthalpy Settings

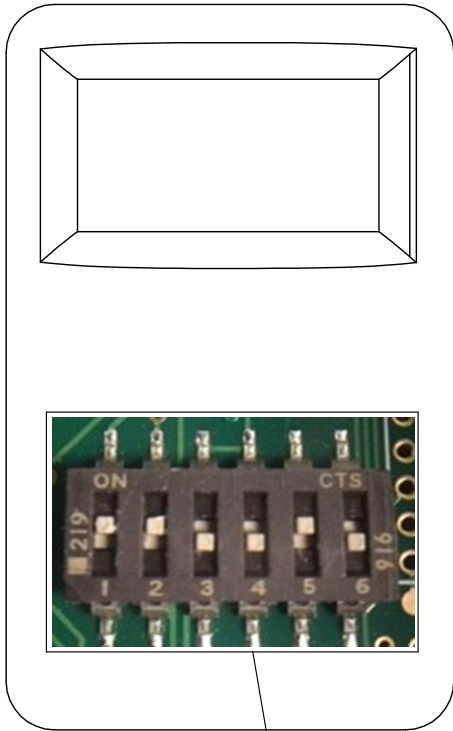
If economizer is enthalpy-based and was shipped with the temp/humidity sensor, the economizer must be programmed for the specific enthalpy curve boundary desired for “free” outdoor cooling (see Figure 5). The available enthalpy boundaries are all subject to specific OA temperature, OA humidity and OA dew points. If all of the OA conditions are below the specific points outlined in each boundary, the conditions are good to economize and economizer mode is set to “YES”. If some or all the OA conditions are above the specific points outlined in each boundary, the conditions are not good to economize and the economizer mode is set to “NO”.

ES3 is factory default.

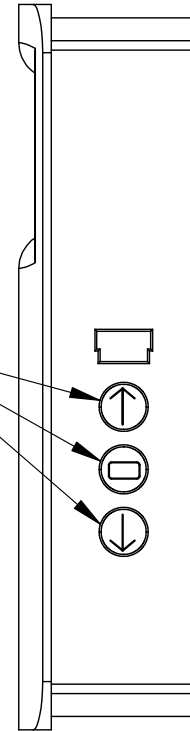
**FIGURE 5**  
Enthalpy Curve Settings



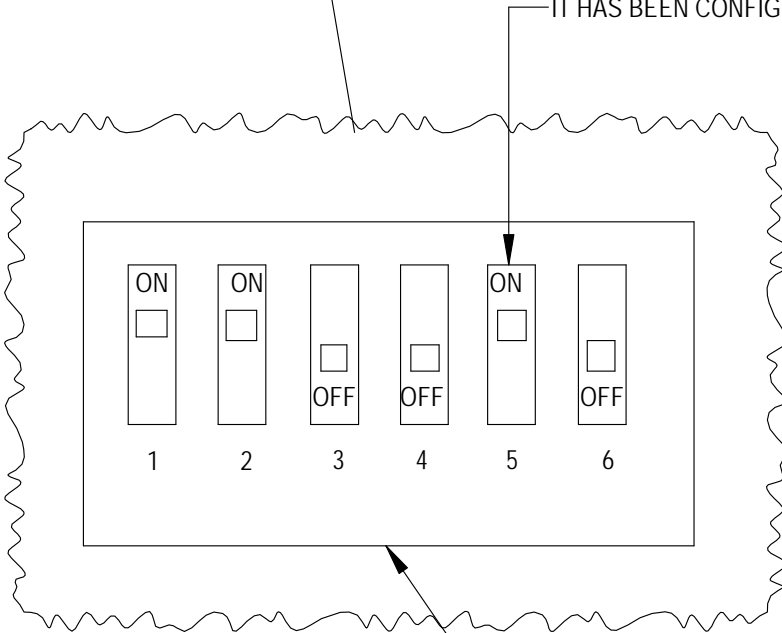
**FIGURE 6**  
**CO<sub>2</sub> Sensor Default and Final Settings**  
**Bard P/N 8403-096 CO<sub>2</sub> Controller**



PRESS UP AND DOWN ARROWS TO ENTER CONFIGURATION MODE USE ARROWS TO SELECT SETTING. PUSH MIDDLE BUTTON TO CHANGE. CONTROLLER WILL SHOW SET.



NOTE: MENU DIP SWITCH MUST BE IN "ON" POSITION #5 TO CHANGE ANY SETTINGS WITH THE SIDE BUTTONS. TO LOCK THE CO<sub>2</sub> CONTROLLER MOVE DIP SWITCH TO "OFF" AFTER IT HAS BEEN CONFIGURED.



DIP SWITCHES MUST BE POSITIONED AS SHOWN FOR PROPER OPERATION

Settings	Recommended	Default
RON	Not Used	
ROF	Not Used	
DSP	C	CT
UNI	US	US
COL	700	0
COH	1500	2000
TOL	Not Used	
TOH	Not Used	
BAR	See Instruction with Controller For High Altitude Installations	
CAL	Used for Field Calibration	

MIS-4025 A

## Economizer Sequence of Operation

### Condition – Cool/Dry OA Conditions

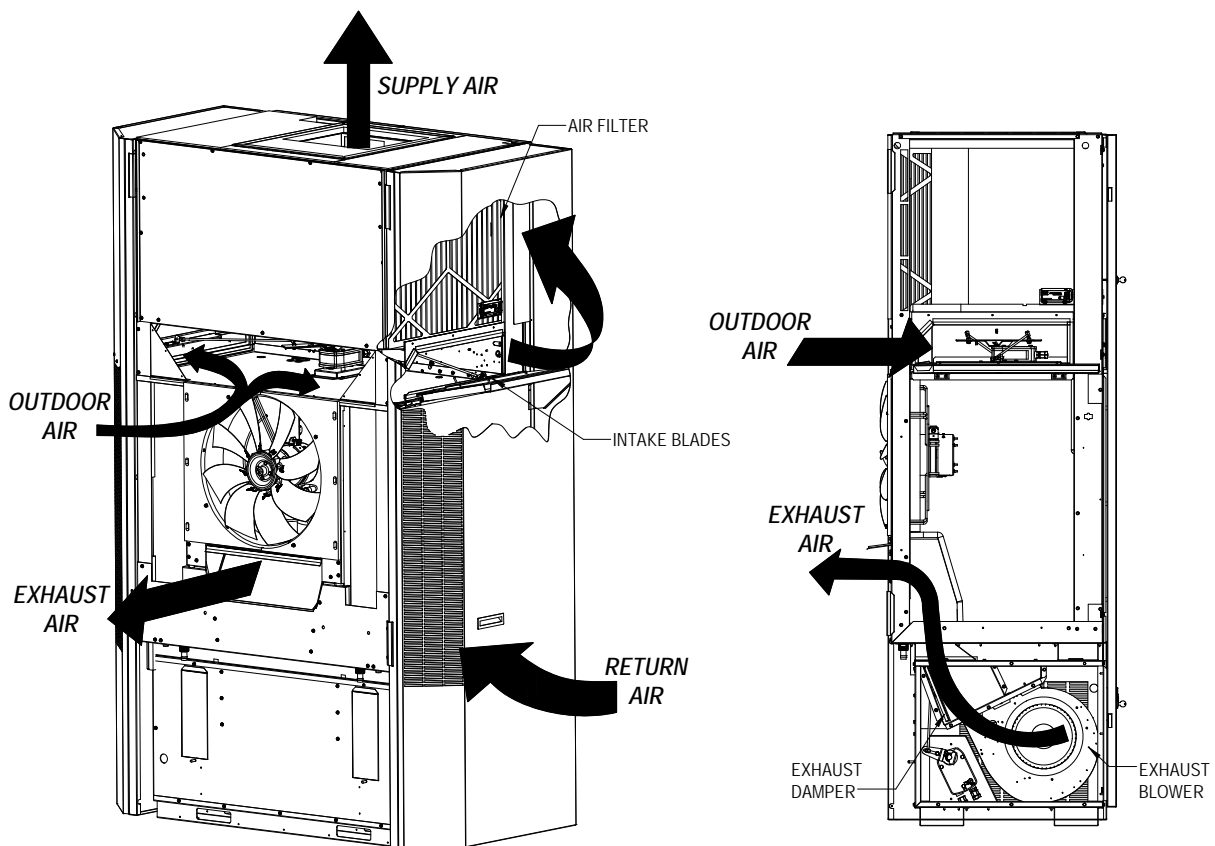
- 1<sup>st</sup> Stage Cooling closes and sends signal to JADE control. Since the air temperature outside is cooler than the preset **DRYBULB SET** setting, or is below the **ENTH CURVE** boundary in the **SETPOINTS** menu, the actuator will power the economizer damper to “economizer” mode as the indoor blower motor starts. The mixed air sensor senses a mixture of return air and cool outdoor air and modulates opening to achieve preset **MAT SET** setting in **SETPOINTS** menu. Compressor operation is inhibited.
- 2<sup>nd</sup> Stage Cooling closes and sends a signal to JADE control, which closes the Y1-O relay to begin mechanical cooling. **The economizer damper REMAINS OPEN in tandem operation with the compressor** as long as the OA conditions do not rise above the preset **DRYBULB SET/ENTH CURVE** settings in the **SETPOINTS** menu.
- 3<sup>rd</sup> Stage Cooling (if available) closes and sends a signal to JADE control, which closes the Y2-O relay to begin 2<sup>nd</sup> stage mechanical cooling. **The**

economizer damper **REMAINS OPEN** in tandem operation with the compressor as long as the temperature outside does not rise above the preset **DRYBULB SET** setting in the **SETPOINTS** menu).

### Condition – Warm/Humid OA Conditions

- 1<sup>st</sup> Stage Cooling closes and sends signal to JADE control. Since the OA conditions are above the preset **DRYBULB SET/ENTH CURVE** setting in the **SETPOINTS** menu, the control will simply close the Y1-O relay to initiate mechanical cooling. **The economizer damper will remain closed or in a minimum ventilation setting depending upon occupied status.**
- 2<sup>nd</sup> Stage Cooling (if available) closes and sends a signal to JADE control. Since the OA conditions are still above than the preset **DRYBULB SET/ENTH CURVE** setting in the **SETPOINTS** menu, the control will simply close the Y2-O relay to initiate 2<sup>nd</sup> stage mechanical cooling. **The economizer damper will remain closed or in a minimum ventilation setting depending upon occupied status.**

FIGURE 7  
Vent Airflow Path



MIS-4409

## Service

**IMPORTANT:** Turn power off before performing any service to the unit.

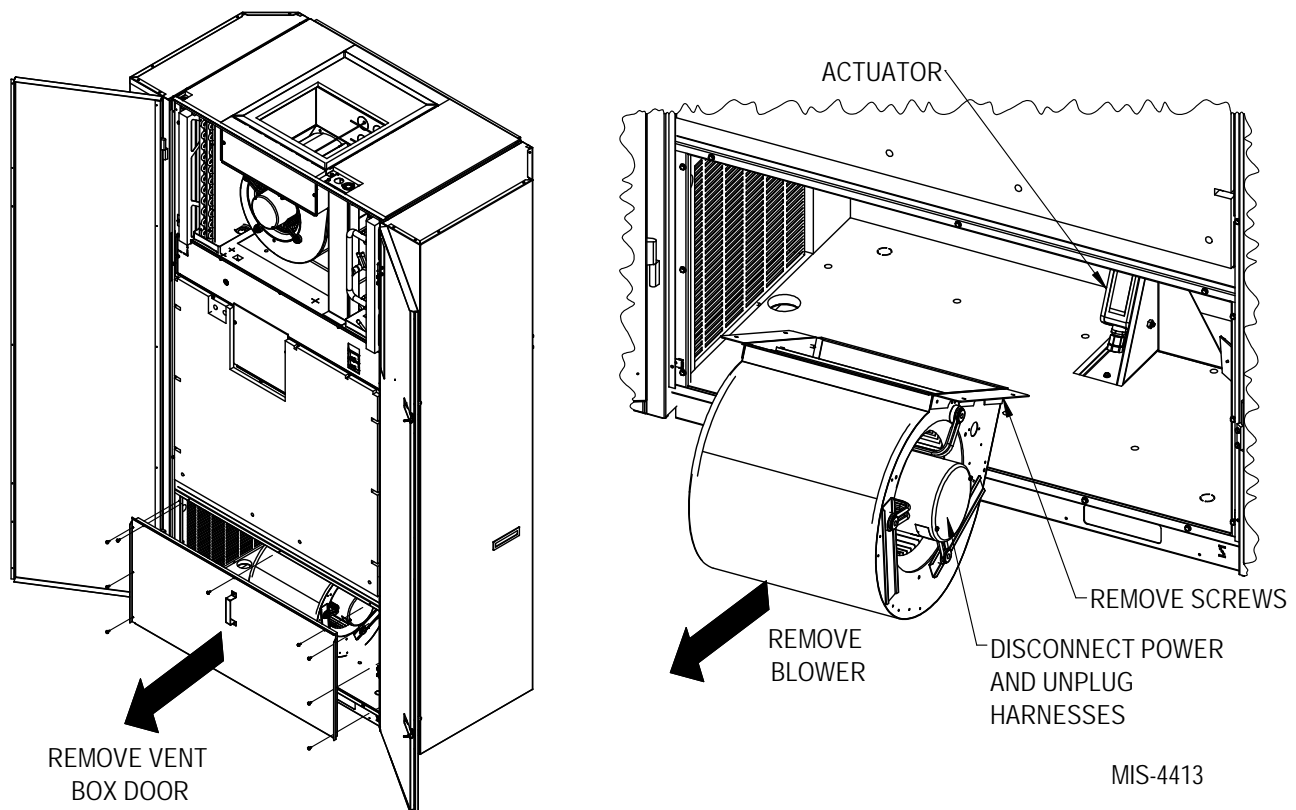
### Exhaust Damper and Actuator

The exhaust damper and actuator are located in the lower section of the unit in the vent box (see Figure 8). To access the actuator, the vent box door must be removed. The blower assembly can then be unplugged and removed to access the actuator.

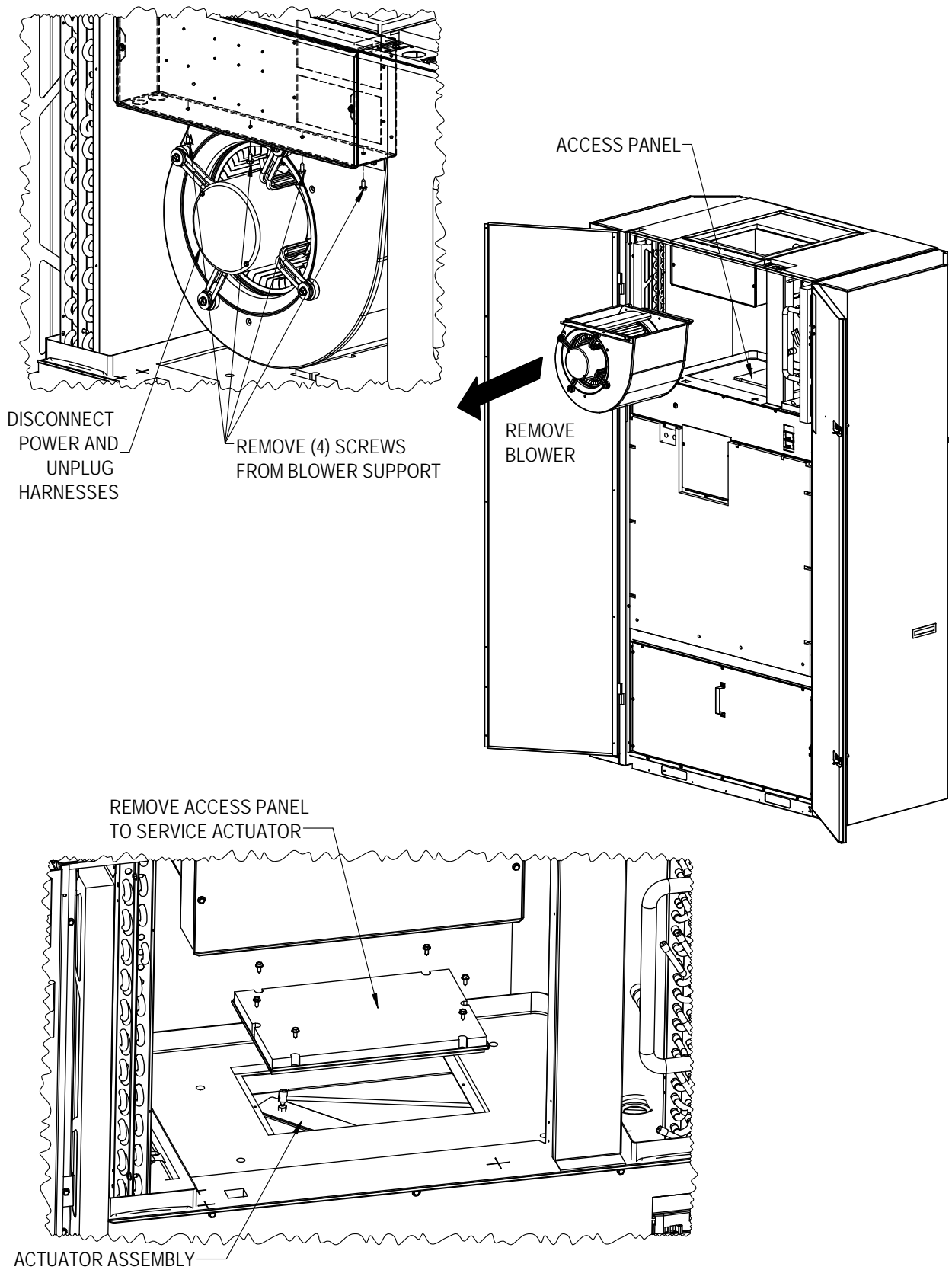
### Intake Actuator

The intake section of the vent is located behind the control panel (see Figure 9). If the unit is installed against the wall, the intake actuator can be accessed through a panel in the evaporator section of the unit. Unplug and remove the unit blower from the unit. This will provide access to the panel on the evaporator partition. Remove the panel to service the actuator.

**FIGURE 8**  
**Exhaust Damper Actuator Access**

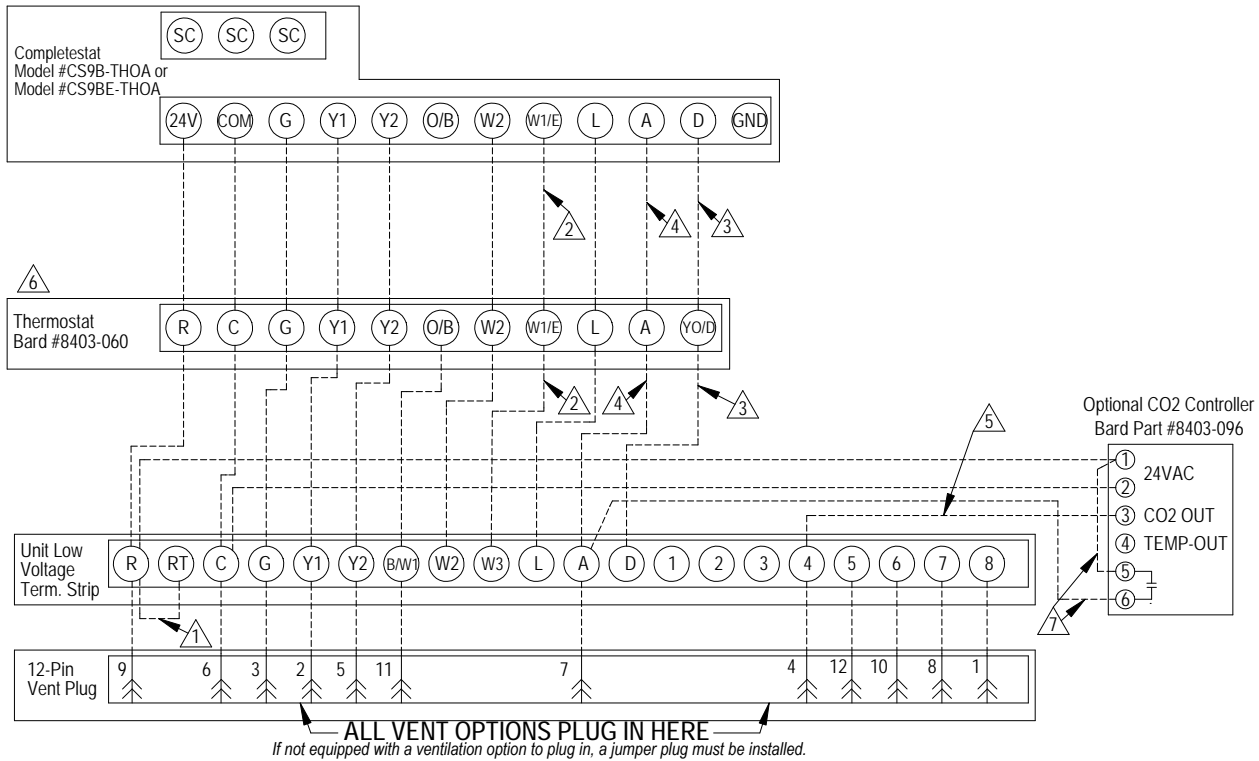


**FIGURE 9**  
**Intake Damper Actuator Access**



MIS-4412

**FIGURE 10**  
**Programmable Thermostat Connections for ECON-\*\*5 with 2-Stage Heat Pumps**



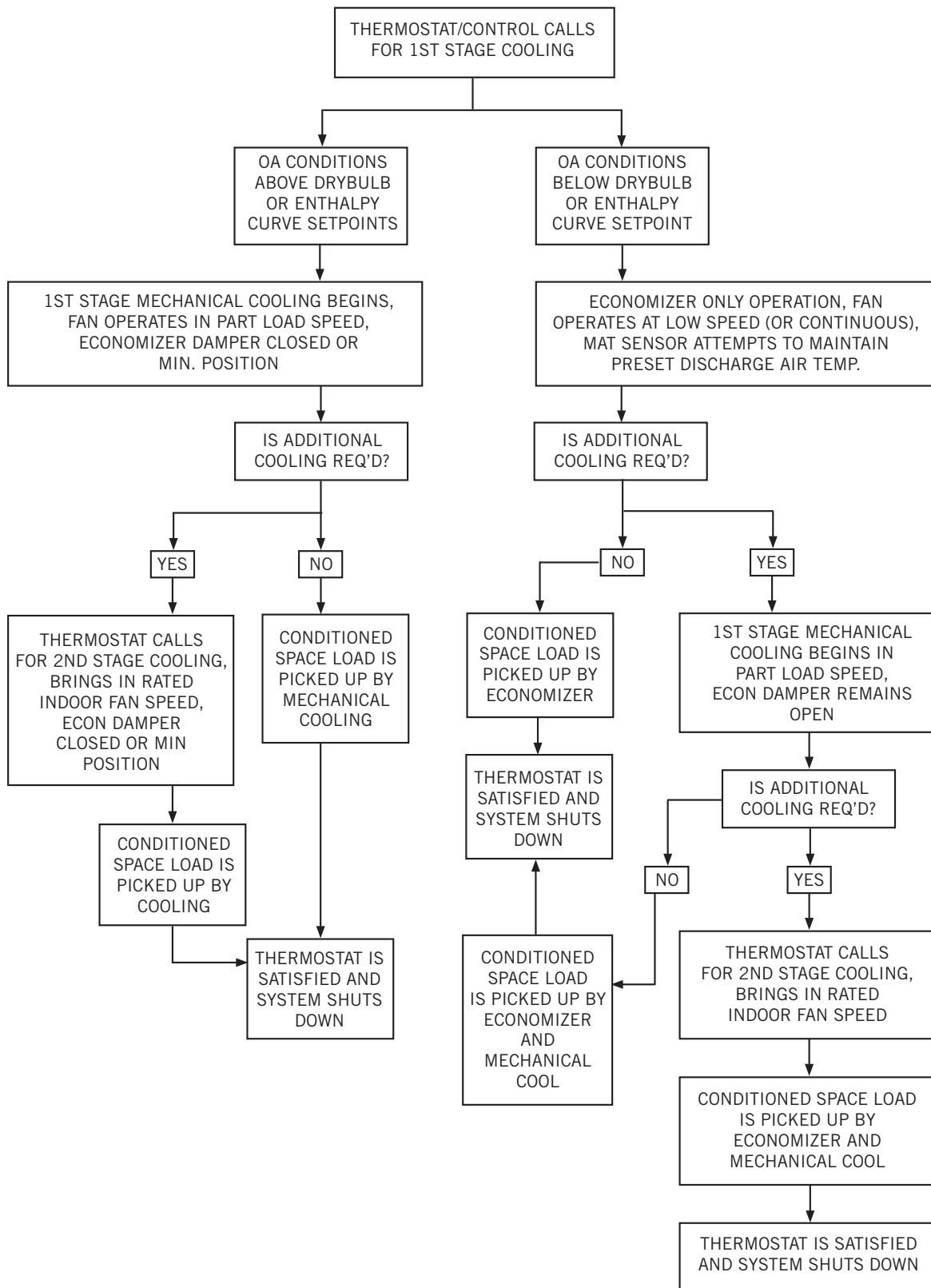
- ① Factory installed jumper. Remove jumper and connect to N.C fire alarm circuit if emergency shutdown required.
- ② Wire not needed below 15KW.
- ③ Wire required for dehumidification models only.
- ④ Do not connect "A" from thermostat if optional CO2 controller is used
- ⑤ 0-10 VDC modulating CO2 control signal for modulating ventilation control (optional for ECON only - see vent instruction manuals)
- ⑥ Ensure model configuration is heat pump and not heat/cool. Must be configured to programmable and fan set to be programmed fan for the "A" output to function during scheduled occupied periods. Must be configured for multi-stage for Y1 output to be active 1st stage cooling. For dehumidification, must be configured for "No Economizer" for YO/D to be active for humidity control.
- ⑦ Do not add these wires if setting up for modulating control.

MIS-4395

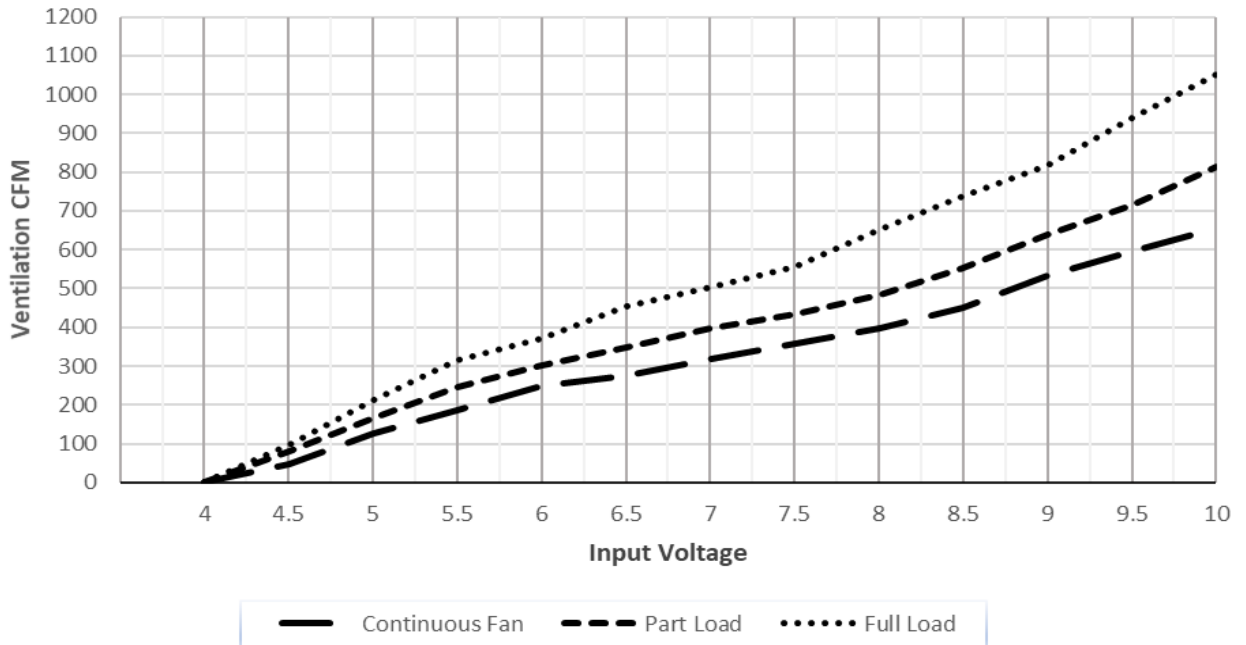
**TABLE 6**  
**Unit Operation with Economizer Options**

Unit Operation	Occ. Signal	Econ Available	Low Voltage 24VAC							Fan Speed	Dampers
			G	Y1	Y2	W1	W2	W3	A		
Blower Only	Yes	No	X						X	Vent	Min. Pos. Low
Blower Only	Yes	Yes	X						X	Vent	Min. Pos. Low
Blower Only	No	No	X							Vent	Closed
Part Load Cool	Yes	No	X	X					X	Part Load	Min. Pos. Low
Part Load Cool	Yes	Yes	X	X					X	Part Load	Open*
Part Load Cool	No	No	X	X						Part Load	Closed
Part Load Cool	No	Yes	X	X						Part Load	Open*
Full Load Cool	Yes	No	X	X	X				X	Full Load	Min. Pos. High
Full Load Cool	Yes	Yes	X	X	X				X	Full Load	Open*
Full Load Cool	No	No	X	X	X					Full Load	Closed
Full Load Cool	No	Yes	X	X	X					Full Load	Open*
1st Stage Heat	Yes	No	X	X		X			X	Part Load	Min. Pos. Low
1st Stage Heat	No	No	X	X		X				Part Load	Closed
2nd Stage Heat	Yes	No	X	X	X	X			X	Full Load	Min. Pos. High
2nd Stage Heat	No	No	X	X	X	X				Full Load	Closed
2nd Stage Heat and EH	Yes	No	X	X	X	X	X		X	Full Load	Min. Pos. High
2nd Stage Heat and EH	No	No	X	X	X	X	X			Full Load	Closed
Emergency EH	Yes	No	X				X	X	X	Full Load	Min. Pos. Low
Emergency EH	No	No	X				X	X		Full Load	Closed

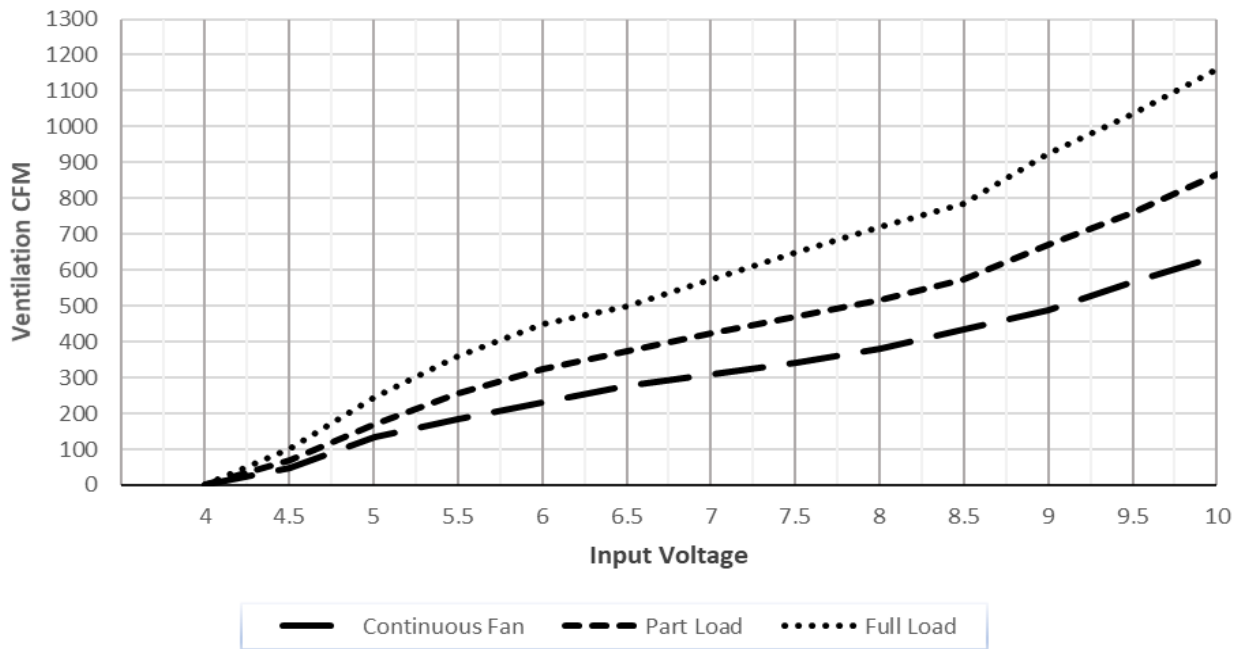
## 2-Stage Compressor Units – Economizer Operation – Part and Full Load Operation



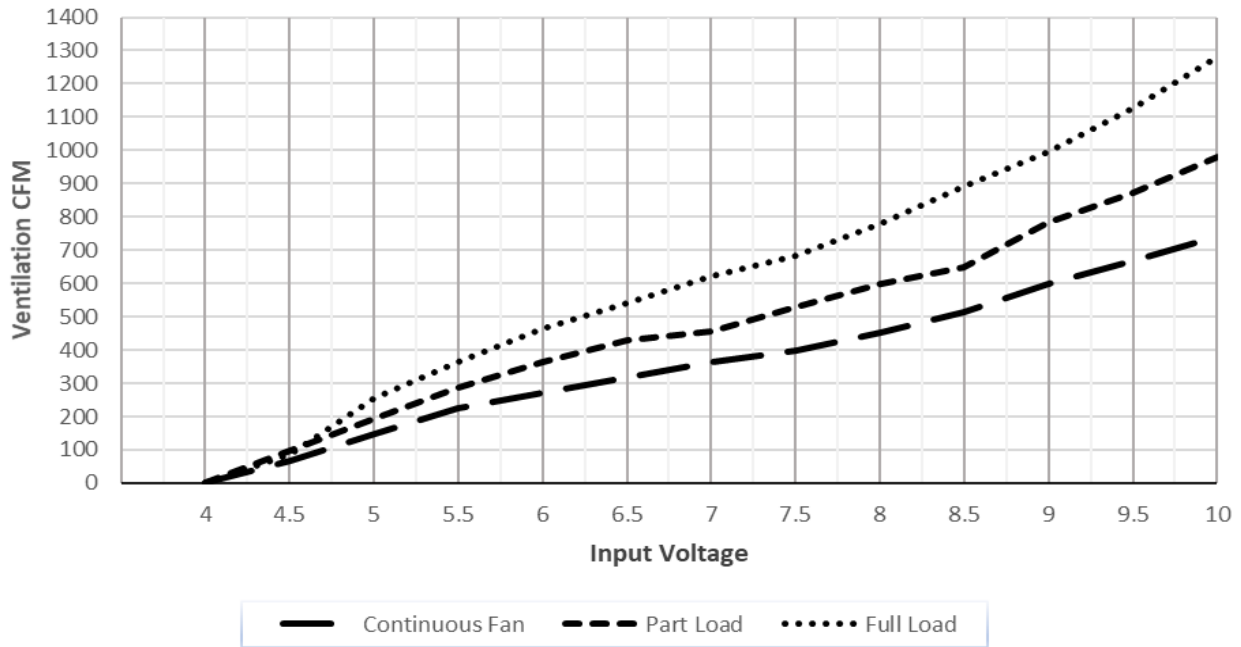
**GRAPH 1**  
I36Z2 Ventilation Delivery



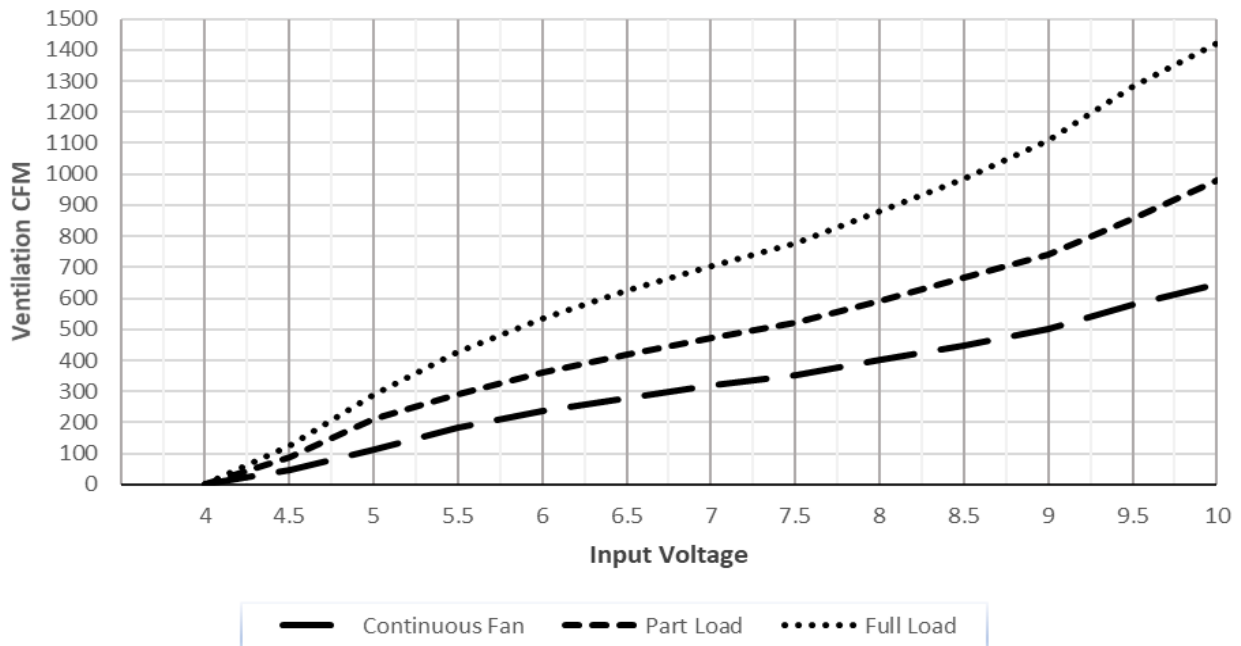
**GRAPH 2**  
I42Z2 Ventilation Delivery



**GRAPH 3**  
**I48Z2 Ventilation Delivery**



**GRAPH 4**  
**I60Z2 Ventilation Delivery**



## Default Tables

**TABLE 7A**  
**Menu Structure ①**

Menu	Parameter	Parameter Default Value	Parameter Range and Increment ②	Notes
STATUS	ECON AVAIL	NO	YES/NO	YES = economizing available; the system can use outdoor air for free cooling when required.
	ECONOMIZING	NO	YES/NO	YES = Outdoor air being used for 1st stage cooling.
	OCCUPIED	NO	YES/NO	YES = OCC signal received from space thermostat or unitary controller. YES = 24 Vac on terminal OCC No = 0 Vac on terminal OCC.
	HEAT PUMP	N/A	COOL HEAT	Displays COOL or HEAT when system is set to heat pump (non-conventional).
	COOL Y1-IN	OFF	ON/OFF	Y1-I signal from space thermostat or unitary controller for cooling stage 1. ON = 24 Vac on term Y1-I; OFF = 0 Vac on term Y1-I
	COOL Y1-OUT	OFF	ON/OFF	Cool Stage 1 Relay Output to mechanical cooling (Y1-OUT terminal).
	COOL Y2-IN	OFF	ON/OFF	Y2-I signal from space thermostat or unitary controller for second stage cooling. ON = 24 Vac on term Y2-I; OFF = 0 Vac on term Y2-I
	COOL Y2-OUT	OFF	ON/OFF	Cool Stage 2 Relay Output to mechanical cooling (Y2-OUT terminal).
	MA TEMP	--. °F	-40 to 150 °F	Displays value of measured mixed air from MAT sensor. Displays --.°F if not connected, short or out-of-range.
	DA TEMP	--. °F	-40 to 150 °F	Displays when Discharge Air Sylk Bus sensor is connected and displays measured discharge air temperature. Displays --.°F if sensor sends invalid value, if not connected, short or out-of-range.
	OA TEMP	--. °F	-40 to 140 °F	Displays measured value of outdoor air temperature. Displays --.°F if sensor sends invalid value, if not connected, short or out-of-range.
	OA HUM	-- %	0 to 100%	Displays measured value of outdoor humidity from OA Sylkbus sensor. Displays --% if not connected, short or out-of-range.
	RA TEMP	--. °F	0 to 140 °F	Displays measured value of return air temperature from RA Sylkbus sensor. Displays --.°F if sensor sends invalid value, if not connected, short or out-of-range.
	RA HUM	-- %	0 to 100%	Displays measured value of return air humidity from RA Sylkbus sensor. Displays --% if sensor sends invalid value, if not connected, short or out-of-range.
	IN CO2	--- ppm	"0 to 2000 ppm"	Displays value of measured CO <sub>2</sub> from CO <sub>2</sub> sensor. Invalid if not connected, short or out-of-range. May be adjusted in Advanced menu by Zero offset and Span.
	DCV STATUS	N/A	ON/OFF	Displays ON if above setpoint and OFF if below setpoint, and ONLY if a CO <sub>2</sub> sensor is connected.
	DAMPER OUT	2.0V	2.0 to 10.0 V	Displays output voltage or position to the damper actuator. ③
	ACT POS	N/A	0 to 100%	Displays actual position of actuator.
	ACT COUNT	N/A	1 to 65,535	Displays number of times actuator has cycled. 1 cycle equals the sum of 180° of movement in any direction.

N/A = Not Applicable

① Table 7 illustrates the complete hierarchy. Actual menu parameters may be different depending on the configuration. For example, if there is no DCV (CO<sub>2</sub>) sensor, then none of the DCV parameters appear.

② When values are displayed, pressing and holding the ▲ or ▼ button causes the display to automatically increment.

③ When used with Honeywell communicating actuator, the damper out is reported in XX.X% open versus XX.X Vdc.

**TABLE 7B**  
**Menu Structure ① (cont.)**

Menu	Parameter	Parameter Default Value	Parameter Range and Increment ②	Notes
STATUS (cont.)	ACTUATOR	N/A	OK/Alarm (on Alarm menu)	Displays Error if voltage or torque is below actuator range.
	EXH1 OUT	OFF	ON/OFF	Output of EXH1 terminal. Displays ON when damper position reaches programmed percentage setpoint. ON = 24 Vac Output; OFF = No Output.
	EXH2 OUT	OFF	ON/OFF	Output of AUX1 O terminal. Displays ON when damper position reaches programmed percentage setpoint. ON = 24 Vac Output; OFF = No Output. Displays only if AUX1 O = EXH2
	ERV	OFF	ON/OFF	Output of AUX1 O terminal. ON = 24 Vac Output; OFF = No Output. Displays only if AUX1 O = ERV
	MECH COOL ON or HEAT STAGES ON	0	0, 1 or 2	Displays number of mechanical cooling stages that are active. Displays the stage of heat pump heating that is active.
	FAN SPEED	N/A	LOW or HIGH	Displays speed of fan on a 2-speed fan unit.
	W (HEAT IN)	N/A	ON/OFF	Displays status of heat on a 2-speed fan unit.
SETPOINTS	MAT SET	53°F	38 to 70 °F; increment by 1	The economizer will modulate the OA damper to maintain the mixed air temperature at the setpoint.
	LOW T LOCK	32°F	-45 to 80 °F increment by 1	Setpoint determines outdoor temperature when the mechanical cooling cannot be turned on. Commonly referred to as the compressor lockout. At or below the setpoint, the Y1-O and Y2-O will not be energized on the controller.
	DRYBLB SET	63°F	-45 to 80 °F increment by 1	<i>Dry bulb setpoint will only appear if using dry bulb change over.</i> Setpoint determines where the economizer will assume outdoor air temperature is good for free cooling; e.g., at 63 °F setpoint unit will economize at 62 °F and below and not economize at 64 °F and above. There is a 2 °F deadband.
	DRYBLB DIF Available firmware 1.15, June 2018, and later.	0°F	0 to 6°F; increment by 2	Drybulb differential will only show if using dual drybulb, i.e., when an outdoor air temperature sensor C7250 is attached to OAT terminals and a C7400S sensor is wired to S-Bus and configured for RAT (return air). Free cooling will be assumed whenever OA Temp is below <i>RAT minus this drybulb differential setting.</i>
	ENTH CURVE	ES3	ES1, ES2, ES3, ES4 or ES5	<i>ES curve will only appear if using enthalpy changeover.</i> Enthalpy boundary "curves" for economizing using single enthalpy. See page 11 for description of enthalpy curves.
	DCV SET	1100ppm	500 to 2000 ppm; increment by 100	Displays ONLY if a CO <sub>2</sub> sensor is connected. Setpoint for Demand Control Ventilation of space. Above the setpoint, the OA dampers will modulate open to bring in additional OA to maintain a space ppm level below the setpoint.
	MIN POS	2.8 V	2 to 10	Displays ONLY if a CO <sub>2</sub> sensor is NOT connected. With 2-speed fan units, MIN POS L (low speed fan) and MIN POS H (high speed fan) settings are required. Default for MIN POS L is 3.2V and MIN POS H is 2.8V.

N/A = Not Applicable

- ① Table 7 illustrates the complete hierarchy. Actual menu parameters may be different depending on the configuration. For example, if there is no DCV (CO<sub>2</sub>) sensor, then none of the DCV parameters appear.
- ② When values are displayed, pressing and holding the ▲ or ▼ button causes the display to automatically increment.

**TABLE 7C**  
**Menu Structure ① (continued)**

Menu	Parameter	Parameter Default Value	Parameter Range and Increment ②	Notes
SETPOINTS (cont.)	VENTMAX	2.8 V	2 to 10 Vdc	Displays only if a CO <sub>2</sub> sensor is connected. Used for Vbz (ventilation max cfm) setpoint. VENTMAX is the same setting as MIN POS would be if there is no CO <sub>2</sub> sensor.
			100 to 9990 cfm; increment by 10	If OA, MA RA and CO <sub>2</sub> sensors are connected and DCV CAL ENABLE is set to AUTO mode, the OA dampers are controlled by CFM and displays from 100 to 9990 cfm.
			2 to 10 Vdc	With 2-speed fan units, VENTMAX L (low speed fan) and VENTMAX H (high speed fan) settings are required. Default for VENTMAX L is 3.2V and VENTMAX H is 2.8V.
	VENTMIN	2.25 V	2 to 10 Vdc	Displays only if CO <sub>2</sub> sensor is connected. Used for Va (ventilation min cfm) setpoint. This is the ventilation requirement for less than maximum occupancy of the space.
			100 to 9990 cfm; increment by 10	If OA, MA RA and CO <sub>2</sub> sensors are connected and DCV CAL ENABLE is set to AUTO mode, the OA dampers are controlled by CFM and displays from 100 to 9990 cfm.
			2 to 10 Vdc	With 2-speed fan units, VENTMIN L (low speed fan) and VENTMIN H (high speed fan) settings are required. Default for VENTMIN L is 2.5V and VENTMIN H is 2.25V.
	ERV OAT SP ③	32°F	0 to 50 °F; increment by 1	Only when AUX1 0 = ERV
EXH1 SET	50%	0 to 100%; increment by 1	Setpoint for OA damper position when exhaust fan 1 is powered by the economizer. With 2-speed fan units, Exh1 L (low speed fan) and Exh1 H (high speed fan) settings are required. Default for Exh1 L is 65% and Exh1 H is 50%.	
EXH2 SET	75%	0 to 100%; increment by 1	Setpoint for OA damper position when exhaust fan 2 is powered by the economizer. Only used when AUX1 0 is set to EHX2. With 2-speed fan units, Exh2 L (low speed fan) and Exh2 H (high speed fan) settings are required. Default for Exh2 L is 80% and Exh2 H is 75%.	
SYSTEM SETUP	INSTALL	01/01/11		Display order = MM/DD/YY Setting order = DD, MM, then YY.
	UNITS DEG	°F	°F or °C	Sets economizer controller in degrees Fahrenheit or Celsius.
	EQUIPMENT	CONV	CONV HP	CONV = conventional. HP O/B = Enables Heat Pump mode. Use AUX2 I for heat pump input from thermostat or controller.
	AUX2 IN	Heat (W1) ④ <b>NOTE:</b> If field factory default is available, AUX2 IN will default back to Shutdown (SD).	0 to 6°F; increment by 2	In CONV mode: SD = Enables configuration of shutdown (default) W = Informs controller that system is in heating mode <b>NOTE:</b> If using 2-speed fan mode, CONV mode must be programmed for W. Shutdown is not available in the two-speed fan mode. In HP O/B mode: HP(O) = energize heat pump on Cool (default) HP(B) = energize heat pump on Heat

- ① Table 7 illustrates the complete hierarchy. Actual menu parameters may be different depending on the configuration. For example, if there is no DCV (CO<sub>2</sub>) sensor, then none of the DCV parameters appear.
- ② When values are displayed, pressing and holding the ▲ or ▼ button causes the display to automatically increment.
- ③ ERV Operation: When in cooling mode AND the conditions are NOT OK for economizing, the ERV terminal will be energized. In the heating mode, the ERV terminal will be energized when the OA is below the ERV OAT setpoint in the setpoint menu.
- ④ Default for AUX2 IN changed from SD to W1 with 1.15 firmware (June 2018).

**TABLE 7D**  
**Menu Structure ① (cont.)**

Menu	Parameter	Parameter Default Value	Parameter Range and Increment ②	Notes
SYSTEM SETUP (cont.)	FAN SPEED	2 speed ③ <i>NOTE: If field factory default is available, FAN SPEED will default back to 1 speed.</i>	1 speed/ 2 speed	Sets economizer controller for operation of 1 speed or 2 speed supply fan. The controller does not control the fan but positions the OA and RA dampers to the heating or cooling mode. See Figure 2 on page 7 for modes and position. <i>NOTE: 2-speed fan option also needs Heat (W1) programmed in AUX 2 In.</i>
	FAN CFM	5000 cfm	100 to 50000 cfm; increment by 100	This is the capacity of the RTU. The value is found on the label from the RTU manufacturer. The cfm of the fan is only used with DCV CAL ENABLE AUO.
	AUX1 OUT	NONE	NONE ERV EXH2 SYS	<ul style="list-style-type: none"> <li>• NONE = not configured (output is not used)</li> <li>• ERV = Energy Recovery Ventilator ④</li> <li>• EXH2 = second damper position 24 Vac out for second exhaust fan</li> <li>• SYS = use output as an alarm signal</li> </ul>
	OCC	INPUT	INPUT or ALWAYS	When using a setback thermostat with occupancy out (24 Vac), the 24 Vac is input "INPUT" to the OCC terminal. If no occupancy output from the thermostat then change program to "ALWAYS" OR add a jumper from terminal R to OCC terminal.
	FACTORY DEFAULT	NO	NO or YES	Resets all set points to factory defaults when set to YES. LCD will briefly flash YES and change to NO but all parameters will change to factory default values.
ADVANCED SETUP	MA LO SET	45 °F	35 to 65 °F; increment by 1	Temp to activate freeze protection (close damper or modulate to MIN POS if temp falls below set value).
	FREEZE POS	CLO	CLO MIN	Damper position when freeze protection is active (closed or MIN POS).
	CO2 ZERO	0 ppm	0 to 500 ppm; increment by 10	CO <sub>2</sub> ppm level to match CO <sub>2</sub> sensor start level.
	CO2 SPAN	2000 ppm	1000 to 3000 ppm; increment by 50	CO <sub>2</sub> ppm span to match CO <sub>2</sub> sensor; e.g.; 500-1500 sensor output would be 500 CO <sub>2</sub> zero and 1000 CO <sub>2</sub> span.
	STG3 DLY	2.0h	0 min, 5 min, 15 min, then 15 min intervals. Up to 4h or OFF.	Delay after stage 2 for cool has been active. Turns on 2nd stage of mechanical cooling when economizer is 1st stage call and mechanical cooling is 2nd stage call. Allows three stages of cooling: 1 economizer and 2 mechanical. OFF = no Stage 3 cooling.
	SD DMPR POS	CLO	CLO OPN	Indicates shutdown signal from space thermostat or unitary controller. When controller receives 24 Vac input on the SD terminal in conventional mode, the OA damper will open if programmed for OPN and OA damper will close if programmed for CLO. All other controls, e.g., Y1-O, Y2-O, EXH1, etc. will shut off.
	DA LO ALM	45 °F	NONE 35 °F to 65 °F in 5 °F increments	Used for alarm for when the DA air temperature is too low. Set lower range of alarm, below this temperature the alarm will show on the display.

① Table 7 illustrates the complete hierarchy. Actual menu parameters may be different depending on the configuration. For example, if there is no DCV (CO<sub>2</sub>) sensor, then none of the DCV parameters appear.

② When values are displayed, pressing and holding the ▲ or ▼ button causes the display to automatically increment.

③ Default for FAN SPEED changed from 1-speed to 2-speed with 1.15 firmware (June 2018).

④ ERV Operation: When in cooling mode AND the conditions are NOT OK for economizing, the ERV terminal will be energized. In the heating mode, the ERV terminal will be energized when the OA is below the ERV OAT setpoint in the setpoint menu.

**TABLE 7E**  
**Menu Structure ① (cont.)**

Menu	Parameter	Parameter Default Value	Parameter Range and Increment ②	Notes
ADVANCED SETUP (cont.)	DA HI ALM	80 °F	NONE 70 °F to 180 °F in 5 °F increments	Used for alarm for when the DA air temperature is too high. Set high range of alarm; above this temperature the alarm will show on the display.
	DCVCAL ENA	MAN	MAN (manual) AUTO	Turns on the DCV automatic control of the dampers. Resets ventilation based on the RA, OA and MA sensor conditions. Requires all sensors (RA, OA, MA and CO <sub>2</sub> ). This operation is not operable with a 2-speed fan unit.
	MAT T CAL	0.0 F°	+/- 2.5 F°	Allows for the operator to adjust for an out-of-calibration temperature sensor.
	OAS T CAL	0.0 F°	+/- 2.5 F°	Allows for the operator to adjust for an out-of-calibration temperature sensor.
	OAS H CAL	0% RH	+/- 10% RH	Allows for the operator to adjust for an out-of-calibration humidity sensor.
	RA T CAL	0.0 F°	+/- 2.5 F°	Allows for the operator to adjust for an out-of-calibration temperature sensor.
	RA H CAL	0% RH	+/- 10% RH	Allows for the operator to adjust for an out-of-calibration humidity sensor.
	DA T CAL	0.0 F°	+/- 2.5 F°	Allows for the operator to adjust for an out-of-calibration temperature sensor.
	2SP FAN DELAY	5 Minutes	0 to 20 minutes in 1 minute increments	When in economizing mode, this is the delay for the high speed fan to try to satisfy the call for second stage cooling before the first stage mechanical cooling is enabled.
CHECKOUT ③	DAMPER MINIMUM POSITION	N/A	N/A	The checkout for the damper minimum positions is based on the system. See Table 8 on page 27.
	DAMPER OPEN	N/A	N/A	Positions damper to the full open position. Exhaust fan contacts enable during the DAMPER OPEN test. Make sure to pause in this mode to allow for exhaust contacts to energize due to the delay in the system.
	DAMPER CLOSE	N/A	N/A	Positions damper to the fully closed position.
	CONNECT Y1-O	N/A	N/A	Closes the Y1-O relay (Y1-O). ④
	CONNECT Y2-O	N/A	N/A	Closes the Y2-O relay (Y2-O). ④
	CONNECT AUX1-O	N/A	N/A	Energizes the AUX1-O output. If AUX1-O setting is: <ul style="list-style-type: none"> <li>• NONE – no action taken.</li> <li>• ERV – 24 Vac out. Turns on or signals an ERV that the conditions are not good for economizing but are good for ERV operation. ⑤</li> <li>• SYS – 24 Vac out. Issues a system alarm.</li> </ul>
	CONNECT EXH1	N/A	N/A	Closes the power exhaust fan 1 relay (EXH1)

N/A = Not Applicable

- ① Table 7 illustrates the complete hierarchy. Actual menu parameters may be different depending on the configuration. For example, if there is no DCV (CO<sub>2</sub>) sensor, then none of the DCV parameters appear.
- ② When values are displayed, pressing and holding the ▲ or ▼ button causes the display to automatically increment.
- ③ After 10 minutes without a command or mode change, the controller will change to normal operation.
- ④ Be sure to allow enough time for compressor startup and shutdown between checkout tests so that the compressors are not short cycled.
- ⑤ ERV Operation: When in cooling mode AND the conditions are NOT OK for economizing, the ERV terminal will be energized. In the heating mode, the ERV terminal will be energized when the OA is below the ERV OAT setpoint in the setpoint menu.

**TABLE 7F**  
**Menu Structure ① (cont.)**

Menu	Parameter	Parameter Default Value	Parameter Range and Increment ②	Notes
ALARMS(#)				Alarms display only when they are active. The menu title "ALARMS (#)" includes the number of active alarms in parenthesis (). When using SYLK bus sensors, "SYLK" will appear on the screen, and when using 20k OA temperature sensors, "SENS T" will appear on the screen.
	MA T SENS ERR	N/A	N/A	Mixed air sensor has failed or become disconnected. Check wiring then replace sensor if the alarm continues.
	CO2 SENS ERR	N/A	N/A	CO <sub>2</sub> sensor has failed, gone out of range or become disconnected. Check wiring then replace sensor if the alarm continues.
	OA SYLK T ERR	N/A	N/A	Outdoor air enthalpy sensor has failed or become disconnected. Check wiring then replace sensor if the alarm continues.
	OA SYLK H ERR	N/A	N/A	
	RA SYLK T ERR	N/A	N/A	Return air enthalpy sensor has failed or become disconnected. Check wiring then replace sensor if the alarm continues.
	RA SYLK H ERR	N/A	N/A	
	DA SYLK T ERR	N/A	N/A	Discharge air sensor has failed or become disconnected. Check wiring then replace sensor if the alarm continues.
	OA SENS T ERR	N/A	N/A	Outdoor air temperature sensor has failed or become disconnected. Check wiring then replace sensor if the alarm continues.
	ACT ERROR	N/A	N/A	Actuator has failed or become disconnected. Check for stall, over voltage, under voltage and actuator count. Replace actuator if damper is moveable and supply voltage is between 21.6 V and 26.4 V. Check actuator count on STATUS menu.
	FREEZE ALARM	N/A	N/A	Check if outdoor temperature is below the LOW Temp Lockout on setpoint menu. Check if mixed air temperature on STATUS menu is below the Lo Setpoint on Advanced setup menu. When conditions are back in normal range then the alarm will go away.
	SHUTDOWN ACTIVE	N/A	N/A	AUX2 IN is programmed for SHUTDOWN and 24 V has been applied to AUX 2 IN terminal
	DMP CAL RUNNING	N/A	N/A	If DCV Auto enable has been programmed, when the JADE is completing a calibration on the dampers, this alarm will display. Wait until the calibration is completed and the alarm will go away. Must have OA, MA and RA sensors for DCV calibration; set up is in the Advanced setup menu.
	DA SENS ALM	N/A	N/A	Discharge air temperature is out of the range set in the ADVANCED SETUP Menu. Check the temperature of the discharge air.
	SYS ALARM	N/A	N/A	When AUX1-0 is set to SYS and there is any alarm (e.g., failed sensors, etc.), the AUX1-0 terminal has 24 Vac out.
	ACT UNDER V	N/A	N/A	Voltage received by actuator is above expected range.
ACT OVER V	N/A	N/A	Voltage received by actuator is below expected range.	
ACT STALLED	N/A	N/A	Actuator stopped before achieving commanded position.	

N/A = Not Applicable

① Table 7 illustrates the complete hierarchy. Actual menu parameters may be different depending on the configuration. For example, if there is no DCV (CO<sub>2</sub>) sensor, then none of the DCV parameters appear.

② When values are displayed, pressing and holding the ▲ or ▼ button causes the display to automatically increment.

**TABLE 7G**  
**Menu Structure ① (cont.)**

Menu	Parameter	Parameter Default Value	Parameter Range and Increment ②	Notes
<b>Features Adjustable Only by Use of the W7220 PC MOD Tool</b>				
	ACT STALL ALARM SUPPRESSION	Disabled	Enabled or Disabled	If enabled, this feature allows the operator to suppress the stall alarm in a specific range of the actuator stroke.
	SELECT TYPE OF CONTROLLER	W7220	"W7220, W7218 or Pre-programmed special"	The operator can configure a program for a customer or job and save the program in the file. Found on the configuration page of the Trade version.
	ACTUATOR SLIPPAGE ALARM	Enabled	Enabled or Disabled	Alarms if the actuator becomes disconnected from the damper or is slipping on the shaft. If Enabled, the JADE system will complete a system air temperature check. If there is the expected change in system air temperature, then JADE assumes the actuator is connected to the damper. If the expected system air temperature changes do not occur, then an actuator slippage alarm is displayed on the JADE LCD. Found on the configuration page of the Trade version.
	ACTUATOR SLIPPAGE ALARM SENSITIVITY	Low	Low, Standard or High	Sensitivity can be set to HIGH, STANDARD or LOW. High means the system will check 5 times for the damper to move before displaying the alarm. Standard is 10 times before the alarm is displayed. Low is 20 times before the alarm is displayed. Found on the economizer page of the Trade version.
	LOCATION OF ECONOMIZER CONTROL SENSOR	Before the cooling coil	Before coil or AUTO	The operator can choose if the economizer control sensor (normally referred to as the mixed air sensor) is placed in the mixed air (before the coil) or Auto in the case the sensor is placed after the cooling coil. Found on the configuration page of the Trade version.
	DAMPER AIA THRESHOLD	15 degrees	5 to 40 degrees	Damper threshold feature (Adaptive Integral Action) is the difference in the mixed air temperature reported by the MAT sensor and the MAT setpoint. Lower (2 degrees) transfer rate between the actual MAT sensor reading and the MAT setpoint normally means the damper is closing and opening faster. Larger transfer rate (up to 20 degrees) between the sensor reading and the setpoint normally means the damper is opening and closing slower. Used in applications where there is a large MA space or there is a long duct between the OA and the MA causing a delay. Found on the economizer page of the Trade version.

- ① Table 7 illustrates the complete hierarchy. Actual menu parameters may be different depending on the configuration. For example, if there is no DCV (CO<sub>2</sub>) sensor, then none of the DCV parameters appear.
- ② When values are displayed, pressing and holding the ▲ or ▼ button causes the display to automatically increment.

**TABLE 8**  
**Damper Minimum Position Settings and Readings on Checkout Menu**

Fan Speed	Demand Control Ventilation (CO <sub>2</sub> Sensor)	Setpoints	Checkout
1	NO	MIN POS	VMAX-HS
1	NO	N/A	N/A
2	NO	MIN POS H	VMAX-HS
2	NO	MIN POS L	VMAX-LS
1	YES	VENT MIN	VMAX-HS
1	YES	VENT MAX	VMAX-LS
2	YES	VENT MIN H	VMAX-HS
2	YES	VENT MAX H	VMAX-LS
2	YES	VENT MIN L	N/A
2	YES	VENT MAX L	N/A

**TABLE 9**  
**Dry Bulb Operation No DCV (CO<sub>2</sub> Sensor) – 2 Speed Fan**

DCV	OA Good to economize?	Y1-I	Y2-I	FAN SPD	Y1-O	Y2-O	Occupied	Unoccupied
None	No	Off	Off	Low	0-v/Off	0-w/Off	MIN POS L	Closed
		On	Off	Low	24-v/On	0-w/Off	MIN POS L	Closed
		On	On	High	24-v/On	24-v/On	MIN POS H	Closed
None	Yes	Off	Off	Low	0-v/Off	0-w/Off	MIN POS L	Closed
		On	Off	Low	0-v/Off	0-w/Off	MIN POS L to Full-Open	Closed to Full-Open
		On	On	High	DELAY ① 24-v/On	0-w/Off ②	MIN POS H to Full-Open	Closed to Full-Open

- ① With 2SP FAN DELAY (Advanced Setup Menu) when in the economizing mode, there is a delay for the high speed fan to try to satisfy the call for second stage cooling by turning on the fan to high and opening the OA damper 100% before the first stage mechanical cooling is enabled.
- ② With stage 3 delay (STG3 DLY) in Advanced setup menu, can turn on 2nd stage of mechanical cooling Y2–O after the delay if the call for Y1-I and Y2-I have not been satisfied.

**TABLE 10**  
**Dry Bulb Operation with DCV (CO<sub>2</sub> Sensor) – 2 Speed Fan**

DCV	OA Good to economize?	Y1-I	Y2-I	FAN SPD	Y1-O	Y2-O	Occupied	Unoccupied
Below Set	No	Off	Off	Low	0-v/Off	0-w/Off	VENTMIN L	Closed
		On	Off	Low	24-v/On	0-w/Off	VENTMIN L	Closed
		On	On	High	24-v/On	24-v/On	VENTMIN H	Closed
	Yes	Off	Off	Low	0-v/Off	0-w/Off	VENTMIN L	Closed
		On	Off	Low	0-v/Off	0-w/Off	"VENTMIN L to Full-Open"	Closed to Full-Open
		On	On	High	24-v/On	0-w/Off ②	"VENTMIN H to Full-Open"	Closed to Full-Open
Above Set	No	Off	Off	Low	0-v/Off	0-w/Off	VENTMIN L to VENTMAX	Closed
		On	Off	Low	24-v/On	0-w/Off	VENTMIN L to VENTMAX	Closed
		On	On	High	24-v/On	24-v/On	VENTMIN H to VENTMAX	Closed
	Yes	Off	Off	Low	0-v/Off	0-w/Off	VENTMIN L to VENTMAX	Closed
		On	Off	Low	0-v/Off	0-w/Off	"VENTMIN L to Full-Open"	Closed to Full-Open
		On	On	High	DELAY ① 24-v/On	0-w/Off ②	"VENTMIN H to Full-Open"	Closed to Full-Open

- ① With 2SP FAN DELAY (Advanced Setup Menu) when in the economizing mode, there is a delay for the high speed fan to try to satisfy the call for second stage cooling by turning on the fan to high and opening the OA damper 100% before the first stage mechanical cooling is enabled.
- ② With stage 3 delay (STG3 DLY) in Advanced setup menu, can turn on 2nd stage of mechanical cooling Y2–O after the delay if the call for Y1-I and Y2-I have not been satisfied.

**TABLE 11**  
**Enthalpy Operation No DCV (CO<sub>2</sub> Sensor) – 2 Speed Fan**

DCV	OA Good to economize?	Y1-I	Y2-I	FAN SPD	Y1-O	Y2-O	Occupied	Unoccupied
NO CO <sub>2</sub> SENSOR	No	Off	Off	Low	0-v/Off	0-v/Off	MIN POS L	Closed
		On	Off	Low	24-v/On	0-v/Off	MIN POS L	Closed
		On	On	High	24-v/On	24-v/On	MIN POS H	Closed
	Yes	Off	Off	Low	0-v/Off	0-v/Off	MIN POS L	Closed
		On	Off	Low	0-v/Off	0-v/Off	MIN POS L to Full-Open	Closed to Full-Open
		On	On	High	DELAY ① 24-v/On	0-v/Off ②	MIN POS H to Full-Open	Closed to Full-Open

- ① With 2SP FAN DELAY (Advanced Setup Menu) when in the economizing mode, there is a delay for the high speed fan to try to satisfy the call for second stage cooling by turning on the fan to high and opening the OA damper 100% before the first stage mechanical cooling is enabled.
- ② With stage 3 delay (STG3 DLY) in Advanced setup menu, can turn on 2nd stage of mechanical cooling Y2-O after the delay if the call for Y1-I and Y2-I have not been satisfied.

**TABLE 12**  
**Enthalpy Operation with DCV (CO<sub>2</sub> Sensor) – 2 Speed Fan**

DCV	OA Good to economize?	Y1-I	Y2-I	FAN SPD	Y1-O	Y2-O	Occupied	Unoccupied
Below Set	No	Off	Off	Low	0-v/Off	0-v/Off	VENTMIN L	Closed
		On	Off	Low	24-v/On	0-v/Off	VENTMIN L	Closed
		On	On	High	24-v/On	24-v/On	VENTMIN H	Closed
	Yes	Off	Off	Low	0-v/Off	0-v/Off	VENTMIN L	Closed
		On	Off	Low	0-v/Off	0-v/Off	"VENTMIN L to Full-Open"	Closed to Full-Open
		On	On	High	24-v/On	0-v/Off ②	"VENTMIN H to Full-Open"	Closed to Full-Open
Above Set	No	Off	Off	Low	0-v/Off	0-v/Off	VENTMIN L to VENTMAX	Closed
		On	Off	Low	24-v/On	0-v/Off	VENTMIN L to VENTMAX	Closed
		On	On	High	24-v/On	24-v/On	VENTMIN H to VENTMAX	Closed
	Yes	Off	Off	Low	0-v/Off	0-v/Off	VENTMIN L to VENTMAX	Closed
		On	Off	Low	0-v/Off	0-v/Off	"VENTMIN L to Full-Open"	Closed to Full-Open
		On	On	High	DELAY ① 24-v/On	0-v/Off ②	"VENTMIN H to Full-Open"	Closed to Full-Open

- ① With 2SP FAN DELAY (Advanced Setup Menu) when in the economizing mode, there is a delay for the high speed fan to try to satisfy the call for second stage cooling by turning on the fan to high and opening the OA damper 100% before the first stage mechanical cooling is enabled.
- ② With stage 3 delay (STG3 DLY) in Advanced setup menu, can turn on 2nd stage of mechanical cooling Y2-O after the delay if the call for Y1-I and Y2-I have not been satisfied.



---

# REPLACEMENT PARTS MANUAL

---

## IZ Commercial Ventilator and Economizer

Models:  
IZ-CRV IZ-ECON

---

### Contents

Description	Page
Left Intake Blade Assembly	
♦ Layout View .....	2
♦ Usage List .....	3
Right Intake Blade Assembly	
♦ Layout View .....	4
♦ Usage List .....	5
Intake Actuator Assembly	
♦ Exploded View .....	6
♦ Usage List .....	7
Exhaust Actuator Assembly	
♦ Exploded View .....	8
♦ Usage List .....	9
Exhaust Duct Assembly	
♦ Exploded View .....	10
♦ Usage List .....	11
Blower Assembly	
♦ Layout View .....	12
♦ Usage List .....	13
Vent Box Assembly	
♦ Exploded View .....	14
♦ Usage List .....	15

Description	Page
Control Panel Assembly – CRV/ECON (NC)	
♦ Layout View .....	16
♦ Usage List .....	17
Control Panel Assembly – ECON (DB)/ECON (WB)	
♦ Layout View .....	18
♦ Usage List .....	19

### General Notes

- Revised and/or additional pages may be issued from time to time.
- A complete and current manual consists of pages shown in the following contents section.

### Important

- Contact the installing and/or local Bard distributor for all parts requirements. Make sure to have the complete model and serial number available from the unit rating plates.



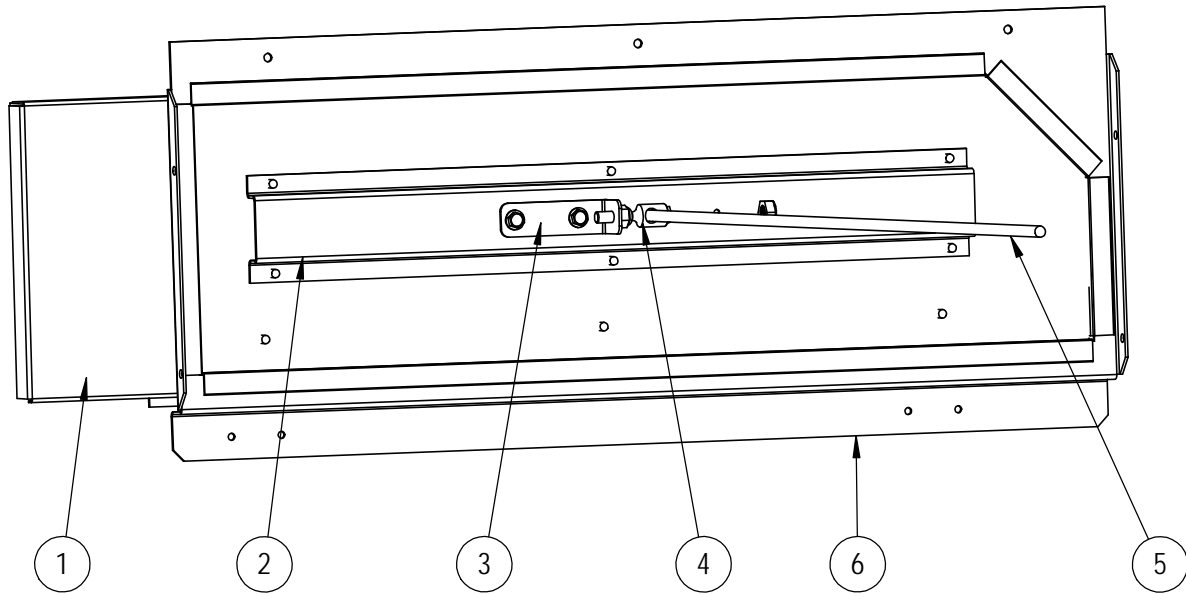
Climate Control Solutions

Bard Manufacturing Company, Inc.  
Bryan, Ohio 43506  
www.bardhvac.com

Manual: 2110-1148  
Supersedes: **NEW**  
Date: 2-27-23

# LEFT INTAKE BLADE ASSEMBLY

---



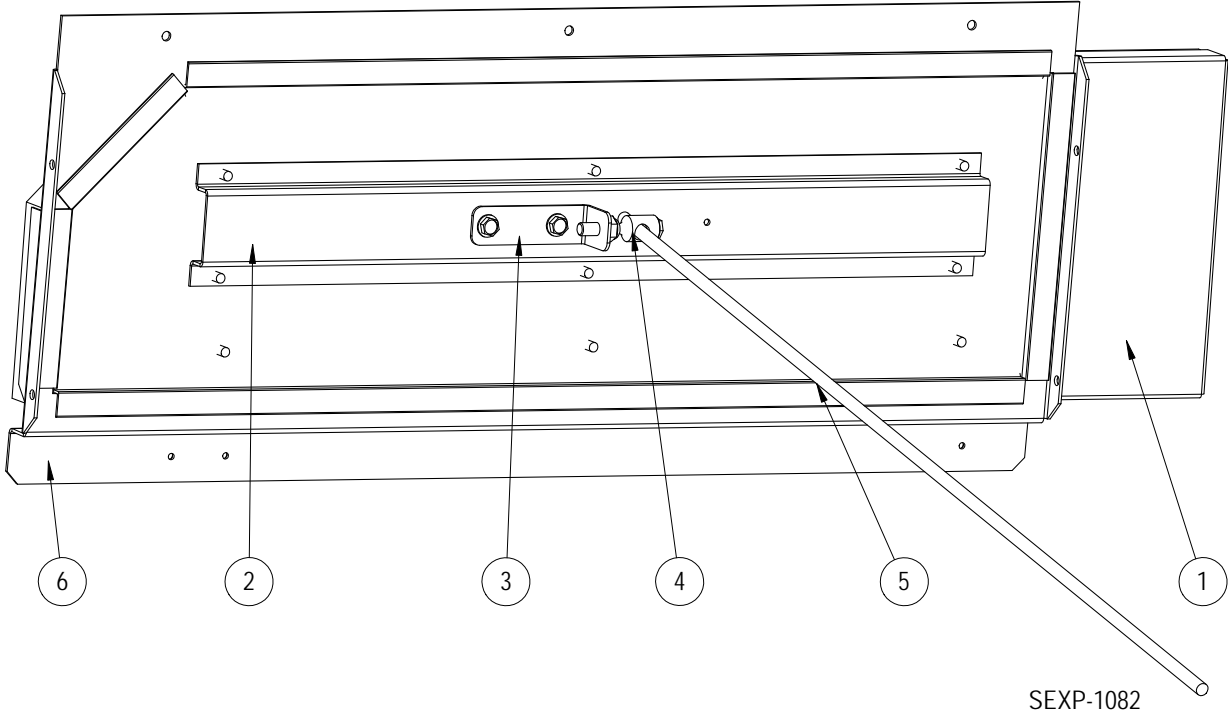
SEXP-1081

## LEFT INTAKE BLADE ASSEMBLY

---

<b>Drawing No.</b>	<b>Part No.</b>	<b>Description</b>	<b>All Vents</b>
1	539Y464BX	Left Intake Blade	x
2	141-568BX	Intake Blade Support	x
3	113-772BX	Ball Joint Bracket	x
4	8602-008	Ball Joint	x
5	8602-119	25" Rod	x
6	537Y1019BX	Left Econ Intake Partition	x
NS	5400-010	Metal Leaf Hinge	2

# RIGHT INTAKE BLADE ASSEMBLY



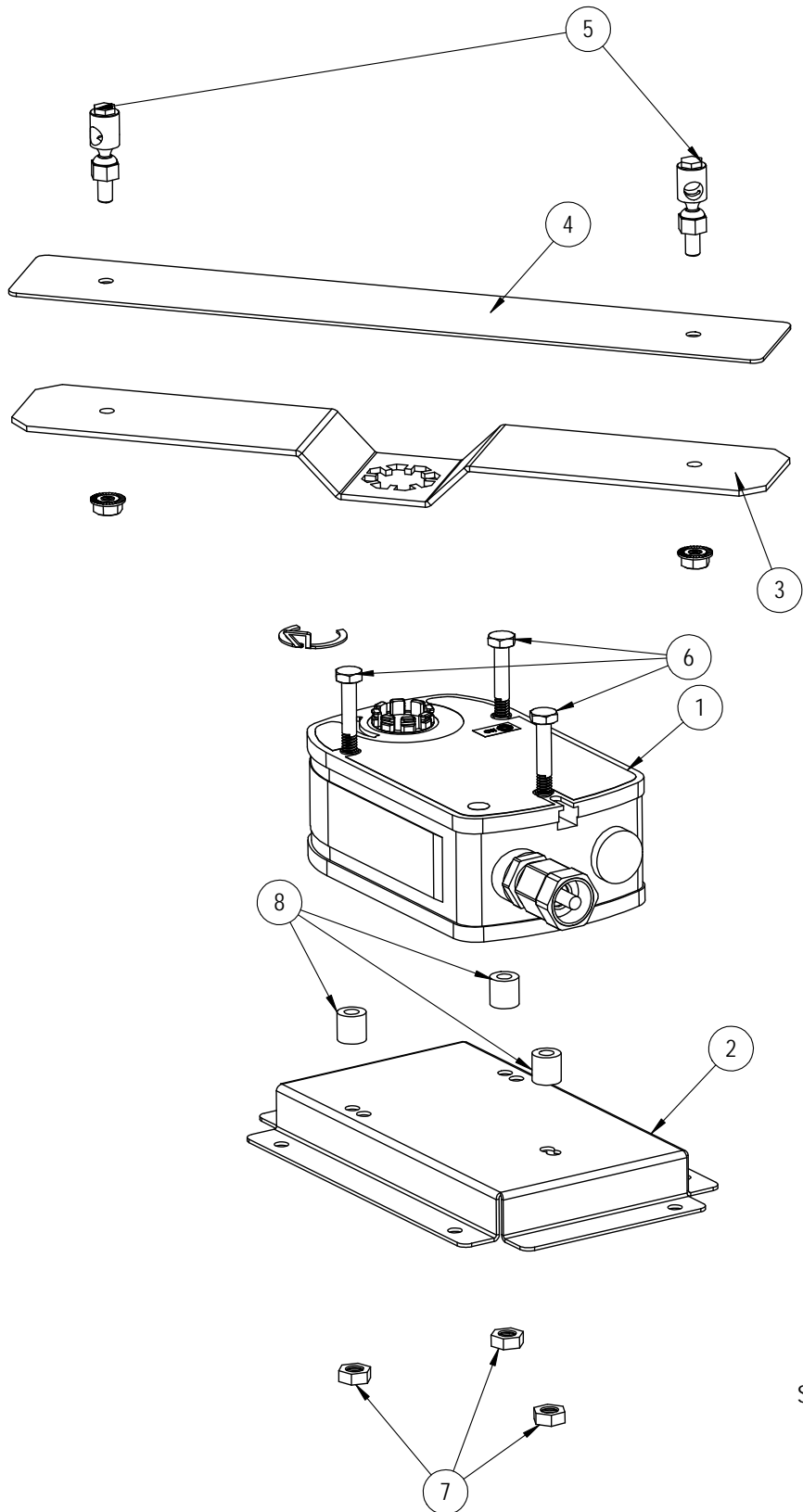
## RIGHT INTAKE BLADE ASSEMBLY

---

<b>Drawing No.</b>	<b>Part No.</b>	<b>Description</b>	<b>All Vents</b>
1	539X464BX	Right Intake Blade	x
2	141-568BX	Intake Blade Support	x
3	113-772BX	Ball Joint Bracket	x
4	8602-008	Ball Joint	x
5	8602-119	25" Rod	x
6	537X1019BX	Right Econ Intake Partition	x
NS	5400-010	Metal Leaf Hinge	2

# INTAKE ACTUATOR ASSEMBLY

---



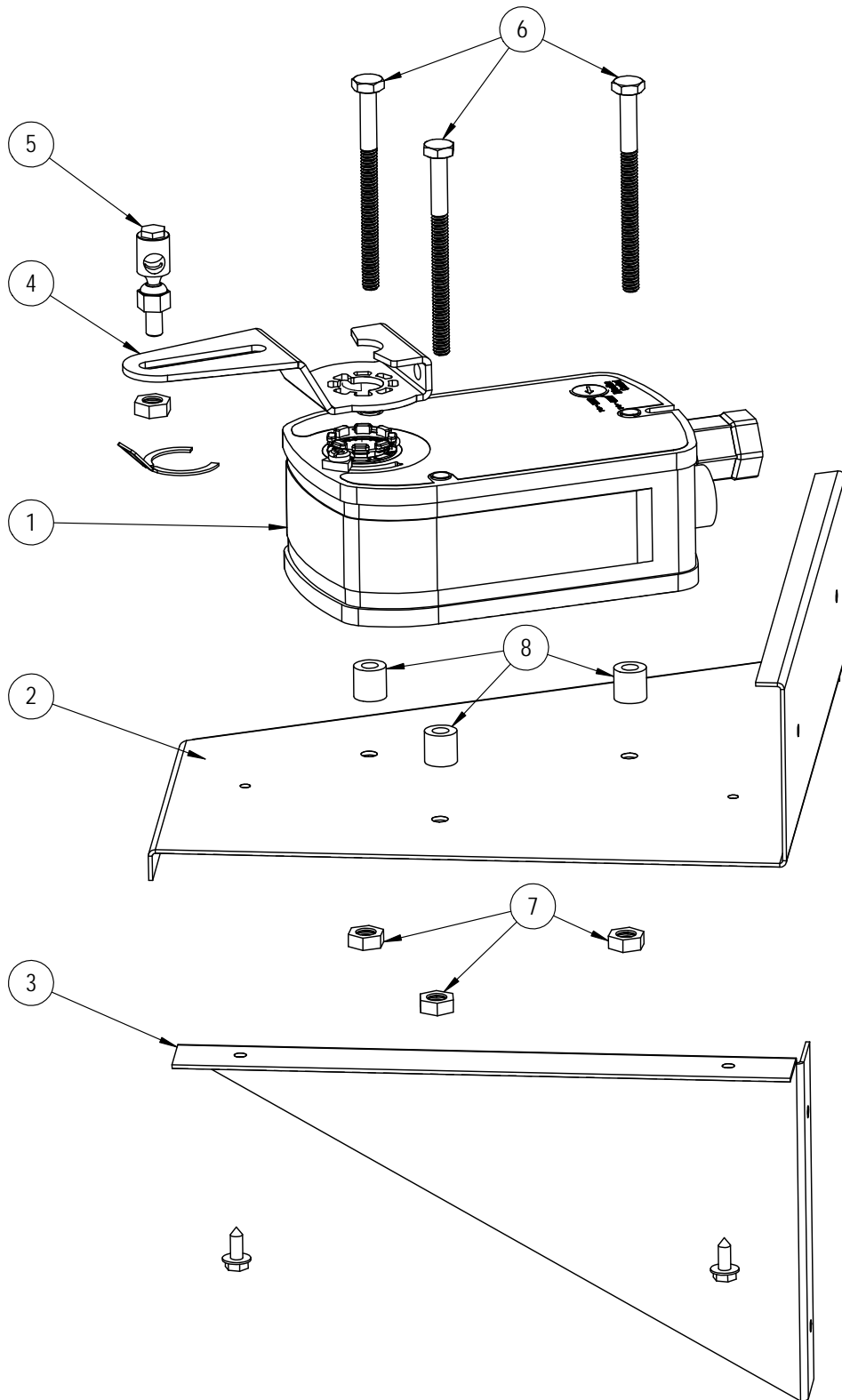
SEXP-1083

# INTAKE ACTUATOR ASSEMBLY

---

Drawing No.	Part No.	Description	CRV and ECON (No Control)	ECON
1	8602-075BX	Actuator	X	
1	8602-059BX	Actuator		X
2	141-495BX	Actuator Plate	X	X
3	139-463BX	Actuator Arm	X	
3	139-465BX	Actuator Arm		X
4	141-567BX	Actuator Arm Support	X	X
5	8602-008	Ball Joint	2	2
6	1012-174	1/4" -20 X 3-1/4 Hex Cap Screw	3	3
7	1012-201	1/4-20 Steel keps Hex Nut	3	3
8	5451-029	Nylon Sleeve .257" ID X .5" Long	3	3
NS	3000-1623BX	Actuator Harness		X

# EXHAUST ACTUATOR ASSEMBLY



SEXP-1080

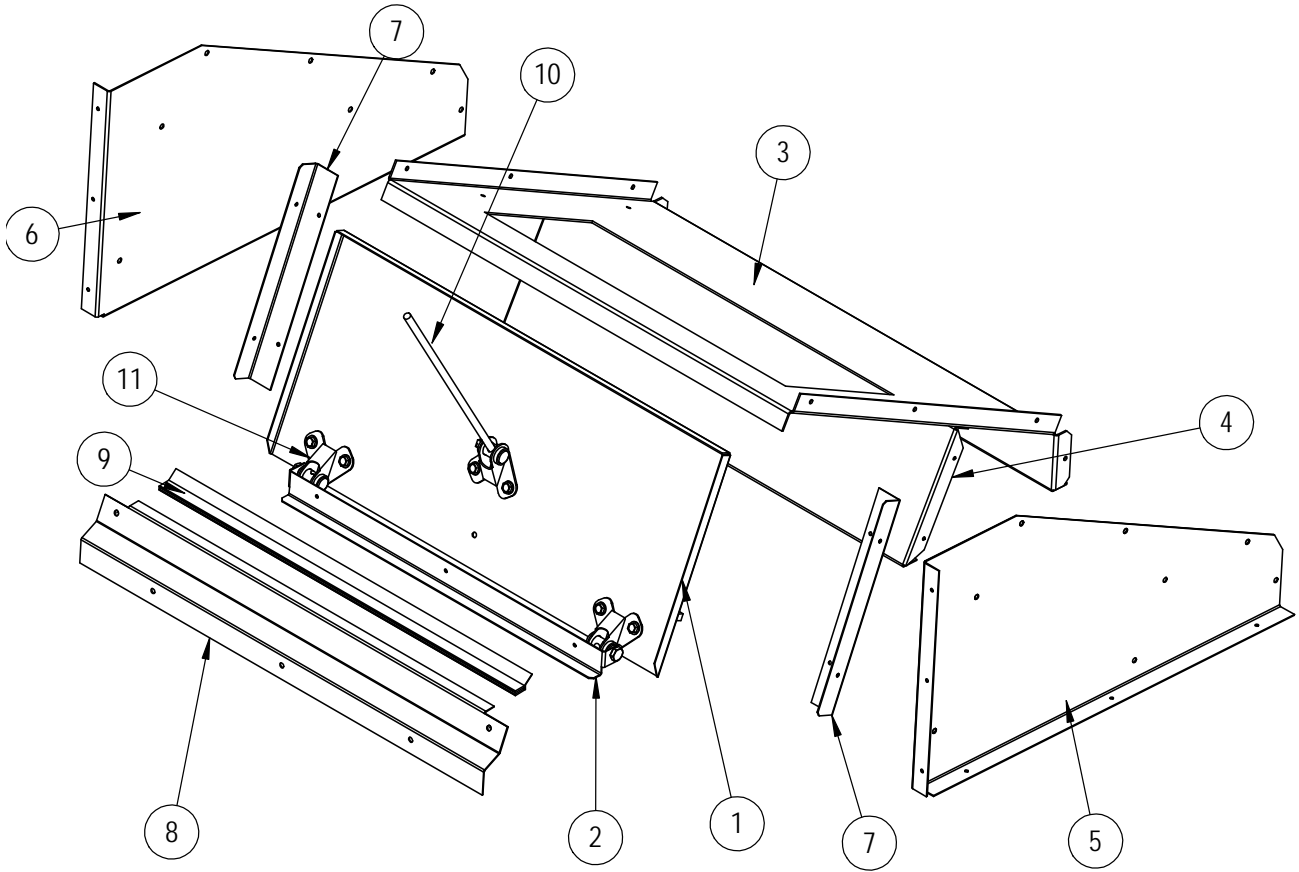
## EXHAUST ACTUATOR ASSEMBLY

---

Drawing No.	Part No.	Description	All Vents
1	8602-118BX	Actuator	X
2	141-565BX	Actuator Plate	X
3	141-566BX	Actuator Support Plate	X
4	8602-078BX	Actuator Arm	X
5	8602-008	Ball Joint	X
6	1012-174	1/4" -20 X 3-1/4 Hex Cap Screw	3
7	1012-201	1/4-20 Steel Keps Hex Nut	3
8	5451-029	Nylon Sleeve .257" ID X .5" Long	3

# EXHAUST DUCT ASSEMBLY

---



SEXP-1078

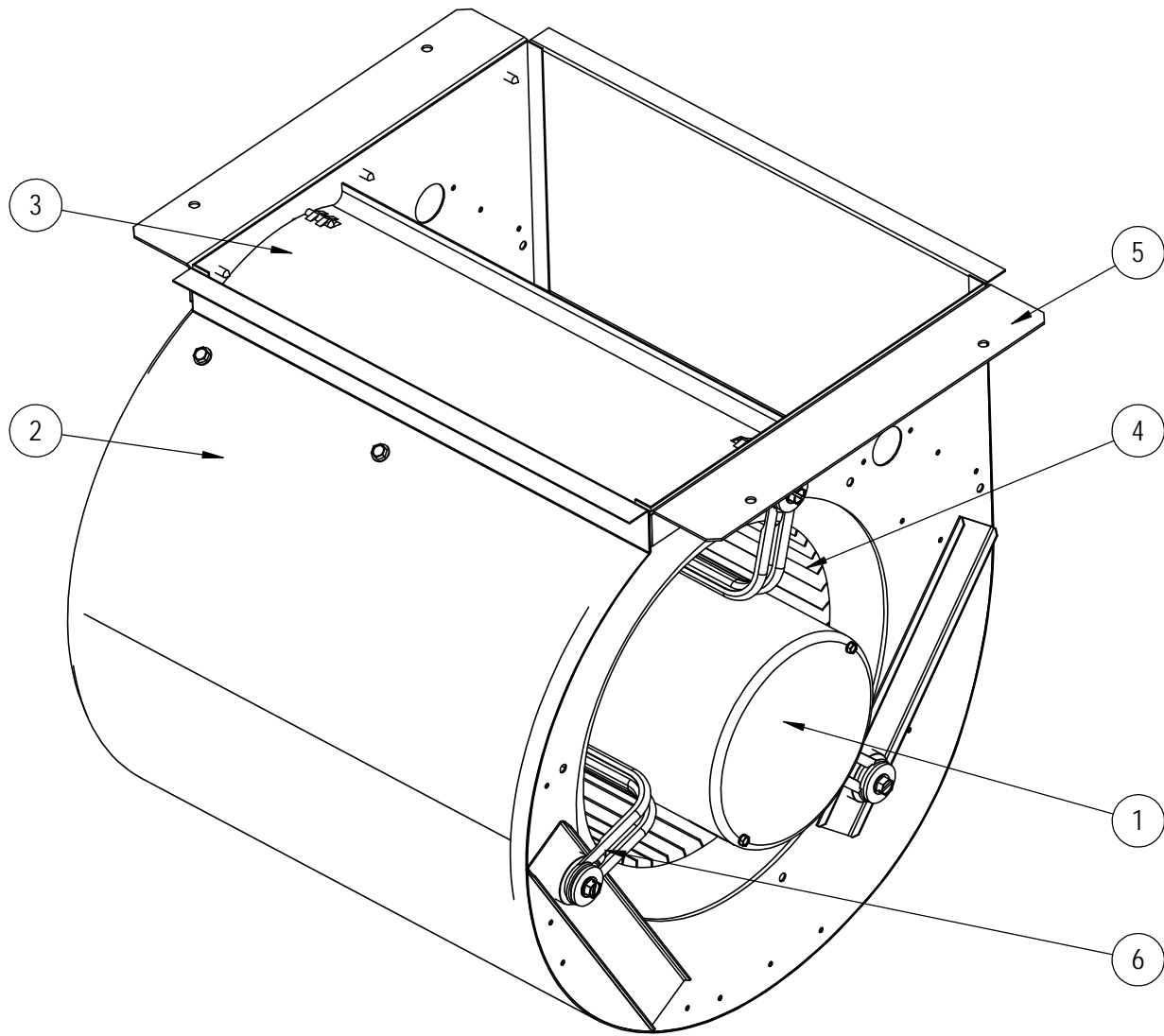
## EXHAUST DUCT ASSEMBLY

---

Drawing No.	Part No.	Description	All Vents
1	539-462BX	Exhaust Blade	x
2	113-954BX	Damper Pivot Bracket	x
3	141-564BX	Blower Support	x
4	113-955BX	Air Deflector	x
5	101X1148BX	Duct Right Side	x
6	101Y1148BX	Duct Left Side	x
7	105-1529BX	Side Angle	2
8	113-952BX	Damper Seal Brackets	1
9	1921-067-1700	17" Damper Seal	x
10	8602-083	10" Rod	x
11	8602-040	Hinge	3
NS	113-972BX	Exhaust Blade Support	x
NS	1012-348	Nylon Washer	2
NS	1012-343	1/4-28 Bolt	2

# BLOWER ASSEMBLY

---



SEXP-1084

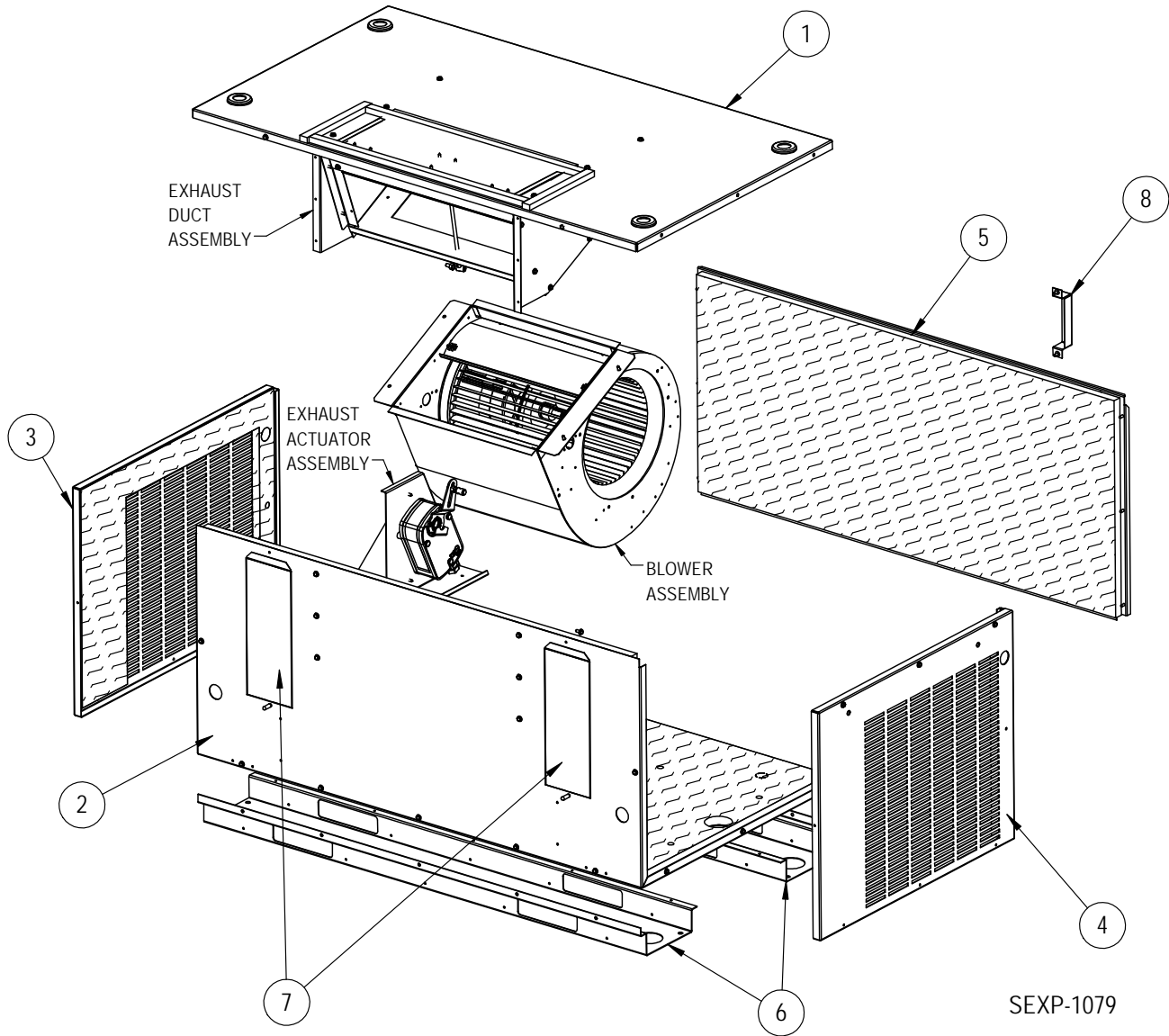
# BLOWER ASSEMBLY

---

900-399-001

Drawing No.	Part No.	Description	
1	8106-072-0243BX	Blower Motor and Control (230/208V)	X
2	151-128BX	Housing	X
3	144-210BX	Diffuser	X
4	5152-061BX	Wheel	X
5	104-1530BX	Side Angle	2
6	8200-036	Motor Mount Leg	3
NS	8200-033	Motor Mount Band	X
NS	3000-1331BX	Power Harness	X
NS	910-2187BX	Low Voltage Harness	X

# VENT BOX ASSEMBLY

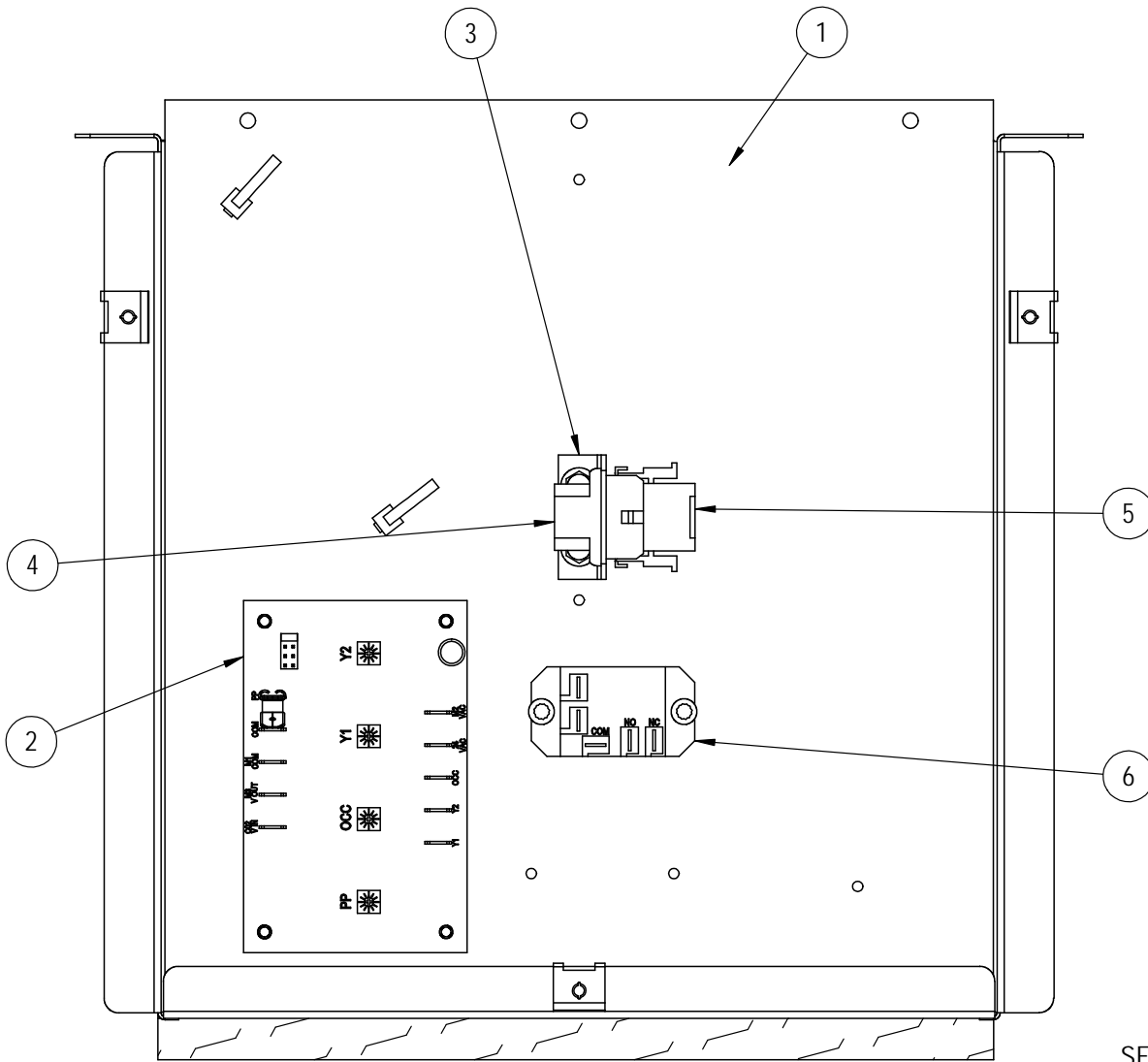


## VENT BOX ASSEMBLY

---

Drawing No.	Part No.	Description	All Vents
1	507-414BX	Top	X
2	527-620BX	Base	X
3	501-1146BX	Right Side	X
4	501-1147BX	Left Side	X
5	553-765BX	Vent Door	X
6	141-478BX	Base Rail	2
7	543-158BX	Drain Access Plate	2
8	113-441BX	Door Latch Bracket	X
NS	3000-1741	Vent Box Harness	X

# CONTROL PANEL ASSEMBLY – CRV/ECON (NC)



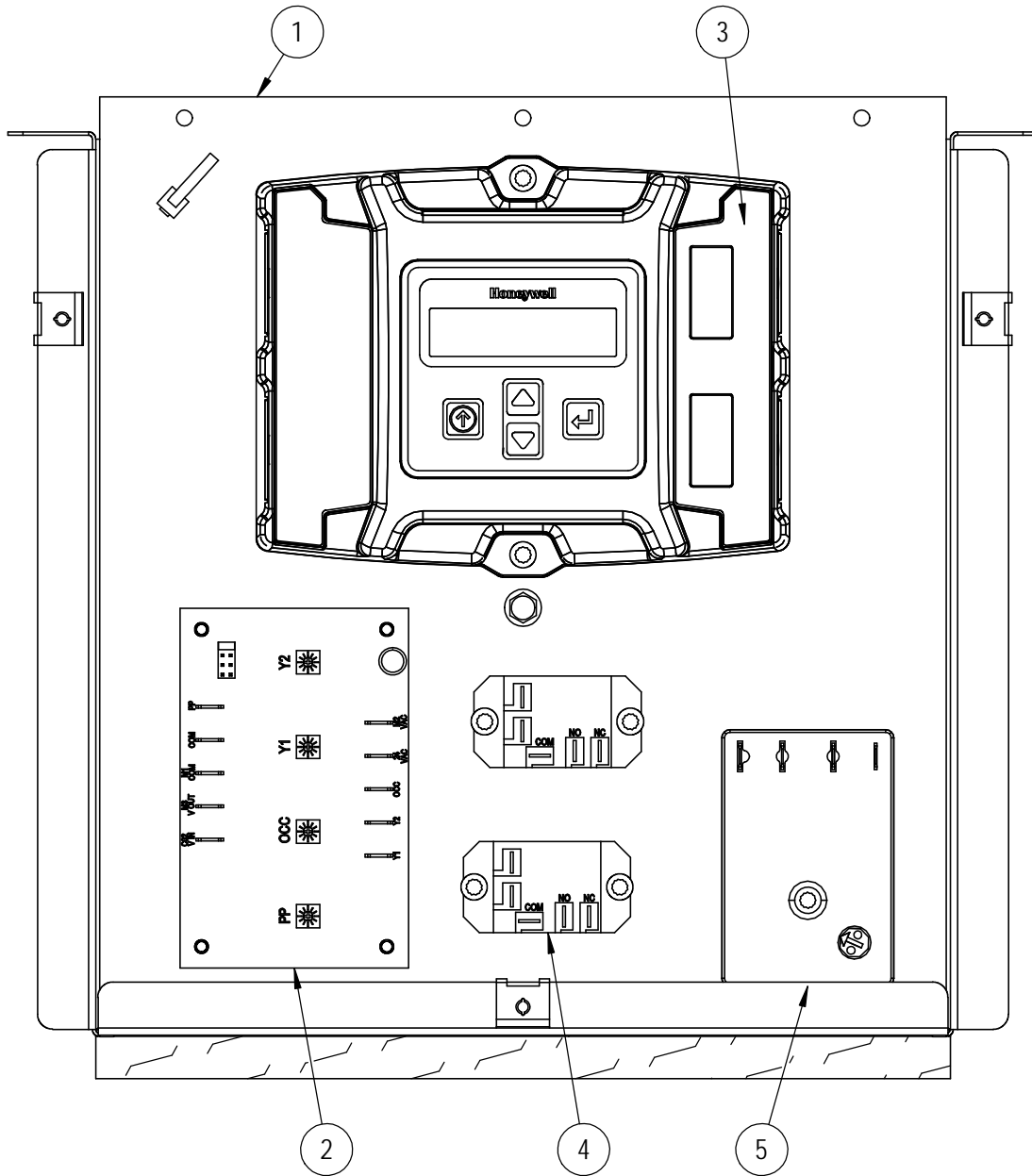
SEXP-1085

## CONTROL PANEL ASSEMBLY – CRV/ECON (NC)

---

Drawing No.	Part No.	Description	CRV	ECON (No Control)
1	117-450BX	Vent Control Box	X	X
2	8201-167BX	CRV Control Board	X	
3	141-443BX	Plug Support Bracket	X	X
4	3000-1745BX	Voltage Divide Female Plug	X	X
5	3000-1746BX	Voltage Divide Male Plug	X	X
6	8201-130BX	Relay	X	
NS	3000-1742BX	Actuator and Blower Harness	X	X
NS	3000-1744BX	12-Pin Vent Harness	X	
NS	3000-1447BX	12-Pin Vent Harness		X

# CONTROL PANEL ASSEMBLY – ECON (DB)/ECON (WB)



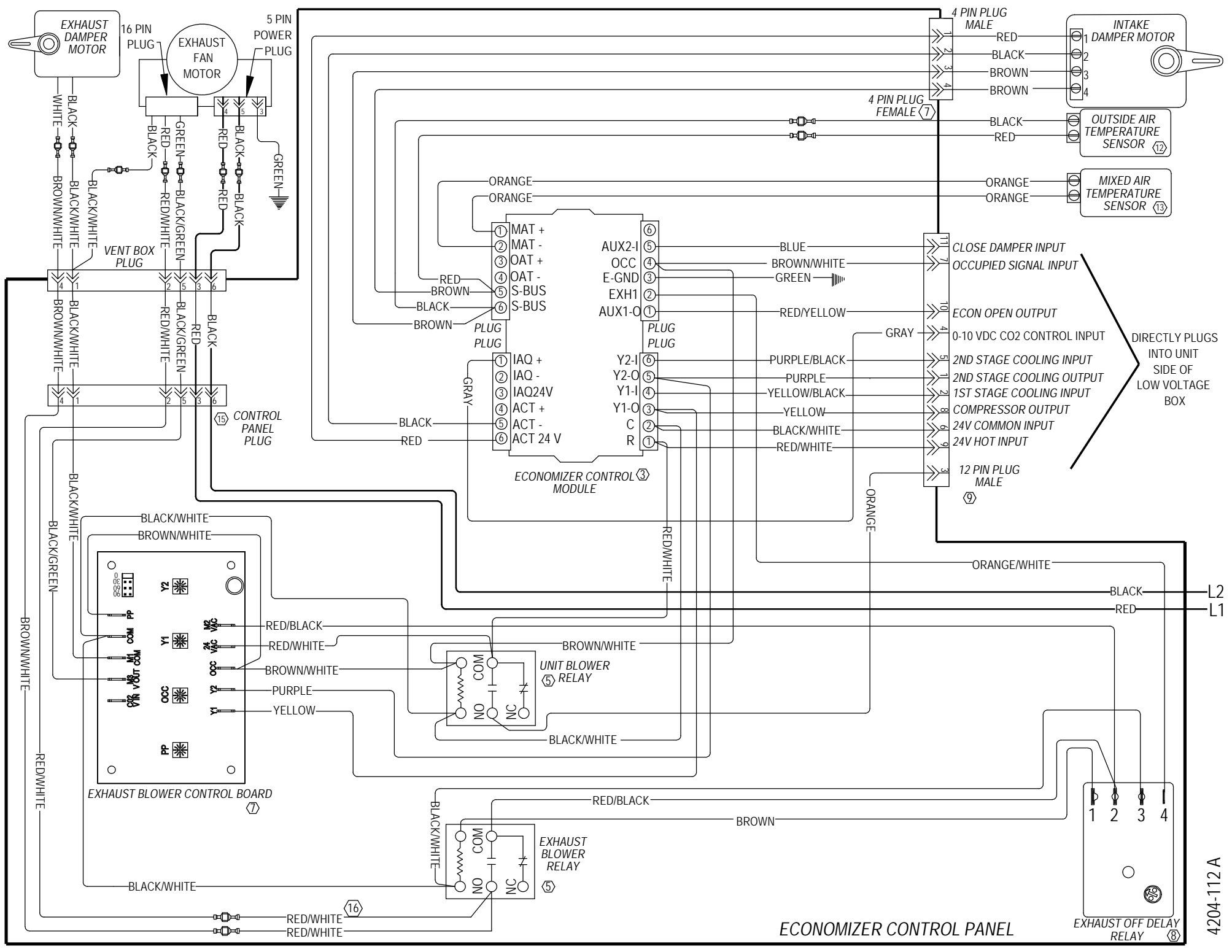
SEXP-1086

## CONTROL PANEL ASSEMBLY – ECON (DB)/ECON (WB)

---

Drawing No.	Part No.	Description	ECON (Dry Bulb)	ECON (Enthalpy Bulb)
1	117-450BX	Vent Control Box	X	X
2	8201-167BX	CRV Control Board	X	X
3	8602-056-0007BX	Programmed Economizer Module	X	X
4	8201-130BX	Relay	2	2
5	8201-152BX	Exhaust Off Delay Relay	X	X
NS	3000-1742BX	Actuator and Blower Harness	X	X
NS	3003-125BX	12-Pin Vent Harness	X	X
NS	3000-140BX	Vent Harness		X
NS	3000-143BX	Vent Harness	X	
NS	910-2224BX	Sensor Assembly (Indoor)	X	X
NS	910-2225BX	Sensor Assembly (Outdoor)		X
NS	910-2226BX	Sensor Assembly (Outdoor)	X	





ECONOMIZER CONTROL PANEL

4204-112 A