



Climate Control Solutions

Literature Assembly

911-0912

Book 1 of 2

Contains the following:

2100-034(G)
2100-810
2110-1587
7960-420(A)

User's Guide
Safety, Service, & Decomm.
Replacement Parts Manual
Warranty



USER'S APPLICATION GUIDE AND TECHNICAL PRODUCT OVERVIEW

Manual: 2100-034G
Supersedes: 2100-034F
Date: 12-17-20

Bard Manufacturing Company, Inc.
Bryan, Ohio 43506
www.bardhvac.com



BARDHVAC.COM

Climate Control Solutions

General Information

The User's Application Guide covers a wide range of heating and cooling products manufactured by Bard Manufacturing Company. It is intended to be a general guide for care and operation of typical systems and covers the most important features you should be aware of and are responsible for as the user of the equipment.

Because our product offerings are so varied and can be equipped with many features and options, it is not possible to cover all aspects of what your specific system may be configured for. Some systems may be quite simple in features to provide basic cooling and possibly heating, while other systems may also incorporate various ventilation technologies, dehumidification circuits and many different internal controls as well as room temperature controls. Therefore, you should request a detailed operation sequence and explanation of any special features from your installer and/or service company and also have them instruct you as to any routine maintenance procedures you are responsible for.

Contents

Overview	3	Unit Operation	18
Documentation	4	Air-to-Air Cooling Products (Air Conditioners)	18
Unit Literature Assembly – Documentation Provided with Your Units	4	Air-to-Air Cooling and Heating Products (Heat Pumps)	18
Unit Installation	5	Cooling Mode	18
WALL MOUNT Products – Mounting the Product on Wall Surface	5	Heating Mode	18
WALL MOUNT Products – Clearances for Outdoor Condenser Fan Airflow	6	Water-to-Air Cooling and Heating Products (Geothermal Heat Pumps)	19
WALL MOUNT Products – Clearances for Indoor Supply and Return Airflow	6	Cooling Mode	19
WALL MOUNT Products – Condensate and Defrost Drainage	7	Heating Mode	19
I-TEC and Q-TEC Products – Installing the Product Inside a Room	8	Water Supply Systems	19
I-TEC and Q-TEC Products – Clearances for Outdoor Condenser Fan Airflow	8	Dehumidification and Ventilation Operation.....	20
I-TEC and Q-TEC Products – Clearances for Indoor Supply and Return Airflow	9	Dehumidification (Air-to-Air or Water-to-Air Systems)	20
I-TEC Air Path	9	Ventilation Options (Air-to-Air or Water-to-Air Systems)	20
Q-TEC Air Path	9	Troubleshooting	21
I-TEC and Q-TEC Products – Condensate Drainage .	10	All Units – Troubleshooting	21
All Products – Power Supply Verification	11		
Field-Supplied Voltage	11		
Single and Three Phase Power	11		
Hertz (Frequency)	11		
Unit Maintenance	12		
All Products – Filters and Filter Servicing	12		
Outdoor Unit Wall Mount Room Air Filters	12		
WALL MOUNT Products – Filters and Filter Servicing	13		
I-TEC Indoor Products – Filters and Filter Servicing	14		
Q-TEC Indoor Products – Filters and Filter Servicing	15		
All Products – Coil Cleaning	16		
Equipment Corrosion Protection	16		
All Products – Condenser Airflow	17		

The User's Application Guide and Technical Product Overview covers the following products:



WALL MOUNT
Air Conditioners
and Heat Pumps



I-TEC®
Air Conditioners
and Heat Pumps



Q-TEC™
Air Conditioners
and Heat Pumps

The User's Application Guide and Technical Product Overview covers the following topics:

- Documentation provided by Bard for proper use of your new product.
- Unit installation guidelines.
- Routine unit maintenance.
- Unit operation.
- Unit troubleshooting.

Please use this guide as a general overview regarding unit application, maintenance and troubleshooting. Refer to product installation instructions and supplemental documentation provided with the unit or go to www.bardhvac.com for detailed individual product information.

Documentation

There are two sources of valuable information for your new Bard product:

- Documentation provided with your unit, normally located inside the unit control panel during shipping. This information should be saved once the unit is installed for future maintenance reference or to answer questions about equipment after installation.
- Documentation provided on the internet at www.bardhvac.com. This may be accessed from a desktop computer at the office, a laptop or an internet-capable cell phone at the worksite. Up-to-date documentation is available, along with specification sheets and other valuable resources regarding your new Bard product.

Unit Literature Assembly – Documentation Provided with Your Unit

Bard products are shipped with documentation that when used by a technician with cooling and heating knowledge, can ensure that your product is installed safely, performs optimally and achieves the longest life cycle possible.

Shipped literature includes the following:

- User Manual (this document)
- Installation Instructions
- Replacement Parts Manual
- Wiring Diagrams
- Warranty Information

Installation plays a key part in unit functionality, performance and safety. Product securing and placement, duct design and supply/return location, electrical routing and condensate and defrost drainage all play key roles in making sure a unit will perform per the design specifications.

WALL MOUNT Products – Mounting the Product on a Wall Surface



Outdoor products are normally mounted to an exterior wall surface, including brick, cement block, metal or wood construction. These products are labeled as “WALL MOUNT” units. **Before installation begins, the wall surface should be inspected by a construction professional to ensure it will support the weight of the unit and accessory items.** Approximate weights are available from the product specification sheet, and a safety factor should be designed into the installation. Typical fasteners to attach the unit to the wall using the integrated mounting flanges on both sides of the unit include tap cons, bolts, studs and other fastening devices. The selection of the fasteners to be used needs to be reviewed by a construction professional and decided upon based on the wall construction and fastener strength required. It is important to follow all guidelines and procedures covered in the installation instructions manual provided for the product.

Built-In Mounting Flange Detail:

Outdoor WALL MOUNT products include a mounting flange that is part of the cabinet construction. $\varnothing.375$ " holes are provided for unit mounting unless specified otherwise in installation instructions.

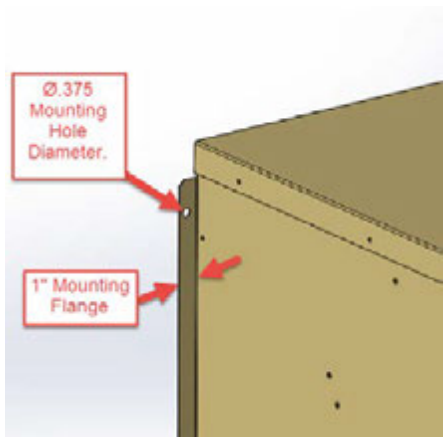

Specification Sheets:

Unit specification sheets provided at www.bardhvac.com include basic unit weights and dimensions (see example below). Ventilation options and other accessories must be added into the total weight of the unit.

Specification Sheet Example

w/Filter (Rated-wet Coil)	
Filter Sizes (inches) STD.	16x25x1
Basic Unit Weight-LBS.	318
Barometric Fresh Air Damper	3.5
Blank-Off Plate	1.0
Motorized Fresh Air Damper	10.0
Commercial Room Ventilator	69.0
Economizer	69.0
Energy Recovery Ventilator	50.0

WALL MOUNT Products – Clearances for Outdoor Condenser Fan Airflow

Unit placement and avoidance of obstructions outside the structure are very critical to unit performance. **Avoid installing the unit in areas that will obstruct outdoor condenser fan airflow or create “pockets” of heated air being exhausted from the condenser coil.** Solid construction fences should not be placed directly in front of the unit without provisions for condenser airflow. Solid exterior walls need to be spaced as far away from units as possible to avoid pockets of heated air causing condenser air recirculation.

Solid barriers located too close to the face or side surfaces (condenser fan inlet and outlet) of the WALL MOUNT can both impede airflow and force heated air to short circuit (be returned) from the condenser outlet to the condenser inlet. Either condition will effectively raise the condensing temperature and pressure reducing cooling capacity and efficiency. In extreme cases, the unit may fail to operate due to high refrigerant pressures inside the unit, and compressor and/or fan motor failure may occur. Clearances given in installation instructions ensure components can be serviced and maintenance can be performed when needed.

National and local electrical codes must be reviewed before unit installation.

Always use common sense when installing products, follow unit clearances given in the installation instructions and contact local Bard distributors when additional knowledge is needed regarding unit clearances for proper unit functionality.

WALL MOUNT Products – Clearances for Indoor Supply and Return Airflow

The Bard unit should be placed in an area where the supply (leaving conditioned air) and return (unit air intake) air paths will be unrestricted. Avoid placing objects in the structure within 24" of the return (unit air intake) grille. Avoid placing objects directly in the path of the supply (conditioned) air grille. This will inhibit the “throw” of the supply air throughout the structure and reduce the cooling and/or heating ability of the unit; in extreme cases, this may cause evaporator coil freezing issues. Supply air must be able to freely circulate conditioned air throughout the structure. Adjustment of supply grille deflectors is often necessary to ensure proper room circulation.

Ducted applications should not exceed the rated duct static pressures given in the unit specification sheets. Special requirements for duct construction and distances to combustible materials need to be followed per the installation instructions when electric heating is used.

WALL MOUNT Products – Condensate and Defrost Drainage

Condensate drainage for air conditioning units needs to be planned before installation. Your new Bard WALL MOUNT product includes provisions to allow condensate water to exit the bottom of the unit. If condensate water is to be routed away from the unit, adequate drain sizing needs to be provided to allow proper drainage for condensate water generation. During normal air conditioning operation, large amounts of condensate water is generated inside the unit as moisture is extracted from the supply air. This is collected in an evaporator pan and drained to either a drainage system (indoor products) or outside the unit cabinet (outdoor products). Evaporator drain traps are not necessary for any of our wall mounted outdoor products, and the use of “standing water” U-shaped traps may be prone to freezing in certain climate zones.

Defrost water drainage from heat pump units needs to be planned before installation. During seasons requiring heating operation, the unit will need to warm the condenser coil to remove frost build-up (defrost). **Outdoor heat pump products include holes in the unit base under the condenser coil for proper water drainage when in the heating defrost cycle. Avoid placing the unit on a pad or blocking the base drainage holes under the condenser coil without proper allowances (6" recommended) for water drainage due to damage caused by freezing conditions.** Without proper drainage, defrost water may freeze causing ice build up and damage the lower portion of the condenser coil.

Condensate Water Drainage:

Unit condensate water exits the base of the unit during cooling operation.



Defrost Water Drainage:

Holes are provided in the front of the unit base for heat pump condensate water drainage.

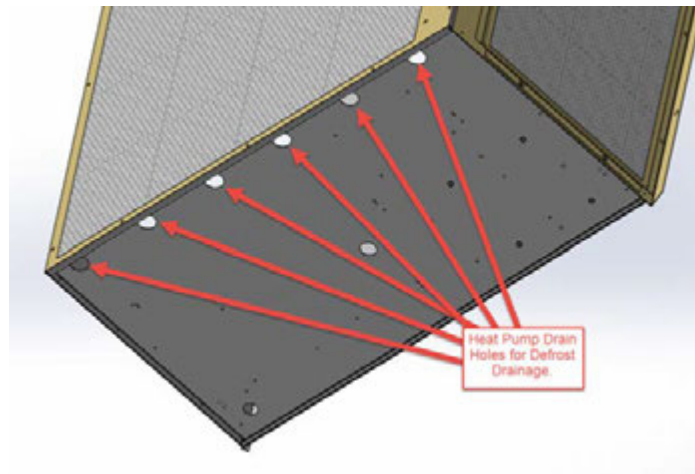

Defrost Water Drainage:

6" clearance is recommended under WALL MOUNT Heat Pump products to allow proper defrost water drainage.

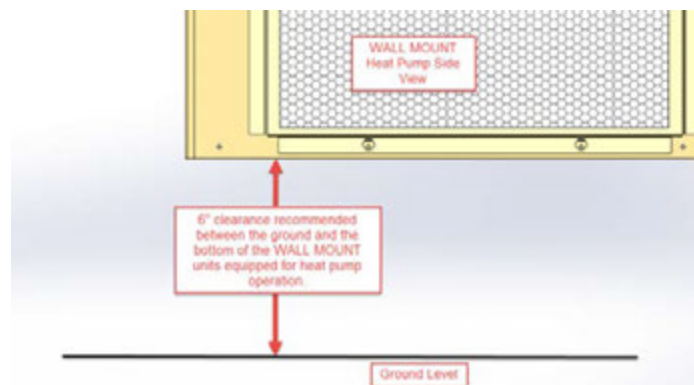

I-TEC and Q-TEC Products – Installing the Product Inside a Room



I-TEC



Q-TEC

Indoor products are normally supported by the floor surface and are adjacent to an interior wall surface, including brick, cement block, metal or wood construction. These products are normally labeled as “I-TEC” or “Q-TEC” units. **Before installation begins, the floor surface should be inspected by a construction professional to ensure it will support the weight of the unit and accessory items.** Approximate weights are available from the product specification sheet, and a safety factor should be designed into the installation.

A sheet metal sleeve is normally installed in the wall allowing vent and condenser fan air to enter and exit the unit. Different sleeve depths are available for installation into various wall depths. Typical fasteners to attach the sleeve to the outside surface of the wall include tap cons and other fastening devices. The I-TEC or Q-TEC unit is then slid up to the wall surface and connected to the sleeve using screws. Trim kits are available to enclose gaps between the wall surface and the unit. A louver grille is used to cover the external wall opening and fasteners used during sleeve installation.

Wall Sleeve:

Wall sleeves allow for outdoor air to enter and exit the unit inside the room.

Air Paths:

Air paths through the unit allow for cooling operation and fresh air to enter the structure (I-TEC shown).

Louver Installation:

Outdoor louvers provide an esthetically pleasing look to the installation and cover the unit opening (I-TEC shown).

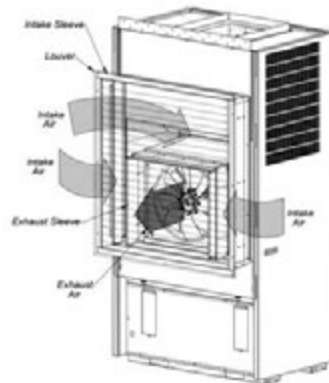
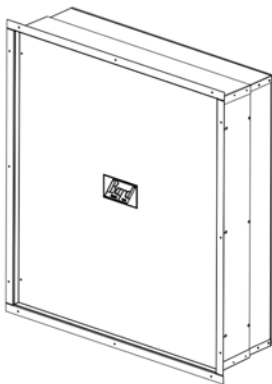

I-TEC and Q-TEC Products – Clearances for Outdoor Condenser Fan Airflow

Solid barriers located too close to the face of the outdoor louver of the I-TEC or Q-TEC can both impede airflow and force heated air to short circuit (be returned) from the condenser outlet to the condenser inlet. Either condition will effectively raise the condensing temperature and pressure reducing cooling capacity and efficiency. In extreme cases, the unit may fail to operate due to high refrigerant pressures inside the unit, and compressor and/or fan motor failure may occur. It is recommended to allow 15' (457.2 cm) in front of unit louver for proper condenser airflow. Always use common sense when installing products, follow unit clearances given in the installation instructions and contact local Bard distributors when additional knowledge is needed regarding unit clearances for proper unit functionality.

I-TEC and Q-TEC Products – Clearances for Indoor Supply and Return Airflow

The Bard unit should be placed in an area where the supply (leaving conditioned air) and return (unit air intake) air paths will be unrestricted. Avoid placing objects inside the room within 24" of the return (unit air intake) louvers or grille. Avoid placing objects directly in the path of the supply (conditioned) air grilles. This will inhibit the “throw” of the supply air throughout the structure and reduce the cooling and/or heating ability of the unit and in extreme cases may cause evaporator coil freezing issues. Ducted applications should not exceed the rated duct static pressures given in the unit specification sheets. Special requirements for duct construction and distances to combustible materials need to be followed per the unit installation instructions when electric heating is used.

I-TEC Air Path

The I-TEC product has been engineered for extremely quiet unit operation and has multiple air paths for air entering and exiting the unit. Room air enters the upper sides to be conditioned (cooled) inside the unit and exits the unit top. The unit will either be ducted to supply registers or have a supply air plenum box installed. A supply air plenum box allows quiet operation without ducting the air leaving the unit. Room air also enters the bottom of both front doors during ventilation operation.

Q-TEC Air Path

The Q-TEC product has been engineered for efficient, economical unit operation and has a mid-mounted front grille for air entering the unit. The unit will either be ducted to supply registers or have a supply air plenum box installed. A supply air plenum box allows quiet operation without ducting the air leaving the unit.

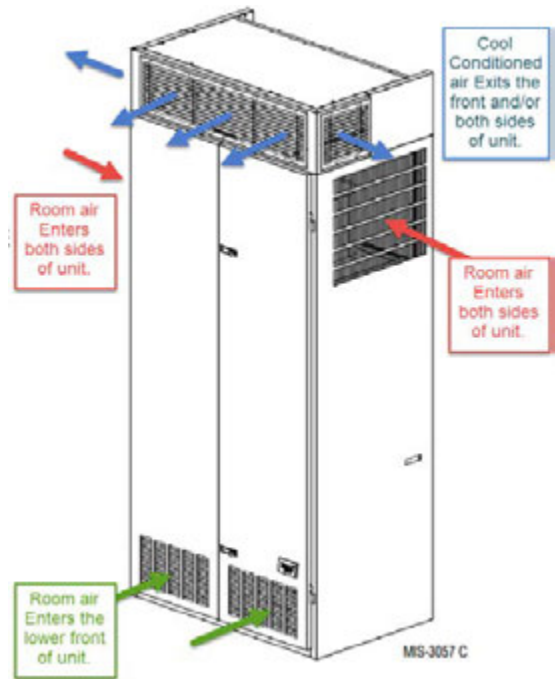

Typical I-TEC Installation

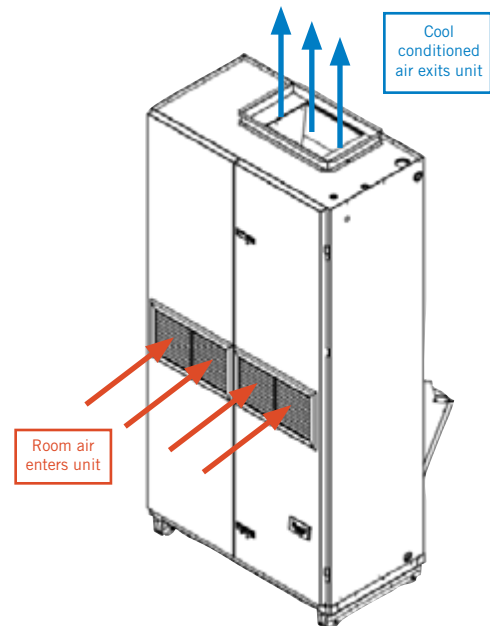

Typical Q-TEC Installation

The I-TEC and Q-TEC product installation instructions contain additional information regarding unit air paths and required clearances. This information may be accessed at www.bardhvac.com.

I-TEC and Q-TEC Products – Condensate Drainage

Condensate drainage for Bard indoor cooling units is a very important part of unit installation. During normal air conditioning operation, large amounts of condensate water are generated inside the unit as moisture is extracted from the supply air. This is collected in an evaporator pan and needs to be drained to an external drainage system. Your new Bard product includes provisions to allow condensate water to exit the unit and fittings will need to be field supplied to connect the unit drain to the building. Adequate drain sizing needs to be provided to allow proper drainage for condensate water generation and restriction in drain lines should be avoided. Evaporator drain traps are not necessary unless required by local codes.

Defrost water for heat pump operation and outdoor water entering the condenser area also needs to be drained out of the unit. The I-TEC product uses a combined defrost and outdoor water drainage system. The Q-TEC has a combined defrost and evaporator drain connection unless an optional in-wall drain box is used. Outdoor water exits the Q-TEC through the wall sleeve. Follow all instructions provided in the unit installation instructions regarding drain connections and sleeve installation to avoid water leakage inside the building or structure.

I-TEC Drain System:

The I-TEC drainage system consists of a manifold drain kit that combines all drains behind the unit to allow connection to the building system.

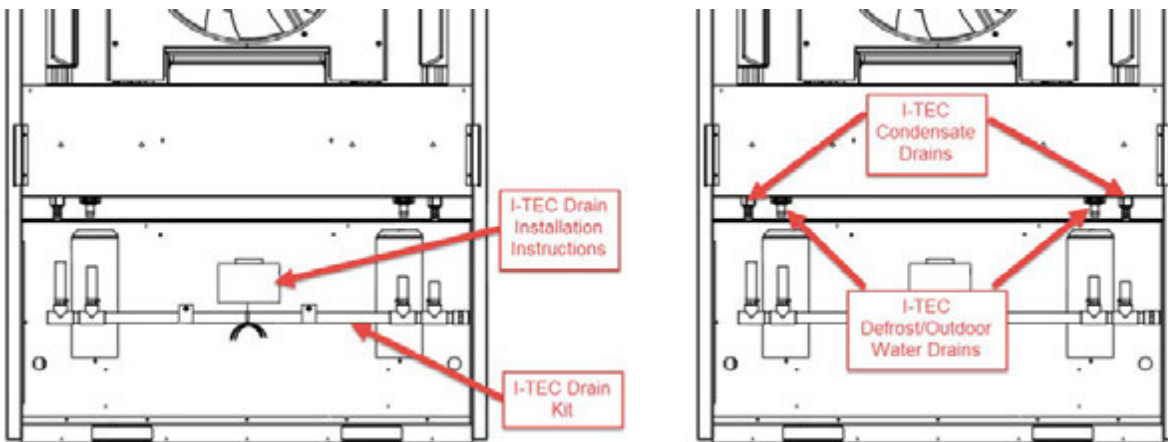

Q-TEC Drain System:

The Q-TEC drainage system consists of a lower right side or lower right rear connection fitting. An optional in-wall drain box may also be purchased as an accessory that allows separate evaporator and defrost water drainage.

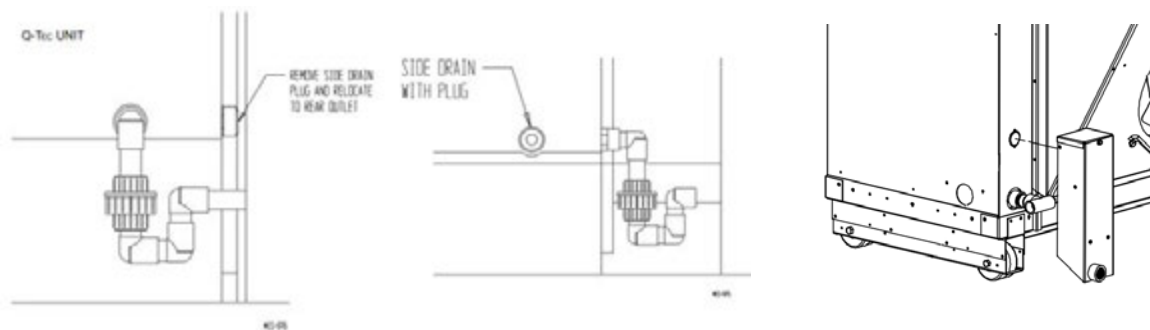

Lower Right Side Drain

Lower Right Rear Drain

Optional In-Wall Drain Box

All Products – Power Supply Verification

It is very important to follow all electrical and mechanical safety guidelines and instructions provided in the product installation instructions. Failure to do so may result in death, injury or product damage.

A proper power supply to your new Bard unit is very important. Be sure to verify the following with a multi-meter or other power measuring device before applying power to your Bard product.

Field-Supplied Voltage

Electrical voltage ratings and proper voltage operating ranges are provided in the unit specification sheets and installation instructions. It is important that power supplied to the unit stay in the specified operating voltage range. Voltage above or below the minimum operating value given could result in improper unit startup, unit shutdown, low unit performance, improper thermostat and unit controller operation, compressor damage and premature failure of functional parts. As a general guideline, it is always best if the power source for the unit supplies the nominal electrical rating value given in the specification sheets, installation instructions and unit serial plate for the product being used. To do so will provide the best unit performance possible from your new Bard product.

Single and Three Phase Power

Bard products are available in single and three phase power options. It is important to connect the proper phase listed on the unit serial plate. Three phase power is often used to reduce energy usage, and units rated for 3 phase operation are equipped with a phase monitor safety device. The phase monitor will not allow unit operation with improper phase connection and a red LED light on the monitor indicates phase wiring issues. Connecting 3 phase power to a single phase unit will result in component damage and improper unit operation. Connecting single phase power to a 3 phase unit will also result in component damage and improper unit operation.

Hertz (Frequency)

Bard products are available in 50hz and 60hz power options. It is important to connect power with the proper hz value listed on the unit serial plate. 60hz power is often used in the United States and Canada and units rated for 50hz operation are normally for international sales outside of this area. Connecting 50hz power to a 60hz unit not rated for 50hz operation may result in component damage and improper unit operation. Some equipment may be rated for 50/60hz operation. Review the unit specifications and installation instructions for further information regarding the power requirements of the unit.

The product installation instructions and unit specification sheets contain additional information regarding unit electrical data. This information may be accessed at www.bardhvac.com.

Unit Maintenance

All Products – Filters and Filter Servicing

All Bard products contain air filters that must be cleaned or replaced on a regular basis.

Keeping air filter(s) clean is the single most important responsibility of the user of the equipment. Each type of system must be equipped with an air filter(s) in the indoor circulating air system to clean the air, keep the system itself clean for peak efficiency and capacity and prolong the useful life of the equipment. DO NOT operate the system without the proper air filters. Filters should be inspected at least monthly and replaced or cleaned (depending on type) as needed. The useful life of an air filter can vary widely depending upon application and use of the equipment, and it is critical to monitor filter condition and establish an acceptable maintenance schedule. Failure to do so will increase operating and repair costs, decrease capacity and efficiency and shorten the service life of the equipment. A common symptom of a dirty filter in the cooling mode is a freeze-up of the indoor coil. The air filters used may be a disposable (throwaway) type or may be a cleanable type that can be thoroughly cleaned, rinsed and reused many times. It is important to make sure that the correct filter size and type for your system is always used. If there is any question as to acceptable filter size or type, review the installation instructions for the specific equipment involved, if available. Otherwise, consult with your installing dealer or service company. Most equipment can have the filters inspected and serviced by the user with no problems. In some instances, because of equipment design or specific installation conditions, it may be necessary to have this procedure done by a qualified service company. Have your installer or service company show you where the filter(s) are and demonstrate the service procedure or make arrangements for them to provide this service on an as-needed basis.

Outdoor Unit Wall Mount Room Air Filters

Wall mount filters are normally accessed from the outside of the building. Bard does offer a return air grille with a filter frame built-in for indoor filter access. The return air filter grille is not acceptable as the only source of filtration if vent options are installed in the wall mount unit.

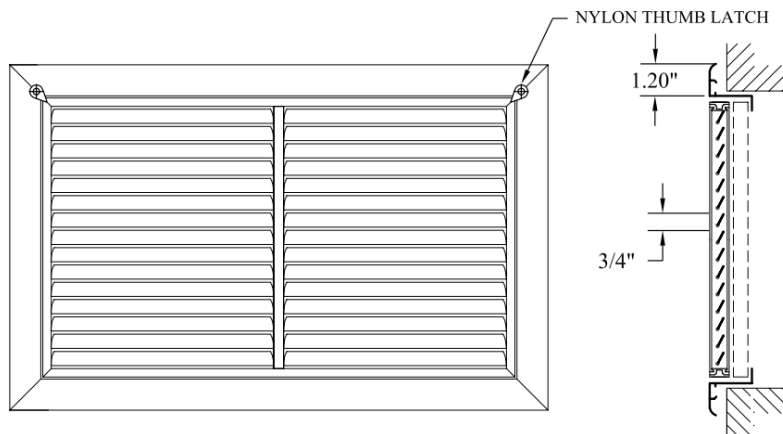

Return Air Filter Grille:

Bard offers the RFG return air filter grille, which may be used in applications where outdoor air is not brought into the structure through vent options. If vent options are used, the filter tray inside the Bard Wall Mount unit must be used.

The product installation instructions contain additional information regarding unit maintenance. This information may be accessed at www.bardhvac.com.

WALL MOUNT Products – Filters and Filter Servicing

The built-in filter tray and room air filters in the wall mount are located in the middle of the cabinet below the indoor blowers. Units with vent options will have a washable screen behind the vent intake panel.



Filter Door:

The unit room air filter is located behind this panel for units without a vent hood.

Vent Intake Panel

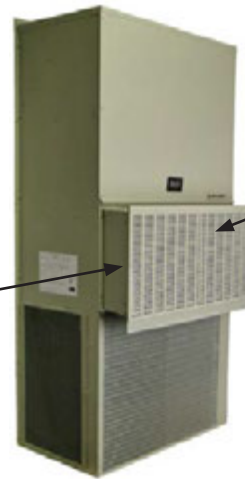

Vent Intake Panel

Vent Hood Door:

The unit indoor filter is located behind this panel for units with a vent hood. The hood contains a washable pre-filter that needs to be cleaned regularly.

Filter Door:
The unit room air filter is located behind this panel.



I-TEC Indoor Products – Filters and Filter Servicing

The I-TEC indoor air conditioners and heat pumps have multiple filters that must be maintained and inspected when servicing the unit. Filters play an important part in proper unit operation and prevent dirt and dust buildup inside the I-TEC and the room the unit is installed in. To access the unit filters, open the front hinged doors by unlocking the door latches. The doors fold outward and are on hinges with lift-off pins. Use care when opening doors. If doors are lifted off of the hinge pins, use care as the dense insulation used for sound reduction causes the doors to be heavy.

The upper section of the unit contains two 2" x 24" x 30" throwaway filters as standard with every unit. MERV ratings of the filter are available up to MERV13. These filters filter the air used for cooling inside the classroom or structure and should be changed regularly.

If the unit has an air intake vent option installed, two 1" x 12" x 20" filters are located in the lower section of the front doors behind the louvers. These filters help keep the vent option clean and operating properly.

Two washable filters are also installed in the air intake vent option. These should be inspected during servicing and cleaned when necessary. The washable filters are used to remove dirt and dust from outdoor air that is entering the vent area. If at any time these filters are damaged, they must be replaced with Bard-approved filters.

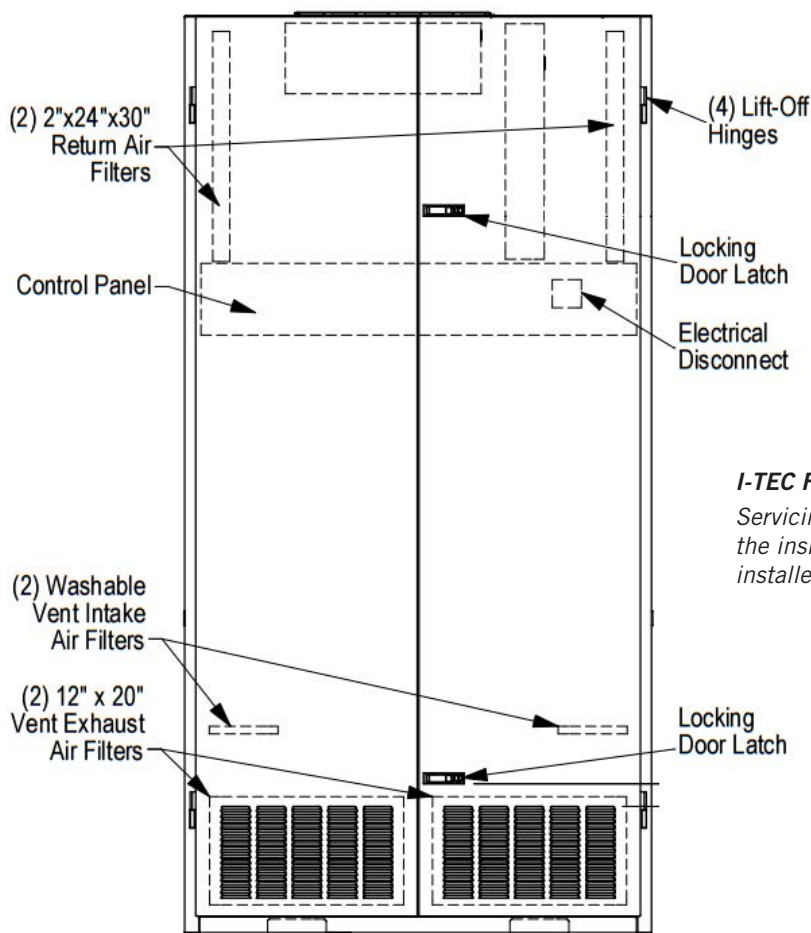

I-TEC Filter Locations:

Servicing the filters in your unit will help keep the inside of the unit clean and also the area it is installed in.

The I-TEC product installation instructions contain additional information regarding unit maintenance. This information may be accessed at www.bardhvac.com.

Q-TEC Indoor Products – Filters and Filter Servicing

The Q-TEC indoor air conditioners and heat pumps have two room air filters that must be replaced when servicing the unit. Filters play an important part in proper unit operation and prevent dirt and dust buildup inside the Q-TEC and the room the unit is installed in. To access the unit filters, open the front hinged door by unlocking the door latch. The door folds outward and is on hinges with lift-off pins. Use care when opening doors. If the door is lifted off of the hinge pins, use care as the insulation and louver grille cause the door to be heavy.

The upper section of the Q-TEC contains two 1" throwaway filters standard with every unit. These filters filter the air used for cooling inside the classroom or structure and should be changed regularly.

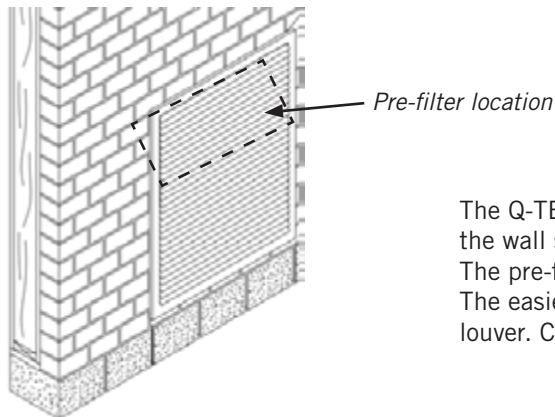
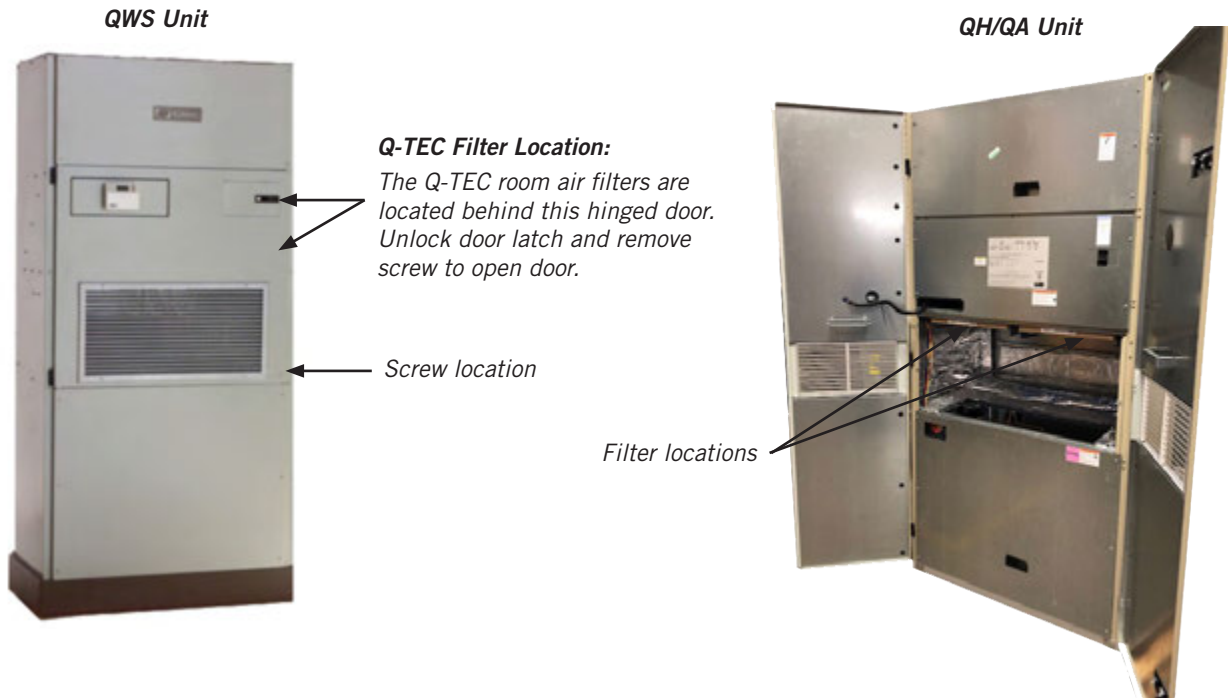

The Q-TEC will have a permanent pre-filter installed inside the wall sleeve if air intake vent options are inside the unit. The pre-filter must be inspected and cleaned when necessary. The easiest way to remove the pre-filter is through the outdoor louver. Clean the pre-filter with soapy water.

The Q-TEC product installation instructions contain additional information regarding unit maintenance. This information may be accessed at www.bardhvac.com.

All Products – Coil Cleaning

The outdoor coil must be kept clean and free of any airborne debris, which can accumulate over time. Large volumes of air are circulated over the coil, and airborne debris such as lint, dust, materials shed from trees, paper or other types of airborne material that can become airborne can collect on the entering coil surface. The outdoor coil must dissipate heat during the cooling mode and for a heat pump, also absorb heat during the heating mode. If the coil is dirty and matted with debris, the airflow across the coil will be reduced causing poor performance, increased operating run time and associated utility bills and in extreme conditions can shorten the useful life of the equipment.

Depending on the specific equipment involved, the surface that can accumulate debris can be on the opposite side that is exposed to view when standing in front of the machine. Closely review the machine when operating to see which direction or path the airflow takes as it moves through the machine. If the air inlet side of the coil is hidden, try to observe the back (hidden) side by looking into the side grilles, using a flashlight if necessary. While the user of the equipment needs to be aware of the potential of clogging of the outdoor coil surface, actual cleaning of the outdoor coil should not be attempted under most circumstances. If the user should attempt this procedure on their own, never do so without first having the installing dealer or service company instruct you in the proper procedure and technique.

WARNING: Do not open or enter the equipment without first turning off the electrical service disconnect. Failure to do so can result in personal injury due to moving parts and/or electric shock hazard resulting in death.

Other conditions that can cause reduction of airflow across the outdoor coil are flowers, shrubbery or other growth too near the outdoor coil air inlet and outlet openings. These living things, especially as they mature and grow, will be just as effective in blocking the airflow and create the same problems as will stacking things against the equipment. These conditions can be easily managed and controlled by the user, as they do not require actually entering into the equipment enclosure, which should only be done by qualified service technicians.

Equipment Corrosion Protection

1. Avoid having any lawn sprinkler spray directly on the equipment, especially if from a brackish water source.
2. In coastal areas or corrosive environments, locate equipment as far away from the corrosion source as feasible. Units exposed directly to salt spray should be coated by a secondary protective coating operation to reduce corrosion on copper tubing, fasteners, motors and other metal parts. Coils should be ordered with a corrosion protective coating. Contact Bard for coating options.
3. Frequent cleaning and waxing of the cabinet using a good automobile polish will help extend its original appearance and protect painted surfaces.

The product installation instructions contain additional information regarding unit coil cleaning. This information may be accessed at www.bardhvac.com.

All Products – Condenser Airflow

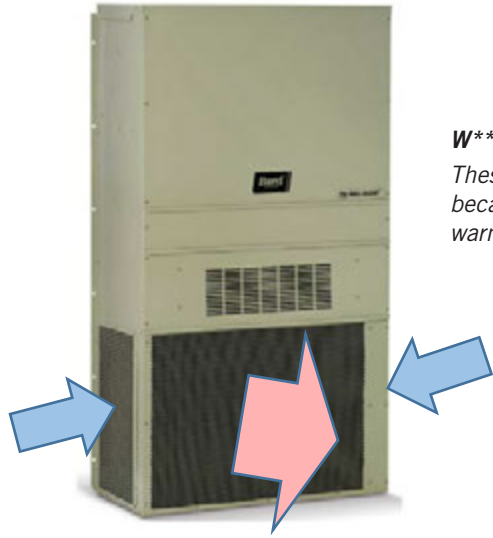

WA, W**H, T**H, T**S, W*RV Wall Mount Units:**

These units are called “blow through condenser airflow” units because they draw cool outdoor air from the sides and blow the warm condenser air exiting the coil through the front grille.

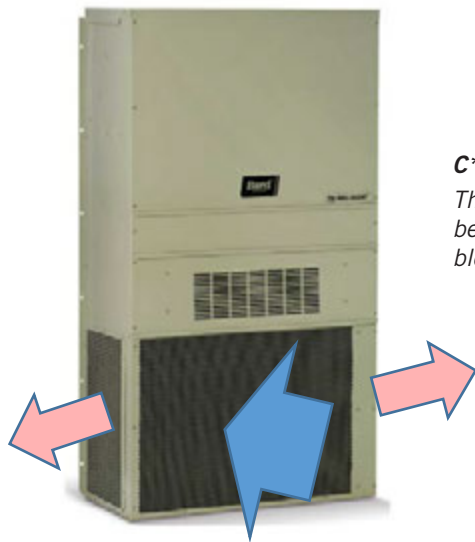

CH Wall Mount Units:**

These units are called “draw through condenser airflow” units because they draw cool outdoor air in the front through the coil and blow the exiting warm condenser air through the unit sides.

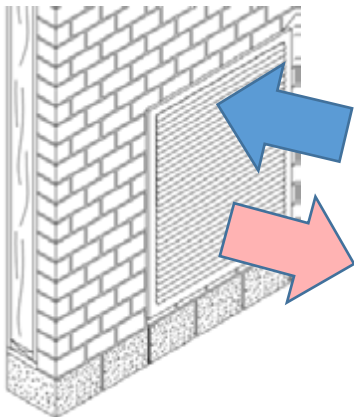

I-TEC and Q-TEC Units:

These units draw the cool outdoor air through the top section of the wall louver and exhaust the warmer condenser air out of the lower section of the louver. I-TEC units also draw a small amount of air through the outer right and left side of the louver.

Unit Operation

Air-to-Air Cooling Products (Air Conditioners)

The cooling mode operates similar to a refrigerator, removing heat from inside the conditioned space and rejecting it outside of the space being controlled. There are three main parts of the system:

1. The evaporator (indoor) coil where cold refrigerant absorbs heat from the air, which circulates from the conditioned space through the machine and is returned to the space at a lower temperature and with some of the humidity (moisture) removed. The moisture exits through a condensate drain system. A motor/blower assembly moves the indoor air through the system.
2. The compressor, which is a sealed pump that moves the refrigerant through the system.
3. The condenser (outdoor) coil where the heat that was absorbed from the indoor space is discharged to the outdoor environment. A motor/fan system moves the outdoor air across the condenser coil. A properly sized air conditioner cannot cool a structure off rapidly and instead will pull down the temperature slowly. It also will remove a certain amount of moisture (humidity) from the circulating airstream in the process. It may take several hours to pull down a hot, moist building or structure on initial startup or anytime the system has been turned off for a long period of time. It is generally best to set the thermostat at a comfortable temperature and let it control the system as needed, rather than turning it on and off.

Moisture (humidity) removal with a conventional air conditioner (cooling) unit, or heat pump when operating in the cooling mode, is not directly controlled and is a by-product of the unit operating to control temperature in response to the temperature (thermostat) control device. **Oversized equipment can easily control temperature but will have short run-times, thus reducing its ability to remove moisture from the circulating air stream.**

There are also many additional influences that can affect humidity levels within the conditioned space such as laundry appliances, cooking, showers, exhaust fans and any other items that can generate moisture or affect its removal from the space. Therefore, while operation of the air conditioning or heat pump system in the cooling mode will remove some amount of moisture as it reduces the air temperature, precise humidity regulation in the conditioned space cannot be assured and additional equipment such as a dedicated dehumidifier may be required.

Air-to-Air Cooling and Heating Products (Heat Pumps)

A heat pump is a refrigerant-based system that has additional components and controls that both heats and cools using a compressor for both modes of operation. Most heat pumps will also be equipped with some amount of electric heat to supplement the heating capacity of the compressor system on an as-needed basis. This operation is entirely automatic and is controlled by the indoor thermostat and possibly also an outdoor thermostat.

Cooling Mode

The cooling mode of a heat pump is exactly the same as that described for an air conditioner in the above section.

Heating Mode

The system operates in reverse cycle, meaning that it absorbs and moves heat from the outdoors and transfers it indoors to be rejected into the circulating air stream. Even though it seems cold to humans, there is usable heat that can be extracted efficiently from the outdoor air down to 0°F, although the colder the air is there is less heat to extract and the operating efficiency is diminished.

Defrost Cycle

When operating in the heating mode, the outdoor coil will be colder than the outdoor air that is forced over it by the fan system. When the outdoor air temperature is above approximately 40°F, moisture can accumulate on the coil and it will drain down and out the base of the unit. As the air temperature gets below approximately 40°F, the coil temperature will start to drop below 32°F, and frost or ice will begin to form on the coil.

An automatic defrost system keeps track of system run time when the outdoor coil temperature is in the freezing zone and will initiate a defrost cycle at the appropriate time. The unit continues to operate during the defrost cycle, but the outdoor fan motor will stop and the reversing valve will shift positions to flow hot refrigerant gas through the outdoor coil to melt the accumulated frost. Water will start to drain freely from the unit, and steam may be emitted from the unit.

The length of the defrost cycle will vary depending upon actual outdoor temperature, humidity levels and amount of accumulated frost. It could range from 1-2 minutes up to but not exceeding 8 minutes. When the defrost cycle

terminates, the reversing valve will shift back to heating mode and the outdoor fan will restart. There is typically a large puff of steam emitted as the fan restarts. When the heat pump shifts from cool to heating mode, from heating to cooling mode and especially during defrost cycles, there will be a pressure transfer sound heard as the reversing valve redirects the flow of refrigerant. This is commonly described as a hissing noise and is a normal sound for this type equipment.

For air source heat pumps, it is important to keep heavy snow from accumulating around the machine to the point of blocking the inlet and outlet openings to the outdoor coil section. For wall mounted or other equipment that is elevated, this should not be a factor; but for equipment installed on or near the ground, this can be an issue in areas prone to heavy and/or blowing snow. The air source heat pump cannot operate effectively and efficiently when snowbound just as a car cannot function well in heavy snow conditions.

Water-to-Air Cooling and Heating Products (Geothermal Heat Pumps)

These types of heat pumps are also commonly referred to as water source or geothermal systems. Just like the air source heat pump, they are refrigerant-based systems that both heat and cool using a compressor for both modes of operation. The primary difference is that the system uses water or antifreeze-protected water solution instead of an air-cooled outdoor heat transfer coil, and there is no outdoor motor/fan system but instead a water pump to provide adequate water flow to the system.

Cooling Mode

The cooling mode of a water-to-air heat pump is exactly the same as that described for an air conditioner in the previous Air Conditioner section, except that the outdoor coil uses water instead of air for the heat transfer medium.

Heat Mode

The system operates in reverse cycle, meaning that it acquires and moves heat from the water supply flowing through the water to refrigerant coil and transfers it indoors to be rejected into the circulating air stream.

Most water-to-air heat pumps (but not all) will also be equipped with some amount of electric heat to supplement the heating capacity of the compressor system on an as-needed basis. This operation is entirely automatic and is controlled by the indoor thermostat.

Because of the design of water-to-air heat pumps and the water temperatures involved, no defrost system is required as in air-to-air heat pumps.

Water Supply Systems

Depending upon the type and application of the water-to-air heat pump, the water side of the system could be one of the following:

1. Individual closed loop buried in a trench or vertical bore hole(s).
2. Individual loop submerged in a pond.
3. Water supplied from a well and discharged into pond, stream, ditch or another well.
4. Water supplied from a boiler/tower system, typically only in larger multi-unit installations.

Dehumidification and Ventilation Operation

Dehumidification (Air-to-Air or Water-to-Air Systems)

Many Bard systems, typically those used in schools or other commercial applications, have a dedicated dehumidification capability by having a special additional refrigeration circuit (factory-installed option only) in addition to the basic system. These special systems, sometimes also referred to as hot gas reheat, are designed to control humidity on demand from a humidity controller much the same as the basic cooling and/or heating system is controlled by a wall thermostat. Consult your installer and/or service company to determine if your installation has any of these devices and for any instructions or maintenance requirements you should be aware of as the user.

Ventilation Options (Air-to-Air or Water-to-Air Systems)

All Bard systems are available with factory-installed vent options. Most units can have ventilation field installed after unit installation.

Ventilation has multiple purposes:

- Outside air intake for occupied structures
- Positive pressurization
- Energy savings when outdoor air can be used for cooling
- Agricultural use of bringing in outdoor air and exhausting room air
- Equipment and electronics ventilation

Review product specifications and manuals for more details regarding available ventilation options and features. Product documentation is shipped with the product and also available at www.bardhvac.com.

All Units – Troubleshooting

Your Bard product is made to operate for many trouble-free years if installed properly and maintenance practices are followed. Be sure to verify that all filters are clean, and condenser coils are free of dirt and debris. Often these items may look clean at first, but upon closer inspection, show signs of dirt and debris build-up. New units on new structures may have dirt and dust in filters from the building construction process.

Thermostats and unit controllers often contain vent holes for proper sensor measurement inside the device. Make sure the thermostat or controller are not full of dirt and dust from building construction or years of use.

Verify all requirements in the installation instructions and specification sheets are met. Unit voltages, airflow clearance requirements and clean unit power without brownouts or spikes play a critical role in unit performance. If 208 VAC power is supplied to the unit, the 208V tap must be used on the 24 VAC transformer located inside the control panel. Common sense must also be used when installing the unit in an environment that may put the unit at risk of improper operation.

Helpful Hints and Good Operating Practices

The following information will help you enjoy the full comfort and benefits of your Bard cooling and heating system, maximize the performance and efficiency and help extend the life of your system.

1. Always keep the equipment in peak operating condition with routine scheduled maintenance, especially for the air filters, and to assure a clean outdoor coil.
2. For most efficient operation, set the thermostat at the temperature you prefer and then let it take control. If any changes to the settings are required, they should be made in small adjustments and the system be allowed time to respond. Rapid changes either up or down should not be done.
3. Setting the thermostat very high does not make the system heat faster and setting it very low does not make it cool faster.
4. It is not recommended to turn the system "Off" then back "On" when you need it. This can allow temperature and humidity to build up in warm weather conditions and force the system to run continuously to try and catch up. If the building is to be unoccupied for a lengthy period, it is best to adjust the thermostat to a reasonable higher (or lower—depending on the season) setting rather than turning it completely off. Upon return, the inside conditions will not be totally out of control and recovery time to desired conditions would be much shorter.
5. Airflow inside the room or building is very important. Keep all supply registers open and all returns free and unrestricted. Avoid placing objects in areas that will hinder unit airflow. The heating and cooling system is designed to have a certain amount of airflow for proper operation. Therefore, closing off registers, in unused rooms as an example, could reduce airflow below acceptable levels and should not be done without review by your service company who can assess the overall situation and advise you accordingly.
6. Heat pumps, especially air-to-air heat pumps, may have the system (compressor) run continuously at lower outdoor temperatures, and this is normal. The heat pump (compressor) mode is controlled by the beginning stages of the thermostat and delivers the most efficient heat. As the outdoor temperature drops off, the heat pump mode heat will also diminish (because there is less heat in the outdoor air to absorb) and must be supplemented by additional electric heat stages, which are not as efficient as the heat pump. The thermostat automatically controls everything and the backup heat will only operate on demand as needed to maintain the desired temperature.
7. The thermostat or controller is the user's primary connection to the system so it is very important to have a thorough understanding of how it works and how to use it properly. Have your installer or service company explain and demonstrate proper operation of the controls.
8. Make sure you thoroughly understand how the heating and cooling system itself is intended to operate and what to expect from it. Have your installer or service company explain and demonstrate proper operation of the heating and cooling system.

A2L REFRIGERANT SAFETY, SERVICE AND DECOMMISSIONING MANUAL

Models:

All Bard Models Using R-454B Refrigerant



IMPORTANT NOTE:

Read this manual carefully before installing, operating or servicing the new air conditioning unit. Make sure to save this manual for future reference.



CAUTION:
Risk of Fire

Refrigerant
Safety Group
A2L



Bard Manufacturing Company, Inc.
Bryan, Ohio 43506
www.bardhvac.com

Manual: 2100-810
Supersedes: **NEW**
Date: 10-16-24

CONTENTS

Safety Precautions	3
Servicing Safety Information.....	11
Explanation of Symbols Displayed on the Unit.....	14
Refrigerant Leak Detection System (RDS)	15
Servicing Procedures	16
Recovery Equipment Rated for R-454B Refrigerant.....	16
Leak Detectors	16
Gauge Manifold	16
Attaching Gauge Manifold	16
Leak Test	16
Evacuation.....	17
R-454B System Charging.....	17
Preliminary Charging Steps.....	18
Charging the System by Weight.....	18
EEV Instructions for Recovering, Evacuating and Charging the Unit.....	18
Troubleshooting the Mechanical System.....	24
Air Conditioning and Heat Pump – Cooling	24
Low Suction – Low Head Pressure	24
High Suction – Low Head Pressure	24
Low Suction – High Head Pressure	24
High Suction – High Head Pressure	24
Heat Pump – Heating	24
Low Suction – Low Head Pressure	24
High Suction – Low Head Pressure	24
Low Suction – High Head Pressure	24
High Suction – High Head Pressure	24
Troubleshooting Chart for Air Conditioners.....	25
Troubleshooting Chart for Heat Pumps	26

Figures

Figure 1	Release Height, Release Offset and Installed Height in Common Bard Unit Installations.....	5
Figure 2	Electronic Expansion Valve (EEV) and Service Tool.....	18
Figure 3	Typical Air Conditioning System Cooling Cycle	19
Figure 4	Typical Heat Pump System Cooling Cycle	20
Figure 5	Heating Cycle	21
Figure 6	Air Conditioning Mode Circuit Diagram...	22
Figure 7	Dehumidification Mode Circuit Diagram ...	23

Tables

Table 1A	Maximum Allowable Charge in Kilograms..	6
Table 1B	Maximum Allowable Charge in Ounces	6
Table 2A	Minimum Room Area in m ²	7
Table 2B	Minimum Room Area in ft ²	7
Table 3A	Minimum Airflow in m ³ /h	8
Table 3B	Minimum Airflow in CFM	8
Table 4A	Maximum Charge in Kilograms	8
Table 4B	Maximum Charge in Ounces.....	8
Table 5A	Minimum Total Room Area in m ²	9
Table 5B	Minimum Total Room Area in ft ²	9
Table 6A	Example Altitude Adjustment Factors (AF) and Use Example (m)	10
Table 6B	Example Altitude Adjustment Factors (AF) and Use Example (ft).....	10

The design and specifications are subject to change without prior notice for product improvement. Consult with the sales agency or manufacturer for details. Any updates to the manual will be uploaded to the Bard website, please check for the latest version.

WARNING

Read safety precautions before operation and installation.

Incorrect installation due to ignoring instructions can cause serious damage or injury.

The section below provides requirements, warnings, and information regarding best practices for safe and proper installation, service and storage of Bard R-454B equipment. Please adhere to all requirements and recommendations.

1. Installation

- Bard wall mount air conditioners are classified as SPVUs (single package vertical units). All refrigerant piping is contained within the unit and all units are shipped with a factory refrigerant charge. No field joints are required for installation. However, care should be taken not to damage pipe work during installation.
- In cases where the installation space requires mechanical ventilation, ensure that ventilation openings are kept clear of obstructions.

2. Servicing

- Any person who is involved with working on a unit or breaking into a refrigerant circuit should hold a current valid certificate from an industry-accredited assessment authority, which authorizes their competence to handle refrigerants safely in accordance with an industry recognized assessment specification. Certification examples include: EPA 608 Certification and/or ACCA A2L Training and Certification classes.
- Examples for such working procedures are:
 - Breaking into the refrigerating circuit
 - Opening of sealed components
 - Opening of ventilated enclosures

3. Maintenance and repair requiring the assistance of other skilled personnel shall be carried out under the supervision of the person competent in the use of flammable refrigerants.

4. Do not use means to accelerate the defrosting process or to clean, other than those recommended by Bard. See most recent version of User's Guide 2100-034 for more information.

5. The appliance shall be stored in a room without continuously operating ignition sources (for example: Open flames, an operating gas appliance or an operating electric heater).
6. Be careful that foreign matter (oil, water, etc) does not enter the piping. Also, when storing piping or components for service replacement, securely seal all openings by pinching, taping, etc.
7. Do not pierce or burn copper or refrigerant-containing components.
8. Be aware that refrigerants may not contain an odor.
9. Work procedures shall only be carried out by competent persons.
10. Appliance shall be stored in well-ventilated area where room size corresponds to the room area as specified for operation. Appliances stored in unventilated areas shall comply with the information found on page 9.
11. The appliance shall be stored so as to prevent mechanical damage from occurring.
12. All field joints shall be tested with detection equipment with a capability of 5 g/year of refrigerant or better, with the equipment in standstill and under operation or under a pressure of at least these standstill or operation conditions after installation. Detachable joints shall NOT be used in the indoor side of the unit (brazed, welded joint could be used).
13. When a FLAMMABLE REFRIGERANT is used, the requirements for installation space of appliance and/or ventilation requirements are determined according to:
 - The mass charge amount (M_c) used in the appliance
 - The installation location
 - The type of ventilation of the location or of the appliance

The maximum charge in a room shall be in accordance with the following:

- $M_{max} = 0.5 \times LFL \times h_0 \times A$

or the required minimum floor area A_{min} to install an appliance with refrigerant charge M_c (kg) shall be in accordance with:

- $A_{min} = M_c / (0.5 \times LFL \times h_0)$

Where

M_{max} is the allowable maximum charge in a room, in kg

M_c is the refrigerant charge amount in appliance, in kg

A_{min} is the required minimum room area, in m^2

A is the room area, in m^2

LFL is the lower flammable limit, in kg/m^3 . For R-454B at worst case formulation, this value is $0.296 kg/m^3$.

h_0 is the release height, the vertical distance in meters from the floor to the lowest point of release when the appliance is installed.

$h_0 = (h_{inst} + h_{rel})$ or 0.6m, whichever is higher

h_{rel} is the release offset in meters from the bottom of the appliance to the point of the release

h_{inst} is the installed height in meters of the unit

For appliances serving one or more rooms with an air duct system, the lowest opening of the duct connection to each conditioned space or any opening of the indoor unit greater than $5 cm^2$, at the lowest position to the space, shall be used for h_0 . However, h_0 shall not be less than 0.6 m. A_{min} shall be calculated as a function of the opening. See Figure 1 for examples of h_0 , h_{rel} and h_{inst} as applied to common installations of Bard units.

NOTE: The unit charge (M_c) is listed on the unit serial plate. This can be used to calculate A_{min} .

FIGURE 1
Release Height, Release Offset and Installed Height in Common Installations of Bard Units

**BARD WALL MOUNT
 OUTDOOR UNIT-
 NON-DUCTED**

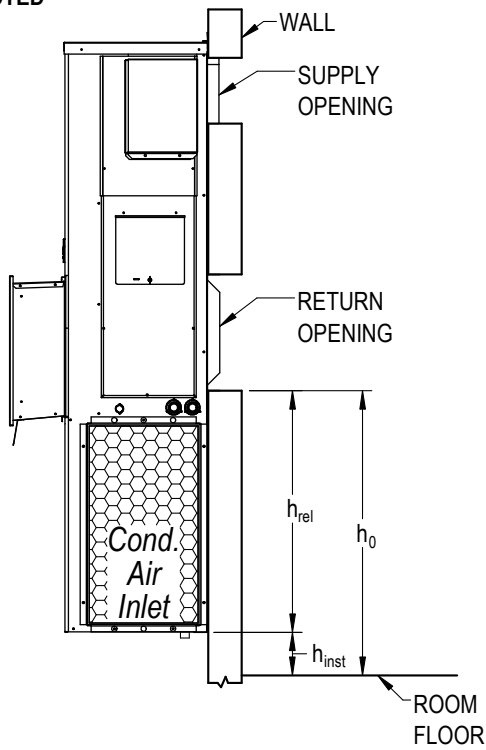

**BARD I-TEC
 INDOOR UNIT**

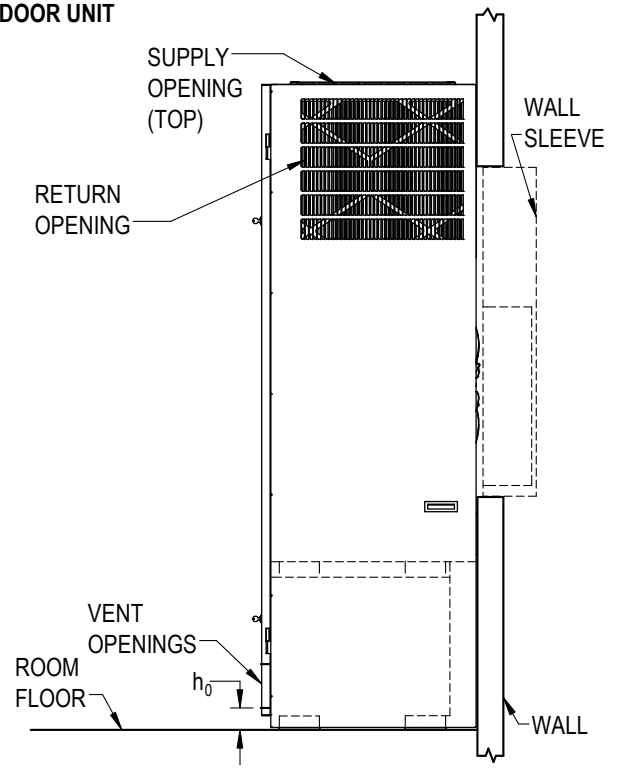

**BARD WALL MOUNT
 OUTDOOR UNIT-
 DUCTED**

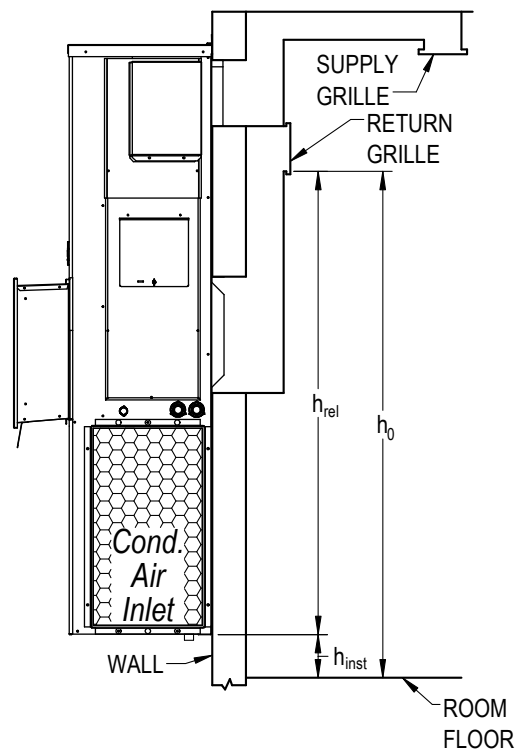

**BARD WALL MOUNT
 OUTDOOR UNIT-
 DUCTED**

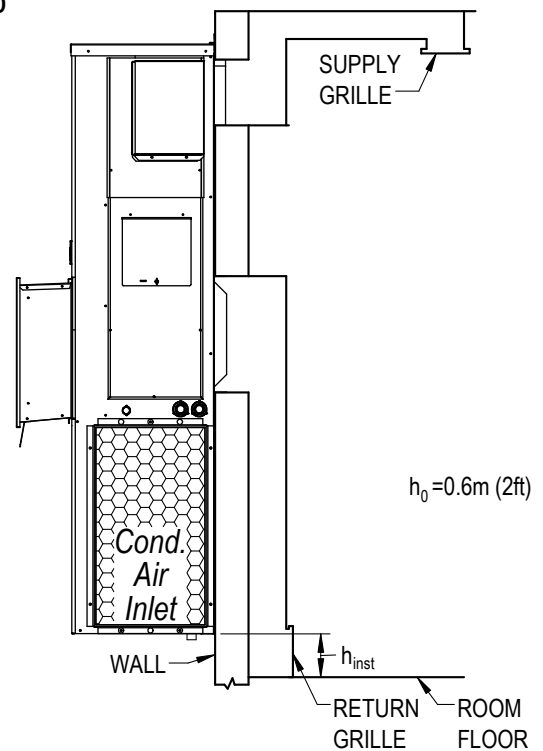

MIS-4523

TABLE 1A
Maximum Allowable Charge (M_{max}) in Kilograms

Release Height h_0 (m)	Room Area (m ²)									
	10	20	30	40	50	60	70	80	90	100
0.6	1	2	3	4	4	5	6	7	8	9
1.0	1	3	4	6	7	9	10	12	13	15
1.5	2	4	7	9	11	13	16	18	20	22
2.0	3	6	9	12	15	18	21	24	27	30
2.5	4	7	11	15	19	22	26	30	33	37
3.0	4	9	13	18	22	27	31	36	40	44

NOTE: Values are based on a non-ventilated room at sea level.

TABLE 1B
Maximum Allowable Charge (M_{max}) in Ounces

Release Height h_0 (ft)	Room Area (ft ²)									
	100	200	300	400	500	600	700	800	900	1000
2	30	59	89	118	148	177	207	237	266	296
3	44	89	133	177	222	266	310	355	399	443
4	59	118	177	237	296	355	414	473	532	591
5	74	148	222	296	370	443	517	591	665	739
6	89	177	266	355	443	532	621	710	798	887
7	103	207	310	414	517	621	724	828	931	1035
8	118	237	355	473	591	710	828	946	1064	1183
9	133	266	399	532	665	798	931	1064	1197	1330
10	148	296	443	591	739	887	1035	1183	1330	1478

NOTE: Values are based on a non-ventilated room at sea level.

TABLE 2A
Minimum Room Area (A_{min}) in m^2

Release Height h_0 (m)	Mc (kg)										
	0.5	1.0	1.5	2.0	2.5	3.0	3.5	4.0	4.5	5.0	5.5
0.6	6	11	17	23	28	34	39	45	51	56	62
1.0	3	7	10	14	17	20	24	27	30	34	37
1.5	2	5	7	9	11	14	16	18	20	23	25
2.0	2	3	5	7	8	10	12	14	15	17	19
2.5	1	3	4	5	7	8	9	11	12	14	15
3.0	1	2	3	5	6	7	8	9	10	11	12

NOTE: Values are based on a non-ventilated room at sea level.

TABLE 2B
Minimum Room Area (A_{min}) in ft^2

Release Height h_0 (ft)	Mc (oz)									
	40	60	80	100	120	140	160	180	200	
2	135	203	271	338	406	474	541	609	676	
3	90	135	180	225	271	316	361	406	451	
4	68	101	135	169	203	237	271	304	338	
5	54	81	108	135	162	189	216	244	271	
6	45	68	90	113	135	158	180	203	225	
7	39	58	77	97	116	135	155	174	193	
8	34	51	68	85	101	118	135	152	169	
9	30	45	60	75	90	105	120	135	150	
10	27	41	54	68	81	95	108	122	135	

NOTE: Values are based on a non-ventilated room at sea level.

In cases where appliances are connected to one or more rooms via an air duct system and directly ducted to the space, M_{max} may be reduced or A_{min} may be increased. In these cases, M_{max} shall be determined based on the total area of the conditioned space (TA) connected by ducts, taking into consideration that the circulation airflow distributed to all the rooms by the appliance's integral indoor fan will mix and dilute the leaking refrigerant before entering any room. Note that in spaces where the airflow may be limited by zoning dampers, the Refrigerant Leak Detection

System (RDS) shall open the zoning dampers when in alarm state (see unit installation manual for RDS alarm output connection information).

For appliances connected to one or more rooms via an air duct system, the minimum airflow for compliance may be determined using the equation below. See Tables 3A and 3B for reference values.

$$Q_{min} = 30 \times M_c / LFL$$

Where Q_{min} is the minimum circulation airflow circulated to the total conditioned space in m^3/h .

TABLE 3A
Minimum Airflow (Q_{min}) in m^3/h

Mc (kg)	Q_{min} (m^3/h)										
	0.5	1.0	1.5	2.0	2.5	3.0	3.5	4.0	4.5	5.0	5.5
	51	101	152	203	253	304	355	405	456	507	557

TABLE 3B
Minimum Airflow (Q_{min}) in CFM

Mc (oz)	Q_{min} (cfm)									
	40	60	80	100	120	140	160	180	200	
	68	101	135	169	203	237	271	304	338	

The maximum refrigerant charge for compliance based on the room area for the total conditioned space can be calculated using the equation below. See Tables 4A and 4B for reference values.

$$M_{max} = CF \times LFL \times H \times TA$$

Where

M_{max} is the maximum allowable refrigerant charge in the system in kg

CF is the concentration factor with a value of 0.50

H is the height of the room = 2.2 m.

TABLE 4A
Maximum Charge (M_{max}) in Kilograms

TA (m^2)	M_{max} (kg)									
	20	40	60	80	100	120	140	160	180	200
	6.5	13.0	19.5	26.0	32.6	39.1	45.6	52.1	58.6	65.1

TABLE 4B
Maximum Charge (M_{max}) in Ounces

TA (ft^2)	M_{max} (oz)									
	100	200	300	400	500	600	700	800	900	1000
	3.0	65.1	97.7	130.2	162.8	195.4	227.9	260.5	293.0	325.6

The minimum total conditioned room area for compliance based on the refrigerant charge may be calculated using the following equation. See Tables 5A and 5B for reference values.

$$TA_{\min} = M_c / (CF \times LFL \times H)$$

Where TA_{\min} is the required minimum area of the total conditioned space in m^2 .

TABLE 5A
Minimum Total Room Area (TA_{\min}) in m^2

Mc (kg)	TA_{\min} (m^2)										
	0.5	1.0	1.5	2.0	2.5	3.0	3.5	4.0	4.5	5.0	5.5
	2	3	5	6	8	9	11	12	14	15	17

TABLE 5B
Minimum Total Room Area (TA_{\min}) in ft^2

Mc (oz)	TA_{\min} (ft^2)									
	40	60	80	100	120	140	160	180	200	
	37	56	75	94	112	131	150	169	187	

Altitude Adjustment

Once A_{\min} , TA_{\min} or M_c has been determined using the methods above, it must be corrected for the final installation site altitude using an Altitude Adjustment Factor (AF). To correct A_{\min} , TA_{\min} or M_c based on a building site's altitude, multiply the calculated area or refrigerant charge by the AF. The AF accounts for reduced air density at higher altitudes. The formula for adjusting the minimum room area is:

$$\text{Adjusted Area} = \text{Original Area} \times \text{AF}$$

In the same way, the formula for adjusting the maximum charge is:

$$\text{Adjusted Maximum Charge} = \text{Original Maximum Charge} \times \text{AF}$$

The AF depends on the specific appliance type and the altitude (H_{alt}) where it will be installed. The formula for calculating AF is:

$$AF = \frac{P_{\text{sea}}}{P_{\text{site}}}$$

where:

P_{site} is the atmospheric pressure at the installation site

P_{sea} level is the standard atmospheric pressure at sea level (usually around 101325 Pa/14.7 psi)

Air pressure above sea level can be calculated as:

$$P_{\text{site}} = 101325 (1 - 2.25577 \cdot 10^{-5} h)^{5.25588}$$

where

101325 = normal temperature and pressure at sea level (Pa)

P_{site} = air pressure (Pa)

h = altitude above sea level (m)

NOTE: P_{site} calculation must be done using SI units as shown. The calculated AF can then be applied to any area units.

See Tables 6A and 6B on page 10 for reference values.

Ventilation of the Conditioned Space

For installations where $M_c > M_{\text{max}}$ for the area of the room, compliance can be achieved with the addition of either natural or mechanical ventilation of the conditioned space. See UL60335-2-40, Annex GG for additional paths to compliance.

14. Unventilated Areas

For units containing more than 62.6 oz (1.775 kg) of R454B refrigerant for any refrigerating circuit, an unventilated area where the appliance is installed shall be so constructed that should any refrigerant leak, it will not stagnate so as to create a fire or explosion hazard.

For units installed in a room with an area less than A_{\min} (see tables 2A and 2B on page 7), but connected via an air duct system to one or more rooms, that room shall be without continuously

TABLE 6A
Example Altitude Adjustment Factors (AF) and Use Example (m)

Site Altitude Above Sea Level (m)	Site Pressure (Pa/PSI)	AF	A _{min} (m ²)					
			50	100	150	200	250	300
0	101325.0/14.7	1.000	50	100	150	200	250	300
1000	89874.6/13.0	0.887	44.3	88.7	133.0	177.4	221.7	266.1
2000	79495.2/11.5	0.785	39.2	78.5	117.7	156.9	196.1	235.4
3000	70108.5/10.2	0.692	34.6	69.2	103.8	138.4	173.0	207.6
4000	61640.2/8.9	0.608	30.4	60.8	91.3	121.7	152.1	182.5
5000	54019.9/7.8	0.533	26.7	53.3	80.0	106.6	133.3	159.9
6000	47181.0/6.8	0.466	23.3	46.6	69.8	93.1	116.4	139.7

TABLE 6B
Example Altitude Adjustment Factors (AF) and Use Example (ft)

Site Altitude Above Sea Level (ft)	Site Pressure (Pa/PSI)	AF	A _{min} (ft ²)					
			50	100	150	200	250	300
0	101325.0/14.7	1.000	50	100	150	200	250	300
1000	97716.7/14.2	0.964	48.2	96.4	144.7	192.9	241.1	289.3
2000	94213.2/13.7	0.930	46.5	93.0	139.5	186.0	232.5	278.9
3000	90812.1/13.2	0.896	44.8	89.6	134.4	179.2	224.1	268.9
4000	87511.2/12.7	0.864	43.2	86.4	129.6	172.7	215.9	259.1
5000	84308.0/12.2	0.832	41.6	83.2	124.8	166.4	208.0	249.6
6000	81200.5/11.8	0.801	40.1	80.1	120.2	160.3	200.3	240.4

operating open flames (i.e., an operating gas appliance) or other potential ignition sources (e.g., an operating electric heater, hot surfaces). A flame-producing device may be installed in the same space if the device is provided with an effective flame arrest.

For units connected via an air duct system to one or more rooms, auxiliary devices which may be a potential ignition source shall not be installed in the duct work. Examples of such potential ignition sources are hot surfaces with a temperature exceeding 700°C and electric switching devices. Only auxiliary devices approved by Bard or declared suitable with R-454B refrigerant shall be installed in connecting ductwork.

For duct connected units, false ceilings or drop ceilings may be used as a return air plenum if a refrigerant detection system (RDS) is provided in the appliance and any external connections are

also provided with a sensor immediately below the return air plenum duct joint. All Bard products containing R-454B refrigerant come with a factory-installed RDS in the appliance. However, any external sensors required for compliance such as those in this example must be field supplied.

For non-duct connected units with the supply and return air openings in the conditioned space, the body of the appliance may be installed in open areas such as false ceilings not being used as return air plenums, as long as the conditioned air does not directly communicate with the air of the false ceiling.

SERVICING SAFETY INFORMATION

1. Checks to the Area

Prior to beginning work on systems containing flammable refrigerants, safety checks are necessary to ensure that the risk of ignition is minimized. For repair to the refrigerating system, the following precautions (items 2-9) shall be complied with prior to conducting work on the system.

2. Work Procedure

Work shall be undertaken under a controlled procedure so as to minimize the risk of a flammable gas or vapor being present while the work is being performed.

Technical personnel in charge of operation, supervision, maintenance of air-conditioning systems shall be adequately instructed and competent with respect to their tasks.

Works shall be undertaken with appropriate tools only. (In case of uncertainty, please consult the manufacturer of the tools for use with flammable refrigerants.)

3. General Work Area

All maintenance staff and others working in the local area shall be instructed on the nature of work being carried out. Work in confined spaces shall be avoided. The area around the work space shall be sectioned off. Ensure that the conditions within the area have been made safe by control of flammable material.

4. Checking for Presence of Refrigerant

The area shall be checked with an appropriate refrigerant detector prior to and during work, to ensure the technician is aware of potentially flammable atmospheres. Ensure that the leak detection equipment being used is suitable for use with flammable refrigerants, e.g., no sparking, adequately sealed or intrinsically safe.

5. Presence of Fire Extinguisher

If any hot work is to be conducted on the refrigeration equipment or any associated parts, appropriate fire extinguishing equipment shall be available on hand. Have a dry power or CO₂ fire extinguisher adjacent to the charging area.

6. No Ignition Sources

No person carrying out work in relation to a refrigerating system which involves exposing any pipe work that contains or has contained flammable refrigerant shall use any sources of ignition in such a manner that it may lead to the risk of fire or explosion. All possible ignition sources, including cigarette smoking, should

be kept sufficiently far away from the site of installation, repairing, removing and disposal, during which flammable refrigerant can possibly be released to the surrounding space. Prior to work taking place, the area around the equipment is to be surveyed to make sure that there are no flammable hazards or ignition risks. NO SMOKING signs shall be displayed.

7. Ventilated Area

Ensure that the area is in the open or that it is adequately ventilated before breaking into the system or conducting any hot work. A degree of ventilation shall continue during the period that the work is carried out. The ventilation should safely disperse any released refrigerant and preferably expel it externally into the atmosphere.

8. Checks to the Refrigeration Equipment

Where electrical components are being changed, they shall be fit for the purpose and to the correct specification. At all times, the manufacturer's maintenance and service guidelines shall be followed. If in doubt, consult the manufacturer's technical department for assistance. The following checks shall be applied to installations using flammable refrigerants:

- The refrigerant charge size is in accordance with the room size within which the refrigerant containing parts are installed.
- The ventilation machinery and outlets are operating adequately and are not obstructed;
- If an indirect refrigerating circuit is being used, the secondary circuits shall be checked for the presence of refrigerant.
- Marking to the equipment continues to be visible and legible marking and signs that are illegible shall be corrected.
- Refrigeration pipe or components are installed in a position where they are unlikely to be exposed to any substance which may corrode refrigerant containing components, unless the components are constructed of materials which are inherently resistant to being corroded or are suitably protected against being so corroded.

9. Checks to Electrical Devices

Repair and maintenance to electrical components shall include initial safety checks and component inspection procedures. If a fault exists that could compromise safety, then no electrical supply shall be connected to the circuit until it is satisfactorily dealt with. If the fault cannot be corrected

immediately but it is necessary to continue operation, an adequate temporary solution shall be used. This shall be reported to the owner of the equipment so all parties are advised.

Initial safety checks shall include:

- That capacitors are discharged: This shall be done in a safe manner to avoid possibility of sparking.
- That no live electrical components and wiring are exposed while charging, recovering or purging the system.
- That there is continuity of earth bonding.

10. Repairs to Sealed Components

Sealed electrical components shall be replaced.

11. Repair to Intrinsically Safe Components

Intrinsically safe components must be replaced.

12. Cabling

During installation, check that field wiring and cabling will not be subject to wear, corrosion, excessive pressure, vibration, sharp edges or any other adverse environmental effects. The check shall also take into account the effects of aging or continual vibration from sources such as compressors or fans.

13. Detection of Flammable Refrigerants

Under no circumstances shall potential sources of ignition be used in the searching for or detection of refrigerant leaks. A halide torch (or any other detector using a naked flame) shall not be used.

14. Leak Detection Methods

The following leak detection methods are deemed acceptable for systems containing flammable refrigerants. Electronic leak detectors may be used to detect refrigerant leaks but, in the case of flammable refrigerants, the sensitivity may not be adequate, or may need re-calibration. (Detection equipment shall be calibrated in a refrigerant-free area.) Ensure that the detector is not a potential source of ignition and is suitable for R-454B refrigerant. Leak detection equipment shall be set at a percentage of the lower flammable limit (LFL) of the refrigerant and shall be calibrated for R-454B and the appropriate percentage of gas (25% maximum) is confirmed. Leak detection fluids are suitable for use with most refrigerants but the use of detergents containing chlorine shall be avoided as the chlorine may react with the refrigerant and corrode the copper pipe-work.

NOTE: Examples of leak detection fluids are:

- Bubble method
- Fluorescent method agents

If a leak is suspected, all naked flames shall be removed or extinguished.

If a leakage of refrigerant is found which requires brazing, all of the refrigerant shall be recovered from the system. In accordance with industry-standard practice, oxygen-free nitrogen (OFN) shall then be purged through the system both before and during the brazing process.

15. Removal and Evacuation

When breaking into the refrigerant circuit to make repairs—or for any other purpose—conventional procedures shall be used. However, for flammable refrigerants it is important that best practice be followed, since flammability is a consideration. The following procedure shall be adhered to:

- Safely remove refrigerant following local and national regulations
- Evacuate
- Purge the circuit with oxygen-free nitrogen
- Evacuate
- Continuously flush or purge with oxygen-free nitrogen when using flame to open circuit
- Open the circuit

The refrigerant charge shall be recovered into the correct recovery cylinders if venting is not allowed by local and national codes. For appliances containing flammable refrigerants, the system shall be purged with oxygen-free nitrogen to render the appliance safe for flammable refrigerants. This process might need to be repeated several times. Compressed air or oxygen shall not be used for purging refrigerant systems.

For appliances containing flammable refrigerants, refrigerants purging shall be achieved by breaking the vacuum in the system with oxygen-free nitrogen and continuing to fill until the working pressure is achieved, then venting to atmosphere, and finally pulling down to a vacuum. This process shall be repeated until no refrigerant is within the system. When the final oxygen-free nitrogen charge is used, the system shall be vented down to atmospheric pressure to enable work to take place.

The outlet for the vacuum pump shall not be close to any potential ignition sources, and ventilation shall be available.

16. Charging Procedures

In addition to conventional charging procedures, the following requirements shall be followed:

- Work shall be undertaken with appropriate tools only. (In case of uncertainty, please consult the manufacturer of the tools for use with flammable refrigerants.)

- Ensure that contamination of different refrigerants does not occur when using charging equipment. Hoses or lines shall be as short as possible to minimize the amount of refrigerant contained in them.
- Cylinders shall be kept upright.
- Ensure that the refrigeration system is earthed prior to charging the system with refrigerant
- Extreme care shall be taken not to overfill the refrigeration system.
- Prior to recharging the system, it shall be pressure tested with oxygen-free nitrogen.

The system shall be leak tested on completion of charging but prior to commissioning. A follow-up leak test shall be carried out prior to leaving the site.

17. Decommissioning

Before carrying out this procedure, it is essential that the technician is completely familiar with the equipment and all its detail. It is recommended good practice that all refrigerants are recovered safely. Prior to the task being carried out, an oil and refrigerant sample shall be taken in case analysis is required prior to re-use of reclaimed refrigerant. It is essential that electrical power is available before the task is commenced.

- Become familiar with the equipment and its operation.
- Isolate system electrically.
- Before attempting the procedure, ensure that:
 - Mechanical handling equipment is available, if required, for handling refrigerant cylinders.
 - All personal protective equipment is available and being used correctly.
 - The recovery process is supervised at all times by a competent person.
 - Recovery equipment and cylinders conform to the appropriate standards.
- Pump down refrigerant system, if possible.
- In order to pull a complete vacuum, fully reclaim the system or charge the unit, connections to all service ports—suction, liquid and discharge—need to be utilized.
- Make sure that cylinder is situated on the scales before recovery takes place in order to ensure refrigerant charge is weighed in properly.
- Start the recovery machine and operate in accordance with manufacturer's instructions.

- Do not overfill cylinders (no more than 80% volume liquid charge).
- Do not exceed the maximum working pressure of the cylinder, even temporarily.
- When the cylinders have been filled correctly and the process completed, make sure that the cylinders and the equipment are removed from site promptly and all isolation valves on the equipment are closed off.
- Recovered refrigerant shall not be charged into another refrigeration system unless it has been cleaned and checked.

18. Labeling

Equipment shall be labeled stating that it has been de-commissioned and emptied of refrigerant. The label shall be dated and signed. Ensure that there are labels on the equipment stating the equipment contains flammable refrigerant.

19. Recovery

When removing refrigerant from a system, either for service or decommissioning, be sure that all refrigerants are removed safely.

When transferring refrigerant into cylinders, ensure that only appropriate refrigerant recovery cylinders are employed. Ensure that the correct numbers of cylinders for holding the total system charge are available. All cylinders to be used are designated for the recovered refrigerant and labeled for that refrigerant (i.e., special cylinders for the recovery of refrigerant). Cylinders shall be complete with pressure relief valve and associated shut-off valves in good working order.

The recovery equipment shall be in good working order with a set of instructions concerning the equipment that is at hand and shall be suitable for the recovery of the flammable refrigerant. If in doubt, the manufacturer should be consulted. In addition, a set of calibrated weighing scales shall be available and in good working order. Hoses shall be complete with leak-free disconnect couplings and in good condition.

The recovered refrigerant shall be processed according to local legislation in the correct recovery cylinder, and the relevant waste transfer note arranged. Do not mix refrigerants in recovery units and especially not in cylinders.

If compressors or compressor oils are to be removed, ensure that they have been evacuated to an acceptable level to make certain that flammable refrigerant does not remain within the lubricant. The compressor body shall not be heated by an open flame or other ignition sources to accelerate this process. When oil is drained from a system, it shall be carried out safely.

If compressors or compressor oils are to be removed, ensure that they have been evacuated to an acceptable level to make certain that flammable refrigerant does not remain within the lubricant. The compressor body shall not be heated by an open flame or other ignition source to accelerate this process. When oil is drained from a system, it shall be carried out safely.

20. Transport of Equipment Containing Flammable Refrigerants

Additional transportation regulations may exist with respect to equipment containing flammable gas. The maximum number of pieces of equipment or the configuration of the equipment permitted to be transported together will be determined by the applicable transport regulations.

21. Marking of Equipment Using Signs

Signs for similar appliances used in a work area are generally addressed by local regulations and give the minimum requirements for the provision of safety and/or health signs for a work location. All required signs are to be maintained and employers should ensure that employees receive suitable and sufficient instruction and training on the meaning of appropriate safety signs and the actions that need to be taken in connection with these signs. The effectiveness of signs should not be diminished by too many signs being placed together. Any pictograms used should be as simple as possible and contain only essential details.

22. Disposal of Equipment Using Flammable Refrigerants

See national regulations.

23. Storage of Equipment/Appliances

The storage of the appliance should be in accordance with the applicable regulations or instructions provided by Bard, whichever is more stringent.

24. Storage of Packed (Unsold) Equipment

Storage package protection should be constructed in such a way that mechanical damage to the equipment inside the package will not cause a leak of the refrigerant charge. The maximum number of pieces of equipment permitted to be stored together will be determined by local regulations.

Explanation of Symbols Displayed on the Unit



This symbol indicates that the unit contains a mildly flammable refrigerant.



This symbol indicates that the refrigerant used is classified as an A2L, or mildly flammable refrigerant.



This symbol indicates that the Operation Manual should be read carefully.



This symbol indicates that a service personnel should be handling this equipment with reference to the Installation Manual.



This symbol indicates that information is available such as the Operation Manual or Installation Manual.

REFRIGERANT LEAK DETECTION SYSTEM (RDS)

For information about the Refrigerant Leak Detection System (RDS), see unit installation manual.

SERVICING PROCEDURES

WARNING

The oils used with R-454B refrigerant are hygroscopic and absorb water from the atmosphere readily. Do not leave systems open to the atmosphere for more than 5 minutes. If the system has been open for more than 5 minutes, change the filter dryer immediately before evacuation. Then recharge the system to the factory-specified charge.

Recovery Equipment Rated for R-454B Refrigerant

R-454B has an ozone depletion potential of zero, but must be reclaimed due to its global warming potential.

R-454B refrigerant operates at pressures similar to R-410A. The gauge manifold set must be designed to withstand the higher pressure associated with R-454B. Manifold sets are required to range up to 800 psig on the high side and 250 psig on the low side with a 250 psig low side retard.

All hoses must have a service rating of 800 psig. (This information will be indicated on the hoses.)

Vacuum pump and micron gauge must be used when evacuating a system to 500 microns.

Leak Detectors

An electronic leak detector rated for use with flammable refrigerants can be used with R-454B refrigerant.

Gauge Manifold

WARNING

Gauge manifold must be suitable for use with R-454B refrigerant and POE oils.

A necessary instrument in checking and serving air conditioning and heat pump equipment is the gauge manifold. Its purpose is to determine the operating refrigerant pressures in order for the service technician to analyze the condition of the system.

The valving on the manifold is so arranged that when the valves are closed (front-seated) the center port on the manifold is closed to the gauges and gauge ports.

With the valves in the closed position, the gauge ports are still open to the gauges, permitting the gauges to register system pressures. Opening either valve opens the center port to that side of the manifold and system.

Attaching Gauge Manifold

For leak testing, purging, checking charge, charging liquid or evacuating, connect high pressure side of gauge manifold to Schrader valve on liquid or discharge line. Connect suction side of gauge manifold to Schrader valve on suction line. On heat pumps the suction line is between compressor and reversing valve.

WARNING

As a safety measure, it is wise to attach refrigerant hoses at the points of lowest pressure in the system. To do this:

- A. Put high pressure hose "B" on first. (Unit should not be running.)*
- B. Put low pressure hose "A" on second. (Unit should be running.)*

Attaching manifold hose to Schrader valve:

1. Remove cap from valve.
2. Make sure gauge manifold valves are closed.
3. If hose does not have an unseating pin, a number 395 Superior or equivalent unseating coupler must be used.
4. Make sure coupler is lined up straight with Schrader valve. Screw coupler onto valve.
5. Open gauge manifold valve slightly and purge air from hose with refrigerant.
6. Read the suction pressure on compound gauge and heat pressure on pressure gauge.
7. To remove, push end of hose tight against end of Schrader valve and hold in place while quickly unscrewing coupler nut from Schrader valve.
8. Remove coupler from Schrader valve. Replace caps on valve.

Leak Test

1. If the system still contains refrigerant when a leak is suspected, check all soldered joints and areas of suspicion with an electronic leak detector suitable for use with R-454B refrigerant.

NOTE: Older R-22 leak detectors will not detect leaks in R-454B systems.

2. If no leak is found in Step 1, or the total refrigerant charge has leaked out, recover remaining refrigerant from the system and evacuate. (See **Evacuation** section below and unit installation manual for more information.)

NOTE: When working on an R-454B system, recovery pumps, vacuum pumps and charging cylinders should be connected to an earth ground at all times during use.

3. Remove gauge port cap from suction and liquid service valve ports and attach manifold gauge hoses. Connect an upright cylinder of oxygen-free dry nitrogen (OFN) to center port of gauge manifold. Open nitrogen cylinder valve and manifold high pressure gauge valve to pressurize system to a positive pressure with OFN vapor. Pressurize the complete system until the pressure reaches 200 psig. Do not exceed 250 psig.
4. Close manifold high pressure gauge valve. Check all soldered joints, including those on the evaporator coil, by spraying with a soap and water solution and looking for bubbles. If a leak is found which requires soldering, pressure in the system must be bled off since it is impossible to solder with unit pressurized. Be sure all leaks are located and marked before bleeding pressure from system.
5. Close OFN tank valve and disconnect from center port. Release nitrogen into the atmosphere through suction line of gauge manifold.
6. Correct any leaks and recheck.
7. Replace filter drier. The liquid line filter dryer (R-454B compatible) must be replaced any time the system is open. When removing a filter dryer from a system, do not use a torch; use a tubing cutter to avoid releasing moisture back into the system.
8. Once filter drier has been replaced, recheck for leaks. When leaks, if any, have been repaired, system is ready to be evacuated and charged. Relieve all pressure from the system down to 0 psig.

REMEMBER: Always use a pressure regulator with nitrogen and a safety valve down stream.

Evacuation

An evacuation to 500 microns is usually sufficient to remove moisture from a system using R-22 and mineral oil lubricant. A 500 micron evacuation, however, will not separate moisture from Polyol Ester oil (POE) in R-454B systems.

1. Evacuate system to less than 500 microns, using a good vacuum pump designed for use with flammable refrigerants and an accurate high vacuum gauge. Operate the pump below 500 microns for 60 minutes and then close valve to

the vacuum pump. Allow the system to stand for 30 additional minutes to be sure a 500 micron vacuum or less is maintained.

WARNING

Do not use the compressor to evacuate the system or any part of it.

2. Disconnect charging line at vacuum pump and connect to refrigerant supply. Crack the cylinder valve and purge charging line at center on manifold. Then close cylinder valve.
3. The system is now ready for the correct operating charge of refrigerant R-454B.

R-454B System Charging

Even though R-454B has a low fractionation potential, it cannot be ignored when charging. For this reason, R-454B systems should never be "topped off". The remaining system charge should always be recovered, the system evacuated, and then charged to the amount shown on the unit serial plate. To avoid fractionation, charging of an air conditioner or heat pump system incorporating R-454B shall be done with "liquid" to maintain optimum system performance. To ensure that the proper blend composition is charged into the system, it is important that liquid only be removed from the charging cylinder.

Some cylinders supplied by manufacturers have dip tubes which allow liquid refrigerant to be removed from the cylinder when it is in the upright position. Cylinders without dip tubes have to be tipped upside down in order for liquid to be removed. The service technician must differentiate between which type of charging cylinder they are using to avoid removing vapor refrigerant instead of liquid refrigerant to avoid fractionation and for safety concerns.

Allow liquid to enter the high side only. The high side will hold 80-100% of the total charge. When liquid stops flowing, close high-side port. The remainder of the charge will be added to the low side. Keep in mind two issues: First, never start the compressor with less than 55 psig of suction pressure. Secondly, make sure the liquid is throttled, thus vaporized into the low side of the system to avoid compressor damage. A throttling valve can be used to ensure that liquid is converted to vapor prior to entering the system. Proper manipulation (restricting) of the manifold gauge set can also act as a throttling device to ensure liquid is not entering the compressor.

For single package units, refer to the unit serial plate for the full operating charge.

Preliminary Charging Steps

If the system has been open to the atmosphere, the filter dryer should be replaced and then evacuated. Then proceed as follows:

1. Attach a cylinder of proper, clean refrigerant to the center port of the charging manifold with one of the charging hoses.
2. Attach a second charging hose to the suction gauge (low pressure) side of the gauge manifold.
3. Remove the cap from the suction line valve.
4. Loosely attach the suction gauge hose to the line valve. Open the valve on the refrigerant cylinder and the suction valve on the charging manifold slightly to purge the air from the manifold and hoses before tightening the fitting.
5. Attach the third hose to the high pressure side of the manifold and the liquid line valve. Repeat Steps 3 and 4 above.

Charging the System by Weight

1. Connect manifold as instructed.
2. Place refrigerant cylinder on scale and determine exact weight of the refrigerant and cylinder.
3. With manifold suction valve closed and manifold discharge valve open, open refrigerant cylinder liquid valve and allow pressure in system to balance with pressure of cylinder or 80% of charge is in the unit—whichever comes first.
4. When there is approximately an 80% charge, front seat (close) the discharge manifold valve and let the system stabilize for about five minutes.
5. Start compressor by setting thermostat.
6. Finish charging with liquid by cracking the suction valve. Open the manifold low pressure valve to allow refrigerant to flow into the system. Throttle the manifold valve to keep pressure about 100 psig for R-454B.
7. When the correct weight of refrigerant has been added to the unit, close refrigerant cylinder valve and allow unit to run for 30 minutes. Refer to Start-Up Procedure and Check List for further start-up details.
8. Front seat gauge manifold valves, disconnect charging and gauge hoses and replace all valve caps.

EEV Instructions for Recovering, Evacuating and Charging the Unit

Some Bard units use an electronic expansion device to meter refrigerant. In these units, the electronic expansion valve moves to a closed position when there is no call to control. In order to pull a complete vacuum, fully recover the system or charge the unit, connections to all service ports—suction, liquid and discharge—need to be utilized or the valve needs to be manually opened first. The valve can be opened manually using the magnetic EEV service tool (Bard Part # 2151-021) shown in Figure 2. To do this, remove the EEV stator coil (red color with retaining nut on top), slide the magnetic tool over the shaft where the stator was removed and turn in a clockwise direction to open the valve to the full open position (directional arrows are provided on the tool).

Reapply the EEV stator coil and retaining nut once complete. Upon powering the unit back up, the control board will automatically drive the EEV back to the fully shut position. Once the compressor starts, the control board will again modulate the EEV position to control the system superheat.

FIGURE 2
Electronic Expansion Valve (EEV) and Service Tool

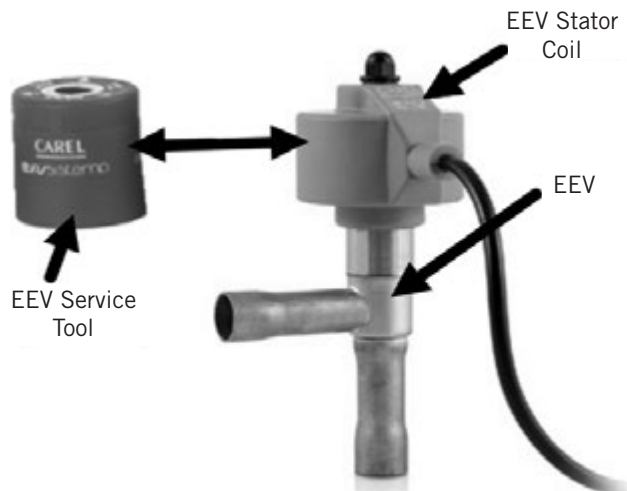

WARNING

To speed refrigerant flow, it may be necessary to place refrigerant cylinder in a pan of warm water (not greater than 130°F). Remember to either consider the total weight of the pan of water or remove the cylinder for weighing frequently to keep track of the charging process.

FIGURE 3
Typical Air Conditioning System Cooling Cycle

TYPICAL AIR CONDITIONING SYSTEM COOLING CYCLE

HIGH. PRESS. VAPOR - - - - -
 LOW PRESS. VAPOR - - - - -
 HIGH PRESS. LIQUID - - - - -
 LOW PRESS. LIQUID - - - - -

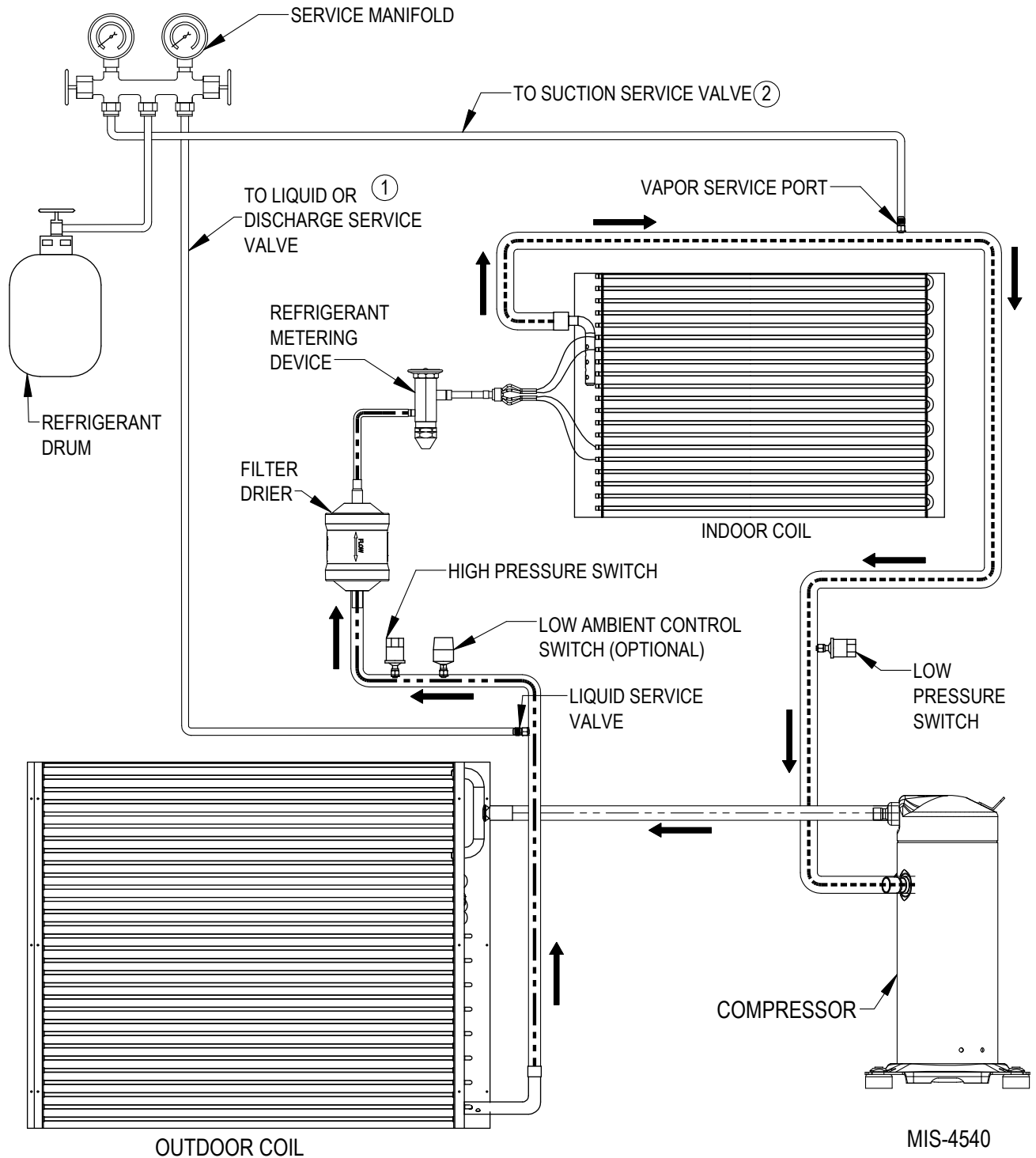

FIGURE 4
Typical Heat Pump System Cooling Cycle

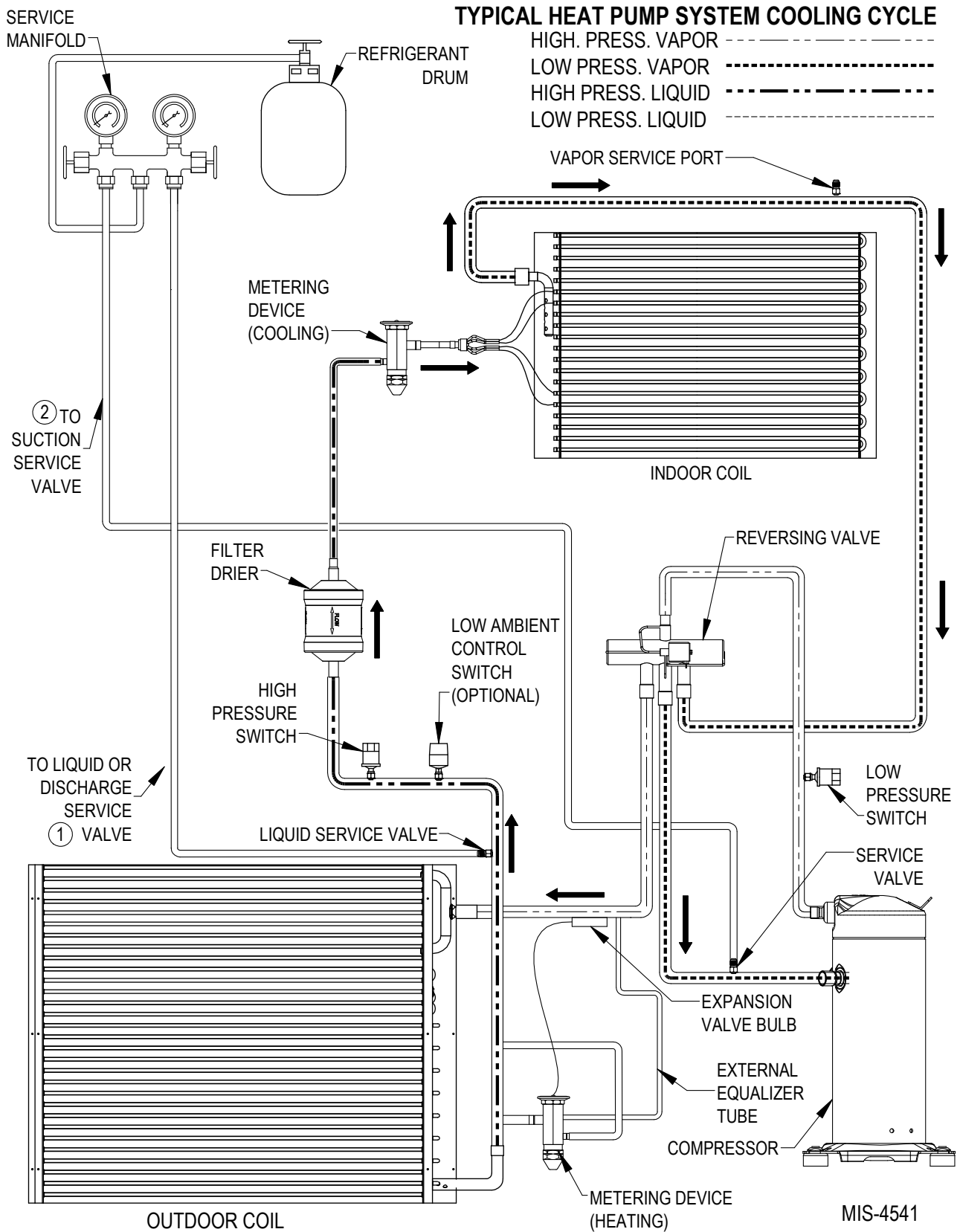

FIGURE 5
Heating Cycle

TYPICAL HEAT PUMP SYSTEM HEATING CYCLE

HIGH. PRESS. VAPOR ————
 LOW PRESS. VAPOR - - - - -
 HIGH PRESS. LIQUID ————
 LOW PRESS. LIQUID - - - - -

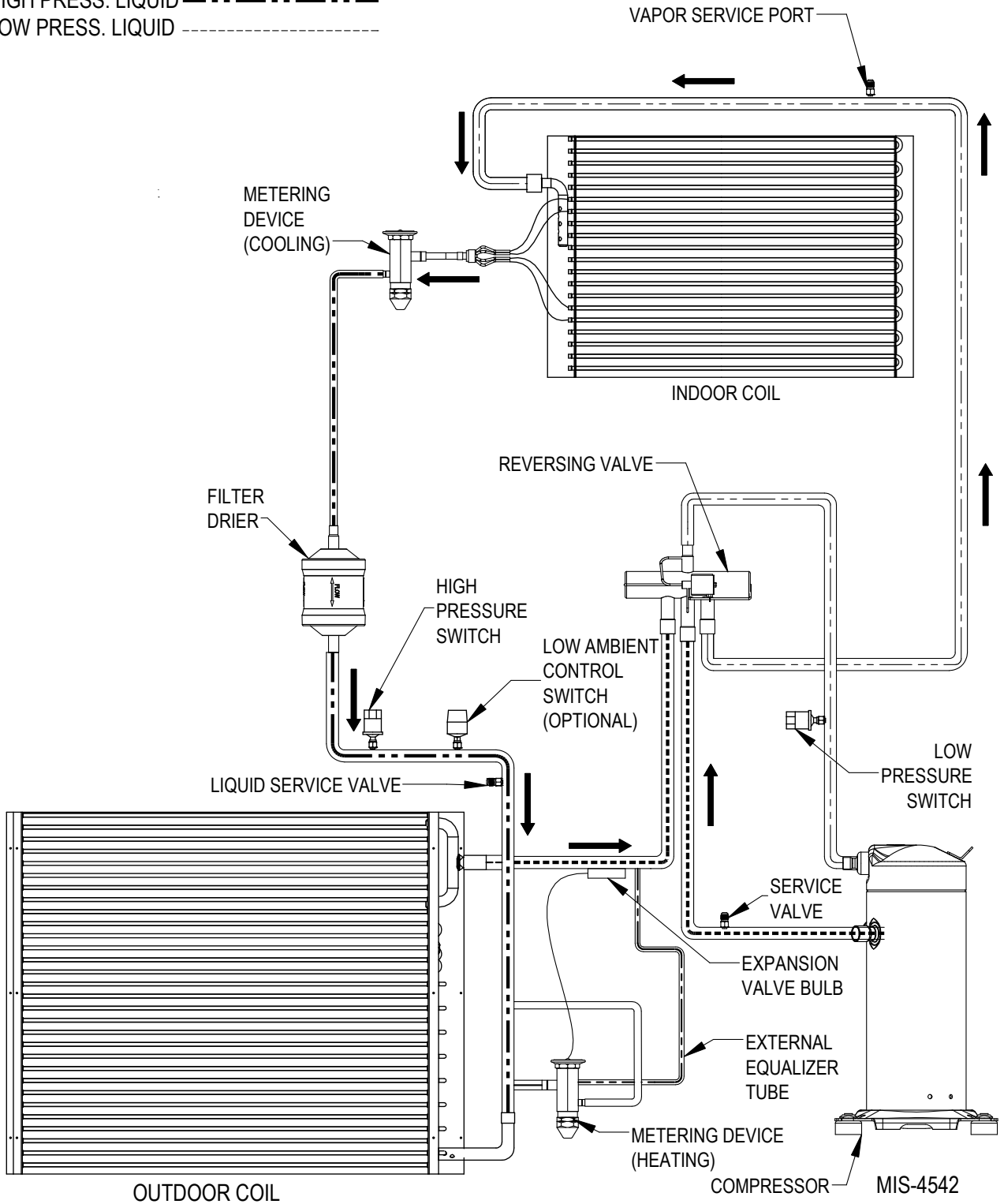

FIGURE 6
Air Conditioning Mode Circuit Diagram

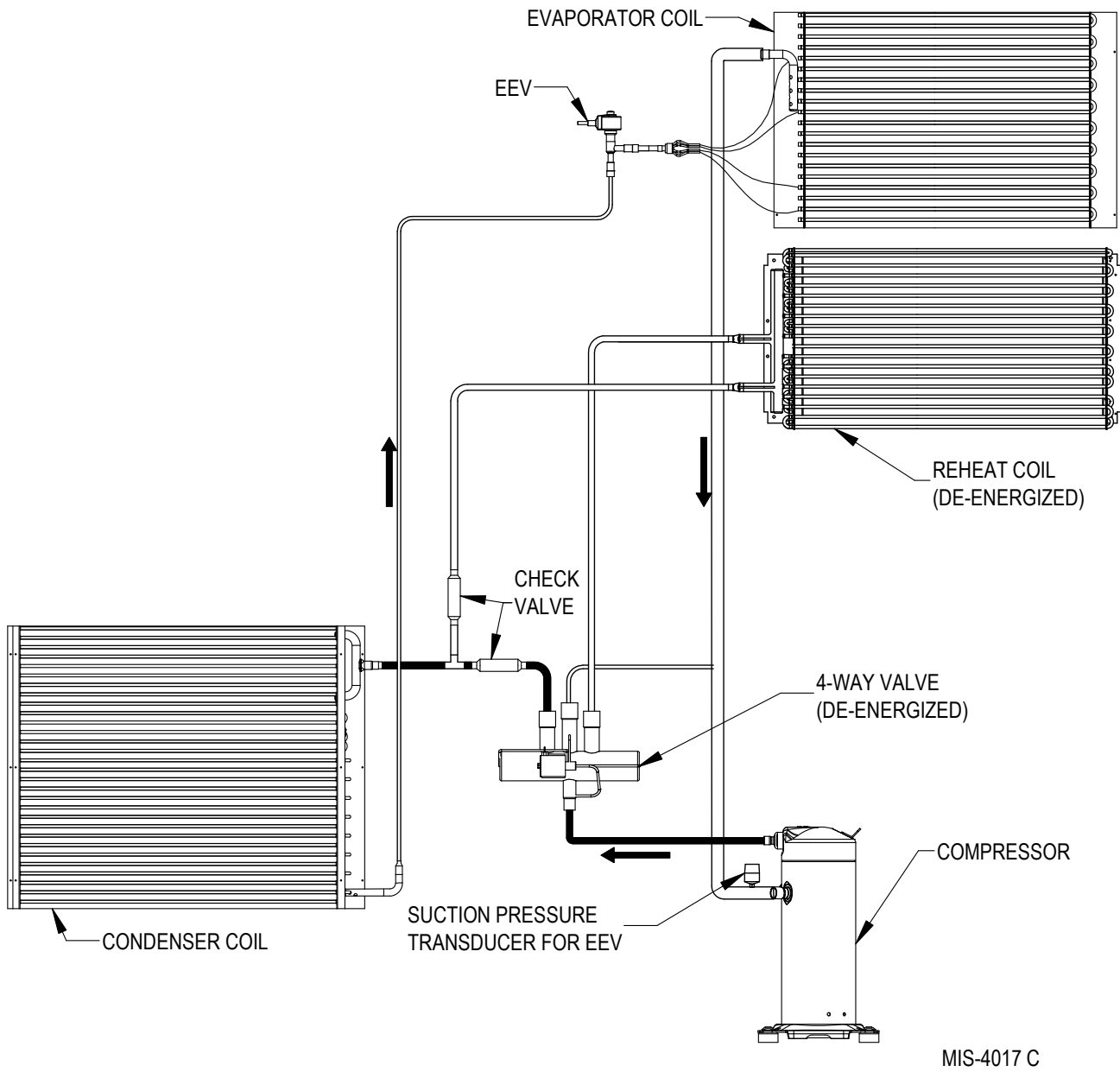
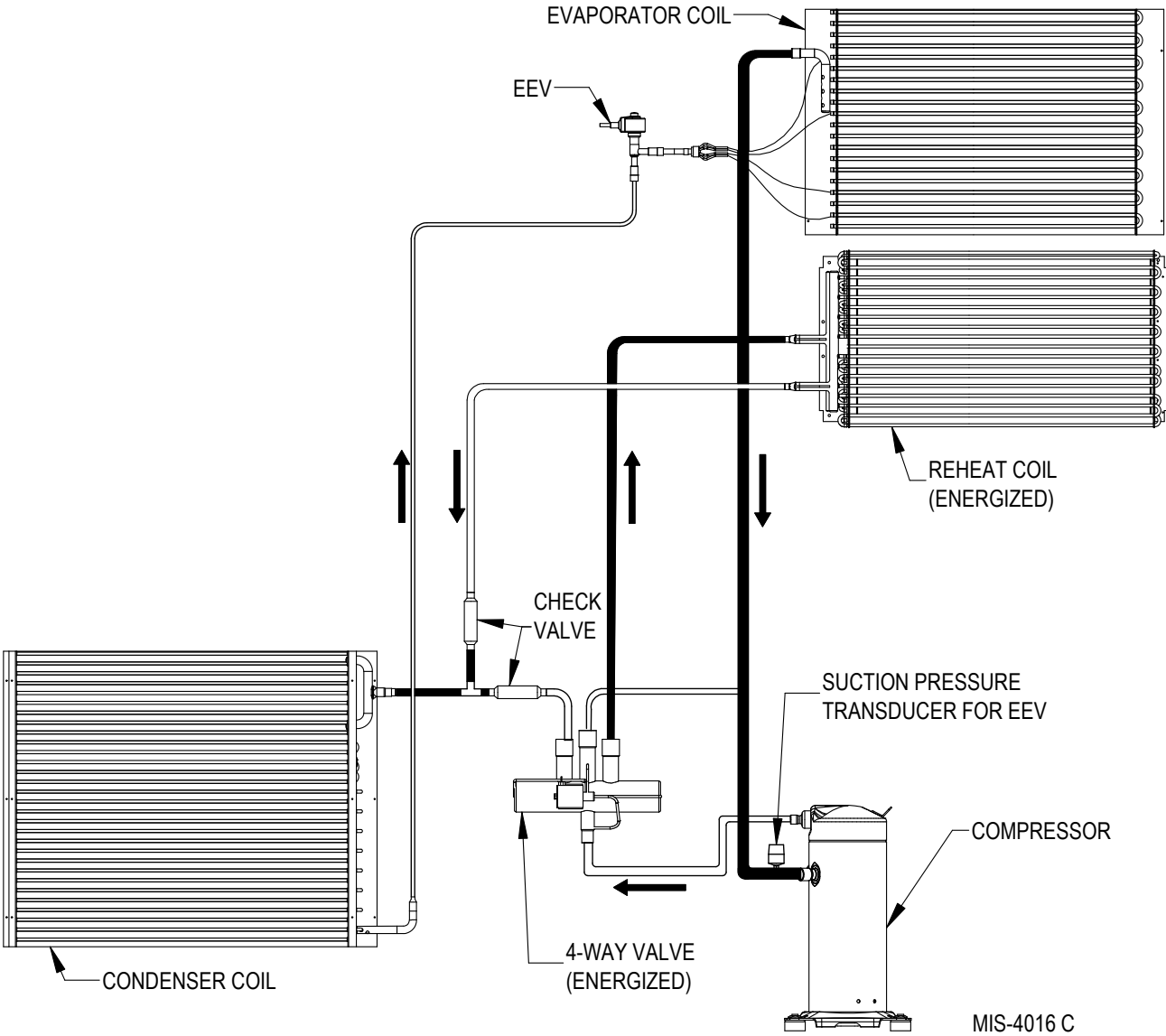

FIGURE 7
Dehumidification Mode Circuit Diagram



TROUBLESHOOTING THE MECHANICAL SYSTEM

Air Conditioning and Heat Pump – Cooling

Low Suction – Low Head Pressure

1. Restricted airflow over indoor coil
2. Defective indoor fan motor
3. Low indoor temperature
4. Iced indoor coil
5. Restricted liquid line, dryer, metering device, etc.
6. Low charge
7. Low ambient entering air temperature. (Low entering water temperature to water coil.®)

High Suction – Low Head Pressure

1. Defective or broken valves
2. IPRV valve open
3. Defective reversing valve

Low Suction – High Head Pressure

1. Partial restriction and then overcharged

High Suction – High Head Pressure

1. High entering outdoor air temperature. (High entering water temperature.®)
2. Low airflow outdoor coil. (Low water flow.®)
3. Overcharged
4. Air in system
5. Restricted outdoor coil. (Restricted water coil.®)
6. High indoor air temperature

Heat Pump – Heating

Low Suction – Low Head Pressure

1. Restricted airflow through outdoor coil. (Restricted water flow through water coil.®)
2. Defective outdoor motor. (Defective water pump.®)
3. Low outdoor air temperature. (Low water temperature.®)
4. Frozen outdoor coil. (Frozen water coil.®)
5. Restricted liquid line, dryer, metering device, etc.
6. Low charge
7. Low indoor air temperature

High Suction – Low Head Pressure

1. Defective or broken valves
2. IPR valve open
3. Defective reversing valve

Low Suction – High Head Pressure

1. Partial restriction and then overcharged

High Suction – High Head Pressure

1. High entering outdoor air temperature. (High entering water temperature.®)
2. Low indoor airflow
3. Overcharged
4. Air in system
5. Restricted air coil
6. High indoor air temperature

® Water source heat pump

TROUBLESHOOTING CHART FOR AIR CONDITIONERS

	Power Supply										High Pressure Side of System										Low Side										General																																			
	Melter to Line Side of Contactor					Load Side of Contactor to Motor Terminal					Control Circuit					Motors					Compressor					System Operation					Condenser Air					Evaporator Air					General																									
• Power Failure	• Blown Fuses or Tripped Circuit Breakers	• Faulty Wiring	• Loose Terminals	• Low Voltage	• Single 1PH Failure of 3PH	• Unbalanced Power Supply 3PH	• Voltage Too High	• Open Disconnect Switch	• Faulty Wiring	• Loose Terminal	• Low Voltage	• Defective Contacts in Contactor	• Compressor Overload	• Potential Relay Fails to Open	• Potential Relay Fails to Close	• Run Capacitor	• Start Capacitor	• Faulty Wiring	• Loose Terminals	• Control Transformer	• Low Voltage	• Thermostat	• Contactor Coil	• Pressure Control	• Condenser Fan Relay	• Evaporator Fan Relay	• Compressor Motor	• Condenser Motor	• Evaporator Motor	• Compressor Off on Internal Overload	• Hold Down Bolts	• Defective Compressor Bearings	• Seized Compressor	• Defective Compressor Valves	• Compressor Oil Level	• Open or Short Motor Windings	• Refrigerant Charge Low	• Overcharge of Refrigerant	• High Head Pressure	• High Suction Pressure	• Low Suction Pressure	• Temperatures	• Non-Condensables (Air, etc.)	• Excessive Load in Space	• Liquid Valve Partially Closed	• Condenser Fins Dirty or Plugged	• Condenser Fan Belt Slipping	• Condenser Air Short Circuiting	• Low Condenser Air Volume	• Condenser Air Temperature Low	• Plugged or Restricted Metering Device	• Evaporator Fins Dirty or Plugged	• Evaporator Belt Slipping	• Low Evaporator Air Volume	• Dirty Filters	• Ductwork Small or Restricted	• Restrictions	• Thermostat Setting	• Thermostat Location	• Stratified Air in Space	• Incorrect Refrigerant Piping	• System Too Small				
• Generally the cause. Always make these checks first.	• Occasionally the cause. Make these checks only if first checks fail to locate trouble.	• Rarely the cause. Make this check only if previous checks fail to locate trouble.	• Compressor and condenser fan motor will start but compressor fan will not run	• Condenser fan motor will not start	• Compressor "hums" but will not start	• Compressor cycles on overload	• Compressor short cycles on low pressure	• Compressor runs continuously—no cooling	• Compressor runs continuously—cooling	• Compressor noisy	• Compressor leaks oil	• Head pressure too high	• Head pressure too low	• Liquid line frosting or sweating	• Suction pressure too high	• Suction pressure too low	• Evaporator frosting	• Suction line frosting or sweating	• Evaporator blower will not start	• Condenser fan motor runs but not pulled in	• Liquid refrigerant flooding back to compressor—cap. tube system	• Space temperature too high	• Faulty Wiring	• Loose Terminals	• Low Voltage	• Thermostat	• Contactor Coil	• Pressure Control	• Condenser Fan Relay	• Evaporator Fan Relay	• Compressor Motor	• Condenser Motor	• Evaporator Motor	• Compressor Off on Internal Overload	• Hold Down Bolts	• Defective Compressor Bearings	• Seized Compressor	• Defective Compressor Valves	• Compressor Oil Level	• Open or Short Motor Windings	• Refrigerant Charge Low	• Overcharge of Refrigerant	• High Head Pressure	• High Suction Pressure	• Low Suction Pressure	• Temperatures	• Non-Condensables (Air, etc.)	• Excessive Load in Space	• Liquid Valve Partially Closed	• Condenser Fins Dirty or Plugged	• Condenser Fan Belt Slipping	• Condenser Air Short Circuiting	• Low Condenser Air Volume	• Condenser Air Temperature Low	• Plugged or Restricted Metering Device	• Evaporator Fins Dirty or Plugged	• Evaporator Belt Slipping	• Low Evaporator Air Volume	• Dirty Filters	• Ductwork Small or Restricted	• Restrictions	• Thermostat Setting	• Thermostat Location	• Stratified Air in Space	• Incorrect Refrigerant Piping	• System Too Small

REPLACEMENT PARTS MANUAL

Wall Mount Heat Pump Models:

C36HF-A	C42HF-A	C48HF-A	C60HF-A
C36HF-B	C42HF-B	C48HF-B	C60HF-B
C36HF-C	C42HF-C	C48HF-C	C60HF-C
C36HFDA	C42HFDA	C48HFDA	C60HFDA
C36HFDB	C42HFDB	C48HFDB	C60HFDB
C36HFDC	C42HFDC	C48HFDC	C60HFDC

Contents

Description	Page	Description	Page
Wall Mount Heat Pump Nomenclature	2	Control Panel – 460V 3PH	
External Parts – Standard & Dehum		♦ Layout View	24
♦ Exploded View	4	♦ Usage List	25
♦ Usage List	5	♦ Usage List	26
♦ Usage List	6	EEV Controller Assembly	
External Parts – Recessed Cabinet		♦ Exploded View	27
♦ Exploded View	8	♦ Usage List	27
♦ Usage List	9	Blower Assembly	
Internal Parts – Standard & Dehum		♦ Exploded View	28
♦ Exploded View	10	♦ Usage List	28
♦ Usage List	11		
♦ Usage List	12		
Functional Components – Standard & Dehum			
♦ Exploded View	14		
♦ Usage List	15		
♦ Usage List	16		
♦ Usage List	17		
♦ Usage List	18		
Control Panel – 230V 1PH & 230V 3PH			
♦ Layout View	20		
♦ Usage List	21		
♦ Usage List	22		

General Notes

- Revised and/or additional pages may be issued from time to time.
- A complete and current manual consists of pages shown in the following contents section.

Important

- Contact the installing and/or local Bard distributor for all parts requirements. Make sure to have the complete model and serial number available from the unit rating plates.



Bard Manufacturing Company, Inc.
Bryan, Ohio 43506
www.bardhvac.com

Manual: 2110-1587
Supersedes: **NEW**
Date: 11-12-24

Climate Control Solutions

WALL MOUNT HEAT PUMP MODEL NOMENCLATURE

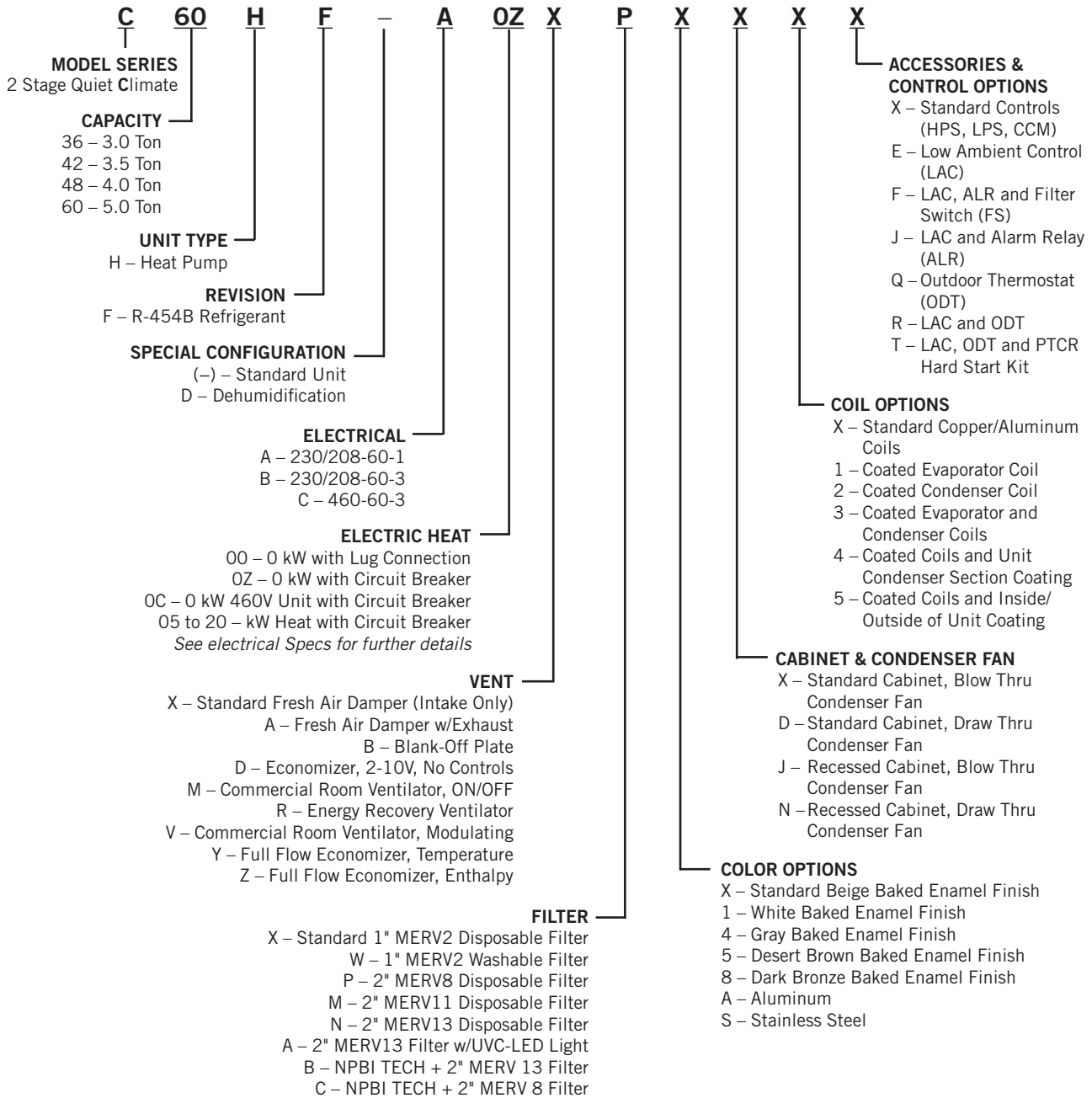

NOMENCLATURE NOTES:

- C36, C42, C48 and C60 models have the unit control panel located in the front of the unit.
- Accessories and control options may not be available for all models. See Specifications Sheet S3660 for further details.
- All units have an external data tag with the model and serial number on the left side of the unit. A secondary data tag with the model and serial number is located inside the control panel area on or near the low voltage terminal box.
- Aluminum and stainless steel cabinet finish not available in units with recessed cabinet top.
- Only "X" Cabinet and Condenser Fan option (Standard Cabinet, Blow Thru Condenser Fan) is available with dehum units.

This page intentionally left blank

EXTERNAL PARTS – STANDARD & DEHUMIDIFICATION

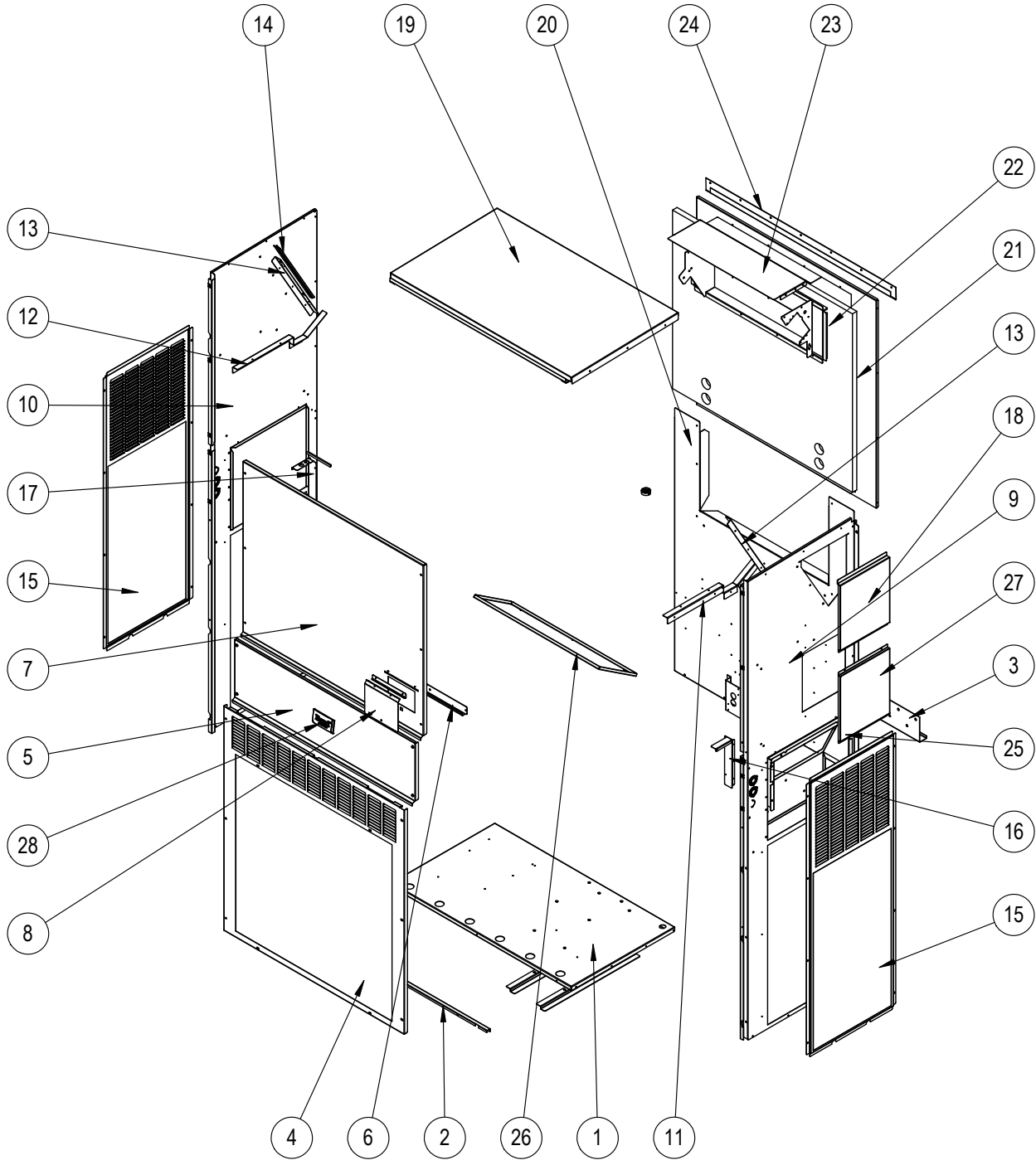

SEXP-1099

This drawing to be used for reference for pages 5 and 6

EXTERNAL PARTS – STANDARD & DEHUMIDIFICATION

Dwg No.	Part Number	Description	C36HF-A, B, C	C36HFDA, B, C	C42HF-A, B, C	C42HFDA, B, C	C48HF-A, B, C	C48HFDA, B, C	C60HF-A, B, C	C60HFDA, B, C
1	127-616BX	Base (only)	X	X	X	X	X	X	X	X
1	527-616BX	Base Assembly w/Compressor Plate	X	X	X	X	X	X	X	X
1	127-617BX ③	Base (only)	0	0	0	0	0	0	0	0
1	527-617BX ③	Base Assembly w/Compressor Plate	0	0	0	0	0	0	0	0
2	113-762BX	Front Base Bracket	X	X	X	X	X	X	X	X
2	113-797BX ③	Front Base Bracket	0	0	0	0	0	0	0	0
3	113-140BX	Bottom Mounting Bracket	X	X	X	X	X	X	X	X
4	119-125-*BX ①	Front Grille	X	X	X	X				
4	119-148BX ②	Front Grille	0	0	0	0				
4	119-135BX ③	Front Grille	0	0	0	0				
4	119-127-*BX ①	Front Grille					X	X	X	X
4	119-149BX ②	Front Grille					0	0	0	0
4	119-137BX ③	Front Grille					0	0	0	0
5	533-301-*BX ①	Control Panel Cover (Outer)	X	X	X	X	X	X	X	X
5	533-309BX ②	Control Panel Cover (Outer)	0	0	0	0	0	0	0	0
5	533-310BX ③	Control Panel Cover (Outer)	0	0	0	0	0	0	0	0
6	165-608-*BX ①	Rain Channel	X	X	X	X	X	X	X	X
6	165-609BX ②	Rain Channel	0	0	0	0	0	0	0	0
6	165-610BX ③	Rain Channel	0	0	0	0	0	0	0	0
For CABINET & CONDENSER FAN character X or D only (refer to page 2)										
7	515-323-*BX ①	Upper Front	X	X	X	X				
7	515-328BX ②	Upper Front	0	0	0	0				
7	515-330BX ③	Upper Front	0	0	0	0				
7	515-324-*BX ①	Upper Front					X	X	X	X
7	515-329BX ②	Upper Front					0	0	0	0
7	515-331BX ③	Upper Front					0	0	0	0
8	153-717-*BX ①	Disconnect Access Door	X	X	X	X	X	X	X	X
8	153-723BX ②	Disconnect Access Door	0	0	0	0	0	0	0	0
8	153-724BX ③	Disconnect Access Door	0	0	0	0	0	0	0	0
For CABINET & CONDENSER FAN character X or D only (refer to page 2)										
9	501-1127-*BX ①	Right Side Assembly	X	X	X	X				
9	501-1128BX ②	Right Side Assembly	0	0	0	0				
9	501-1129BX ③	Right Side Assembly	0	0	0	0				
9	501-1130-*BX ①	Right Side Assembly					X	X	X	X
9	501-1131BX ②	Right Side Assembly					0	0	0	0
9	501-1132BX ③	Right Side Assembly					0	0	0	0
For CABINET & CONDENSER FAN character X or D only (refer to page 2)										
10	501-1054-*BX ①	Left Side Assembly	X	X	X	X				
10	501-1073BX ②	Left Side Assembly	0	0	0	0				
10	501-1077BX ③	Left Side Assembly	0	0	0	0				
10	501-1056-*BX ①	Left Side Assembly					X	X	X	X
10	501-1075BX ②	Left Side Assembly					0	0	0	0
10	501-1079BX ③	Left Side Assembly					0	0	0	0
11	105X1454BX	Right Support Angle	X	X	X	X	X	X	X	X
12	105Y1454BX	Left Support Angle	X	X	X	X	X	X	X	X
13	105-1457BX	Coil Support	2	2	2	2				
13	105-1455BX	Coil Support					2	2	2	2

Continued on page 6

① Exterior cabinet parts are manufactured with various paint color options. To ensure the proper paint color is received, include the complete model and serial number of the unit for which cabinet parts are being ordered.

② Exterior cabinet parts are manufactured from aluminum Code "A"

③ Exterior cabinet parts are manufactured from stainless steel Code "S"

X – Standard Component
O – Optional Component

EXTERNAL PARTS – STANDARD & DEHUMIDIFICATION

Dwg No.	Part Number	Description	C36HF-A, B, C	C36HFDA, B, C	C42HF-A, B, C	C42HFDA, B, C	C48HF-A, B, C	C48HFDA, B, C	C60HF-A, B, C	C60HFDA, B, C
<i>Continued from page 5</i>										
14	147-055BX	Coil Support Offset	X	X	X	X				
14	147-054BX	Coil Support Offset					X	X	X	X
15	119-126-*BX ①	Side Grille	2	2	2	2				
15	119-142BX ②	Side Grille	2	2	2	2				
15	119-136BX ③	Side Grille	2	2	2	2				
15	119-128-*BX ①	Side Grille					2	2	2	2
15	119-143BX ②	Side Grille					2	2	2	2
15	119-138BX ③	Side Grille					2	2	2	2
16	105-1450BX	Right Control Panel Angle	X	X	X	X	X	X	X	X
17	105-1451BX	Left Control Panel Angle	X	X	X	X	X	X	X	X
18	543-221-*BX ①	Heater Access Cover	X	X	X	X	X	X	X	X
18	543-228BX ②	Heater Access Cover	0	0	0	0	0	0	0	0
18	543-229BX ③	Heater Access Cover	0	0	0	0	0	0	0	0
For CABINET & CONDENSER FAN character X or D only (refer to page 2)										
19	507-382-*BX ①	Top	X	X	X	X	X	X	X	X
19	507-391BX ②	Top	0	0	0	0	0	0	0	0
19	507-392BX ③	Top	0	0	0	0	0	0	0	0
20	109-412BX	Lower Back	X	X	X	X				
20	109-418BX	Lower Back	0	0	0	0				
20	109-422BX ③	Lower Back	0	0	0	0				
20	109-414BX	Lower Back					X	X	X	X
20	109-420BX	Lower Back					0	0	0	0
20	109-424BX ③	Lower Back					0	0	0	0
21	509-411BX	Upper Back	X	X	X	X				
21	509-417BX	Upper Back	0	0	0	0				
21	509-421BX ③	Upper Back	0	0	0	0				
21	509-413BX	Upper Back					X	X	X	X
21	509-419BX	Upper Back					0	0	0	0
21	509-423BX ③	Upper Back					0	0	0	0
22	111-299BX	Outlet Air Frame Assembly	X	X	X	X	X	X	X	X
23	535-129BX	Heat Shield	X	X	X	X	X	X	X	X
24	113-150-*BX ①	Top Rain Flashing	X	X	X	X	X	X	X	X
24	113-150-4BX ②	Top Rain Flashing	0	0	0	0	0	0	0	0
24	113-359BX ③	Top Rain Flashing	0	0	0	0	0	0	0	0
25	539-406BX	Fresh Air Damper Assembly	X	X	X	X	X	X	X	X
25	543-222BX	Intake Blank-Off Plate	0	0	0	0	0	0	0	0
26	543-220BX	Exhaust Blank-Off Plate	X	X	X	X	X	X	X	X
27	543-248-*BX ①	Access Cover	X	X	X	X	X	X	X	X
27	543-250BX ②	Access Cover	0	0	0	0	0	0	0	0
27	543-251BX ③	Access Cover	0	0	0	0	0	0	0	0
28	5252-033BX	Bard Nameplate	X	X	X	X	X	X	X	X

- ① Exterior cabinet parts are manufactured with various paint color options. To ensure the proper paint color is received, include the complete model and serial number of the unit for which cabinet parts are being ordered.
- ② Exterior cabinet parts are manufactured from aluminum Code "A"
NOTE: #24 - Top rain flashing not available in aluminum; order 113-150-4 (Gray).
- ③ Exterior cabinet parts are manufactured from stainless steel Code "S"

X – Standard Component
O – Optional Component

Refer to drawing on page 4

This page intentionally left blank

EXTERNAL PARTS - RECESSED CABINET

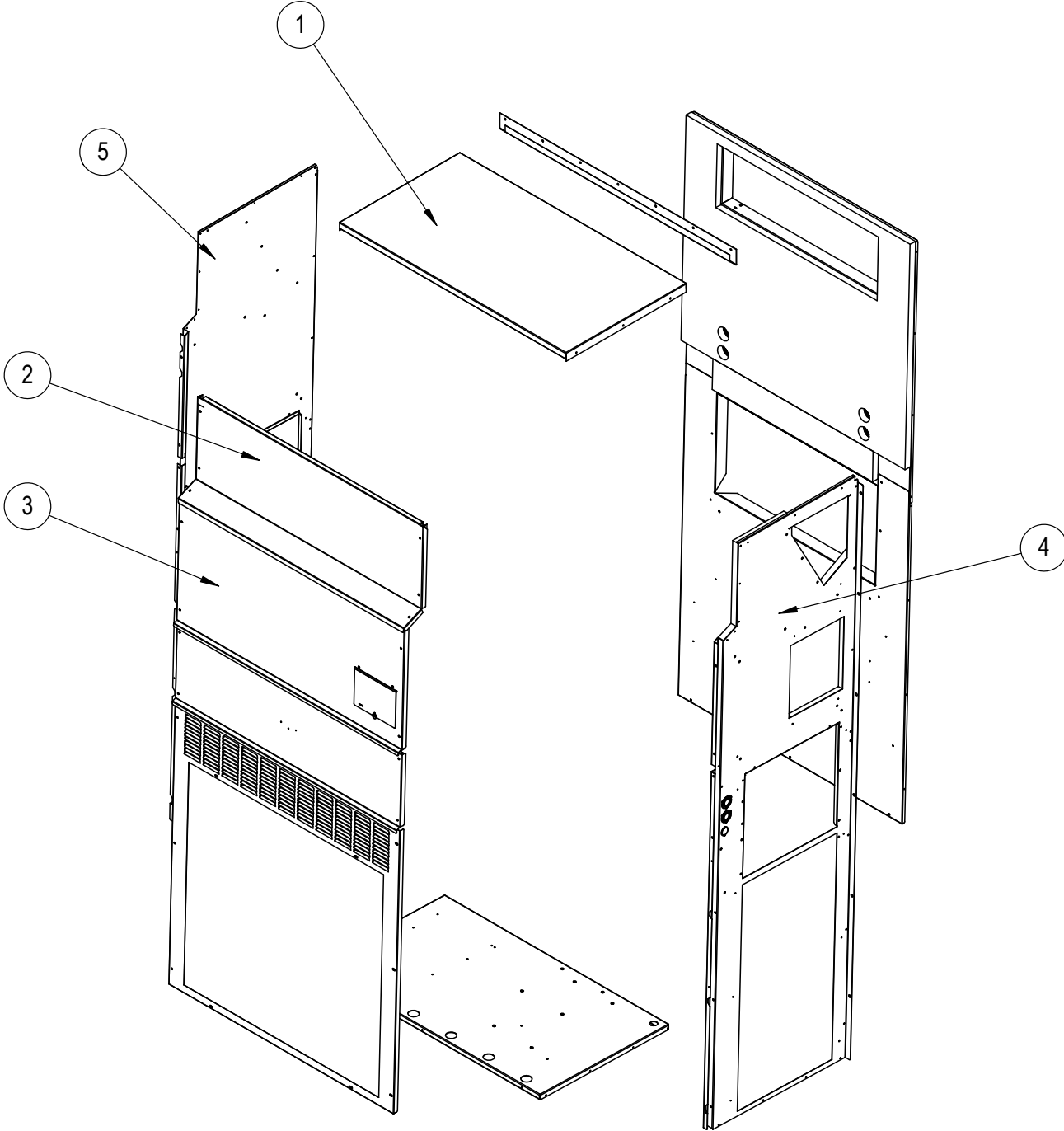

SEXP-1088

EXTERNAL PARTS – RECESSED CABINET

For CABINET & CONDENSER FAN character J or N only (refer to page 2)

Drawing No.	Part Number	Description	C36HF-A, B, C	C42HF-A, B, C	C48HF-A, B, C	C60HF-A, B, C
1	507-413-*BX ①	Top	X	X	X	X
2	515-354-*BX ①	Upper Front	X	X		
2	515-356-*BX ①	Upper Front			X	X
3	515-355-*BX ①	Center Front	X	X		
3	515-357-*BX ①	Center Front			X	X
4	501-1142-*BX ①	Right Side Assembly	X	X		
4	501-1144-*BX ①	Right Side Assembly			X	X
5	501-1143-*BX ①	Left Side Assembly	X	X		
5	501-1145-*BX ①	Left Side Assembly			X	X

- ① Exterior cabinet parts are manufactured with various paint color options. To ensure the proper paint color is received, include the complete model and serial number of the unit for which cabinet parts are being ordered.

NOTE: The replacement cabinet parts listed above are specific to the **recessed unit C36/42/48/60HF heat pump models**. All other replacement cabinet external parts for these models are referenced on pages 4, 5 and 6.

INTERNAL PARTS – STANDARD & DEHUMIDIFICATION

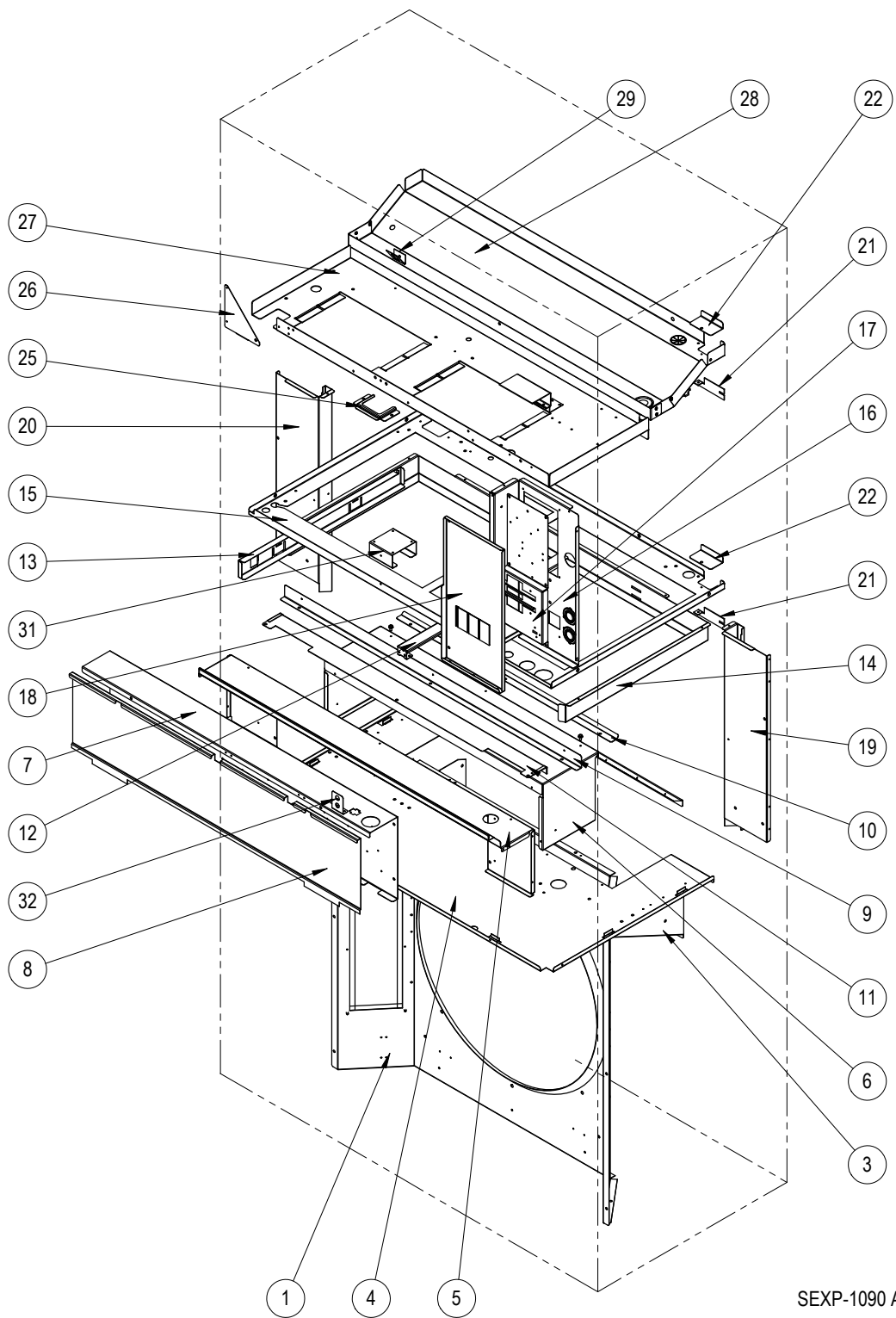

This drawing to be used for reference for pages 11 and 12

INTERNAL PARTS – STANDARD & DEHUMIDIFICATION

Dwg. No.	Part Number	Description	C36HF-A, B	C36HF-C	C42HF-A, B	C42HF-C	C36HFDA, B	C36HFDC	C42HFDA, B	C42HFDC
Reference CABINET & CONDENSER FAN on page 2										
1	921-0120BX	Fan Shroud - Draw Thru (Character D or N)	X	X	X	X	X	X	X	X
1	921-0122BX	Fan Shroud - Blow Thru (Character X or J)	X	X	X	X	X	X	X	X
1	921-0124BX	Fan Shroud - Draw Thru - Stainless (Character D or N)	O	O	O	O	O	O	O	O
1	921-0126BX	Fan Shroud - Blow Thru - Stainless (Character X or J)	O	O	O	O	O	O	O	O
3	121-586BX	Condenser Partition Insert	X	X	X	X	X	X	X	X
3	121-600BX	Condenser Partition Insert - Stainless	O	O	O	O	O	O	O	O
4	121-585BX	Condenser Partition	X	X	X	X	X	X	X	X
4	121-599BX	Condenser Partition - Stainless	O	O	O	O	O	O	O	O
5	521-630BX	Front Exhaust Partition	X	X	X	X	X	X	X	X
6	521-587BX	Exhaust Partition	X	X	X	X	X	X	X	X
7	Control Panel Assy.	See Control Panel beginning on page 20	X	X	X	X	X	X	X	X
8	133-330BX	Control Panel Cover (Inner)	X	X	X	X	X	X	X	X
9	105-1453BX	Front Vent Guide Rail	X	X	X	X	X	X	X	X
10	105-1452BX	Vent Guide Rail	X	X	X	X	X	X	X	X
11	135-409BX	Field Wire Shield	X	X	X	X	X	X	X	X
12	131-168BX	Filter Support Bracket	X	X	X	X	X	X	X	X
13	131-170BX	Filter Slide	X	X	X	X	X	X	X	X
14	131-169BX	Filter Rack Frame	X	X	X	X	X	X	X	X
15	121-583BX	Filter Partition	X	X	X	X	X	X	X	X
16	117-412BX	Upper Control Panel	X	X	X	X	X	X	X	X
17	127-575BX	Circuit Breaker Base - 230V	X		X		X		X	
17	127-585BX	Circuit Breaker Base - 460V		X		X		X		X
18	133-303BX	Upper Control Panel Cover	X		X		X		X	
18	133-304BX	Upper Control Panel Cover		X		X		X		X
19	135X393BX	Right Copper Chase	X	X	X	X	X	X	X	X
19	135-397BX	Right Copper Chase - Stainless	O	O	O	O	O	O	O	O
20	135Y393BX	Left Copper Chase	X	X	X	X	X	X	X	X
20	135-398BX	Left Copper Chase - Stainless	O	O	O	O	O	O	O	O
21	113-796BX	Copper Retainer					2	2	2	2
22	137-920BX	Copper Fill Plate	2	2	2	2				
25	113-765BX	Grommet Retainer Bracket	X	X	X	X	X	X	X	X
26	141-492BX	Blower Partition Support	X	X	X	X	X	X	X	X
27	121-582BX	Blower Partition	X	X	X	X	X	X	X	X
28	523-161BX	Drain Pan Assembly	X	X	X	X	X	X	X	X
28	523-162BX	Drain Pan Assembly - Stainless	O	O	O	O	O	O	O	O
29	113-967BX	TXV Bracket	X	X	X	X		X	X	X
29	113-768BX	EEV Mounting Bracket					X	X	X	X
31	113-788BX	Filter Switch Bracket	O	O	O	O	O	O	O	O
32	113-789BX	Filter Switch Light Bracket	O	O	O	O	O	O	O	O
NS	113-324BX	Transformer Mounting Plate		X		X		X		X
NS	113-381BX	TXV Bulb Bracket	X	X	X	X				
NS	113-809BX	Heating Expansion Valve Bracket	X	X	X	X				

NS = Not Shown

X – Standard Component
O – Optional Component

INTERNAL PARTS – STANDARD & DEHUMIDIFICATION

Dwg. No.	Part Number	Description	C48HF-A, B	C48HF-C	C60HF-A, B	C60HF-C	C48HFDA, B	C48HFDC	C60HFDA, B	C60HFDC
Reference CABINET & CONDENSER FAN on page 2										
1	921-0121BX	Fan Shroud - Draw Thru (Character D or N)	X	X	X	X	X	X	X	X
1	921-0123BX	Fan Shroud - Blow Thru (Character X or J)	X	X	X	X	X	X	X	X
1	921-0125BX	Fan Shroud - Draw Thru - Stainless (Character D or N)	O	O	O	O	O	O	O	O
1	921-0127BX	Fan Shroud - Blow Thru - Stainless (Character X or J)	O	O	O	O	O	O	O	O
3	121-586BX	Condenser Partition Insert	X	X	X	X	X	X	X	X
3	121-600BX	Condenser Partition Insert - Stainless	O	O	O	O	O	O	O	O
4	121-585BX	Condenser Partition	X	X	X	X	X	X	X	X
4	121-599BX	Condenser Partition - Stainless	O	O	O	O	O	O	O	O
5	521-630BX	Front Exhaust Partition	X	X	X	X	X	X	X	X
6	521-587BX	Exhaust Partition	X	X	X	X	X	X	X	X
7	Control Panel Assy.	See Control Panel beginning on page 20	X	X	X	X	X	X	X	X
8	133-330BX	Control Panel Cover (Inner)	X	X	X	X	X	X	X	X
9	105-1453BX	Front Vent Guide Rail	X	X	X	X	X	X	X	X
10	105-1452BX	Vent Guide Rail	X	X	X	X	X	X	X	X
11	135-409BX	Field Wire Shield	X	X	X	X	X	X	X	X
12	131-168BX	Filter Support Bracket	X	X	X	X	X	X	X	X
13	131-170BX	Filter Slide	X	X	X	X	X	X	X	X
14	131-169BX	Filter Rack Frame	X	X	X	X	X	X	X	X
15	121-583BX	Filter Partition	X	X	X	X	X	X	X	X
16	117-412BX	Upper Control Panel	X	X	X	X	X	X	X	X
17	127-575BX	Circuit Breaker Base - 230V	X		X		X		X	
17	127-585BX	Circuit Breaker Base - 460V		X		X		X		X
18	133-303BX	Upper Control Panel Cover	X		X		X		X	
18	133-304BX	Upper Control Panel Cover		X		X		X		X
19	135X393BX	Right Copper Chase	X	X	X	X	X	X	X	X
19	135-397BX	Right Copper Chase - Stainless	O	O	O	O	O	O	O	O
20	135Y393BX	Left Copper Chase	X	X	X	X	X	X	X	X
20	135-398BX	Left Copper Chase - Stainless	O	O	O	O	O	O	O	O
21	113-796BX	Copper Retainer					2	2	2	2
22	137-920BX	Copper Fill Plate	2	2	2	2				
25	113-765BX	Grommet Retainer Bracket	X	X	X	X	X	X	X	X
26	141-492BX	Blower Partition Support	X	X	X	X	X	X	X	X
27	121-582BX	Blower Partition	X	X	X	X	X	X	X	X
28	523-161BX	Drain Pan Assembly	X	X	X	X	X	X	X	X
28	523-162BX	Drain Pan Assembly - Stainless	O	O	O	O	O	O	O	O
29	113-967BX	TXV Bracket	X	X	X	X				
29	113-768BX	EEV Mounting Bracket					X	X	X	X
31	113-788BX	Filter Switch Bracket	O	O	O	O	O	O	O	O
32	113-789BX	Filter Switch Light Bracket	O	O	O	O	O	O	O	O
NS	113-324BX	Transformer Mounting Plate		X		X		X		X
NS	113-381BX	TXV Bulb Bracket	X	X	X	X				
NS	113-809BX	Heating Expansion Valve Bracket	X	X	X	X				

NS = Not Shown

X – Standard Component
O – Optional Component

This page intentionally left blank

FUNCTIONAL COMPONENTS – STANDARD & DEHUMIDIFICATION

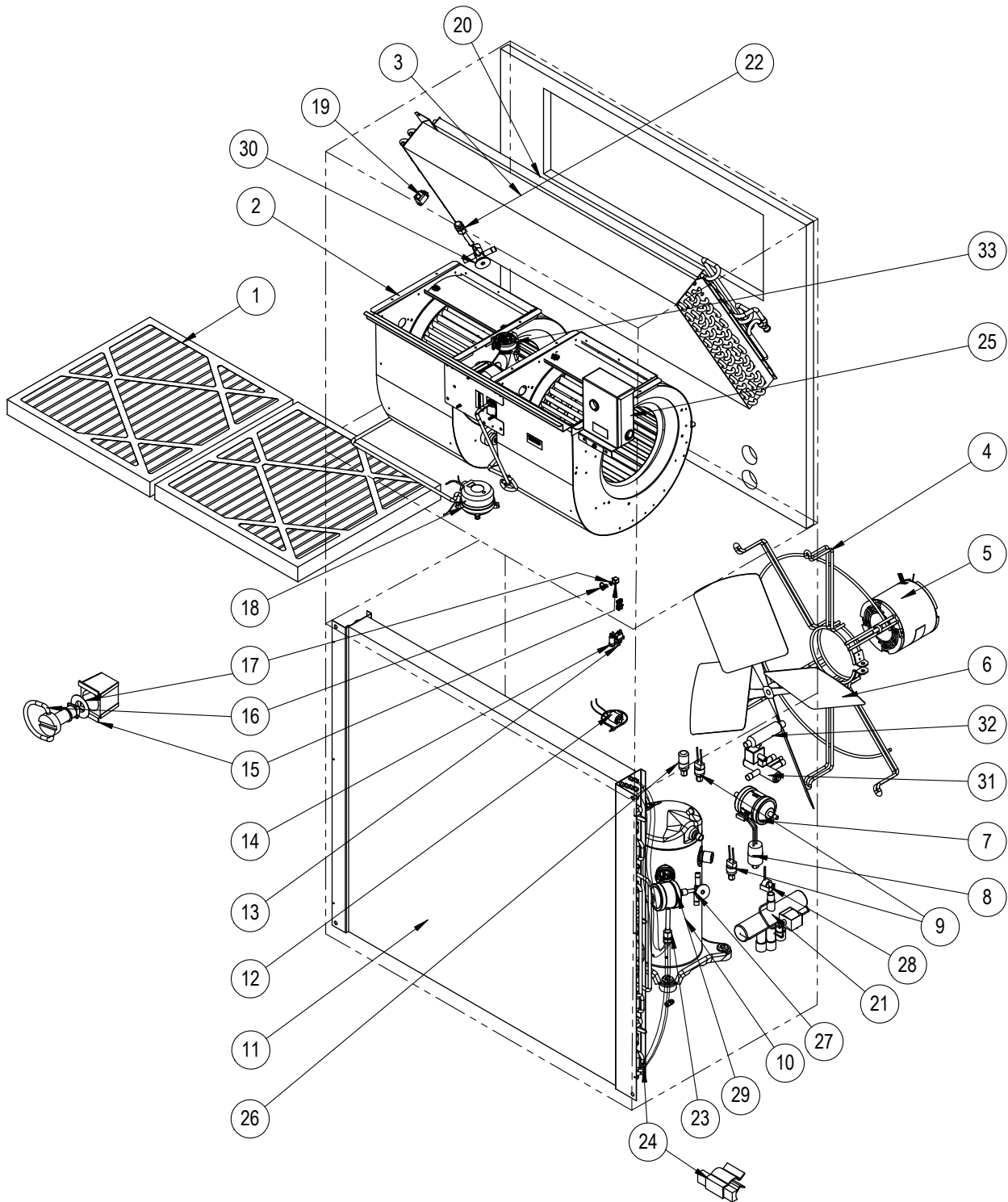

SEXP-1089 A

This drawing to be used for reference for pages 15, 16, 17 and 18

FUNCTIONAL COMPONENTS – STANDARD & DEHUMIDIFICATION

Dwg. No.	Part Number	Description	C36HF-A	C36HF-B	C36HF-C	C42HF-A	C42HF-B	C42HF-C	C36HFDA	C36HFDB	C36HFDC	C42HFDA	C42HFDB	C42HFDC
1	7004-012	Air Filter 1" Throw-Away (20 x 20 x 1)	2	2	2	2	2	2	2	2	2	2	2	2
1	7003-085 ①	Air Filter 1" Washable (20 x 20 x 1)	2	2	2	2	2	2	2	2	2	2	2	2
1	7004-052 ①	Air Filter 2" Merv 8 (20 x 20 x 2)	2	2	2	2	2	2	2	2	2	2	2	2
1	7004-060 ①	Air Filter 2" Merv 11 (20 x 20 x 2)	2	2	2	2	2	2	2	2	2	2	2	2
1	7004-063 ①	Air Filter 2" Merv 13 (20 x 20 x 2)	2	2	2	2	2	2	2	2	2	2	2	2
2	900-398-0237BX	Blower Assembly	X	X	X				X	X	X			
2	900-398-0238BX	Blower Assembly				X	X	X				X	X	X
3	917-0405BX	Indoor Coil w/Distributor Assy.	X	X	X				X	X	X			
3	917-0406BX	Indoor Coil - Coated w/Distributor Assy.	O	O	O				O	O	O			
3	917-0409BX	Indoor Coil w/Distributor Assy.				X	X	X				X	X	X
3	917-0410BX	Indoor Coil - Coated w/Distributor Assy..				O	O	O				O	O	O
4	8200-049BX	Fan Motor Mount	X	X	X	X	X	X	X	X	X	X	X	X
4	8200-052BX	Fan Motor Mount - Stainless Steel	O	O	O	O	O	O	O	O	O	O	O	O
5	8105-078BX	Condenser Motor - 230V	X	X		X	X		X	X		X	X	
5	8105-071BX	Condenser Motor - 460V			X			X			X			X
Reference CABINET & CONDENSER FAN on page 2														
6	5151-054BX	Fan Blade - Draw Thru (Character D or N)	X	X	X	X	X	X	X	X	X	X	X	X
6	5151C054BX	Fan Blade - Draw Thru - Coated (Character D or N)	O	O	O	O	O	O	O	O	O	O	O	O
6	5151-060BX	Fan Blade - Blow Thru (Character X or J)	X	X	X	X	X	X	X	X	X	X	X	X
6	5151C060BX	Fan Blade - Blow Thru - Coated (Character X or J)	O	O	O	O	O	O	O	O	O	O	O	O
7	5201-020BX	H/P Liquid Filter Drier	X	X	X	X	X	X	X	X	X	X	X	X
8	8406-105BX	Low Ambient Control (LAC)	O	O	O	O	O	O	O	O	O	O	O	O
9	8406-167BX	High Pressure Switch	X	X	X	X	X	X	X	X	X	X	X	X
9	8406-168BX	Low Pressure Switch	X	X	X	X	X	X	X	X	X	X	X	X
10	8000-518BX	Compressor YAS30K1E-PFV-ASE	X						X					
10	8000-519BX	Compressor YAS30K1E-TF5-ASE		X						X				
10	8000-520BX	Compressor YAS30K1E-TFD-ASE			X						X			
10	8000-521BX	Compressor YAS35K1E-PFV-ASE				X						X		
10	8000-522BX	Compressor YAS35K1E-TF5-ASE					X						X	
10	8000-523BX	Compressor YAS35K1E-TFD-ASE						X						X
11	917-0413BX	Outdoor Coil (Includes Distributor)	X	X	X				X	X	X			
11	917-0414BX	Outdoor Coil - Coated (Includes Distributor)	O	O	O				O	O	O			
11	917-0415BX	Outdoor Coil (Includes Distributor)				X	X	X				X	X	X
11	917-0416BX	Outdoor Coil - Coated (Includes Distributor)				O	O	O				O	O	O
13	3000-1638BX	Dirty Filter Reset Switch	O	O	O	O	O	O	O	O	O	O	O	O
14	8611-094BX	Red Indicator Light - 24VAC	O	O	O	O	O	O	O	O	O	O	O	O
15	1171-023	1/4 Turn Receptacle	X	X	X	X	X	X	X	X	X	X	X	X
16	1171-022	1/4 Turn Fastener	X	X	X	X	X	X	X	X	X	X	X	X
17	1171-024	1/4 Turn Retainer	X	X	X	X	X	X	X	X	X	X	X	X
18	8301-057BX	Filter Pressure Switch	O	O	O	O	O	O	O	O	O	O	O	O
19	CMC-29	Freeze Protection Thermostat	O	O	O	O	O	O	O	O	O	O	O	O
20	5051-221BX	Reheat Coil							X	X	X	X	X	X
20	5054-221BX	Reheat Coil - Coated							O	O	O	O	O	O
21	5650-040BX	Reversing Valve	X	X	X	X	X	X	X	X	X	X	X	X
22	800-0461BX	Distributor Assembly - Indoor Coil	X	X	X				X	X	X			
22	800-0424BX	Distributor Assembly - Indoor Coil				X	X	X				X	X	X
23	800-0424BX	Distributor Assembly - Outdoor Coil	X	X	X				X	X	X			
23	800-0467BX	Distributor Assembly - Outdoor Coil				X	X	X				X	X	X

Continued on page 16

① – Optional on these models

X – Standard Component
O – Optional Component

FUNCTIONAL COMPONENTS – STANDARD & DEHUMIDIFICATION

Dwg. No.	Part Number	Description	C36HF-A	C36HF-B	C36HF-C	C42HF-A	C42HF-B	C42HF-C	C36HFDA	C36HFDB	C36HFDC	C42HFDA	C42HFDB	C42HFDC
<i>Continued from page 15</i>														
24	8620-225	Defrost Thermistor Sensor	X	X	X	X	X	X	X	X	X	X	X	X
25	910-2050-005	EEV Controller (see EEV Controller Assembly on page 27)							X	X	X	X	X	X
26	8406-158BX	Low Pressure Transducer							X	X	X	X	X	X
27	5651-253BX	Heating Expansion Valve	X	X	X									
27	5651-262BX	Heating Expansion Valve				X	X	X						
28	8408-039BX	Discharge Line Thermostat	X	X	X	X	X	X						
29	5220-013BX	Pulsation Dampener/Muffler	X	X	X	X	X	X	X	X	X	X	X	X
30	5651-262BX	Cooling Expansion Valve	X	X	X	X	X	X						
30	905-0737BX	EEV Valve Assembly							X	X	X	X	X	X
31	5650-051BX	Dehumidification Valve							X	X	X	X	X	X
32	5651-219BX	Check Valve							2	2	2	2	2	2
33	8301-110BX	RDS Sensor	X	X	X	X	X	X	X	X	X	X	X	X
NS	8401-036BX	RDS Relay	X	X	X	X	X	X	X	X	X	X	X	X
NS	3000-1824BX	RDS Harness	X	X	X	X	X	X	X	X	X	X	X	X
NS	910-2188BX	460V Transformer Assembly			X			X			X			X
NS	CMC-33	Dirty Filter Switch Kit = Item #'s 13,14,18	0	0	0	0	0	0	0	0	0	0	0	0
NS	5650-042BX	Dehum/Rev. Valve Solenoid, Red Casing (Ranco)	X	X	X	X	X	X	X	X	X	X	X	X
NS	5650-046BX	Dehum/Rev. Valve Solenoid, Black Casing (San Hua)	X	X	X	X	X	X	X	X	X	X	X	X
NS	5451-024	Tubing Isolation Grommet	2	2	2	2	2	2	2	2	2	2	2	2
NS	6031-009	Coremax Valve Core	2	2	2	2	2	2	2	2	2	2	2	2
NS	1171-028	Control Panel Door Clip	4	4	4	4	4	4	4	4	4	4	4	4
NS	1171-057	Control Panel Door Screw	4	4	4	4	4	4	4	4	4	4	4	4
NS	1171-027	Control Panel Door Screw Retainer	4	4	4	4	4	4	4	4	4	4	4	4
NS	5650-054	Molded Plug for Rev/Dehum Valves	X	X	X	X	X	X	X	X	X	X	X	X
NS	8620-370	NPBI Kit	0	0	0	0	0	0	0	0	0	0	0	0
NS	8620-343	UVC Kit	0	0	0	0	0	0	0	0	0	0	0	0

NS = Not Shown

X – Standard Component
O – Optional Component

Refer to drawing on page 14

FUNCTIONAL COMPONENTS – STANDARD & DEHUMIDIFICATION

Dwg. No.	Part Number	Description	C48HF-A	C48HF-B	C48HF-C	C60HF-A	C60HF-B	C60HF-C	C48HFDA	C48HFDB	C48HFDC	C60HFDA	C60HFDB	C60HFDC
1	7004-012	Air Filter 1" Throw-Away (20 x 20 x 1)	2	2	2	2	2	2	2	2	2	2	2	2
1	7003-085 ①	Air Filter 1" Washable (20 x 20 x 1)	2	2	2	2	2	2	2	2	2	2	2	2
1	7004-052 ①	Air Filter 2" Merv 8 (20 x 20 x 2)	2	2	2	2	2	2	2	2	2	2	2	2
1	7004-060 ①	Air Filter 2" Merv 11 (20 x 20 x 2)	2	2	2	2	2	2	2	2	2	2	2	2
1	7004-063 ①	Air Filter 2" Merv 13 (20 x 20 x 2)	2	2	2	2	2	2	2	2	2	2	2	2
2	900-397-0239BX	Blower Assembly	X	X	X				X	X	X			
2	900-397-0240BX	Blower Assembly				X	X	X				X	X	X
3	917-0376BX	Indoor Coil w/Distributor Assy.	X	X	X	X	X	X	X	X	X	X	X	X
3	917-0377BX	Indoor Coil - Coated w/Distributor Assy.	0	0	0	0	0	0	0	0	0	0	0	0
4	8200-049BX	Fan Motor Mount	X	X	X	X	X	X	X	X	X	X	X	X
4	8200-052BX	Fan Motor Mount - Stainless Steel	0	0	0	0	0	0	0	0	0	0	0	0
5	8105-078BX	Condenser Motor - 230V	X	X					X	X				
5	8105-071BX	Condenser Motor - 460V			X						X			
5	8106-053-0241BX	Programmed Condenser Motor & Control (230/208V)				X	X					X	X	
5	8106-081-0253BX	Programmed Condenser Motor & Control (460V)						X						X
Reference CABINET & CONDENSER FAN on page 2														
6	5151-054BX	Fan Blade - Draw Thru (Character D or N)	X	X	X	X	X	X	X	X	X	X	X	X
6	5151C054BX	Fan Blade - Draw Thru - Coated (Character D or N)	0	0	0	0	0	0	0	0	0	0	0	0
6	5151-060BX	Fan Blade - Blow Thru (Character X or J)	X	X	X	X	X	X	X	X	X	X	X	X
6	5151C060BX	Fan Blade - Blow Thru - Coated (Character X or J)	0	0	0	0	0	0	0	0	0	0	0	0
7	5201-020BX	H/P Liquid Filter Drier	X	X	X	X	X	X	X	X	X	X	X	X
8	8406-105BX	Low Ambient Control (LAC)	0	0	0	0	0	0	0	0	0	0	0	0
9	8406-167BX	High Pressure Switch	X	X	X	X	X	X	X	X	X	X	X	X
9	8406-168BX	Low Pressure Switch	X	X	X	X	X	X	X	X	X	X	X	X
10	8000-524BX	Compressor YAS40K1E-PFV-ASE	X						X					
10	8000-525BX	Compressor YAS40K1E-TF5-ASE		X						X				
10	8000-526BX	Compressor YAS40K1E-TFD-ASE			X						X			
10	8000-527BX	Compressor YAS51K1E-PFV-ASE				X						X		
10	8000-528BX	Compressor YAS51K1E-TF5-ASE					X						X	
10	8000-529BX	Compressor YAS51K1E-TFD-ASE						X						X
11	917-0417BX	Outdoor Coil (Includes Distributor)	X	X	X	X	X	X	X	X	X	X	X	X
11	917-0418BX	Outdoor Coil - Coated (Includes Distributor)	0	0	0	0	0	0	0	0	0	0	0	0
13	3000-1638BX	Dirty Filter Reset Switch	0	0	0	0	0	0	0	0	0	0	0	0
14	8611-094BX	Red Indicator Light - 24VAC	0	0	0	0	0	0	0	0	0	0	0	0
15	1171-023	1/4 Turn Receptacle	X	X	X	X	X	X	X	X	X	X	X	X
16	1171-022	1/4 Turn Fastener	X	X	X	X	X	X	X	X	X	X	X	X
17	1171-024	1/4 Turn Retainer	X	X	X	X	X	X	X	X	X	X	X	X
18	8301-057BX	Filter Pressure Switch	0	0	0	0	0	0	0	0	0	0	0	0
19	CMC-29	Freeze Protection Thermostat	0	0	0	0	0	0	0	0	0	0	0	0
20	5051-221BX	Reheat Coil							X	X	X	X	X	X
20	5054-221BX	Reheat Coil - Coated							0	0	0	0	0	0
21	5650-040BX	Reversing Valve	X	X	X	X	X	X	X	X	X	X	X	X
22	800-0455BX	Distributor Assembly - Indoor Coil	X	X	X	X	X	X	X	X	X	X	X	X
23	800-0455BX	Distributor Assembly - Outdoor Coil	X	X	X	X	X	X	X	X	X	X	X	X
24	8620-225	Defrost Thermistor Sensor	X	X	X	X	X	X						

Continued on page 18

① – Optional on these models

X – Standard Component
0 – Optional Component

Refer to drawing on page 14

FUNCTIONAL COMPONENTS – STANDARD & DEHUMIDIFICATION

Dwg. No.	Part Number	Description	C48HF-A	C48HF-B	C48HF-C	C60HF-A	C60HF-B	C60HF-C	C48HFDA	C48HFDB	C48HFDC	C60HFDA	C60HFDB	C60HFDC
<i>Continued from page 17</i>														
25	910-2050-006	EEV Controller (see EEV Controller Assembly on page 27)							X	X	X	X	X	X
26	8406-158BX	Low Pressure Transducer							X	X	X	X	X	X
27	5651-263BX	Heating Expansion Valve	X	X	X	X	X	X						
28	8408-039BX	Discharge Line Thermostat	X	X	X	X	X	X	X	X	X	X	X	X
29	5220-013BX	Pulsation Dampener/Muffler	X	X	X	X	X	X	X	X	X	X	X	X
30	5651-263BX	Cooling Expansion Valve	X	X	X	X	X	X						
30	905-0737BX	EEV Valve Assembly							X	X	X			
30	905-0745BX	EEV Valve Assembly										X	X	X
31	5650-051BX	Dehumidification Valve							X	X	X	X	X	X
32	5651-219BX	Check Valve							2	2	2	2	2	2
33	8301-110BX	RDS Sensor	X	X	X	X	X	X	X	X	X	X	X	X
NS	8401-036BX	RDS Relay	X	X	X	X	X	X	X	X	X	X	X	X
NS	3000-1824BX	RDS Harness	X	X	X	X	X	X	X	X	X	X	X	X
NS	910-2188BX	460V Transformer Assembly			X						X			
NS	910-2220BX	460V Transformer Assembly					X							X
NS	CMC-33	Dirty Filter Switch Kit = Item #'s 13,14,18	0	0	0	0	0	0	0	0	0	0	0	0
NS	5650-042BX	Dehum/Rev. Valve Solenoid, Red Casing (Ranco)	X	X	X	X	X	X	X	X	X	X	X	X
NS	5650-046BX	Dehum/Rev. Valve Solenoid, Black Casing (San Hua)	X	X	X	X	X	X	X	X	X	X	X	X
NS	5451-024	Tubing Isolation Grommet	2	2	2	2	2	2	2	2	2	2	2	2
NS	6031-009	Coremax Valve Core	2	2	2	2	2	2	2	2	2	2	2	2
NS	1171-028	Control Panel Door Clip	4	4	4	4	4	4	4	4	4	4	4	4
NS	1171-057	Control Panel Door Screw	4	4	4	4	4	4	4	4	4	4	4	4
NS	1171-027	Control Panel Door Screw Retainer	4	4	4	4	4	4	4	4	4	4	4	4
NS	5650-054	Molded Plug for Rev/Dehum Valves	X	X	X	X	X	X	X	X	X	X	X	X
NS	8620-370	NPBI Kit	0	0	0	0	0	0	0	0	0	0	0	0
NS	8620-343	UVC Kit	0	0	0	0	0	0	0	0	0	0	0	0

NS = Not Shown

X – Standard Component
O – Optional Component

Refer to drawing on page 14

This page intentionally left blank

CONTROL PANEL – 230V 1PH & 230V 3PH

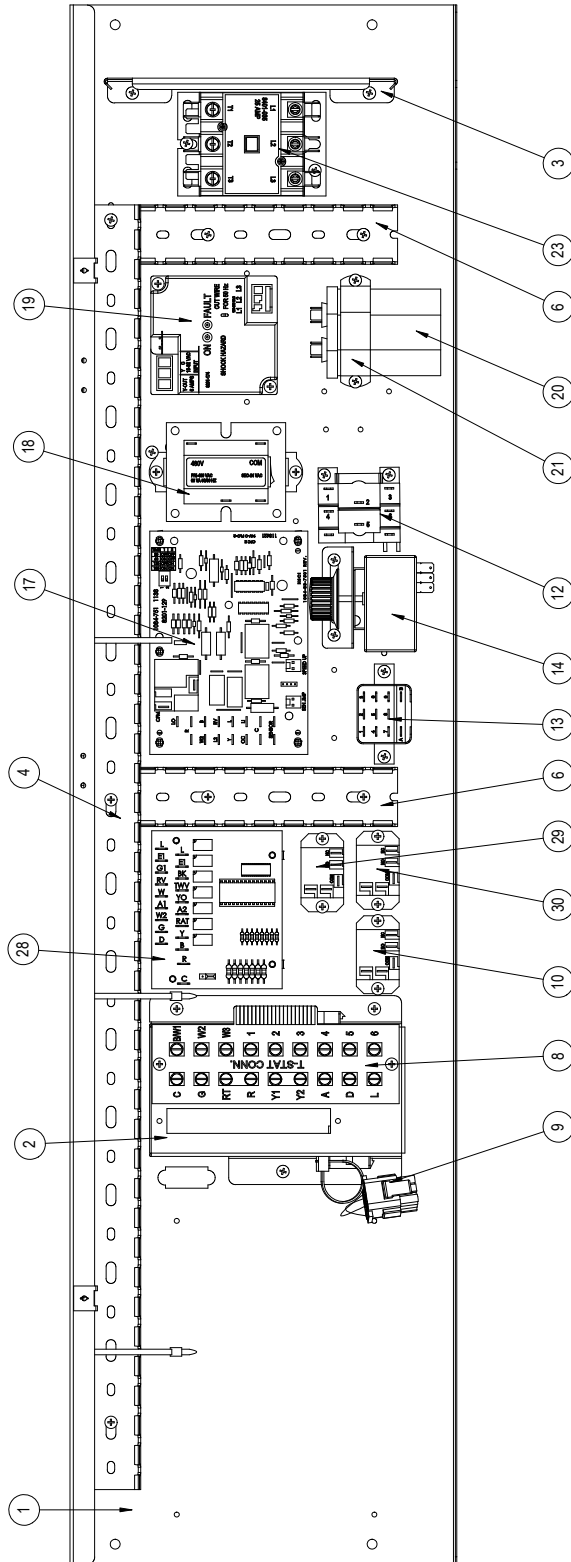

SEXP-1131

This drawing to be used for reference for pages 21 and 22

CONTROL PANEL – 230V 1PH & 230V 3PH

Dwg. No.	Part Number	Description	C36HF-A	C36HF-B	C42HF-A	C42HF-B	C48HF-A	C48HF-B	C60HF-A	C60HF-B	C36HFDA	C36HFDB	C42HFDA	C42HFDB	C48HFDA	C48HFDB	C60HFDA	C60HFDB
1	117-456BX	Control Panel	X	X	X	X	X	X	X	X	X	X	X	X	X	X	X	X
2	910-2206BX	Complete Low Voltage Box Assembly (Sheet metal, Terminal Strip & Wire Harness)	X	X	X	X	X	X	X	X	X	X	X	X	X	X	X	X
3	135-394BX	Wire Shield	X	X	X	X	X	X	X	X	X	X	X	X	X	X	X	X
4	8611-244-3208	Cable Duct - 32.5"	X	X	X	X	X	X	X	X	X	X	X	X	X	X	X	X
6	8611-244-0608	Cable Duct - 6.5"	2	2	2	2	2	2	2	2	2	2	2	2	2	2	2	2
8	8607-063BX	Low Voltage Terminal Strip - 18 Terminal	X	X	X	X	X	X	X	X	X	X	X	X	X	X	X	X
9	3000-1524BX	Vent Jumper Plug (used when no vent option)	X	X	X	X	X	X	X	X	X	X	X	X	X	X	X	X
10	8201-130BX	Alarm Relay (Kit = CMC-35)	0	0	0	0	0	0	0	0	0	0	0	0	0	0	0	0
12	8201-086BX	OD T-Stat/LAC Relay (LAC Kit = CMH-35)	0	0	0	0	0	0	0	0	0	0	0	0	0	0	0	0
13	8201-159BX	Dirty Filter Relay (Kit = CMC-33)	0	0	0	0	0	0	0	0	0	0	0	0	0	0	0	0
14	8408-028BX	Outdoor Thermostat (ODT Kit = CMH-36)	0	0	0	0	0	0	0	0	0	0	0	0	0	0	0	0
17	8620-223	Defrost Logic Control Board w/Sensor	X	X	X	X	X	X	X	X	X	X	X	X	X	X	X	X
18	8407-065BX	Transformer 208/240-24VAC 75VA	X	X	X	X	X	X	X	X	X	X	X	X	X	X	X	X
19	8201-174BX	3 Phase Line Monitor 50/60Hz		X		X		X		X		X		X		X		X
20	8552-005BX	Capacitor 10MFD 370V 1-1/4" O		X		X		X				X		X		X		
20	8552-055BX	Capacitor 40/10 MFD 440V					X								X			
20	8552-079BX	Capacitor 45/10 MFD 370V 2.5" R	X								X							
20	8552-080BX	Capacitor 40/10 MFD 370V 2.0" R			X								X					
20	8552-096BX	Capacitor 40MFD 440V 2" R							X								X	
21	8550-003BX	Capacitor Bracket 1-1/4" Oval		X		X		X				X		X		X		
21	8550-007BX	Capacitor Bracket 2" Round							X								X	
21	8550-008BX	Capacitor Bracket 2-1/2" Round	X		X		X				X		X		X			
23	8401-035BX	Contactor 3-Pole 25 Amp		X		X		X		X		X		X		X		X
23	8401-034BX	Contactor 2-Pole 40 Amp	X		X		X		X		X		X		X		X	
NS	8201-130BX	Outdoor Fan Relay (located where 3 phase monitor or capacitor device shown)							X	X							X	X
28	8201-113BX	Dehum Logic Board									X	X	X	X	X	X	X	X
29	8201-130BX	Dehum Control Relay									X	X	X	X	X	X	X	X
30	8201-130BX	3-Way Valve Control Relay															X	X
NS	8615-037BX	Circuit Breaker 30A 2 Pole ①	0								0							
NS	8615-038BX	Circuit Breaker 35A 2 Pole ①			0		0											
NS	8615-055BX	Circuit Breaker 40A 2 Pole ①											0		0			
NS	8615-040BX	Circuit Breaker 50A 2 Pole ①							0								0	
NS	8615-051BX	Circuit Breaker 25A 3 Pole ①		0		0						0						
NS	8615-052BX	Circuit Breaker 30A 3 Pole ①						0					0		0			
NS	8615-042BX	Circuit Breaker 35A 3 Pole ①							0									0
NS	4217-101	Wiring Diagram	X		X		X											
NS	4217-102	Wiring Diagram							X									
NS	4217-103	Wiring Diagram									X		X		X			
NS	4217-104	Wiring Diagram															X	
NS	4217-201	Wiring Diagram		X		X		X										
NS	4217-202	Wiring Diagram							X									
NS	4217-203	Wiring Diagram									X		X		X			
NS	4217-204	Wiring Diagram																X

Continued on page 22

NS = Not Shown

① Circuit breakers listed are for units without electric heat, "OZ" models.
See heater replacement parts manual for units with electric heat.

X – Standard Component

O – Optional Component

CONTROL PANEL – 230V 1PH & 230V 3PH

Dwg. No.	Part Number	Description	C36HF-A	C36HF-B	C42HF-A	C42HF-B	C48HF-A	C48HF-B	C60HF-A	C60HF-B	C36HFDA	C36HFDB	C42HFDA	C42HFDB	C48HFDA	C48HFDB	C60HFDA	C60HFDB
<i>Continued from page 21</i>																		
NS	3000-1706BX	Blower Power Plug	X	X	X	X	X	X	X	X	X	X	X	X	X	X	X	X
NS	3000-1732BX	Blower Speed Plug	X	X	X	X	X	X	X	X	X	X	X	X	X	X	X	X
NS	3000-1222BX	Compressor Plug/Harness	X		X		X		X		X		X		X		X	
NS	3000-1230BX	Compressor Plug/Harness		X		X		X		X		X		X		X		X
NS	3000-1223BX	Compressor Plug/Harness - Stage 2 Plug	X	X	X	X	X	X	X	X	X	X	X	X	X	X	X	X
NS	3003-178BX	Control Panel Wire Harness	X		X		X											
NS	3003-179BX	Control Panel Wire Harness		X		X		X										
NS	3003-181BX	Control Panel Wire Harness									X		X		X			
NS	3003-182BX	Control Panel Wire Harness										X		X		X		
NS	3003-184BX	Control Panel Wire Harness							X									
NS	3003-185BX	Control Panel Wire Harness								X								
NS	3003-186BX	Control Panel Wire Harness															X	
NS	3003-187BX	Control Panel Wire Harness																X
NS	8551-004BX	Start Device (PTCR) (Kit = CMC-32)	O		O		O		O		O		O		O		O	
NS	3000-1693BX	Low Voltage Terminal Block Wire Harness	X	X	X	X	X	X	X	X	X	X	X	X	X	X	X	X

NS = Not Shown

X – Standard Component
O – Optional Component

Refer to drawing on page 20

This page intentionally left blank

CONTROL PANEL - 460V 3PH

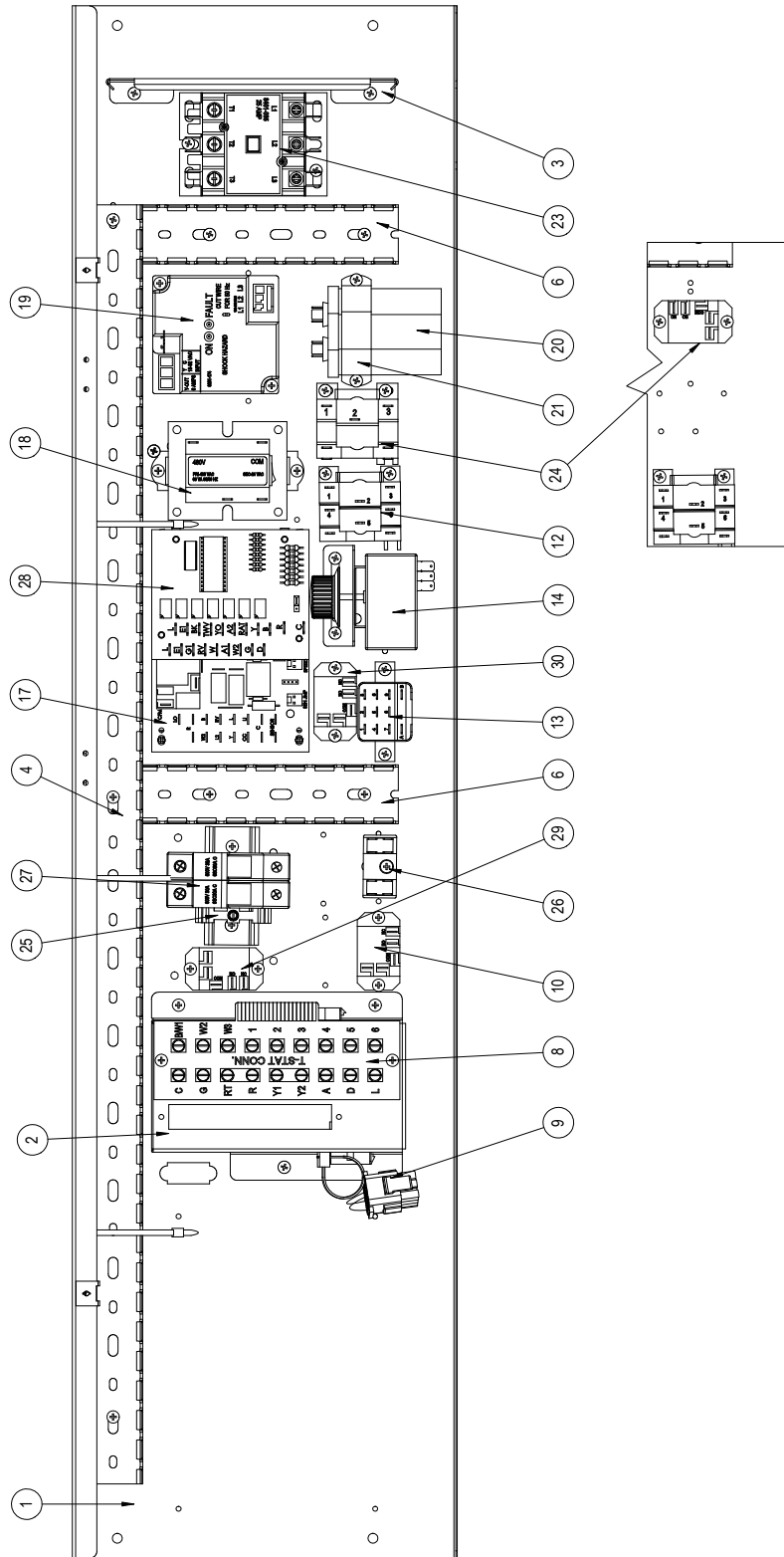

SEXP-1132

This drawing to be used for reference for pages 25 and 26

CONTROL PANEL – 460V 3PH

Dwg. No.	Part Number	Description	C36HF-C	C42HF-C	C48HF-C	C60HF-C	C36HFDC	C42HFDC	C48HFDC	C60HFDC
1	117-456BX	Control Panel	X	X	X	X	X	X	X	X
2	910-2206BX	Complete Low Voltage Box Assembly (Sheet metal, Terminal Strip & Wire Harness)	X	X	X	X	X	X	X	X
3	135-394BX	Wire Shield	X	X	X	X	X	X	X	X
4	8611-244-3208	Cable Duct - 32.5"	X	X	X	X	X	X	X	X
6	8611-244-0608	Cable Duct - 6.5"	2	2	2	2	2	2	2	2
8	8607-063BX	Low Voltage Terminal Strip - 18 Terminal	X	X	X	X	X	X	X	X
9	3000-1524BX	Vent Jumper Plug (used when no vent option)	X	X	X	X	X	X	X	X
10	8201-130BX	Alarm Relay (Kit = CMC-35)	0	0	0	0	0	0	0	0
12	8201-086BX	OD T-Stat/LAC Relay (LAC Kit = CMH-35)	0	0	0	0	0	0	0	0
13	8201-159BX	Dirty Filter Relay (Kit = CMC-33)	0	0	0	0	0	0	0	0
14	8408-028BX	Outdoor Thermostat (ODT Kit = CMH-36)	0	0	0	0	0	0	0	0
17	8620-223	Defrost Logic Control Board w/Sensor	X	X	X	X	X	X	X	X
18	8407-050BX	Transformer 480/24VAC 75VA	X	X	X	X	X	X	X	X
19	8201-174BX	3 Phase Line Monitor 50/60Hz	X	X	X	X	X	X	X	X
20	8552-004BX	Capacitor 7-1/2MFD 370V 1-1/4" O	X	X	X		X	X	X	
21	8550-003BX	Capacitor Bracket 1-1/4" Oval	X	X	X		X	X	X	
23	8401-035BX	Contacto 3-Pole 25 Amp	X	X	X	X	X	X	X	X
24	8201-032BX	Outdoor Fan Relay	X	X	X		X	X	X	
24	8201-130BX	Outdoor Fan Relay (located where capacitor device shown)				X				X
25	8611-144BX	End Clamp for DIN Rail	X	X	X	X	X	X	X	X
26	8607-017BX	Terminal Block 240V 2 Terminal	X	X	X	X	X	X	X	X
27	8614-058BX	2-Pole Enclosed Fuse Holder	X	X	X	X	X	X	X	X
28	8201-113BX	Dehum Logic Board					X	X	X	X
29	8201-130BX	Dehum Control Relay					X	X	X	X
30	8201-130BX	3-Way Valve Control Relay								X
NS	8615-095BX	Toggle Disconnect	0	0	0	0	0	0	0	0
NS	8615-096BX	Disconnect Cover	0	0	0	0	0	0	0	0
NS	4217-301	Wiring Diagram	X	X	X					
NS	4217-302	Wiring Diagram				X				
NS	4217-303	Wiring Diagram					X	X	X	
NS	4217-304	Wiring Diagram								X
NS	3000-1706BX	Blower Power Plug	X	X	X	X	X	X	X	X
NS	3000-1732BX	Blower Speed Plug	X	X	X	X	X	X	X	X
NS	3000-1230BX	Compressor Plug/Harness	X	X	X	X	X	X	X	X
NS	3000-1223BX	Compressor Plug/Harness - Stage 2 Plug	X	X	X	X	X	X	X	X
NS	3003-180BX	Control Panel Wire Harness	X	X	X					
NS	3003-183BX	Control Panel Wire Harness					X	X	X	
NS	3003-185BX	Control Panel Wire Harness				X				
NS	3003-188BX	Control Panel Wire Harness								X

Continued on page 26

NS = Not Shown

X – Standard Component
O – Optional Component

CONTROL PANEL – 460V 3PH

Dwg. No.	Part Number	Description	C36HF-C	C42HF-C	C48HF-C	C60HF-C	C36HFDC	C42HFDC	C48HFDC	C60HFDC
<i>Continued from page 25</i>										
NS	3000-1693BX	Low Voltage Terminal Block Wire Harness	X	X	X	X	X	X	X	X
NS	8614-046BX	5A Class CC Fuse (used with Dwg. No. 27)	2	2	2		2			
NS	8614-042BX	7A Class CC Fuse (used with Dwg. No. 27)				2		2	2	2

NS = Not Shown

X – Standard Component
O – Optional Component

Refer to drawing on page 24

EEV CONTROLLER ASSEMBLY

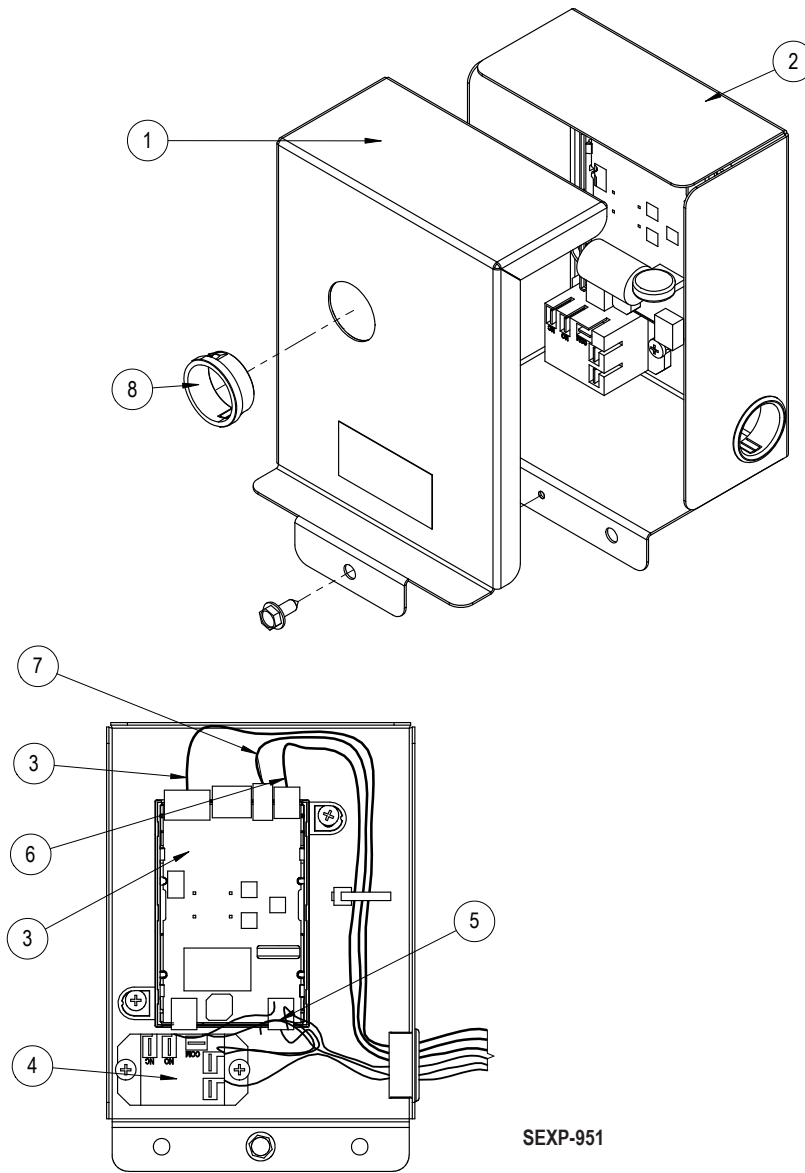

Dwg No.	Part Number	Description	910-2050-005BX	910-2050-006BX
1	143-219BX	EEV Control Box Cover	X	X
2	127-572BX	EEV Control Box	X	X
3	8301-079-0005BX	EEV Control & Stator Cable	X	
3	8301-079-0006BX	EEV Control & Stator Cable		X
3	5651-246BX	EEV Stator Cable Only	X	X
4	8201-130BX	Control Relay	X	X
5	3000-1602BX	Main Wire Assembly	X	X
6	3000-1611BX	Transducer Wire Assembly – Connects to EEV Board	X	X
6	3000-1603BX	Transducer Wire Assembly – Connects to Transducer	X	X
7	8408-056BX	EEV Thermistor	X	X
8	8611-075	Clear Snap Plug	X	X

BLOWER ASSEMBLY

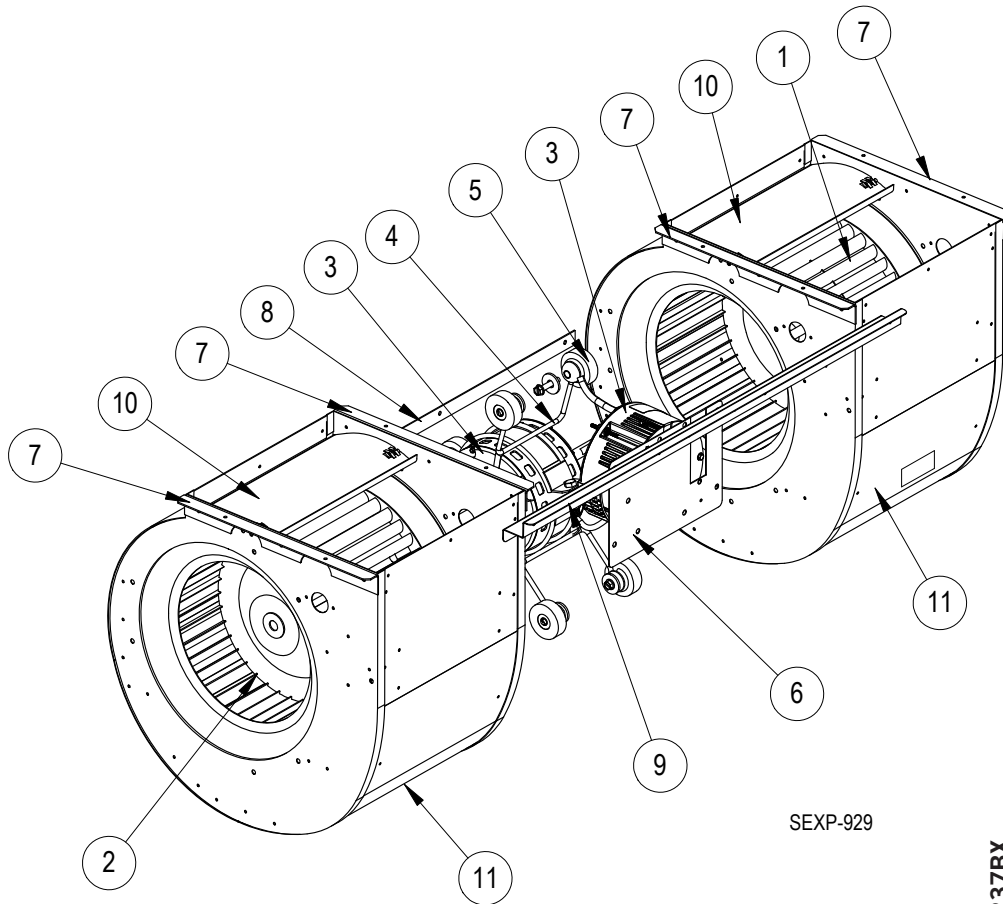

SEXP-929

Dwg No.	Part Number	Description	900-398-0237BX	900-398-0238BX	900-397-0239BX	900-397-0240BX
1	5152-011BX	10 Inch Wheel CW 1/2" 10-8DD	X	X	X	X
2	5152-012BX	10 Inch Wheel CCW 1/2" 10-8DD	X	X	X	X
3	8106-073-0237BX	Programmed Blower Motor & Control (230/208V)	X			
3	8106-073-0238BX	Programmed Blower Motor & Control (230/208V)		X		
3	8107-032-0239BX	Programmed Blower Motor & Control (230/208V)			X	
3	8107-032-0240BX	Programmed Blower Motor & Control (230/208V)				X
3	C8106-073-0237	Programmed Control Only (230/208V)	0			
3	C8106-073-0238	Programmed Control Only (230/208V)		0		
3	C8107-032-0239	Programmed Control Only (230/208V)			0	
3	C8107-032-0240	Programmed Control Only (230/208V)				0
4	8200-040BX	Motor Mount	X	X	X	X
5	5451-011	Grommets	6	6	6	6
6	112-775BX	Motor Control Bracket	X	X	X	X
7	105-880BX	Side Angle	4	4	4	4
8	105-881BX	Back Brace	X	X	X	X
9	103-541BX	Front Mounting Offset	X	X	X	X
10	144-166BX	Diffuser	2	2	2	2
11	151-101BX	Blower Housing	2	2	2	2

X – Standard Component
O – Optional Component



Climate Control Solutions

Limited Warranty

For units applied within the United States, Puerto Rico,
US Virgin Islands, Guam, Canada and Mexico

Limited Warranty To Original Purchaser:

Bard Manufacturing Company, Inc. Bryan, Ohio 43506 warrants to you, the original purchaser, that your Bard product will be free from defects in materials and workmanship when used under normal conditions from the installation date through the time periods outlined in the "Duration of Warranty" section (see reverse side).

Proof Of Purchase:

You must be able to show us the date on which you purchased your product when you make a claim under this warranty. Your owner's registration card filed online at www.wallmountwarranty.com or your contractor's invoice, bill of sale, or similar document is sufficient at time of warranty claim. This must be registered within 90 days of installation. If you can not show us the actual date of purchase, the time periods in this warranty will start on the date that we shipped your Bard product from our factory.

What This Warranty Does Not Cover: (Also see Duration of Warranty on reverse side.)

This warranty does not cover defects or damage caused by:

1. Alterations not approved by Bard; improper installation (including over or under sizing), improper repairs, or servicing; or improper parts and accessories not supplied by Bard.
2. Misuse or failure to follow installation and operating instructions (including failure to perform preventative maintenance) or limitations on the rating plate. This includes failure to use low ambient controls on all applications requiring compressor operation in cooling mode below 60F outdoor ambient.
3. Any corrosion from operation in a corrosive atmosphere (examples: acids, halogenated hydrocarbons or environmental conditions).
4. Parts that must be replaced periodically (such as filters, mist eliminators, ERV belts, pile seals, etc.).
5. Improper fuel or electrical supply (such as low voltage, voltage transients, power interruption, and units on generators with no brownout protection).
6. Accidents or other events beyond our reasonable control (such as storm, fire, or transportation damage).
7. Defects that happen after
 - (a) Anyone has tampered with the product.
 - (b) The product has been improperly serviced according to accepted trade practices;
 - (c) The product has been moved from its original place of installation; or,
 - (d) The product has been damaged by an event beyond Bard's control (See also No. 5 above).
8. Consequential damages (such as increased living expenses while the product is being repaired). Some states do not allow the exclusion or limitation of incidental or consequential damages, so the above limitation or exclusion may not apply to you.
9. This warranty has certain limitations for units installed on over-the-road trucks, vans and trailers. (See reverse side.)
10. Cost of service call at installation site to diagnose causes of trouble, labor to replace defective component or transportation costs for replacement parts.
11. This Limited Warranty does not apply to products installed or operated outside of the US, Puerto Rico, US Virgin Islands, Guam, Canada and Mexico. Units operated in coastal areas where the operating environment is exposed to airborne saline particles (typically 5 miles from coast line) must have corrosion protection or warranty claims will be declined on corrosion-based cabinet and part failures.
12. Bard does not endorse, approve or certify any online sales of its products through auction websites, online retailers, liquidators or any other method of online sales direct to consumers. Bard will not honor the factory warranty of any Bard equipment purchased over the Internet.

Your Responsibilities:

You are responsible for

1. Preventative maintenance of the product (such as cleaning coils and replacement of filters, nozzles and other consumable parts).
2. Ensuring that the instruction manual is followed for care and use of your product.
3. Ensuring that your product is installed by a competent, qualified contractor, following all local and national codes, and industry standards.

What Bard Will Do About A Defect:

Bard will either repair or replace the defective part only. Replacement parts may be reconditioned parts. The warranty for the repaired or replaced part will last only for the remainder of the warranty period for the original part.

Defective parts must be supplied to a Bard distributor who will then submit a parts warranty claim form. Credits are issued to the Bard distributor.

Bard will not pay or be responsible for labor or defective/replacement part transportation costs or delays in repairing or failures to complete repairs caused by events beyond our reasonable control.

What You Must Do

1. Tell your heating and air conditioning contractor as soon as you discover a problem and have the contractor make repairs.
2. Pay for all transportation, related service labor, diagnostic charges, refrigerant, refrigerant recovery and related items.

Service

If your product requires service, you should contact the contractor who installed it or the contractor that has been providing the product's preventative maintenance and repair service. You may find the installing contractor's name on the product or in your Owner's packet. If you do not know who that is, you should contact a competent, qualified contractor to make the repairs. If in doubt, you should contact the nearest distributor that handles Bard products (www.bardhvac.com). Please note that contractors and distributors that handle Bard products are independent contractors and distributors, and therefore, are not under the direction of Bard Manufacturing Company, Inc.

Only Warranty

There are no other express warranties. All implied warranties are limited in duration to the duration of the applicable written warranty made above.

Some states do not allow limitations on how long an implied warranty lasts, so the above limitation or exclusion may not apply to you.

State of Florida Customers

The full length of the manufacturer's warranty of a HVAC system or component of the system is effective in the state of Florida on the date of installation if installed by a contractor licensed under part I of chapter 489. This form and the provided card are for warranty registration purposes. Failure to return the card or form does not diminish any warranty rights or decrease the warranty length.

BARD MANUFACTURING CO., INC. — BRYAN, OHIO 43506
Dependable quality equipment . . . since 1914

Form No. 7960-420
Issued: 08/13/24
Supersedes: 07/13/23

Duration Of Warranty is limited to defects arising during the periods shown in the following table:

Model Number Series:	— Number of Years from Installation Date ① —			
	Compressor ④	Sealed System Components ②④⑤	All Other Functional Parts ③	Heat Exchangers
AIR CONDITIONERS W12A, W18A, W24A, W30A, W36A, W42A, W48A, W60A, W72A, W090A, W120A, W150, W180A, W18L, W24L, W30L, W36L, W35A, W45A, W55A, Q36A, Q42A, Q48A, I30A, I36A, I42A, I48A, I60A, I36Z, I42Z, I48Z, I60Z	5	5	5	N/A
AIR SOURCE HEAT PUMPS W18H, W24H, W30H, W36H, W42H, W48H, W60H, C24H, C30H, C36H, C42H, C48H, C60H, T24H, T30H, T36H, T42H, T48H, T60H, T24S, T30S, T36S, T42S, T48S, T60S, Q24H, Q30H, Q36H, Q43H, Q48H, I30H, I36H, I42H, I48H, I60H, I36Z, I48Z, I60Z, W3VH, W5VH	5	5	5	N/A
ENVIRONMENTAL CONTROL UNITS W6RV, W6LV	5	5	1	N/A
AGRICULTURAL UNITS A36R and all HVAC equipment used in this application.	5	5	1	N/A
EQUIPMENT SHELTER UNITS MULTI-TEC, MEGA-TEC, FUSION-TEC, and all HVAC equipment used in this application.	5	5	1	N/A
GEOHERMAL/WATER SOURCE HEAT PUMPS QW2S, QW3S, QW4S, QW5S, QC50 (No Compressor)	5	5	5	N/A
GAS/ELECTRIC WALL-MOUNT W24G, W30G, W36G, W42G, W48G, W60G, WG2S, WG3S, WG4S, WG5S	5	5	5	10
ACCESSORIES Factory/Field Installed Bard Ventilation and Heater Packages, Bard branded Thermostats/ Temperature Controllers, UV-C LED Light Kits, LC6000, LV1000, MC4002, DC3003, TEC40, BG1000, PGD, PGDX, MC5300, MC5600.	N/A	N/A	5	N/A
Humidistats, C02 Controllers, add-on controller/thermostat cards and all other field-installed accessories not listed separately	N/A	N/A	1	N/A

- ① For equipment that does not have an online warranty registration, the warranty period starts when the product was shipped from the factory.
- ② Heat transfer coils (refrigerant to air coils for air source and coaxial coils for water source units) are covered for leaks for 5 years. Physical damage to air side coils resulting in leaks or insufficient airflow, or fin deterioration due to corrosive atmosphere (such as acids, halogenated hydrocarbons, agricultural or coastal environmental conditions) are not covered. Leaks in coaxial coils due to freezing of the coils are not covered. Copper coaxial coils for QW are not warranted for ground water/open loop installations.
- ③ Functional parts warranty is 1 year for all telecommunication, electric switch stations, pump stations, agricultural use, and similar applications. This also applies to all OTR (over the road) applications.
- ④ All OTR (over the road) applications that are moved from one location to another:
Factory Warranty applies up to the point of initial start-up and test at all OEM manufacturing locations or subsequent outfitting facility. Once it goes into OTR service, the warranty expires immediately for compressor and sealed system components. This OTR exemption does not apply to relocatable classrooms, construction, or office trailers.
- ⑤ Factory-coated coils have a "5" year warranty in corrosive environments that are listed as approved.



Internet Resources

Recognized as a leader in the HVAC industry, Bard combines quality products and outstanding service with innovation and technological advances to deliver high-performance heating and cooling products around the world. Please visit www.bardhvac.com for additional information regarding warranty and product information.



Literature Assembly
911-0912
Book 2 of 2

Contains the following:

2100-805

Wall Mount PKG H/P Manual

INSTALLATION INSTRUCTIONS

11EER CH Series Wall Mount Heat Pump

Models:

C36HF-A C42HF-A C48HF-A C60HF-A

C36HF-B C42HF-B C48HF-B C60HF-B

C36HF-C C42HF-C C48HF-C C60HF-C

C36HFDA C42HFDA C48HFDA C60HFDA

C36HFDB C42HFDB C48HFDB C60HFDB

C36HFDC C42HFDC C48HFDC C60HFDC



Bard Manufacturing Company, Inc.
Bryan, Ohio 43506
www.bardvac.com

Manual: 2100-805
Supersedes: **NEW**
Date: 11-12-24

CONTENTS

Safety Instructions	4	Phase Monitor.....	33
General Information	12	Condenser Fan Operation	33
Shipping Damage	12	Service Hints	33
Additional Publications	12	Sequence of Operation.....	33
Heat Pump Wall Mount Model Nomenclature	13	Cooling Stage 1.....	33
Ductwork.....	14	Cooling Stage 2.....	33
Filters	14	Heating Stage 1	34
Filter Removal/Installation.....	14	Heating Stage 2	34
Switching Filter Sizes	15	Heating Stage 2 & Electric Heat (Up to 10 kW)...	34
Fresh Air Intake	16	Emergency Heat.....	34
Installation	17	Low Ambient Conditions.....	34
Basic Installation Design and Application Planning	17	Defrost Cycle	34
Wall Construction	17	Low Pressure Switch Bypass Operation.....	36
Outdoor Area Inspection.....	17	High Pressure Switch Operation.....	36
Condensate Water Drainage	17	Vent Connection Plug.....	36
Indoor Ducted and Non-Ducted Applications.....	17	Pressure Service Ports	36
Indoor Supply Airflow.....	17	Service	37
Indoor Return Airflow.....	17	Solid State Heat Pump Control Troubleshooting	
Ducted Applications	18	Procedure	37
Free Blow Applications.....	18	Checking Temperature Sensor Outside Unit	
Thermostat or Indoor Temperature Sensor		Circuit.....	38
Placement	18	Troubleshooting ECM™ Indoor Blower Motors	39
Unit Installation	18	Replacing ECM Control Module.....	40
Materials/Tool List	19	Refrigerant Leak Detection System (RDS)	43
Wall Preparation.....	19	Why RDS?	43
Wall Mount Installation to Wall Surface	19	Sequence of Operation.....	43
Wiring – Main Power.....	26	Power Up and Self Test.....	44
High Voltage Connections.....	26	Normal Operation	44
Wiring – Low Voltage.....	27	Alarm State	44
Low Voltage Connections.....	27	Sensor Fault Mode	44
Unit Shutdown Feature	27	Mitigation Mode	44
Dehumidification Feature	27	Alarm Reset	44
Ventilation Features.....	27	RDS Diagnosis	44
Low Ambient Control	27	Sensor End-of-Life.....	44
Freeze Protection Thermostat	28	Fan Blade Setting Dimensions.....	47
Alarm Relay Feature	28	R-454B Refrigerant Charge	47
Dirty Filter Switch Indicator (DFS).....	28	Condenser Coil Cleaning Access.....	47
Refrigerant Leak Detection System (RDS)	28	Important Cleaning Note	47
Start Up	32	Unit Airflow	52
General	32	Dirty Filter Switch	52
Topping Off System Charge	32	Dirty Filter Switch Adjustment	53
Safety Practices	32		
Important Installer Note.....	32		
High Pressure Switch.....	32		
Three Phase Scroll Compressor Start Up			
Information.....	33		

FIGURES

Figure 1	Front Control Panel Cover	14
Figure 2	Removing Left Filter.....	14
Figure 3	Removing Second Filter.....	15
Figure 4	Filter Tabs in Up Position.....	15
Figure 5	Bend Filter Tabs Down.....	15
Figure 6	Remove Four Screws	15
Figure 7	Re-Install Filter Support Brackets into Lower Slots	15
Figure 8	Re-Install Screws and Bend Tabs Up.....	15
Figure 9	Install Right 2" Filter.....	16
Figure 10	Install Left 2" Filter.....	16
Figure 11	Fresh Air Damper.....	16
Figure 12	Vent Installation/Removal Clearance Required	20
Figure 13	Unit Dimensions	21
Figure 14	Mounting Instructions.....	22
Figure 15	Electric Heat Clearance	23
Figure 16	Wall Mounting Instructions	24
Figure 17	Wall Mounting Instructions	24
Figure 18	Common Wall Mounting Installations	25
Figure 19	High Voltage Connections	26
Figure 20	Programmable Thermostat Connections..	29
Figure 21	Programmable Thermostat Connections..	30
Figure 22	Non-Programmable Thermostat Connections	31
Figure 23	Defrost Control Board.....	35
Figure 24	Control Disassembly.....	41
Figure 25	Winding Test.....	41
Figure 26	Drip Loop.....	41
Figure 27	Control Connector Motor Half	42
Figure 28	Refrigerant Leak Detection System	43
Figure 29	Sensor Status LED Blink Code.....	44
Figure 30	Refrigerant Leak Detection System (RDS) Troubleshooting.....	45
Figure 31	Refrigerant Leak Detection System (RDS) Wiring Diagram	46
Figure 32	Fan Blade Setting	47
Figure 33	Condenser Coil Access Removal	47
Figure 34	Dirty Filter Switch and Dirty Filter Indicator Light/Reset Switch	52
Figure 35	Adjusting Filter Switch	53

TABLES

Table 1	Clearance Required for Service Access and Adequate Condenser Airflow.....	20
Table 2	Minimum Clearances Required to Combustible Materials.....	20
Table 3	Field Supplied Controls – Sequence of Operation.....	27
Table 4	Humidity Controls	28
Table 5	Wall Thermostats	28
Table 6	Thermostat Wire Size.....	28
Table 7	CO ₂ Controllers	28
Table 8	Troubleshooting	37
Table 9	Temperature vs. Resistance.....	38
Table 10	Troubleshooting ECM™ Indoor Blower Motors	42
Table 11	Fan Blade Dimensions.....	47
Table 12A	Cooling Pressures – Full Load.....	48
Table 12B	Cooling Pressures – Part Load	49
Table 13A	Heating Pressures – Full Load	50
Table 13B	Heating Pressures – Part Load.....	50
Table 14	Electrical Specifications C**HF	51
Table 15	Indoor Airflow Status and Unit Performance	54
Table 16	Electric Heat	54
Table 17	Vent and Control Options	55
Table 18	Optional Accessories	56

GRAPHS

Graph 1	CH FAD-NE5 Without Exhaust Ventilation Delivery	57
Graph 2	CH FAD-BE5 With Exhaust Ventilation Delivery	57
Graph 3	C36H & C42H CRV-FS Ventilation Delivery.....	58
Graph 4	C48H & C60H CRV-FS Ventilation Delivery.....	58

NOTICE

**APPLIANCE ACCESSIBLE TO THE GENERAL
PUBLIC.**

SAFETY INSTRUCTIONS

READ ALL INSTRUCTIONS BEFORE USE

Your safety and the safety of others are very important.

We have provided many important safety messages in this manual and on your appliance. Always read and follow all safety messages.

ANSI Z535.5 Definitions:

DANGER: Indicate[s] a hazardous situation which, if not avoided, will result in death or serious injury. The signal word “DANGER” is to be limited to the most extreme situations. DANGER [signs] should not be used for property damage hazards unless personal injury risk appropriate to these levels is also involved.

WARNING: Indicate[s] a hazardous situation which, if not avoided, could result in death or serious injury. WARNING [signs] should not be used for property damage hazards unless personal injury risk appropriate to this level is also involved.

CAUTION: Indicate[s] a hazardous situation which, if not avoided, could result in minor or moderate injury. CAUTION [signs] without a safety alert symbol may be used to alert against unsafe practices that can result in property damage only.

NOTICE: [this header is] preferred to address practices not related to personal injury. The safety alert symbol shall not be used with this signal word. As an alternative to “NOTICE” the word “CAUTION” without the safety alert symbol may be used to indicate a message not related to personal injury.

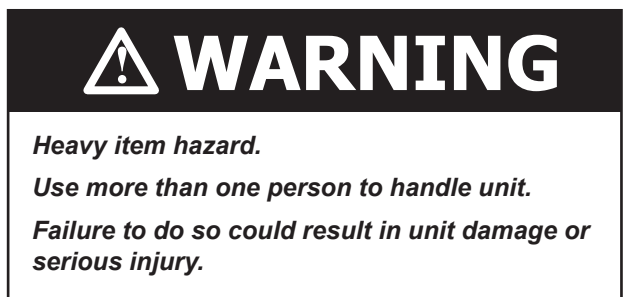
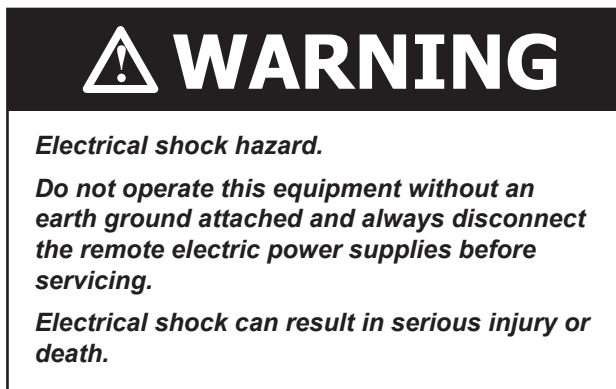
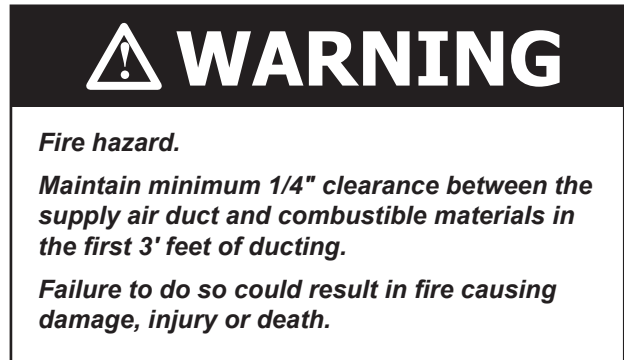

WARNING

Electrical shock hazard.

Have a properly trained individual perform these tasks.

Failure to do so could result in electric shock or death.

CAUTION

Sharp metallic edges.

Take care and wear appropriate protective devices to avoid accidental contact with sharp edges.

Failure to do so can result in personal injury.

WARNING

Do not use means to accelerate the defrosting process or to clean, other than those recommended by the manufacturer.

This appliance shall be stored in a room without continuously operating ignition sources (for example: open flames, an operating gas appliance or an operating electric heater.)

WARNING

Do not pierce or burn through copper.

Be aware that the refrigerant used in system may not contain an odor.

Ducts connected to appliance shall not contain a *POTENTIAL IGNITION SOURCE*.

The following symbols are displayed on units.



This symbol indicates that the unit contains a mildly flammable refrigerant.

Refrigerant
Safety Group
A2L

This symbol indicates that the refrigerant used is classified as an A2L, or mildly flammable refrigerant.



This symbol indicates that the Operation Manual should be read carefully.



This symbol indicates that a service personnel should be handling this equipment with reference to the Installation Manual.



This symbol indicates that information is available such as the Operation Manual or Installation Manual.

IMPORTANT SAFETY INSTRUCTIONS



WARNING

To reduce the risk of explosion, fire, death, electric shock, scalding or injury to persons when using this product, follow basic precautions, including the following:

GENERAL

- The equipment covered in this manual is to be installed by trained, experienced service and installation technicians.
- This appliance is not intended for use by persons (including children) with reduced physical, sensory or mental capabilities, or lack of experience and knowledge, unless they have been given supervision or instruction concerning use of the appliance by a person responsible for their safety.
- The refrigerant system is completely assembled and charged. All internal wiring is complete.
- The unit is designed for use with or without duct work. Flanges are provided for attaching the supply and return ducts.
- These instructions explain the recommended method to install the air-cooled self-contained unit and the electrical wiring connections to the unit.
- These instructions and any instructions packaged with any separate equipment required to make up the entire air conditioning system should be carefully read before beginning the installation. Note particularly “Starting Procedure” and any tags and/or labels attached to the equipment.
- While these instructions are intended as a general recommended guide, they do not supersede any national and/or local codes in any way. Authorities having jurisdiction should be consulted before the installation is made. See Additional Publications for information on codes and standards.
- Size of unit for a proposed installation should be based on heat loss calculation made according to methods of Air Conditioning Contractors of America (ACCA). The air duct should be installed in accordance with the Standards of the National Fire Protection Association for the Installation of Air Conditioning and Ventilating Systems of Other Than Residence Type, NFPA No. 90A, and Residence Type Warm Air Heating and Air Conditioning Systems, NFPA No. 90B. Where local regulations are at a variance with instructions, installer should adhere to local codes.

INSTALLATION

- For appliances intended for use at altitudes exceeding 2,000 meters (6,562 feet), the maximum altitude of use shall be stated.
- Before use, the appliance must be properly installed as described in this manual.
- Contact the authorized service technician for repair or maintenance of this unit.
- Contact the installer for installation of this unit.
- The air conditioner is not intended for use by young children or invalids without supervision.
- Young children should be supervised to ensure that they do not play with the air conditioner.
- Installation work must be performed in accordance with the National Electric Code by qualified and authorized personnel only.
- Connect to a properly rated, protected, and sized power circuit to avoid electrical overload.
- Adhere to all industry recommended safety procedures including the use of long-sleeved gloves and safety glasses.
- Use care when unpacking and installing. The edges of the product may be sharp.
- Keep packaging materials out of the reach of children. These materials can pose a suffocation risk to children.
- Auxiliary devices which may be a POTENTIAL IGNITION SOURCE shall not be installed in the duct work. Examples of such POTENTIAL IGNITION SOURCES are hot surfaces with a temperature exceeding 700°C and electric switching devices.

IMPORTANT SAFETY INSTRUCTIONS



WARNING

OPERATION

- This appliance is not intended for use by persons (including children) with reduced physical, sensory, or mental capabilities, or lack of experience and knowledge, unless they have been given supervision or instruction concerning use of the appliance by a person responsible for their safety.
- Use this appliance only for its intended purpose.
- Never attempt to operate this appliance if it is damaged, malfunctioning, partially disassembled, or has missing or broken parts.
- Do not tamper with controls.
- Keep all required ventilation openings clear of obstructions.
- Ducts connected to an appliance shall not contain a POTENTIAL IGNITION SOURCE.

INSTRUCTIONS DE SÉCURITÉ

LIRE TOUTES LES INSTRUCTIONS AVANT UTILISATION

Votre sécurité et celle des autres sont très importantes.

Nous avons fourni de nombreux messages de sécurité importants dans ce manuel et sur votre appareil. Lisez et suivez toujours tous les messages de sécurité.

Définitions ANSI Z535.5 :

DANGER : Indique une situation dangereuse qui, si elle n'est pas évitée, entraînera certainement la mort ou des blessures graves. Le mot « DANGER » doit être limité aux situations extrêmes. Les indications « DANGER » ne doivent pas être utilisées pour les risques de dégâts matériels, à moins qu'il n'existe un risque concomitant de blessures corporelles.

AVERTISSEMENT : Indique une situation dangereuse qui, si elle n'est pas évitée, peut entraîner la mort ou des blessures graves. Les indications « AVERTISSEMENT » ne doivent pas être utilisées pour les risques de dégâts matériels, à moins qu'il n'existe un risque concomitant de blessures corporelles.

ATTENTION : Indique une situation dangereuse qui, si elle n'est pas évitée, peut entraîner des blessures mineures à modérées. Les indications « ATTENTION », sans symbole d'avertissement, peuvent être utilisées pour alerter sur des pratiques dangereuses pouvant entraîner des dégâts matériels uniquement.

REMARQUE : cet avis concerne les pratiques n'entraînant aucune blessure corporelle. Le symbole d'avertissement ne doit pas être utilisé avec ce mot. Comme alternative à « AVIS », le mot « ATTENTION » sans symbole d'avertissement peut être utilisé pour indiquer un message non lié à des blessures corporelles.



AVERTISSEMENT

Risque de choc électrique.

Ne pas faire fonctionner cet équipement sans qu'il soit relié à la terre et toujours débrancher les alimentations électriques avant de procéder aux opérations d'entretien.

Une électrisation peut entraîner des blessures graves ou la mort.

REMARQUE

APPAREIL ACCESSIBLE AU GRAND PUBLIC.

AVERTISSEMENT

Risque d'incendie.

Conserver un dégagement minimal de 6,35 mm/1/4 po entre le conduit d'air soufflé et les matériaux combustibles sur les 900 premiers millimètres (3 pi) du conduit.

Le non-respect de cette consigne entraîne des risques de dégâts matériels, de blessures corporelles ou de décès.

AVERTISSEMENT

Risque lié aux objets lourds.

Plusieurs personnes sont nécessaires à la manipulation de l'unité.

Le non-respect de cette consigne peut entraîner des dégâts à l'unité ou des blessures graves.



AVERTISSEMENT

Risque de choc électrique.

Ces tâches doivent être réalisées par une personne parfaitement qualifiée et formée.

Le non-respect de cette consigne peut entraîner des chocs électriques ou la mort.



ATTENTION

Arêtes métalliques vives.

Faites attention et portez des dispositifs de protection appropriés pour éviter tout contact accidentel avec des arêtes vives.

Le non-respect de cette consigne peut entraîner des blessures corporelles.



AVERTISSEMENT

N'utilisez pas de moyens pour accélérer le processus de dégivrage ou pour nettoyer, autres que ceux recommandés par le fabricant.

Cet appareil doit être entreposé dans une pièce sans sources d'inflammation fonctionnant en continu (par exemple : flammes nues, un appareil à gaz en fonctionnement ou un appareil de chauffage électrique en fonctionnement).



AVERTISSEMENT

Ne percez pas ou ne brûlez pas à travers le cuivre.

Sachez que le réfrigérant utilisé dans le système peut ne pas contenir d'odeur.

Les conduits raccordés à l'appareillage ne doivent pas contenir de SOURCE D'INFLAMMATION POTENTIELLE.

Les symboles suivants sont affichés sur les unités.



Ce symbole indique que l'unité contient un réfrigérant légèrement inflammable.

Refrigerant
Safety Group
A2L

Ce symbole indique que le réfrigérant utilisé est classé comme réfrigérant A2L ou légèrement inflammable.



Ce symbole indique que le manuel d'utilisation doit être lu attentivement.



Ce symbole indique qu'un membre du personnel de service devrait manipuler cet équipement en se référant au manuel d'installation.



Ce symbole indique que des informations sont disponibles telles que le manuel d'utilisation ou le manuel d'installation.

INSTRUCTIONS DE SÉCURITÉ IMPORTANTES



AVERTISSEMENT

Pour réduire le risque d'explosion, d'incendie, de décès, de choc électrique, d'échaudure ou de blessures pour les personnes lors de l'utilisation de ce produit, suivez les précautions de base, notamment les suivantes :

GÉNÉRALITÉS

- L'équipement couvert dans ce manuel doit être installé par des techniciens de service et d'installation formés et expérimentés.
- Cet appareil n'est pas destiné à être utilisé par des personnes (y compris des enfants) ayant des capacités physiques, sensorielles ou mentales réduites, ou un manque d'expérience et de connaissances, à moins qu'elles n'aient reçu la supervision ou l'instruction concernant l'utilisation de l'appareil par une personne responsable de leur sécurité.
- Le système de réfrigérant est complètement assemblé et chargé. Tout le câblage interne est complet.
- L'unité est conçue pour être utilisée avec ou sans conduits. Des brides sont prévues pour fixer les conduits d'alimentation et de retour.
- Ces instructions expliquent la méthode recommandée pour installer l'unité autonome refroidie à l'air et les connexions de câblage électrique à l'unité.
- Ces instructions et toutes les instructions emballées avec tout équipement distinct requis pour constituer l'ensemble du système de climatisation doivent être lues attentivement avant de commencer l'installation. Notez en particulier « Procédure de démarrage » et les étiquettes et / ou étiquettes attachées à l'équipement.
- Bien que ces instructions soient conçues comme un guide général recommandé, elles ne remplacent en aucune façon les codes nationaux et/ou locaux. Les autorités compétentes devraient être consultées avant que l'installation ne soit effectuée. Voir d'autres publications pour obtenir des renseignements sur les codes et les normes.
- La taille de l'unité pour une installation proposée devrait être basée sur le calcul de la perte de chaleur effectué selon les méthodes de Air Conditioning Contractors of America (ACCA). Le conduit d'air devrait être installé conformément aux Normes de la National Fire Protection Association for the Installation of Air Conditioning and Ventilating Systems of Other Than Residence Type, NFPA No. 90A, et aux Systèmes de chauffage et de climatisation d'air chaud de type résidence, NFPA No. 90B. Lorsque les réglementations locales sont en contradiction avec les instructions, l'installateur doit respecter les codes locaux.

L'INSTALLATION

- Pour les appareils destinés à être utilisés à des altitudes supérieures à 2 000 mètres (6 562 pieds), l'altitude maximale d'utilisation doit être indiquée.
- Avant utilisation, l'apppliance doit être correctement installée comme décrit dans ce manuel.
- Communiquez avec le technicien d'entretien autorisé pour la réparation ou l'entretien de cette unité.
- Contactez le programme d'installation pour l'installation de cet appareil.
- Le climatiseur n'est pas destiné à être utilisé par de jeunes enfants ou des invalides sans surveillance.
- Les jeunes enfants devraient être surveillés pour s'assurer qu'ils ne jouent pas avec le climatiseur.
- Les travaux d'installation doivent être effectués conformément au Code national de l'électricité par du personnel qualifié et autorisé uniquement.
- Connectez-vous à un circuit d'alimentation correctement évalué, protégé et dimensionné pour éviter les surcharges électriques.
- Respectez toutes les procédures de sécurité recommandées par l'industrie, y compris l'utilisation de gants à manches longues et de lunettes de sécurité.
- Faites attention lors du déballage et de l'installation. Les bords du produit peuvent être tranchants.
- Gardez les matériaux d'emballage hors de la portée des enfants. Ces matériaux peuvent poser un risque d'étouffement pour les enfants.
- Les dispositifs auxiliaires qui peuvent être une SOURCE D'INFLAMMATION POTENTIELLE ne doivent pas être installés dans les conduits. Des exemples de telles SOURCES D'INFLAMMATION POTENTIELLES sont les surfaces chaudes dont la température dépasse 700 °C et les dispositifs de commutation électrique.

INSTRUCTIONS DE SÉCURITÉ IMPORTANTES



AVERTISSEMENT

OPÉRATION

- Cet appareil n'est pas destiné à être utilisé par des personnes (y compris des enfants) ayant des capacités physiques, sensorielles ou mentales réduites, ou un manque d'expérience et de connaissances, à moins qu'elles n'aient reçu une supervision ou une instruction concernant l'utilisation de l'appareil par une personne responsable de leur sécurité.
- Utilisez cet appareil uniquement aux fins prévues.
- N'essayez jamais de faire fonctionner cet appareil s'il est endommagé, défectueux, partiellement démonté ou s'il a des pièces manquantes ou cassées.
- Ne pas altérer les contrôles.
- Gardez toutes les ouvertures de ventilation nécessaires à l'écart des obstacles.
- Les conduits raccordés à un appareil ne doivent pas contenir de SOURCE D'INFLAMMATION POTENTIELLE.

GENERAL INFORMATION

General

The equipment covered in this manual is to be installed by trained, experienced service and installation technicians.

The refrigerant system is completely assembled and charged. All internal wiring is complete.

The unit is designed for use with or without ductwork. Flanges are provided for attaching the supply and return ducts.

These instructions explain the recommended method to install the air cooled self-contained unit and the electrical wiring connections to the unit.

These instructions and any instructions packaged with any separate equipment required to make up the entire air conditioning system should be carefully read before beginning the installation. Note particularly "Starting Procedure" and any tags and/or labels attached to the equipment.

While these instructions are intended as a general recommended guide, they do not supersede any national and/or local codes in any way. Authorities having jurisdiction should be consulted before the installation is made. See **Additional Publications** for information on codes and standards.

Size of unit for a proposed installation should be based on heat loss/gain calculation made according to methods of Air Conditioning Contractors of America (ACCA). The air duct should be installed in accordance with the Standards of the National Fire Protection Association for the Installation of Air Conditioning and Ventilating Systems of Other Than Residence Type, NFPA No. 90A, and Residence Type Warm Air Heating and Air Conditioning Systems, NFPA No. 90B. Where local regulations are at a variance with instructions, installer should adhere to local codes.

Shipping Damage

Upon receipt of equipment, the carton should be checked for external signs of shipping damage. If damage is found, the receiving party must contact the last carrier immediately, preferably in writing, requesting inspection by the carrier's agent.

Additional Publications

These publications can help when installing the heat pump. They can usually be found at the local library or purchased directly from the publisher. Be sure to consult the current edition of each standard.

National Electrical CodeANSI/NFPA 70

Standard for the Installation of Air Conditioning and Ventilating Systems
.....ANSI/NFPA 90A

Standard for Warm Air Heating and Air Conditioning Systems
.....ANSI/NFPA 90B

Load Calculation for Winter and Summer Air Conditioning
..... ACCA Manual J Residential

Duct Design for Residential Winter and Summer Air Conditioning and Equipment Selection
..... ACCA Manual D

For more information, contact these publishers:

ACCA **Air Conditioning Contractors of America**
1712 New Hampshire Ave. N.W.
Washington, DC 20009
Telephone: (202) 483-9370
Fax: (202) 234-4721

ANSI **American National Standards Institute**
11 West Street, 13th Floor
New York, NY 10036
Telephone: (212) 642-4900
Fax: (212) 302-1286

ASHRAE **American Society of Heating, Refrigeration and Air Conditioning Engineers, Inc.**
1791 Tullie Circle, N.E.
Atlanta, GA 30329-2305
Telephone: (404) 636-8400
Fax: (404) 321-5478

NFPA **National Fire Protection Association**
Batterymarch Park
P.O. Box 9101
Quincy, MA 02269-9901
Telephone: (800) 344-3555
Fax: (617) 984-7057

Wall Mount Heat Pump Model Nomenclature

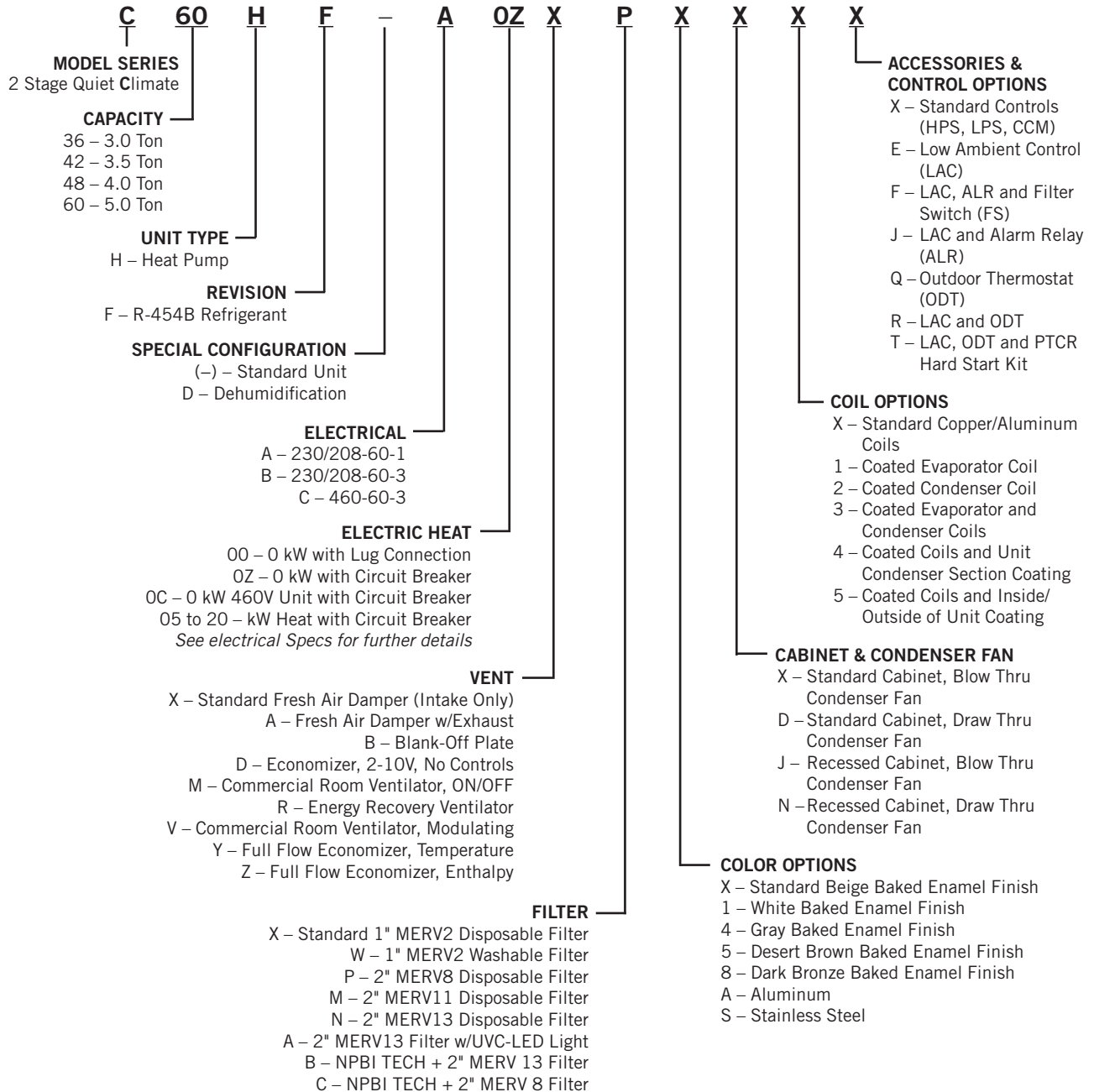

NOMENCLATURE NOTES:

- C36, C42, C48 and C60 models have the unit control panel located in the front of the unit.
- Accessories and control options may not be available for all models. See Specifications Sheet S3660 for further details.
- All units have an external data tag with the model and serial number on the left side of the unit. A secondary data tag with the model and serial number is located inside the control panel area on or near the low voltage terminal box.
- Aluminum and stainless steel cabinet finish not available in units with recessed cabinet top.
- Only "X" Cabinet and Condenser Fan option (Standard Cabinet, Blow Thru Condenser Fan) is available with dehum units.

Ductwork

All ductwork, supply and return, must be properly sized for the design airflow requirement of the equipment. Air Conditioning Contractors of America (ACCA) is an excellent guide to proper sizing. All ductwork or portions thereof not in the conditioned space should be properly insulated in order to both conserve energy and prevent condensation or moisture damage.

Design the ductwork according to methods given by the Air Conditioning Contractors of America (ACCA). When duct runs through unheated spaces, it should be insulated with a minimum of 1" of insulation. Use insulation with a vapor barrier on the outside of the insulation. Flexible joints should be used to connect the ductwork to the equipment in order to keep the noise transmission to a minimum.

All model series require a 1/4" clearance to combustible material for the first 3' of duct attached to the outlet air frame. See wall mounting instructions on page 19 and Figures 14 – 18 (pages 22 – 25) for further details.

Ducts through the walls must be insulated and all joints taped or sealed to prevent air or moisture entering the wall cavity.

Some installations may not require a return air duct. A metallic return air grille is required with installations not requiring a return air duct. The spacing between louvers on the grille shall not be larger than 5/8".

Any grille that meets with 5/8" louver criteria may be used. It is recommended that Bard Return Air Grille Kits RG5 or RFG5 be installed when no return duct is used. Contact distributor or factory for ordering information. If using a return air filter grille, filters must be of sufficient size to allow a maximum velocity of 400 fpm.

NOTE: *If no return air duct is used, applicable installation codes may limit this cabinet to installation only in a single story structure.*

Filters

The filters can be serviced from the outside by removing the front control panel cover (see Figure 1). Two (2) 20" x 20" x 1" throwaway filters come standard with each unit. Additional 1" and 2" filter options are available as optional accessories. To be notified when filters need changed, a dirty filter switch option is available. See page 55 for the dirty filter switch kit.

FIGURE 1
Front Control Panel Cover

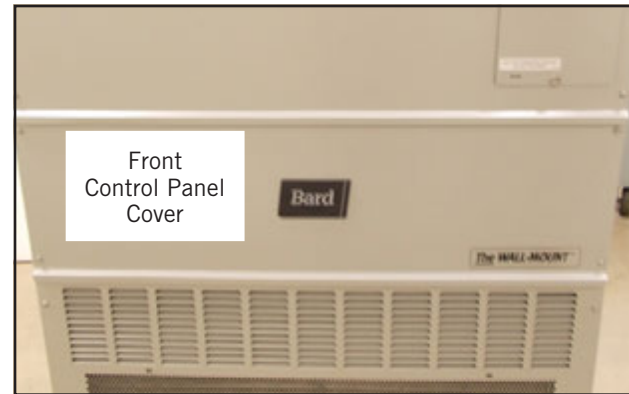

Filter Removal/Installation

1. Remove left filter first by pulling filter removal slide out (see Figure 2).

FIGURE 2
Removing Left Filter

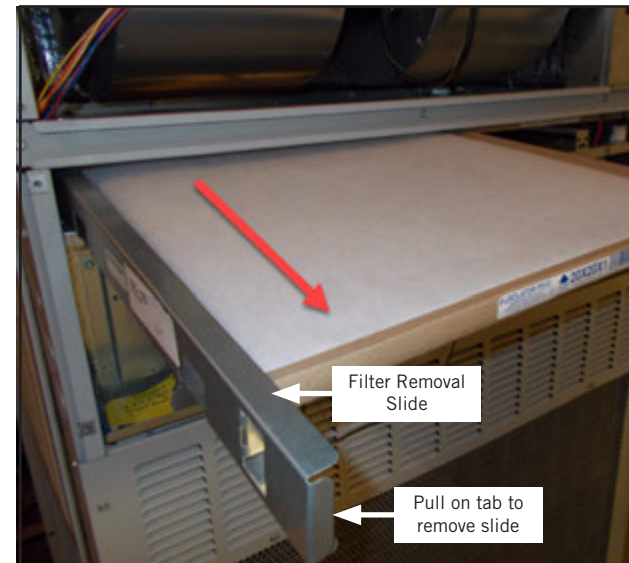

2. Slide second filter to the left around the wires and pull the filter out (see Figure 3).

FIGURE 3
Removing Second Filter

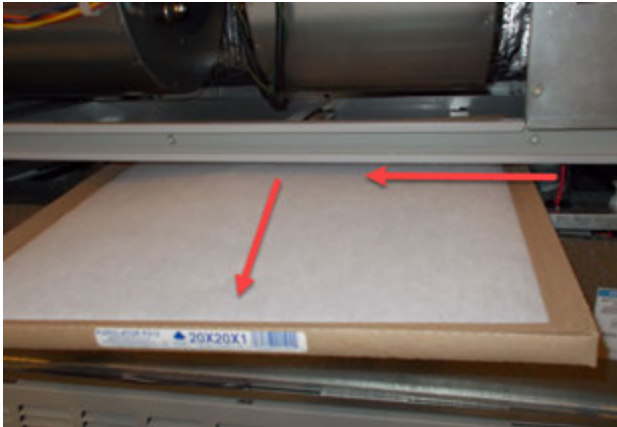

3. Reverse the order for new filter installation.

NOTE: When installing new filters, make sure that airflow arrows on filters point up.

Switching Filter Sizes

1. To switch from 1" to 2" filters, start by removing the filter slide and bend the tabs down out of the way (see Figures 4 and 5).

FIGURE 4
Filter Tabs in Up Position (1" Filter)



FIGURE 5
Bend Filter Tabs Down (2" Filter)



2. Locate the filter support brackets and remove the four (4) screws holding them to the top of the control panel (see Figure 6).

FIGURE 6
Remove Four Screws



3. Pull the brackets out towards the front of the unit. The back of the bracket will slip out of the upper slots at the back of the filter tray.

4. Re-install the filter support brackets into the lower slots at the back of the filter tray (see Figure 7).

FIGURE 7
Re-Install Filter Support Brackets into Lower Slots

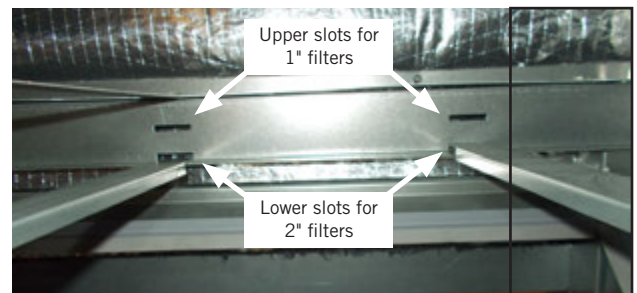

5. Re-install the four (4) hex head screws into the upper screw holes on the filter support brackets. Then bend the tab up out of the way (see Figure 8).

FIGURE 8
Re-Install Screws and Bend Tabs Up



6. Install the right 2" filter first followed by the left filter (see Figures 9 and 10).

NOTE: When installing new filters, make sure that airflow arrows on filters point up.

7. Reverse the steps above to switch from 2" to 1" filters.

FIGURE 9
Install Right 2" Filter



FIGURE 10
Install Left 2" Filter



Fresh Air Intake

All units are built with fresh air inlet louvers punched in the side grilles.

If the unit is equipped with a fresh air damper assembly, the assembly is shipped already attached to the unit. Remove right side grille to access the damper blade.

There is an adjustable slide on the side of the fresh air intake that can be adjusted to limit how far the damper opens so that the amount of fresh air that enters the structure is regulated. The damper is shipped pre-set in the #1 position.

Graphs found on pages 57 and 58 give approximate fresh air amounts based on the slide adjustment setting.

All capacity, efficiency and cost of operation information is based upon the fresh air blank-off plate in place.

The fresh air damper is a standard option shipped with each unit. However, the blank-off plate option can be selected and installed in place of the fresh air damper. For ordering information regarding the blank-off plate or any other field-installed option, please contact the local distributor.

FIGURE 11
Fresh Air Damper

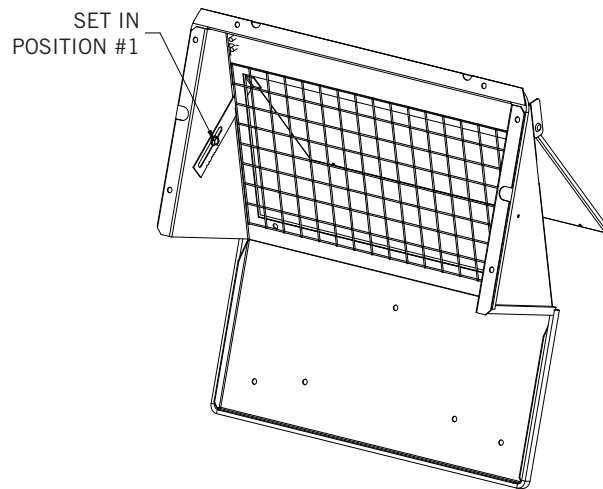

MIS-3977A

Basic Installation Design and Application Planning

Successful unit installations require proper planning and site inspection before installation begins. Before installing the wall mount unit, make sure that all service and airflow clearances are met and that the unit can meet all applicable code and regulation requirements. Provide an inspection of both the inside and outside of the structure by reviewing floor plans and/or visiting the installation site.

Wall Construction

The wall must be inspected to ensure that the weight of the unit can be supported. Be sure to review all applicable construction codes and regulations including seismic requirements. When inspecting wood frame walls, the wall construction must be strong and rigid enough to carry the weight of the unit without transmitting any unit vibration. It is important that the side unit wall mounting lags and optional bottom bracket are supported by structural members inside the wall cavity. Concrete block and brick walls must be thoroughly inspected to ensure that they are capable of carrying the weight of the installed unit. Metal buildings must contain structural components to support the unit weight. If heavily corrugated siding is present, it may need to be trimmed and flashed similar to a window to provide a flat, even surface to attach and seal the unit to the wall. Heavy gauge corrugations that would be present on shipping containers and blast-proof structures may require the installation of a metal plate over the corrugated area. It is important that the unit area is weatherized and sealed to avoid air and water infiltration into the area between the unit and the wall.

Outdoor Area Inspection

Inspect the outdoor area of the jobsite or review construction plans and locate the area where the wall mount is to be installed. The outdoor area must be free from obstructions including fences, bushes and walls that will hinder unit operation regarding outdoor condenser airflow and unit serviceability. Do not install units in enclosed areas that limit the amount of ambient temperature airflow.

If the unit is a "blow thru" configuration, warm air will exit the front condenser section of the unit, and outdoor ambient temperature air must be able to enter side intake condenser openings of the unit.

On a unit configured with air being drawn through the condenser (draw thru configuration), warm air will exit from both sides of the condenser section of the unit and outdoor ambient temperature air must be able to enter from the front through the condenser grill of the unit.

Portable or modular building placement must be in a way that the wall mount units have a constant supply of outdoor air for proper unit operation. Make sure that the service panels of the unit are accessible. Inspect wall surfaces for obstructions that could hinder unit installation and servicing including outdoor electrical conduits, junction boxes, wall drains, vent hoods, windows, doors, overhangs and posts.

Condensate Water Drainage

Review all codes and requirements for unit condensate drainage. A clear, flexible PVC drain hose (3/4" ID, 1" OD) extends from the drain pan in the upper section of the unit and extends down to the unit base. An opening is supplied towards the back of the unit base for the drain hose to pass through, and the hose extends 1" to 2" below the unit base. Water removed from the indoor air (condensate) will be expelled from the unit in large amounts during cooling operation through the hose. Units running in cooling operation in cold outdoor below freezing conditions can cause the condensate to freeze after leaving the drain hose. In the event the drain hose is connected to a drain system of some type, it must be an open or vented type system to ensure proper drainage throughout seasonal use.

Indoor Ducted and Non-Ducted Applications

Air distribution inside the structure being conditioned plays an important role in making sure the area is a consistent temperature. Improper air distribution can result in areas being cooler or warmer, electrical equipment not receiving sufficient airflow or occupancy discomfort felt inside an area. Thermostat or indoor temperature sensor placement inside the area being conditioned also plays an important role in indoor climate control.

Indoor Supply Airflow

Indoor installation areas must provide a non-restrictive path for the conditioned supply air to leave supply grilles and registers. Inspect the area to ensure that all indoor portions of the room or rooms will have access to supply air. Ductwork may be used to ensure proper air circulation and all provided ductwork guidelines and clearances must be followed. Non-ducted applications must use a supply louver grille installed over the supply opening inside the room. Be sure to adjust supply deflectors to properly disperse the conditioned supply air to all parts of the room. Avoid closing sections of the supply grilles which would cause unneeded supply duct pressurization.

Indoor Return Airflow

A non-restrictive path for room air returning to the center section of the unit must be provided inside

the room. Avoid placing objects including furniture, electronics equipment, equipment racks and cabinets directly in front of the unit return grilles and registers. Bard recommends at least 2' between solid objects and return grilles or registers. Ductwork may be used to ensure proper air circulation and all provided ductwork guidelines and clearances must be followed. Non-ducted applications must use a return louver grille installed over the return opening inside the room.

Ducted Applications

Field fabricated supply and return ductwork may be installed inside the structure being conditioned. A short supply and/or return stub duct may be connected to the unit supply and return flanges before unit installation to help with duct connections inside the structure. Supply and return ducts must be properly sized for the design airflow requirement of the equipment. Air Conditioning Contractors of America (ACCA) is an excellent guide to proper sizing. All ductwork or portions thereof not in the conditioned space should be properly insulated in order to conserve energy, reduce heat conductivity, and prevent condensation or moisture damage. Design the ductwork according to methods given by the Air Conditioning Contractors of America (ACCA). When ductwork is installed in unheated spaces, it should be insulated with a minimum of 1" of insulation. Use insulation with a vapor barrier on the outside of the insulation. Flexible joints should be used to connect the ductwork to the equipment in order to keep the noise transmission to a minimum. Ducts through the walls must be insulated and all joints taped or sealed to prevent air or moisture from entering the wall cavity.

All model series require a 1/4" clearance to combustible material for the first 3' of duct attached to the outlet air frame is required. See instructions on page 19 and Figures 14 – 18 (pages 22 – 25) for further details.

WARNING

Fire hazard.

Maintain minimum 1/4" clearance between the supply air duct and combustible materials in the first 3' of ducting.

Failure to do so could result in fire causing damage, injury or death.

Free Blow Applications

Some installations may not require extensive supply ductwork throughout the structure and are referred to as free blow applications. A short field-fabricated supply duct must be used in the wall cavity to transition between the supply collar on the unit and

the supply louver grille in the room. The duct must be properly insulated in order to conserve energy, reduce heat conductivity and prevent condensation or moisture damage. All joints must be taped or sealed to prevent air or moisture entering the wall cavity. Follow all clearances including distances to combustible materials and all instructions provided in this manual. A non-restrictive metallic supply air grille with deflectors is required for free blow applications. Contact the local Bard distributor or visit www.bardhvac.com for ordering information.

A metallic return air grille is required for non-ducted applications. The spacing between louvers on the grille shall not be larger than 5/8". It is recommended that a Bard Return Air Grille Kit is installed that is designed specifically for the wall mount product. Contact the local Bard distributor or visit www.bardhvac.com for ordering information. A field-supplied return grille that meets the 5/8" louver criteria and does not cause the unit to exceed the maximum specified external static pressure (ESP) may be used. If using a return air filter grille, filters must be of sufficient size to allow a maximum velocity of 400 fpm. Filter return air grilles do not filter air being brought into the structure through ventilation options including fresh air dampers, ventilators, economizers and energy recovery ventilators. Be sure to install the return grille with the louvers pointed downward towards the floor. This will help ensure return air is drawn upward from the floor and improve air circulation in the room.

NOTE: *If no return air duct is used, applicable installation codes may limit this cabinet to installation only in a single story structure.*

Thermostat or Indoor Temperature Sensor Placement

The location and installation of the thermostat or temperature sensor that monitors indoor temperature is very important regarding unit operation. Avoid placing the thermostat in an area exposed to direct sunlight or air from doorways leading outdoors. Use a piece of insulating material to close off conduit openings or holes in the wall surface for wire entry into the thermostat or temperature sensor. This will help avoid non-conditioned air from entering the thermostat and effecting temperature and/or humidity readings. As common practice, the thermostat or temperature sensor should measure the temperature of the air being returned to the unit, and not the conditioned air being supplied by the unit. Placing the thermostat or temperature sensor near a return air opening will normally result in optimal unit performance.

Unit Installation

Make sure to have the proper tools at the work site that are needed for unit installation. The following steps are provided to ensure the unit is installed properly to the wall surface, and that the unit will provide years of service with minimal service requirements.

Materials/Tools List

Additional hardware and miscellaneous supplies are needed for installation. These items are field supplied and must be sourced before installation. This list also includes tools needed for installation.

- Appropriate safety gear including gloves and safety glasses
- 5/16" hex bit with drill driver
- Phillips head screwdriver
- Small straight (thermostat) screwdriver
- Tape measure
- Leveling device
- Two (2) tubes of caulk and caulk gun
- Utility knife
- Tools for cutting holes in the wall surface (if needed)
- Electrical components and wiring along with electrical tools
- Multimeter
- Wall fasteners for side flanges, bottom mounting bracket and top rain flashing.
- Duct tape and/or other duct sealing materials.

Wall Preparation

1. Two holes for the supply and return air openings must be cut through the wall as shown in Figure 14 on page 22. Be sure the openings are square and level. Follow all clearances including distances to combustible materials and all instructions provided in this manual.
2. Review all electrical requirements provided in this manual and plan out electrical entrances into the building. Also plan electrical conduit routing and thermostat placement, if necessary.
3. Install necessary ductwork and prepare the openings for unit installation.
4. Clean the exterior wall where the unit is to be installed and make sure it is able to provide a smooth, level, debris-free surface. Remove all construction debris from the supply, return and electrical hole cutting process.

Wall Mount Installation to Wall Surface

1. Remove packaging from unit and make sure the unit is not damaged before installation. A top rain flashing is supplied for field use and is mounted to the back of the unit for shipping. Remove the rain flashing before locating the unit against the wall. Top rain flashing is required to avoid water entering the area behind the unit that is against the wall. A bottom mounting bracket, attached to the skid for shipping, is provided for ease of installation but

is not required. Review all requirements listed on unit labels and on serial plate located on the side of the unit.

2. Locate and mark bolt hole locations and bottom mounting bracket location. Install bottom mounting bracket with field-supplied fasteners to wall if it is to be used (optional). Bracket must be level and installed in the correct location to help support the unit during the installation process (see Figure 14).
3. Position the wall mount unit close to the wall surface where it will be installed. Install rain flashing at the top of the unit facing the wall by hooking the hem bend into the rear bend of the unit top (see Figure 14).
4. Apply a liberal amount of caulk on left and right cabinet side wall mount brackets and back of top rain flashing. Place unit back surface flush against wall. Unit must be level to ensure proper condensate drainage. Optional bottom bracket may be used to help support the unit.
5. Units are secured to the wall by using field-supplied fasteners along each side of the wall mount through the built-in wall mounting brackets. It is the responsibility of the installer to select the proper fastener to secure the unit to the wall based on wall construction and applicable building codes. Typical installations may include 5/16" fasteners with 7/8" diameter flat washers. Be sure unit is securely mounted and all weight-bearing fasteners are attached to the weight supporting structural members of the wall.
6. Apply a bead of caulk between the back of the unit top and the front surface of the top rain flashing (see Figure 14).
7. Connect unit ductwork from the inside of the building following all clearances and instructions provided. For additional mounting rigidity, the return air and supply air frames or collars can be drilled and screwed or welded to the structural wall itself (depending upon wall construction). Be sure to use code approved duct tape or other sealing materials to seal the ductwork to the unit.
8. On side-by-side installations, maintain a minimum of 20" clearance on both sides to allow access to heat strips and to provide proper airflow to the outdoor coil. Additional clearance may be required to meet local or national codes.

TABLE 1
Clearance Required for Service Access and Adequate Condenser Airflow

Model	Left Side*	Right Side*	Discharge – Front
C36HF C42HF C48HF C60HF	20"	20"	10'

TABLE 2
Minimum Clearances Required to Combustible Materials

Model	Supply Air Duct (1st 3')	Cabinet
C36HF C42HF C48HF C60HF	1/4"	0"

* For vent installation and removal, one side of the unit requires 45" clearance in the vent area. See Figure 12 for clarity.

See Specifications Sheet S3630.

FIGURE 12
Vent Installation/Removal Clearance Required

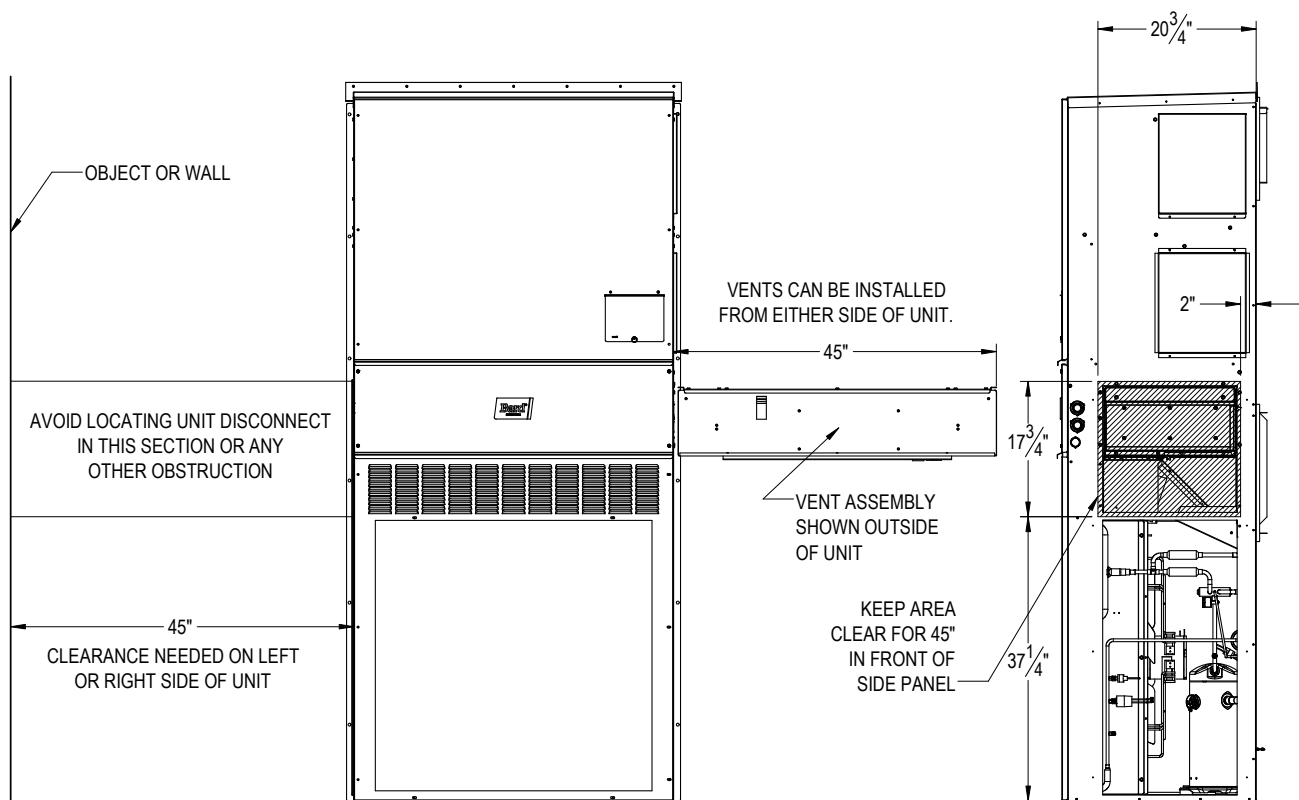

MIS-4042 A

FIGURE 13
Unit Dimensions

	Width (W)	Depth (D)	Height (H)	Supply		Return															U	V
				A	B	C	B	E	F	G	I	J	K	L	M	N	O	R	S	T		
C36HF C42HF	42.00	25.52	84.75	9.88	29.88	15.88	29.88	43.88	12.63	39.06	30.06	43.25	26.94	55.59	52.59	8.82	43.00	1.44	16.00	1.88	10.50	12.00
C48HF C60HF	42.00	25.52	92.88	9.88	29.88	15.88	29.88	43.88	12.63	45.00	30.06	49.25	35.06	61.72	58.72	8.82	43.00	1.44	16.00	10.00	13.88	15.43

All dimensions are in inches. Dimensional drawings are not to scale.

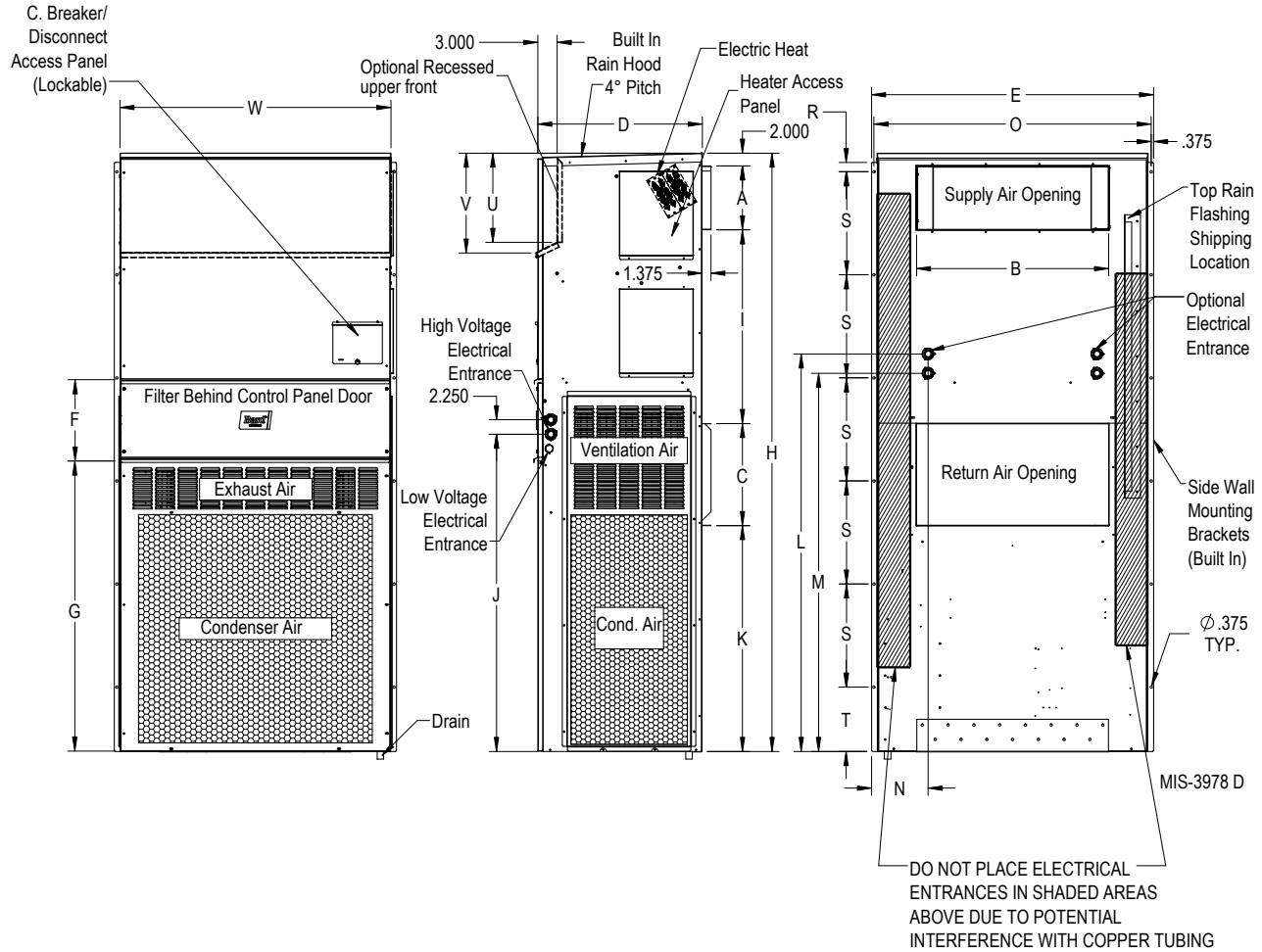
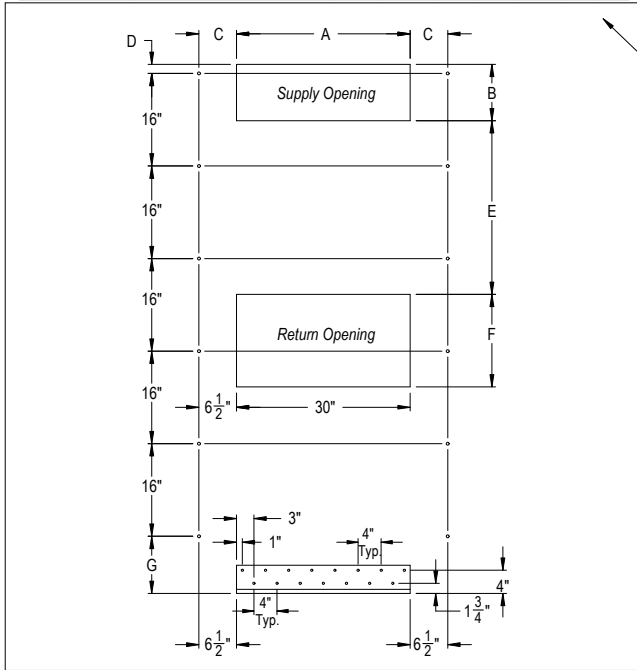
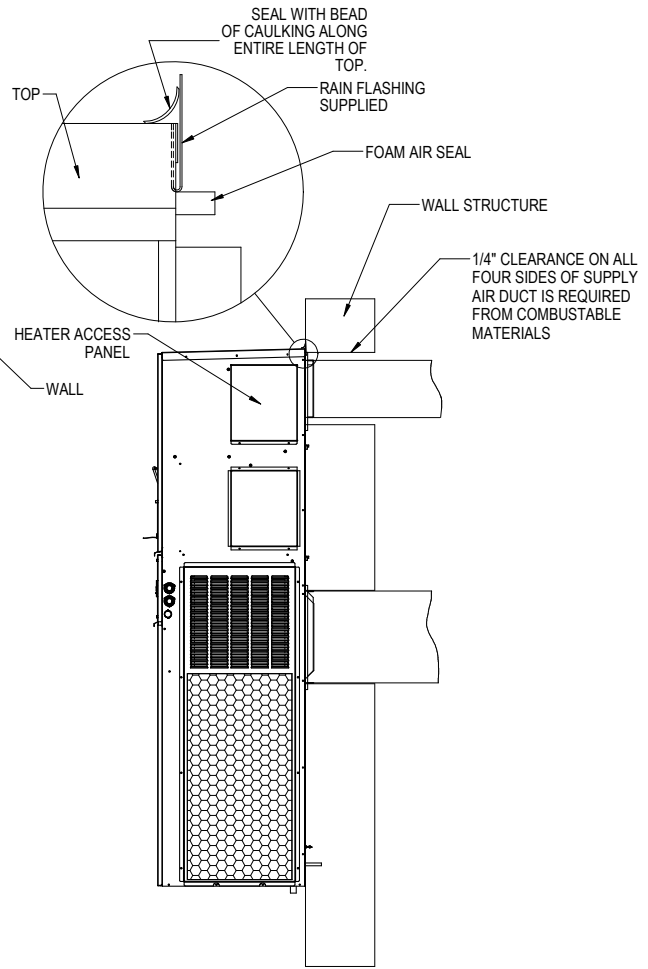

FIGURE 14
Mounting Instructions

UNITS	REQUIRED DIMENSIONS	A	B	C	D	E	F	G
C36HF-42HF UNITS	REQUIRED DIMENSIONS TO MAINTAIN 1/4" MIN. CLEARANCE FROM COMBUSTIBLE MATERIALS	30 1/2	10 1/2	6 1/4	1 1/4	29 3/4	16	1 7/8
	REQUIRED DIMENSIONS TO MAINTAIN RECOMMENDED 1" CLEARANCE FROM COMBUSTIBLE MATERIALS	32	12	5 1/2	2	29	16	1 7/8
C48HF-60HF UNITS	REQUIRED DIMENSIONS TO MAINTAIN 1/4" MIN. CLEARANCE FROM COMBUSTIBLE MATERIALS	30 1/2	10 1/2	6 1/4	1 1/4	29 3/4	16	10
	REQUIRED DIMENSIONS TO MAINTAIN RECOMMENDED 1" CLEARANCE FROM COMBUSTIBLE MATERIALS	32	12	5 1/2	2	29	16	10



Wall Opening and Hole Location View



Right Side View

MIS-4425

FIGURE 15
Electric Heat Clearance

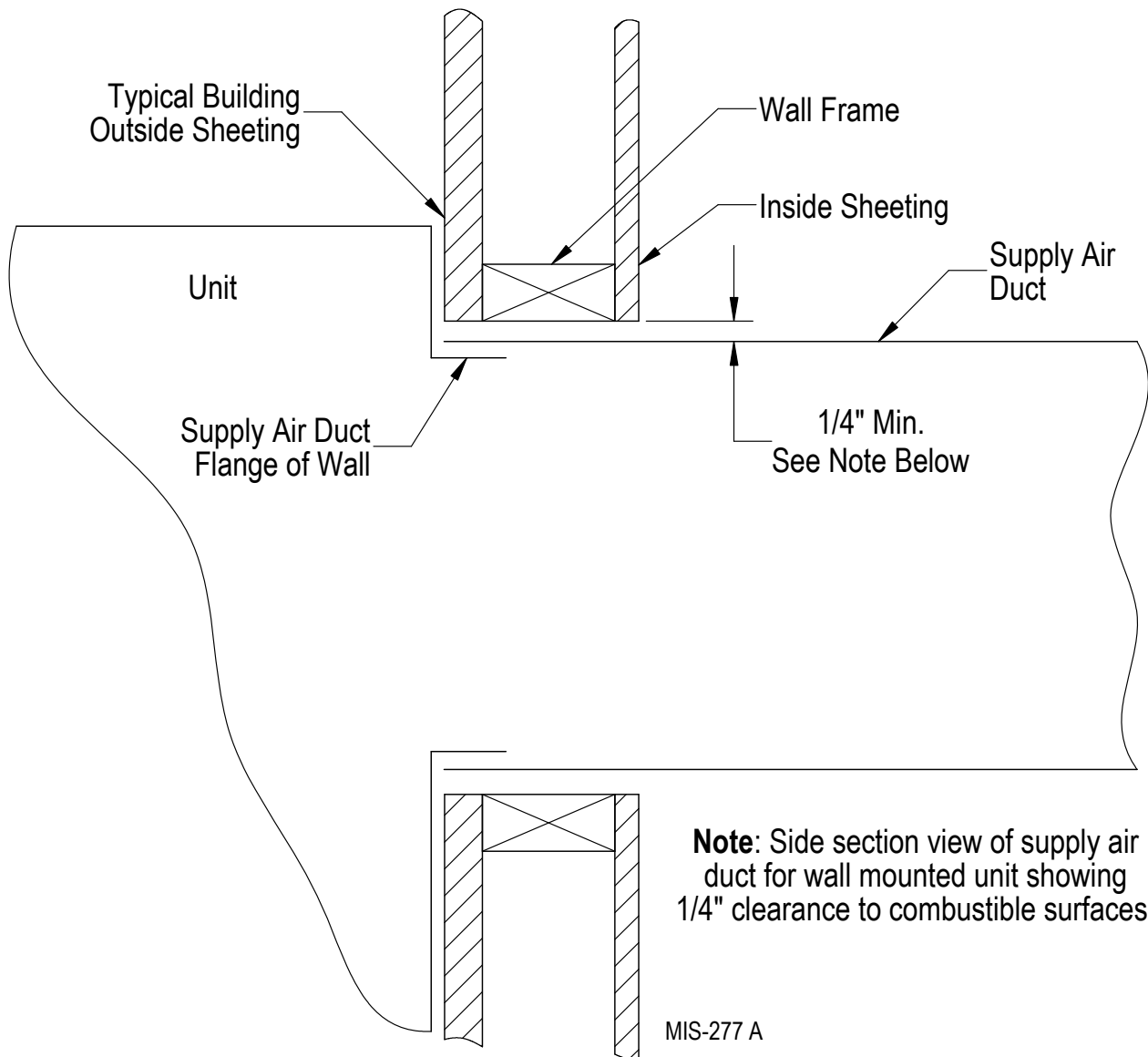

⚠ WARNING

Fire hazard.

Maintain minimum 1/4" clearance between the supply air duct and combustible materials in the first 3' of ducting.

Failure to do so could result in fire causing damage, injury or death.

FIGURE 16
Wall Mounting Instructions

See Figure 14 Mounting Instructions

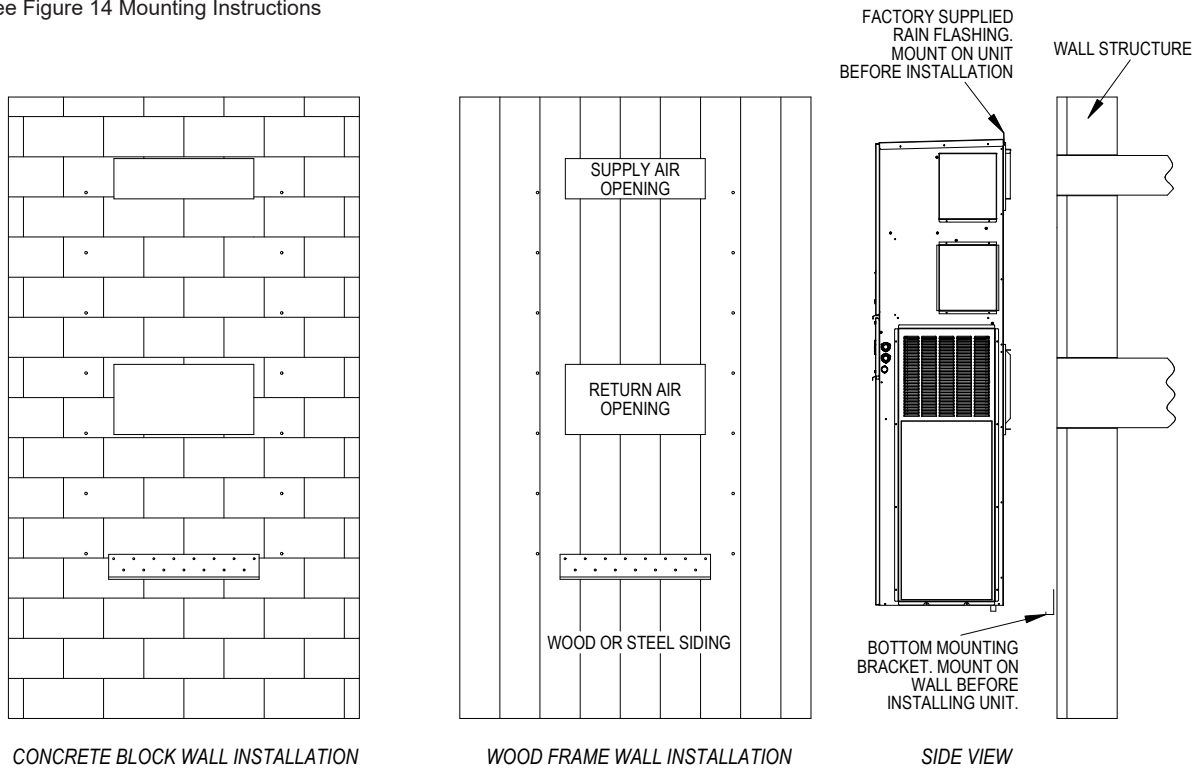

MIS-3981 C

FIGURE 17
Wall Mounting Instructions

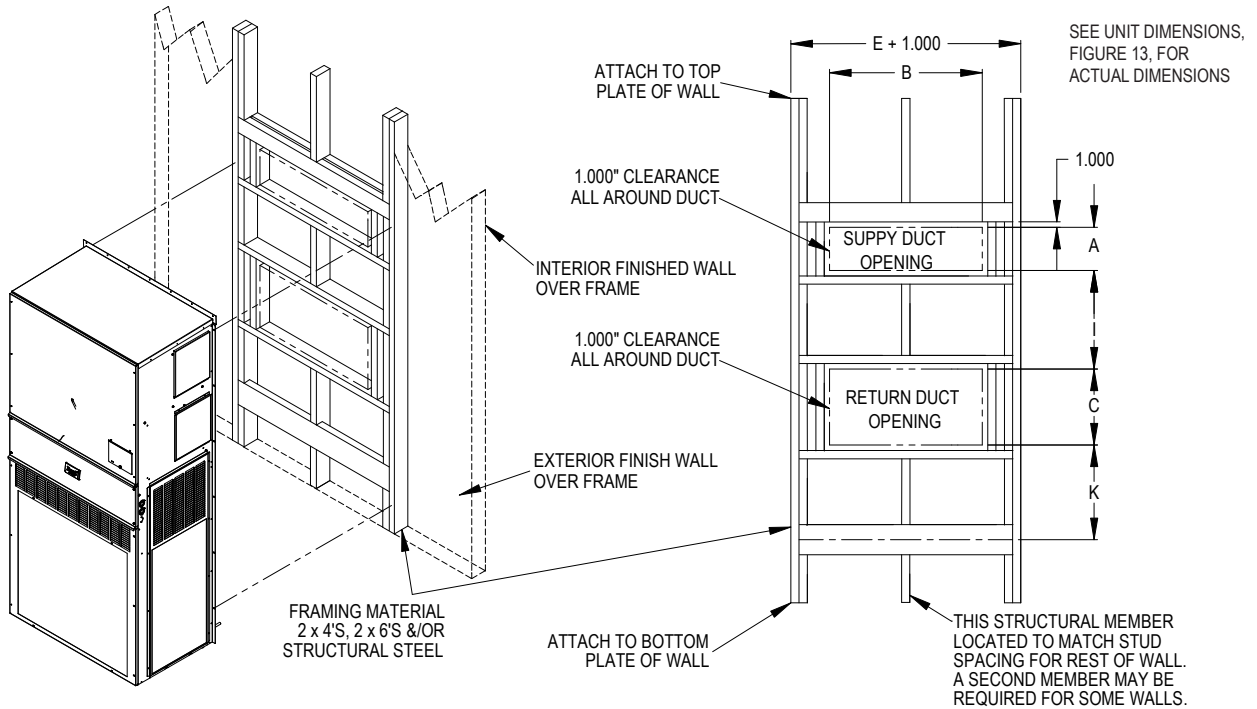

MIS-3982 B

FIGURE 18
Common Wall Mounting Installations

Non-Ducted Installations

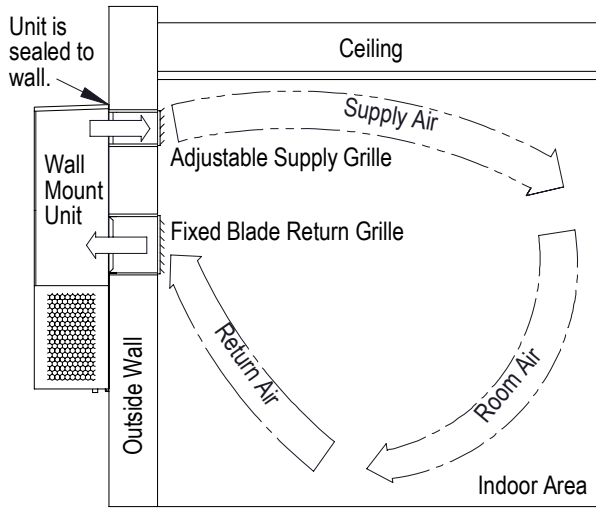

Non-ducted installations supply conditioned air into indoor room areas without extensive duct work. The supply airstream is directed by adjusting the 4-way supply grille to reach areas being conditioned. The supply air mixes with the room air and cools or heats occupants and/or equipment in the area. Unconditioned room air is returned to the unit through the return grille. Avoid supply air leaving supply grille and re-entering the unit return grille without mixing with room air.

Ducted Installations

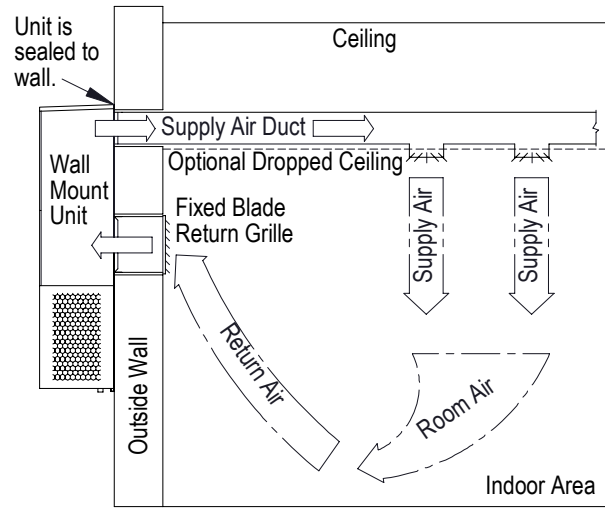

Ducted installations supply conditioned air into indoor room areas using solid or flexible ducts. The supply air is distributed throughout a single area or multiple areas. The supply air mixes with the room air and cools or heats occupants and/or equipment. Unconditioned room air is returned to the unit through a return grille or return duct work. Avoid using restrictive duct work to provide the best unit performance and efficiency. Review duct static pressure requirements provided in this manual.

Outdoor Wall Curb Installations

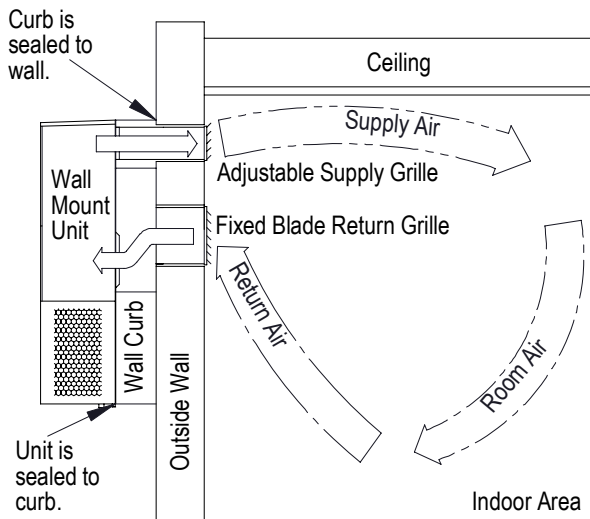

Outdoor Wall curbs are installed between the wall mount unit and the outer wall surface. Wall curb use may avoid resizing supply and return openings that are currently in an existing wall. Wall curbs may also provide sound isolation and indoor area sound reduction. Various curb options are available, and it is important to select a curb that will meet the application requirements and also be the correct size for the unit. Unit duct static requirements cannot be exceeded when using a wall curb. Follow all instructions provided with the wall curb when installing the product.

WAPR11 Indoor Sound Plenum Installations

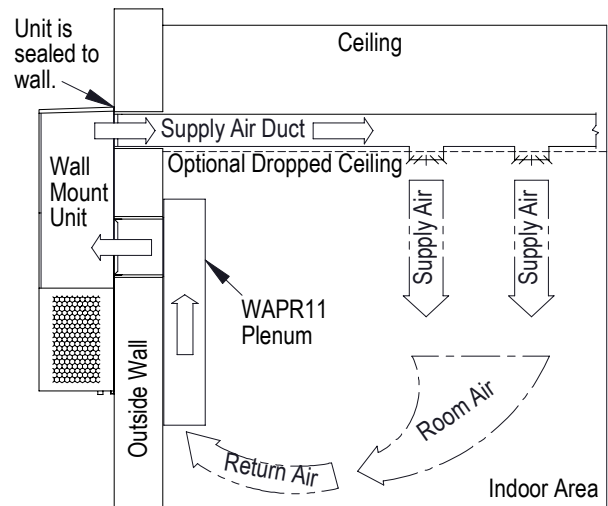

Indoor sound plenums are installed inside the room over the unit return air opening. Plenum use can provide sound isolation and indoor area sound reduction. The WAPR11 sound plenum provides a single solution for all unit tonnage sizes. The WAPR11 may be installed horizontally or vertically in the room. Unit duct static requirements cannot be exceeded when using a sound plenum. Follow all instructions provided with the sound plenum when installing the product.

MIS-550 D

Wiring – Main Power

WARNING

Electrical shock hazard.

Do not operate this equipment without an earth ground attached and always disconnect the remote electric power supplies before servicing.

Electrical shock can result in serious injury or death.

Main electrical power must be supplied to the unit from a clean, reliable power source. Verify voltage being supplied to the unit is consistent during all times of the day and within the range specified for the unit in the unit specifications and on the unit serial plate. Voltage must be measured at the field power connection point in the unit and while the unit is operating at full load (maximum amperage operating condition).

Refer to the unit serial plate for maximum fuse or circuit breaker size. Reference the unit specification sheet for wire sizing information. Each outdoor unit is marked with a “Minimum Circuit Ampacity”. This means that the field wiring used must be sized to carry that amount of current. Depending on the installed kW of electric heat, there may be two field power circuits required. If this is the case, the unit serial plate will so indicate.

All models are suitable only for connection with copper wire. Each unit and/or wiring diagram will be marked “Use Copper Conductors Only”. These instructions must be adhered to. Refer to the National Electrical Code (NEC) for complete current carrying capacity data on the various insulation grades of wiring material. All wiring must conform to NEC and all local codes.

The electrical data on the serial plate, in the unit specifications and also in Table 14 on page 51 list fuse sizes for all models including the most commonly used heater sizes. Also shown are the number of field power circuits required for the various models with heaters. The unit rating plate lists a “Maximum Time Delay Relay Fuse” or circuit breaker that is to be used with the equipment. The correct type and size must be used for proper circuit protection and also to ensure that there will be no nuisance tripping due to the momentary high starting current of the compressor motor.

Three phase models must have proper phasing. A phase monitor is included in all three phase models, and will indicate improper phasing during a call for heating or cooling (24VAC at Y1 terminals). See provided information included in this document regarding the phase monitor.

High Voltage Connections

Route field wires under the field wire shield shown in Figure 19. (The field wire shield can be removed for wire installation.) If field power is supplied to the left side of the unit, run the high voltage wires under the shield shown in Figure 19 and to the right of the wire shield next to the compressor contactor and up into the upper

FIGURE 19
High Voltage Connections

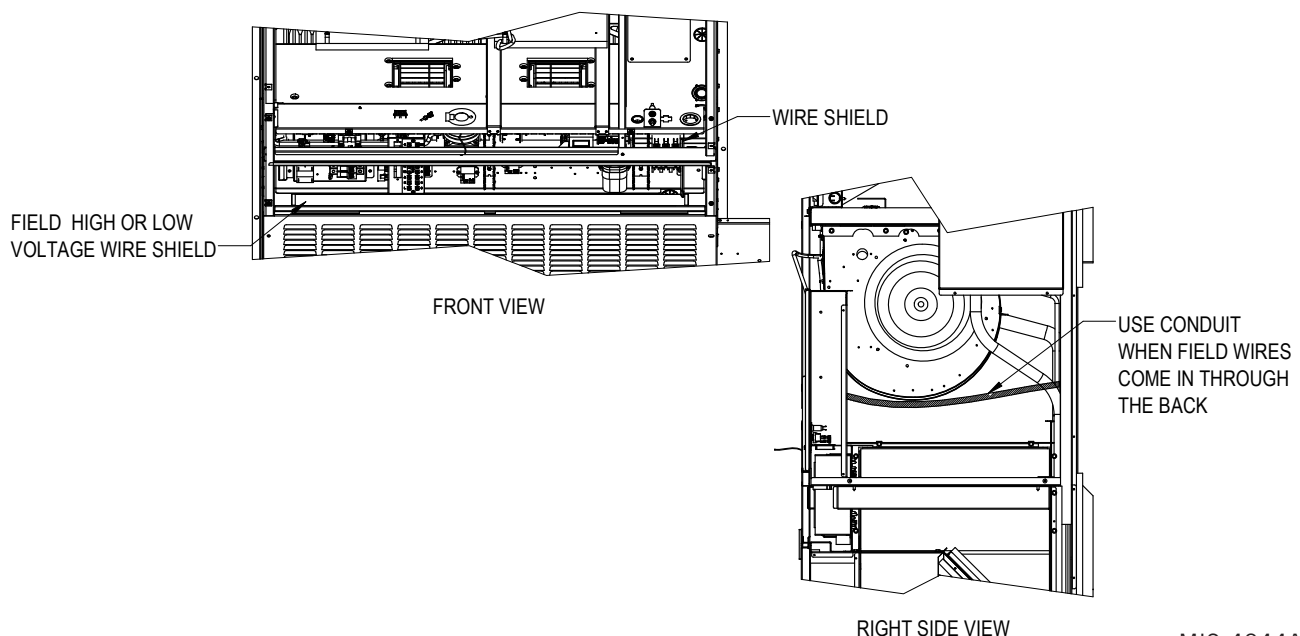

MIS-4044A

control panel where the connections are made. (The field wire shield can be removed for wire installation.) If field power is supplied to the right of side of the unit, the low voltage wires can be run under the field wire shield to access the low voltage terminal strip.

When field wires are supplied through the back of the unit, flexible conduit must be extended through the back of the unit and terminate into the knock-outs on the upper control panel (see Figure 19).

Wiring – Low Voltage

All 1-phase and 3-phase equipment, rated 230/208V, have dual primary voltage terminals on the low-voltage, step-down transformer. The equipment leaves the factory wired on 240V tap. For 208V operation, reconnect from 240V to 208V tap. The acceptable operating voltage range for the 240 and 208V taps are:

Tap: 240 Range: 253 – 216

Tap: 208 Range: 215 – 197

NOTE: *The voltage should be measured at the field power connection point in the unit and while the unit is operating at full load (maximum amperage operating condition).*

For low voltage wiring, an 18 gauge copper, color-coded cable is recommended. See Table 6 on page 28 for more information.

Low Voltage Connections

These units use a 24-volt AC low voltage circuit.

R terminal is the *24VAC hot*.

C terminal is the *24VAC common and is grounded*.

G terminal is the *indoor blower input*.

Y1 terminal is the *compressor part load input*.

Y2 terminal is the *compressor full load input*.

B/W1 terminal is the *reversing valve input*. The reversing valve must be energized for heating mode.

W2 terminal is the *1st stage electric heat* (if equipped). 1st stage electric heat can be operated simultaneously with the heat pump operating.

W3 terminal is the *2nd stage of electric heat or emergency heat* (if equipped). When W3 terminal is energized, it locks out compressor operation to limit discharge air temperature and required branch circuit ampacity.

A terminal is the *ventilation input*. This terminal energizes any factory-installed ventilation option and indoor blower.

L terminal is *24 volt alarm active output*.

For units equipped with an alarm relay:

1 terminal is the *normally closed contact on the relay*.

2 terminal is the *normally open contact on the relay*.

3 terminal is the *common contact on the relay*.

Unit Shutdown Feature (Standard on All Models)

The RT terminal is the 24VAC transformer output, and the R terminal is the 24VAC hot terminal for the operation of the equipment. RT and R are connected with a brass jumper bar which can be removed and RT and R connected to an external NC (normally closed) contact such as a fire/smoke detector that will cause shutdown of the equipment upon activation.

Dehumidification Feature (Optional)

The D terminal is the 24VAC input for dehumidification operation on dehumidification hot gas reheat equipped units. When 24VAC is applied to the D terminal, a 3-way valve solenoid is energized. The reheat coil located behind the evaporator coil is then active to reheat the supply air during cooling mode. This allows humidity to be removed from the air entering the unit without a large amount of sensible cooling capacity. During dehumidification, the indoor blower speed is reduced to help with the humidity removal. A humidity sensing thermostat or humidistat is required to control dehumidification operation.

If there is a call for dehumidification and comfort cooling at the same time, the call for cooling takes precedent over dehumidification.

Ventilation Features (Optional)

See ventilation instructions provided with unit for low voltage wiring.

TABLE 3
Field Supplied Controls – Sequence of Operation

Fan Only	Energize G
Cooling Mode 1st Stage	Energize G, Y1
Cooling Mode 2nd Stage	Energize G, Y1, Y2
Heat Pump Heating 1st Stage	Energize G, Y1, B/W1
Heat Pump Heating 2nd Stage	Energize G, Y1, Y2, B/W1
HP Heating FL + EH (Up to 10 kW)	Energize G, W2, Y1, Y2, B/W1
Heat Bank #1 (EH Only)	Energize G, W2
Emergency Heat (HP operation is negated for this condition)	Energize, G, W2, W3
Dehumidification (if employed)	Energize D
Ventilation	Energize A

Low Ambient Control (LAC)

The low ambient control is a pressure switch that is attached to the liquid line of the system and monitors

high side system pressure. Operation of the LAC occurs as outdoor temperatures drop below 60°F. LAC operation cycles the condenser fan on/off based on outdoor temperature.

The LAC kit also comes with an evaporator freeze protection thermostat that cuts out the compressor if the evaporator begins to freeze up.

If the unit is being installed with any ventilation package, a Bard LAC kit must be installed. Failure to utilize an LAC with any heat pump can cause coil freeze up.

Freeze Protection Thermostat

An evaporator freeze protection thermostat is supplied with all units that have a low ambient control. The freeze thermostat cuts out compressor operation if the evaporator begins to freeze up.

Alarm Relay Feature (Controls Option)

The alarm relay provides a set of NO (normally open) and NC (normally closed) pilot duty contacts that operate when the defrost board locks out compressor operation because of a high or low system refrigerant pressure event.

Dirty Filter Switch Indicator (DFS)

The switch is adjustable and measures pressure drop across the unit filter surface. When pressure drop is higher than the switch setting, NO contacts are provided to indicate the filter needs to be serviced. Refer to page 52 for instructions on making switch adjustments.

Refrigerant Leak Detection System (RDS)

The RDS continuously monitors air in the indoor section of the unit for leaked refrigerant. In the event of a refrigerant leak, the RDS will initiate mitigation actions to disperse the refrigerant and prevent potentially dangerous refrigerant concentration levels. The RDS will also provide a 24VAC alarm output signal on the "L" terminal of the unit low-voltage terminal strip.

Refer to page 43 for more information.

**TABLE 4
Humidity Controls**

Part Number	Predominate Features
8403-100* (H6062A1000)	Electronic humidistat DPST Humidity range 10-90% with adjustable stops
8403-047 (H200-10-21-10)	Electronic dehumidistat SPST closes-on-rise; Humidity range 10-90% with adjustable stops

* If using Honeywell HumidiPRO (H6062A1000) 8403-100 humidistat, it must be configured for dehumidification in the menu.

**TABLE 5
Wall Thermostats**

Thermostat	Predominant Features
8403-060 (1120-445)	3 Stage Cool, 3 Stage Heat Programmable/Non-Programmable Electronic HP or Conventional Auto or Manual Changeover Dehumidification Output
8403-081 (BrightStat)	2 Stage Cool, 2 Stage Heat Programmable/Non-Programmable Electronic HP or Conventional Auto or Manual Changeover with Humidity and Occupancy Sensor BACnet (Thermostat option only permissible for units up to 12 kW electric heat)
8403-083 (BrightStat)	2 Stage Cool, 2 Stage Heat Programmable/Non-Programmable Electronic HP or Conventional Auto or Manual Changeover with Humidity (only) BACnet (Thermostat option only permissible for units up to 12 kW electric heat)
8403-090 (T6 Pro)	2 Stage Cool, 3 Stage Heat – Heat Pump 2 Stage Cool, 2 Stage Heat – Conventional Programmable/Non-Programmable Electronic Auto or Manual Changeover
8403-092 (T6 Pro Wi-Fi)	2 Stage Cool, 3 Stage Heat – Heat Pump 2 Stage Cool, 2 Stage Heat – Conventional Programmable/Non-Programmable Electronic Auto or Manual Changeover Wi-Fi

**TABLE 6
Thermostat Wire Size**

Transformer VA	FLA	Wire Gauge	Maximum Distance In Feet
55	2.3	18 gauge 16 gauge 14 gauge 12 gauge	60 100 160 250

**TABLE 7
CO₂ Controllers**

Part Number	Predominate Features
8403-096	Normally Open SPST relay closes-on-rise 24V dual wave length sensor. Default setting 950ppm, adjustable to 0-2000ppm Default off setting 1000ppm, adjustable to 0-200 ppm can be calibrated

FIGURE 20
Programmable Thermostat Connections

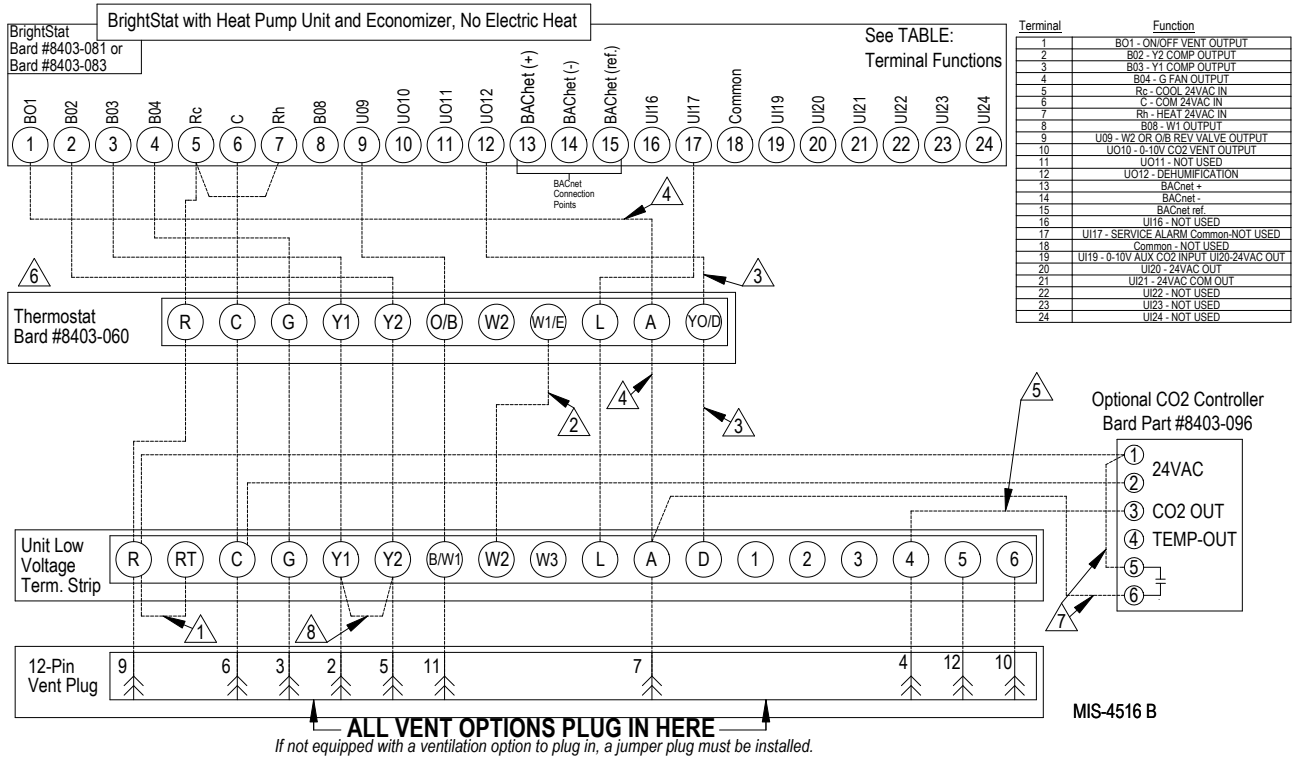

ALL VENT OPTIONS PLUG IN HERE
If not equipped with a ventilation option to plug in, a jumper plug must be installed.

- 1 Factory installed jumper. Remove jumper and connect to N.C fire alarm circuit if emergency shutdown required.
- 2 Outdoor thermostat controls option required for 12kW to 15kW electric heat and use of Brightstat.
- 3 Wire required for dehumidification models only.
- 4 Do not connect "A" from thermostat if optional CO2 controller is used
- 5 0-10 VDC modulating CO2 control signal for modulating ventilation control (optional for ECON only - see vent instruction manuals)
- 6 Ensure model configuration is heat pump and not heat/cool. Must be configured to programmable and fan set to be programmed fan for the "A" output to function during scheduled occupied periods. Must be configured for multi-stage for Y1 output to be active 1st stage cooling. For dehumidification, must be configured for "No Economizer" for YO/D to be active for humidity control.
- 7 Do not add these wires if setting up for modulating control.
- 8 Factory installed jumper. Remove jumper to activate Balanced Climate TM Mode. A 2-stage thermostat is recommended for balanced climate mode. Y1 Y2 jumper not present if economizer is factory installed. Units with economizers have balanced climate jumper in economizer, refer to economizer manual. The jumper is factory removed in the unit and on jade for C**H models.

FIGURE 21
Programmable Thermostat Connections

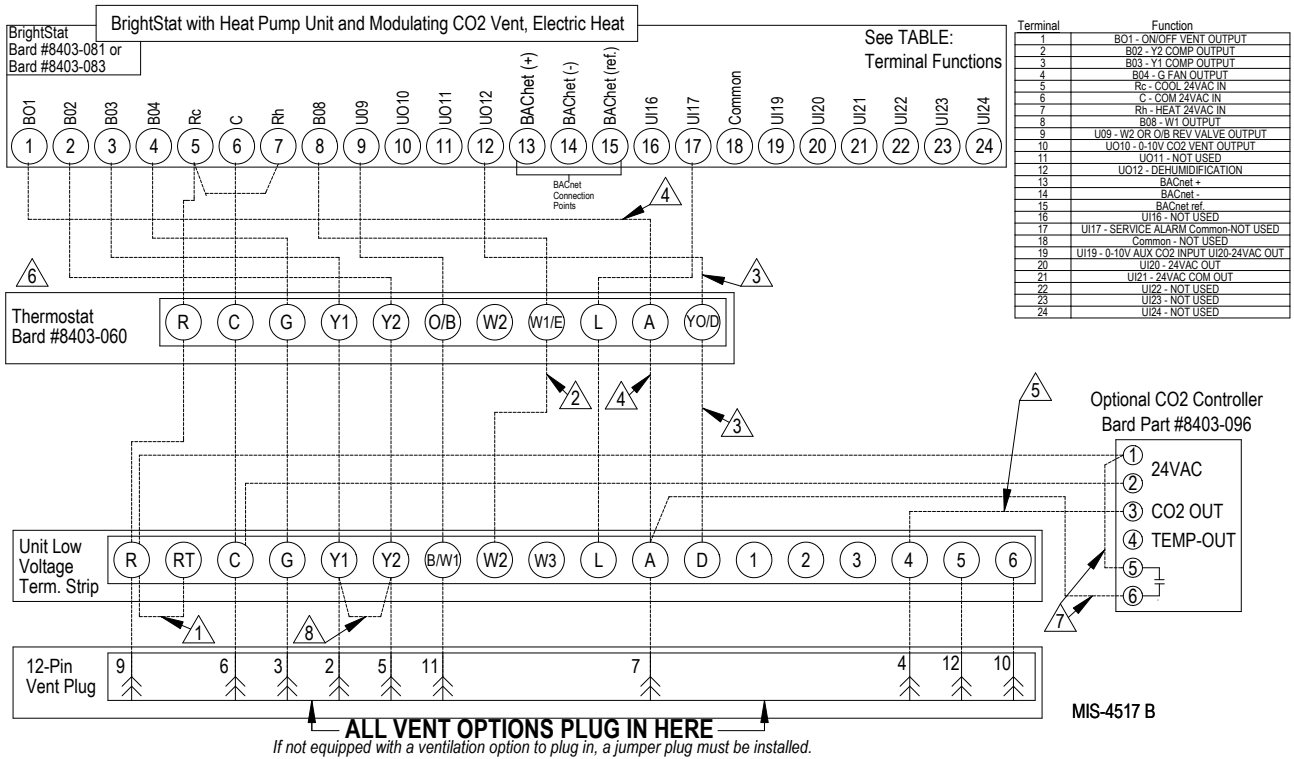

- 1 Factory installed jumper. Remove jumper and connect to N.C fire alarm circuit if emergency shutdown required.
- 2 Outdoor thermostat controls option required for 12kW to 15kW electric heat and use of Brightstat.
- 3 Wire required for dehumidification models only.
- 4 Do not connect "A" from thermostat if optional CO2 controller is used
- 5 0-10 VDC modulating CO2 control signal for modulating ventilation control (optional for ECON only - see vent instruction manuals)
- 6 Ensure model configuration is heat pump and not heat/cool. Must be configured to programmable and fan set to be programmed fan for the "A" output to function during scheduled occupied periods. Must be configured for multi-stage for Y1 output to be active 1st stage cooling. For dehumidification, must be configured for "No Economizer" for YO/D to be active for humidity control.
- 7 Do not add these wires if setting up for modulating control.
- 8 Factory installed jumper. Remove jumper to activate Balanced Climate TM Mode. A 2-stage thermostat is recommended for balanced climate mode. Y1 Y2 jumper not present if economizer is factory installed. Units with economizers have balanced climate jumper in economizer, refer to economizer manual. The jumper is factory removed in the unit and on jade for C**H models.

FIGURE 22
Non-Programmable Thermostat Connections

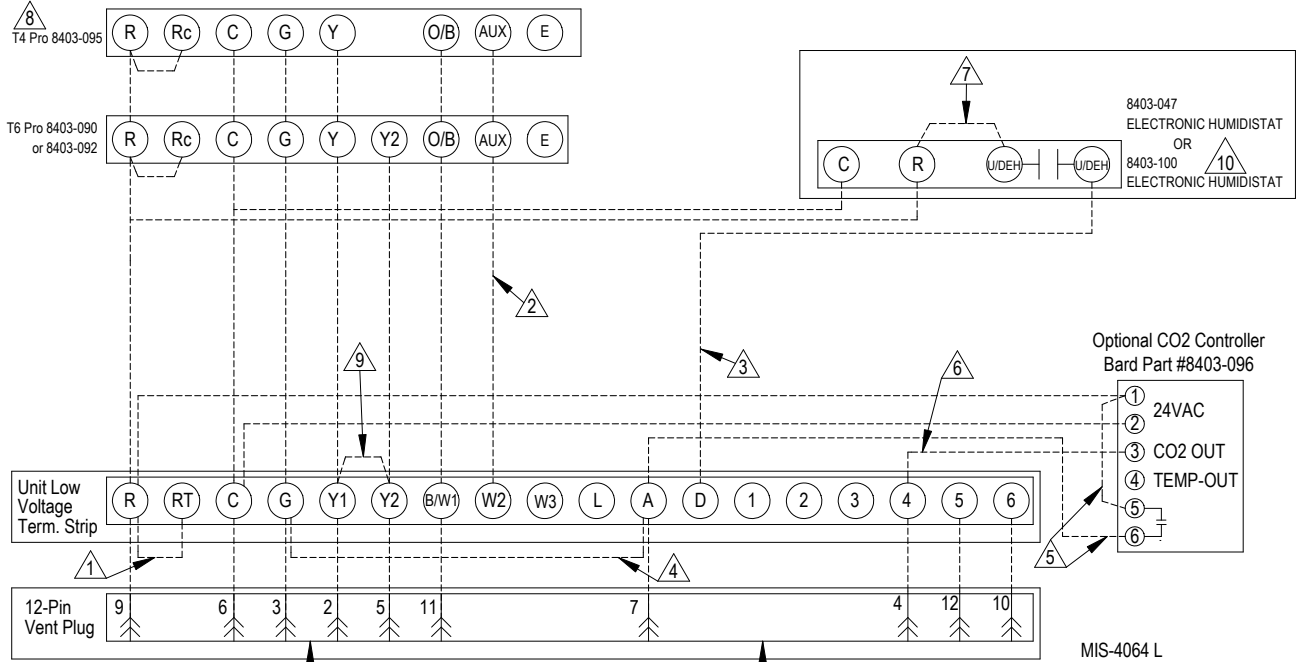

ALL VENT OPTIONS PLUG IN HERE

If not equipped with a ventilation option to plug in, a jumper plug must be installed.

- ⚠️ 1. FACTORY INSTALLED JUMPER. REMOVE JUMPER AND CONNECT TO N.C FIRE ALARM CIRCUIT IF EMERGENCY SHUTDOWN REQUIRED.
- ⚠️ 2. AUX WILL ENERGIZE SECOND HEAT CONTACTOR IF COMPRESSOR IS NOT ACTIVE. THERMOSTAT SELECTED SHALL NOT ALLOW SIMULTANEOUS OUTPUT ON "Y" WHEN "W2" IS ENERGIZED.
- ⚠️ 3. WIRE REQUIRED FOR DEHUMIDIFICATION MODELS ONLY.
- ⚠️ 4. FOR VENT OPERATION, ADD JUMPER IF OPTIONAL CO2 CONTROLLER IS NOT USED. VENT WILL RUN WHILE BLOWER IS ENERGIZED. FOR ECON & CRV-V, AN ADDITIONAL WIRE CHANGE IS REQUIRED. SEE INSTALL MANUAL.
- ⚠️ 5. DO NOT ADD THESE WIRES IF SETTING UP FOR MODULATING CONTROL. SEE NOTE 6.
- ⚠️ 6. 0-10 VDC MODULATING CO2 CONTROL SIGNAL FOR MODULATING VENTILATION CONTROL (OPTIONAL FOR ECON ONLY) - SEE VENT INSTALLATION MANUAL.
- ⚠️ 7. JUMPER NEEDS ADDED.
- ⚠️ 8. THERMOSTAT IS INCOMPATIBLE WITH SYSTEMS THAT ARE EQUIPPED WITH ECONOMIZERS. MEANING IF THE UNIT HAS AN ECONOMIZER, THE THERMOSTAT WILL NOT FUNCTION PROPERLY WITH AN ECONOMIZER.
- ⚠️ 9. FACTORY INSTALLED JUMPER. REMOVE JUMPER TO ACTIVATE BALANCED CLIMATE™ MODE. A 2-STAGE THERMOSTAT IS RECOMMENDED FOR BALANCED CLIMATE MODE. Y1 Y2 JUMPER NOT PRESENT IF ECONOMIZER IS FACTORY INSTALLED. UNITS WITH ECONOMIZERS HAVE BALANCED CLIMATE JUMPER IN ECONOMIZER. REFER TO ECONOMIZER MANUAL. THE JUMPER IS FACTORY REMOVED IN THE UNIT AND ON JADE FOR C**HY MODELS.
- ⚠️ 10. HUMIDISTAT 8403-100 WILL NEED TO BE CONFIGURED FOR DEHUMIDIFICATION IN THE MENU. SEE USER'S MANUAL.

START UP

NOTICE

These units require R-454B refrigerant and polyol ester oil.

General

1. R-454B refrigerant is classified as an A2L, or mildly flammable refrigerant. Refer to A2L Refrigerant Safety Manual 2100-810 for information regarding safe practices for charging, reclaim, decommissioning and general handling of A2L refrigerants.
2. Use separate service equipment to avoid cross contamination of oil and refrigerants.
3. Use recovery equipment rated for R-454B refrigerant.
4. Use manifold gauges rated for R-454B (800 psi/250 psi low).
5. R-454B is a zeotropic blend of HFC-32 and HFO-1234yf. Charge with liquid refrigerant.
6. R-454B has an ozone depletion potential of zero, but must be reclaimed due to its global warming potential.
7. R-454B compressors use polyol ester oil.
8. Polyol ester oil is hygroscopic; it will rapidly absorb moisture and strongly hold this moisture in the oil.
9. A liquid line dryer must be used—even a deep vacuum will not separate moisture from the oil.
10. Limit atmospheric exposure to 15 minutes.
11. If compressor removal is necessary, always plug compressor immediately after removal. Purge with small amount of nitrogen when inserting plugs.

Topping Off System Charge

If a leak has occurred in the system, Bard Manufacturing recommends reclaiming, evacuating (see manual 2100-810) and charging to the nameplate charge.

Since R-454B is a zeotropic blend, one component may leak off before another component in the event of a leak. This can cause significant changes to the concentration of each component in the system. For this reason, Bard Manufacturing does not recommend topping off the system charge.

REMEMBER: When adding R-454B refrigerant, it must come out of the charging cylinder/tank as a liquid to avoid any fractionation, and to ensure optimal system performance. Refer to instructions for the cylinder that is being utilized for proper method of liquid extraction.

WARNING

Failure to conform to these practices could lead to damage, injury or death.

Safety Practices

1. Never mix R-454B with other refrigerants.
2. Use gloves and safety glasses. Polyol ester oils can be irritating to the skin, and liquid refrigerant will freeze the skin.
3. Never use air and R-454B to leak check; the mixture is flammable.
4. Do not inhale R-454B—the vapor attacks the nervous system, creating dizziness, loss of coordination and slurred speech. Cardiac irregularities, unconsciousness and ultimate death can result from breathing this concentration.
5. Do not burn R-454B. This decomposition produces hazardous vapors. Evacuate the area if exposed.
6. Use only cylinders rated DOT4BA/4BW 400.
7. Never fill cylinders over 80% of total capacity.
8. Store cylinders in a cool area, out of direct sunlight.
9. Never heat cylinders above 125°F.
10. Never trap liquid R-454B in manifold sets, gauge lines or cylinders. R-454B expands significantly at warmer temperatures. Once a cylinder or line is full of liquid, any further rise in temperature will cause it to burst.

Important Installer Note

For improved start-up performance, wash the indoor coil with dishwasher detergent.

High Pressure Switch

All C**HF wall-mounted heat pump series models are supplied with a remote reset for the high and low pressure switches. If tripped, the pressure switch may be reset by turning the thermostat off then back on again. High pressure switch settings: Opens 615 +/- 15 PSI, Closes 490 +/- 15 PSI.

Three Phase Scroll Compressor Start Up Information

Scroll compressors, like several other types of compressors, will only compress in one rotational direction. Upon start up, direction of rotation is not an issue with single phase compressors since they will always start and run in the proper direction.

However, three phase compressors will rotate in either direction depending upon phasing of the power. Since there is a 50-50 chance of connecting power in such a way as to cause rotation in the reverse direction, verification of proper rotation must be made. Verification of proper rotation direction is made by observing that suction pressure drops and discharge pressure rises when the compressor is energized. Reverse rotation also results in an elevated sound level over that with correct rotation, as well as substantially reduced current draw compared to tabulated values.

Verification of **proper rotation** must be made at the time the equipment is put into service. If improper rotation is corrected at this time, there will be no negative impact on the durability of the compressor. However, reverse operation for over 1 hour may have a negative impact on the bearing due to oil pump out.

NOTE: *If compressor is allowed to run in reverse rotation for an extended period of time, the compressor's internal protector will trip.*

All three phase compressors are wired identically internally. As a result, once the correct phasing is determined for a specific system or installation, connecting properly phased power leads to the same Fusite terminal should maintain proper rotation direction.

The direction of rotation of the compressor may be changed by reversing any two line connections to the unit.

Phase Monitor

All units with three phase scroll compressors are equipped with a three phase line monitor to prevent compressor damage due to phase reversal.

The phase monitor in this unit is equipped with two LEDs. If the Y signal (call for cooling) is present at the phase monitor and phases are correct, the green LED will light.

NOTE: *The phase monitor will not show phase reversal until the compressor is energized during a call for cooling or heat pump operation.*

If phases are reversed, the red fault LED will be lit and compressor operation is inhibited.

If a fault condition occurs, reverse two of the supply leads to the unit. **Do not reverse any of the unit factory wires as damage may occur.**

Condenser Fan Operation

NOTE: *Certain models may be equipped with a low ambient control (LAC), and if so, the condenser fan motor will have a delayed start until system refrigerant operating pressure builds up. After starting, the fan motor may or may not cycle depending upon ambient conditions. This is normal operation.*

Service Hints

1. Caution owner/operator to maintain clean air filters at all times and also not to needlessly close off supply and return air registers. This reduces airflow through the system, which shortens equipment service life as well as increasing operating costs.
2. Switching to heating cycle at 75°F or higher outside temperature may cause a nuisance trip of the remote reset high pressure switch. Turn thermostat off, then on to reset the high pressure switch.
3. Heat pump wall thermostats perform multiple functions. Be sure that all function switches are correctly set for the desired operating mode before trying to diagnose any reported service problems.
4. Check all power fuses or circuit breakers to be sure they are the correct rating.
5. Periodic cleaning of the outdoor coil to permit full and unrestricted airflow circulation is essential.
6. Annual maintenance is required to make sure that all of the systems are functioning properly.
 - a. Check to make sure that the drains are not obstructed in any way.
 - b. Remove any debris in the condenser section of the unit.
 - c. Inspect and wash outdoor coils as necessary.
7. All motors are sealed and require no oiling.

Sequence of Operation

Cooling Stage 1

Circuit R-Y1 makes at thermostat pulling in compressor contactor, starting the compressor and outdoor motor. (See **NOTE** under **Condenser Fan Operation** concerning models equipped with low ambient control.) The G (indoor motor) circuit is automatically completed by the thermostat on any call for cooling operation or can be energized by manual fan switch on subbase for constant air circulation.

Cooling Stage 2

Circuit R-Y1 & Y2 makes at the thermostat energizing the 2nd stage solenoid in the compressor. The default position of the compressor staging solenoid is non-energized. The compressor will run at low capacity until this solenoid is energized.

NOTE: The C60H is equipped with a two speed ECM fan motor. High speed is used in cooling stage 2 and low speed is used in all other modes of operation.

Heating Stage 1

A 24V solenoid coil on reversing valve controls heating cycle operation. Two thermostat options, one allowing "Auto" changeover from cycle to cycle and the other constantly energizing solenoid coil during heating season and thus eliminating pressure equalization noise except during defrost, are to be used. On "Auto" option, a circuit is completed from R-B and R-Y1 on each heating "on" cycle, energizing reversing valve solenoid and pulling in compressor contactor starting compressor and outdoor motor. R-G also make starting indoor blower motor. Heat pump heating cycle now in operation. The second option has no "Auto" changeover position, but instead energizes the reversing valve solenoid constantly whenever the system switch on thermostat is placed in "Heat" position, the "B" terminal being constantly energized from R. A thermostat demand for Stage 1 heat completes R-Y1 circuit, pulling in compressor contactor starting compressor and outdoor motor. R-G also make starting indoor blower motor.

Heating Stage 2

Circuit R-Y1 & B continue to be energized. Circuit R-Y2 makes at the thermostat energizing the 2nd stage solenoid in the compressor.

Heating Stage 2 and Electric Heat (Up to 10 kW)

Circuit R-Y1, Y2 & B continue to be energized for heating stage 2. On the a call for electric heat, circuit R-W2 makes at the thermostat, pulling in the heat contactor for the strip heat.

Emergency Heat

The thermostat, or outdoor thermostat option, drops out the heat pump call. Circuit R-W2 continues to be energized. Upon the dropping out of the compressor signal, the emergency heat relay pulls in the second heat contactor, if equipped.

Low Ambient Conditions

If the application is likely to require air conditioning operation below 60°F outdoor conditions, a low ambient control (LAC) kit must be installed. The LAC kit also comes with an evaporator freeze protection thermostat that cuts out the compressor if the evaporator begins to freeze up.

If the unit is being installed with any ventilation package, a Bard LAC kit must be installed. Failure to utilize an LAC with any heat pump can cause coil freeze up.

Defrost Cycle

The defrost cycle is controlled by temperature and time on the solid state heat pump control (see Figure 23).

When the outdoor temperature is in the lower 40°F temperature range or colder, the outdoor coil temperature is 32°F or below. This coil temperature is sensed by the coil temperature sensor mounted near the bottom of the outdoor coil. Once coil temperature reaches 30°F or below, the coil temperature sensor sends a signal to the control logic of the heat pump control and the defrost timer will start accumulating run time.

After 30, 60 or 90 minutes of heat pump operation at 30°F or below, the heat pump control will place the system in the defrost mode. Factory default setting is 60 minutes.

During the defrost mode, the refrigerant cycle switches back to the cooling cycle, the outdoor motor stops, electric heaters are energized and hot gas passing through the outdoor coil melts any accumulated frost. When the temperature rises to approximately 57°F, the coil temperature sensor will send a signal to the heat pump control which will return the system to heating operations automatically.

If some abnormal or temporary condition such as a high wind causes the heat pump to have a prolonged defrost cycle, the heat pump control will restore the system to heating operation automatically after 8 minutes.

The heat pump defrost control board has an option of 30-, 60- or 90-minute setting. By default, this unit is shipped from the factory with the defrost time on the 60-minute pin. If circumstances require a change to another time, remove the jumper pin from the 60-minute terminal and reconnect to the desired terminal. Refer to Figure 23.

There is a cycle speed up jumper on the control. This can be used for testing purposes to reduce the time between defrost cycle operation without waiting for time to elapse.

Use a small screwdriver or other metallic object, or another 1/4" QC, to short between the *SPEEDUP* terminals to accelerate the HPC timer and initiate defrost.

Be careful not to touch any other terminals with the instrument used to short the *SPEEDUP* terminals. It may take up to 15 seconds with the *SPEEDUP* terminals shorted for the speedup to be completed and the defrost cycle to start.

As soon as the defrost cycle kicks in, remove the shorting instrument from the SPEEDUP terminals. Otherwise the timing will remain accelerated and run through the 1-minute minimum defrost length sequence in a matter of seconds and will automatically terminate the defrost sequence.

There is an initiate defrost jumper (*SEN JMP*) on the control that can be used at any outdoor ambient during the heating cycle to simulate a 0°F coil temperature.

FIGURE 23
Defrost Control Board

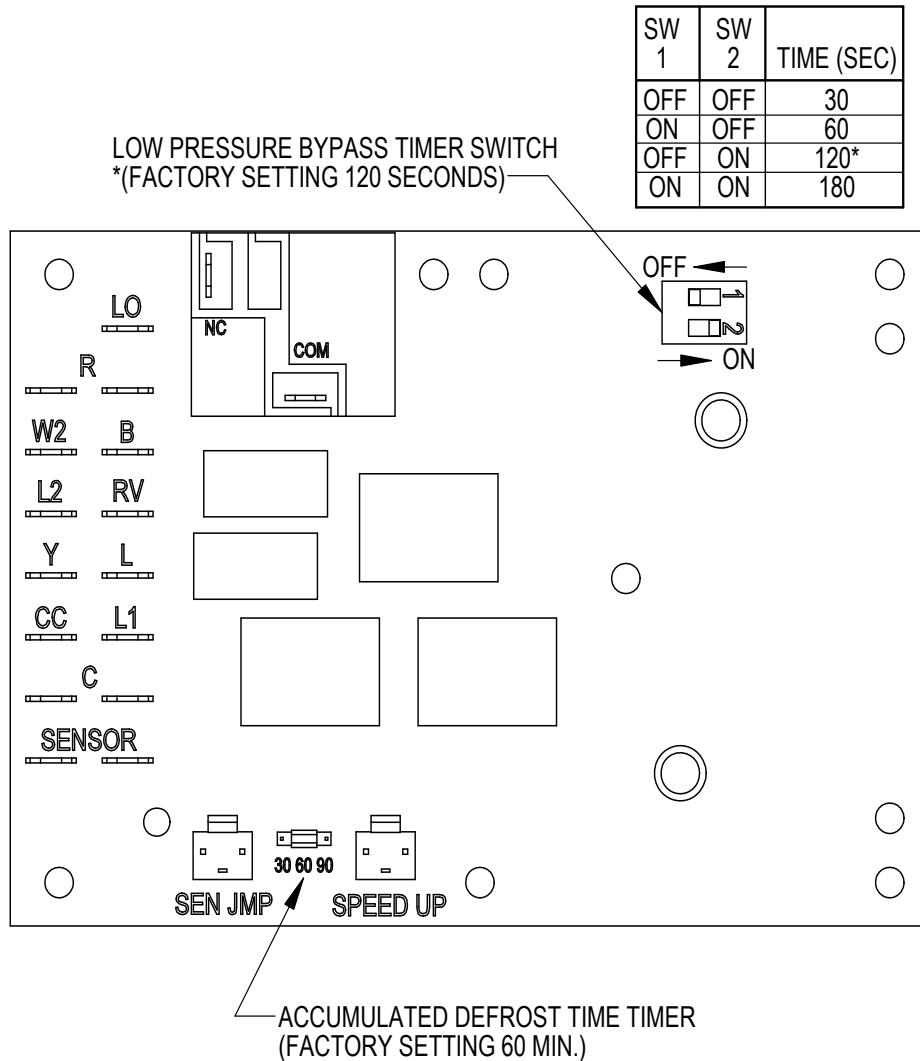

Model	Setting
C36HF	60
C42HF	60
C48HF	60
C60HF	60

MIS-2668 A

This can be used to check defrost operation of the unit without waiting for the outdoor ambient to fall into the defrost region.

By placing a jumper across the *SEN JMP* terminals (a 1/4" QC terminal works best) the defrost sensor mounted on the outdoor coil is shunted out and will activate the timing circuit. This permits the defrost cycle to be checked out in warmer weather conditions without the outdoor temperature having to fall into the defrost region.

In order to terminate the defrost test, the SEN JMP jumper must be removed. If left in place too long, the compressor could stop due to the high pressure control opening because of high pressure condition created by operating in the cooling mode with outdoor fan off. Pressure will rise rapidly as there is likely no actual frost on the outdoor coil in this artificial test condition.

There is also a 5-minute compressor time delay function built into the Heat Pump Control to protect the compressor from short cycling conditions. The board's

LED will have a fast blink rate when in the compressor time delay. In some instances, it is helpful to the service technician to override or speed up this timing period and shorting out the *SPEEDUP* terminals for a few seconds can do this.

Low Pressure Switch Bypass Operation

The control has a selectable (SW1) low pressure switch bypass set up to ignore the low pressure switch input during the first (30, 60, 120 or 180 seconds) of “Y1” signal from thermostat.

After this period expires, the control will then monitor the low pressure switch input normally to make sure that the switch is closed during “Y” operation (defrost control board).

High Pressure Switch Operation

The control has a built-in lockout system that allows the unit to have the high pressure switch trip up to two times in 1 hour and only encounter a “soft” lockout. A “soft” lockout shuts the compressor off and waits for the pressure switch to reset, which at that point then allows the compressor to be restarted as long as the 5-minute short cycle timer has run out. If the high pressure switch trips a third time within 1 hour, the unit is in “hard” lockout indicating something is certainly wrong and it will not restart itself.

Vent Connection Plug

All units are equipped with a vent connection plug in the side of the control panel for the different ventilation packages to plug in to. If the compressor will not start and there is no “Y1” at the defrost board, first check to make sure that either the optional vent is plugged into the vent connection plug or the supplied jumper plug is in place. **The unit will not operate without anything plugged in.** This plug is located on the side of the control panel behind the front vent door (behind the filter access door). If the unit is supplied with a factory-installed vent package, it will be plugged in but the jumper plug will also be tethered next to the connection for troubleshooting purposes, if necessary.

Pressure Service Ports

High and low pressure service ports are installed on all units so that the system operating pressures can be observed. Pressure tables covering all models can be found on pages 48, 49 and 50. It is imperative to match the correct pressure table to the unit by model number.

This unit employs high-flow Coremax valves instead of the typical Schrader type valves.

WARNING! Do NOT use a Schrader valve core removal tool with these valves. Use of such a tool could result in eye injuries or refrigerant burns!

To change a Coremax valve without first removing the refrigerant, a special tool is required which can be obtained at www.fastestinc.com/en/SCCA07H. See the replacement parts manual for replacement core part numbers.

Solid State Heat Pump Control Troubleshooting Procedure

1. **NOTE:** A thorough understanding of the defrost cycle sequence is essential. Review that section (page 30) prior to troubleshooting the control. Turn on AC power supply to unit.
2. Turn thermostat blower switch to “fan on”—the indoor blower should start. (If it doesn’t, troubleshoot indoor unit and correct problem.)
3. Turn thermostat blower to “auto” position. Indoor blower should stop. **NOTE:** Many models have a 1-minute blower time delay on “off” command; wait for this to time out.
4. Set system switch to “heat” or “cool”. Adjust thermostat to call for heat or cool. The indoor blower, compressor and outdoor fan should start.

NOTE: If there was no power to 24 volt transformer, the compressor and outdoor fan motor will not start for 5 minutes. This is because of the compressor short cycle protection.

LED BLINK CODES	
BLINK	FUNCTION
Slow	Normal function (1.0 sec on/1.0 sec off)
Fast	Compressor Delay timer active (0.1 sec on/0.1 sec off)
1	Low pressure switch failure
2	High pressure switch failure/“Soft” Lockout
3	Defrost mode active
4	High pressure switch failure/“Hard” Lockout

TABLE 8 – Troubleshooting

Symptom	Description, Check and Possible Causes	What & How to Check / Repair
Compressor will not start (heating or cooling)	1. Check for LED illumination. Is there an LED illuminated on the board (flashing)?	Yes = go to Step #2; No = go to Step #3
	2. Check for error codes. Is the LED flashing a Code?	Yes = go to Step #4; No = go to Step #8
	3. Check for power at board. Is there 24 volts AC between R and C?	Yes = go to Step #13; No = go to Step #9
	4. Check codes. What code is blinking?	Code "1", go to Step #6; Code "2", go to Step #7; Fast Blink, go to Step #5
	5. Compressor delay active. Wait for 5 minute delay or jump board's "speed up pins".	Check for proper operation; if still needed, go back to Step #1.
	6. Low pressure fault.	Check wiring circuit and unit pressures.
	7. High pressure fault.	Check wiring circuit and unit pressures.
	8. Check for Compressor input signal. Is there 24 volts AC between Y and C?	Yes = go to Step #10; No = go to Step #11
	9. No power to board.	The unit either does not have unit voltage, the transformer is bad or the unit wiring is incorrect.
	10. Check for Compressor output signal. Is there 24 volts AC between CC & C?	Yes = go to Step #12; No = go to Step #13
	11. No "Y" compressor input signal.	Check thermostat wiring, incorrect phase of unit (see section on Phase Monitor), and finally unit wiring.
	12. No "CC" compressor output signal.	Check compressor contactor for proper operation and finally check compressor.
	13. Faulty board.	Replace defrost board.
Fan outdoor motor does not run (cooling or heating except during defrost)	Heat pump control defective	Check across fan relay on heat pump control. (Com-NC) Replace heat pump control.
	Motor defective	Check for open or shorted motor winding. Replace motor.
	Motor capacitor defective	Check capacitor rating. Check for open or shorted capacitor. Replace capacitor.
Reversing valve does not energize (heating only)	Heat pump control defective	Check for 24V between RV-C and B-C. 1. Check control circuit wiring. 2. Replace heat pump control.
	Reversing valve solenoid coil defective	Check for open or shorted coil. Replace solenoid coil.
Unit will not go into defrost (heating only)	Temperature sensor or heat pump control defective	Disconnect temperature sensor from board and jumper across "SPEEDUP" terminals and "SEN JMP" terminals. This should cause the unit to go through a defrost cycle within one minute. 1. If unit goes through defrost cycle, replace temperature sensor. 2. If unit does not go through defrost cycle, replace heat pump control.
Unit will not come out of defrost (heating only)	Temperature sensor or heat pump control defective	Jumper across "SPEEDUP" terminal. This should cause the unit to come out of defrost within one minute. 1. If unit comes out of defrost cycle, replace temperature sensor. 2. If unit does not come out of defrost cycle, replace heat pump control.

Checking Temperature Sensor Outside Unit Circuit

1. Disconnect temperature sensor from board and from outdoor coil.
2. Use an ohmmeter to measure the resistance of the sensor. Also use ohmmeter to check for short or open.
3. Check resistance reading to chart of resistance. Use sensor ambient temperature. (Tolerance of part is $\pm 10\%$.)
4. If sensor resistance reads very low, sensor is shorted and will not allow proper operation of the heat pump control.
5. If sensor is out of tolerance, shorted, open or reads very low ohms, it should be replaced.

TABLE 9
Temperature F vs. Resistance R of Temperature Sensor

F	R	F	R	F	R	F	R
-25.0	196871	13.0	56985	53.0	19374	89.0	7507
-24.0	190099	14.0	55284	52.0	18867	90.0	7334
-23.0	183585	15.0	53640	53.0	18375	91.0	7165
-22.0	177318	16.0	52051	54.0	17989	92.0	7000
-21.0	171289	17.0	50514	55.0	17434	93.0	6840
-20.0	165487	18.0	49028	56.0	16984	94.0	6683
-19.0	159904	19.0	47590	57.0	16547	95.0	6531
-18.0	154529	20.0	46200	58.0	16122	96.0	6383
-17.0	149355	21.0	44855	59.0	15710	97.0	6239
-16.0	144374	22.0	43554	60.0	15310	98.0	6098
-15.0	139576	23.0	42295	61.0	14921	99.0	5961
-14.0	134956	24.0	41077	62.0	14544	100.0	5827
-13.0	130506	25.0	39898	63.0	14177	101.0	5697
-12.0	126219	26.0	38757	64.0	13820	102.0	5570
-11.0	122089	27.0	37652	65.0	13474	103.0	5446
-10.0	118108	28.0	36583	66.0	13137	104.0	5326
-9.0	114272	29.0	35548	67.0	12810	105.0	5208
-8.0	110575	30.0	34545	68.0	12492	106.0	5094
-7.0	107010	31.0	33574	69.0	12183	107.0	4982
-6.0	103574	32.0	32634	70.0	11883	108.0	4873
-5.0	100260	33.0	31723	71.0	11591	109.0	4767
-4.0	97064	34.0	30840	72.0	11307	110.0	4663
-3.0	93981	35.0	29986	73.0	11031	111.0	4562
-2.0	91008	36.0	29157	74.0	10762	112.0	4464
-1.0	88139	37.0	28355	75.0	10501	113.0	4367
0.0	85371	38.0	27577	76.0	10247	114.0	4274
1.0	82699	39.0	26823	77.0	10000	115.0	4182
2.0	80121	40.0	26092	78.0	9760	116.0	4093
3.0	77632	41.0	25383	79.0	9526	117.0	4006
4.0	75230	42.0	24696	80.0	9299	118.0	3921
5.0	72910	43.0	24030	81.0	9077	119.0	3838
6.0	70670	44.0	23384	82.0	8862	120.0	3757
7.0	68507	45.0	22758	83.0	8653	121.0	3678
8.0	66418	46.0	22150	84.0	8449	122.0	3601
9.0	64399	47.0	21561	85.0	8250	123.0	3526
10.0	62449	48.0	20989	86.0	8057	124.0	3452
11.0	60565	49.0	20435	87.0	7869		
12.0	58745	50.0	19896	88.0	7686		

Troubleshooting ECM™ Indoor Blower Motors

CAUTION: Disconnect power from unit before removing or replacing connectors, or servicing motor. To avoid electric shock from the motor's capacitors, disconnect power and wait at least 5 minutes before opening motor.

Symptom	Cause/Procedure
Motor rocks slightly when starting	This is normal start-up for ECM
Motor won't start: No movement	Check blower turns by hand Check power at motor Check low voltage (24 Vac R to C) at motor Check low voltage connections (G, R, C) at motor Check for unseated pins in connectors on motor harness (see Table 10 on page 42) Test with a temporary jumper between R - G Check motor for tight shaft Perform motor/control replacement check Perform Moisture Check
Motor won't start: Motor rocks but won't start	Check for loose or compliant motor mount Make sure blower wheel is tight on shaft Perform motor/control replacement check
Motor oscillates up and down while being tested off of blower	It is normal for motor to oscillate with no load on shaft
Motor starts but runs erratically: Varies up or down or intermittent	Check line voltage for variation or "sag" Check low voltage connections (G, R, C) at motor, unseated pins in motor harness connectors Check out system controls, thermostat Perform Moisture Check
Motor starts but runs erratically: "Hunts" or "puffs"	Does removing panel or filter reduce "puffing"? - Reduce restriction
Motor starts but runs erratically: Blower won't shut off	Current leakage from controls into G, Y? - Check for Triac-switched thermostat or solid-state relay
Excessive noise	Determine if it's air noise, cabinet, duct or motor noise; interview customer, if necessary
Excessive noise: Air noise	High static creating high blower speed? - Is airflow set properly? - Does removing filter cause blower to slow down? Check filter - Use low-pressure drop filter - Check/correct duct restrictions
Excessive noise: Noisy blower or cabinet	Check for loose blower housing, panels, etc. High static creating high blower speed? - Check for air whistling through seams in ducts, cabinets or panels - Check for cabinet/duct deformation
Evidence of Moisture: Motor failure or malfunction has occurred and moisture is present	Replace motor and Perform Moisture Check
Evidence of Moisture: Evidence of moisture present inside air mover	Perform Moisture Check

Do's and Don't's	
Do	Don't
Check out motor, controls, wiring and connections thoroughly before replacing motor	Automatically assume motor is bad
Orient connectors down so water can't get in - Install "drip loops"	Locate connectors above 8 and 4 o'clock positions
Use authorized motor and model #s for replacement	Replace one motor or control model # with another (unless an authorized replacement)
Keep static pressure to a minimum: - Recommend high efficiency, low static filters - Recommend keeping filters clean - Design ductwork for minimum static, maximum comfort - Look for and recommend ductwork improvement, where necessary	Use high pressure drop filters—some have ½" H ₂ O drop! Use restricted returns
Size equipment wisely	Oversize system then compensate with low airflow
Check orientation before inserting motor connectors	Plug in power connector backwards Force plug

Moisture Check

- Connectors are oriented "down" (or as recommended by equipment manufacturer)
- Arrange harness with "drip loop" under motor
- Is condensate drain plugged?
- Check for low airflow (too much latent capacity)
- Check for undercharged condition
- Check and plug leaks in return ducts, cabinet

Comfort Check

- Check proper airflow settings
- Low static pressure for lowest noise
- Thermostat in bad location?

Replacing ECM Control Module

The following steps must be taken to replace the control module for the GE variable-speed indoor blower motor:

1. MUST have the correct replacement module. The controls are factory programmed for specific operating modes. Even though they look alike, different modules may have completely different functionality.
Using the wrong control module voids all product warranties and may produce unexpected results.
2. Begin by removing AC power from the unit being serviced. **Do not work on the motor with AC power applied.** To avoid electric shock from the motor's capacitors, disconnect power and wait at least 5 minutes before opening motor.
3. It is not necessary to remove the motor from the blower assembly, nor the blower assembly from the unit. Unplug the two cable connectors to the motor control assembly. There are latches on each connector. **Do not pull on the wires.** The plugs remove easily when properly released.
4. Locate the screws that retain to the motor control bracket to the sheet metal of the unit and remove them. Remove two (2) nuts that retain the control to the bracket and then remove two (2) nuts that retain sheet metal motor control end plate (see Figure 24).
5. Using thumb and forefinger to squeeze the latch tab and the opposite side of the connector plug and gently pulling the connector, disconnect the three (3) wires interior of the motor control. **Do not pull on the wires; grip the plug only.** See Figure 24.
6. The control module is now completely detached from the motor. Verify with a standard ohmmeter the motors winding resistance:
 - A. Measure that there is resistance between pins 1 to 2, 1 to 3 and 2 to 3. The readings should not be 0 ohms and all three measurements should be within $\pm 10\%$ of each other. Move to step B if the windings resistance are within range. **If any motor lead fails this test, the motor is defective and must be replaced.**
 - B. Test that each lead to the motor shell is $>100K$ ohms (see Figure 25). (Take measurement to unpainted motor end plate.) **If any motor lead fails this test, the motor is defective and must be replaced.**

NOTE: *Installing the new control module will cause it to fail also.*

7. Verify that the replacement control is correct for the application. Refer to the manufacturer's authorized replacement list. **Using the wrong control will result in improper or no blower operation.** Orient the control module so that the 3-wire motor plug can be inserted into the socket in the control. Carefully insert the plug and press it into the socket until it latches. **A slight click will be heard when properly inserted.**
8. Reverse Steps #5, 4 and 3 to reconnect the motor control to the motor wires, securing the motor control cover plate, mounting the control to the bracket and mounting the motor control bracket back into the unit. **Make sure the orientation selected for replacing the control ensures the control's cable connectors will be located downward in the application so that water cannot run down the cables and into the control. Do not overtighten the bolts.**
9. Plug the 16-pin control plug into the motor. The plug is keyed. Make sure the connector is properly seated and latched.
10. Plug the 5-pin power connector into the motor. Even though the plug is keyed, **observe the proper orientation. Do not force the connector.** It plugs in very easily when properly oriented. **Reversing this plug will cause immediate failure of the control module.**
11. Final installation check. Make sure the motor is installed as follows:
 - A. Motor connectors should be oriented between the 4 o'clock and 8 o'clock positions when the control is positioned in its final location and orientation.
 - B. Add a drip loop to the cables so that water cannot enter the motor by draining down the cables (see Figure 26).

The installation is now complete. Reapply AC power to the HVAC equipment and verify that the new motor control module is working properly. Follow the manufacturer's procedures for disposition of the old control module.

FIGURE 24
Control Disassembly

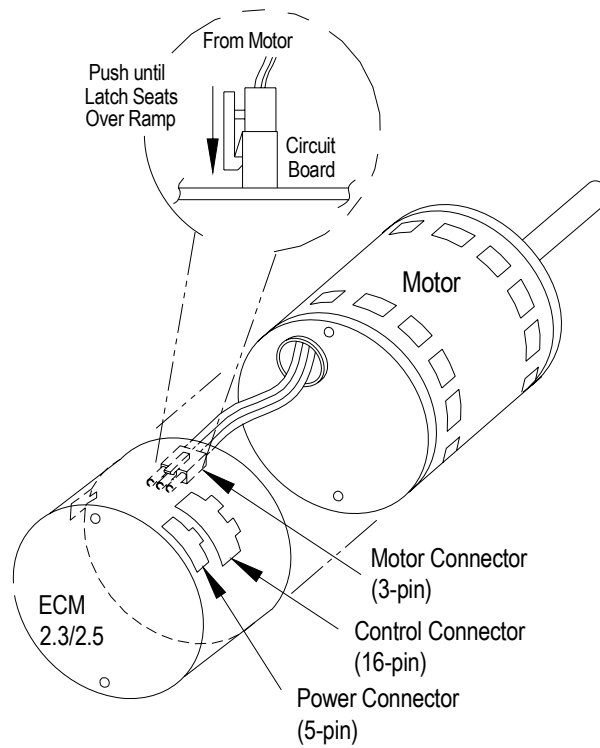

FIGURE 25
Winding Test

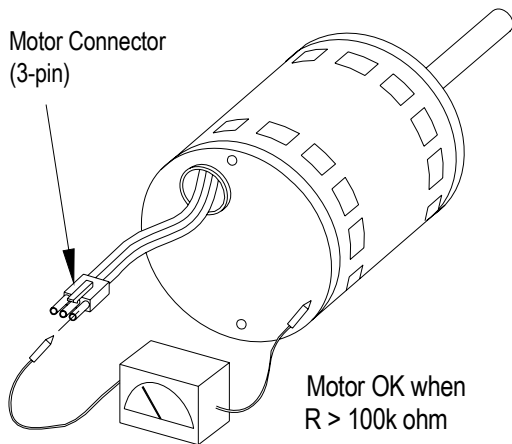

FIGURE 26
Drip Loop

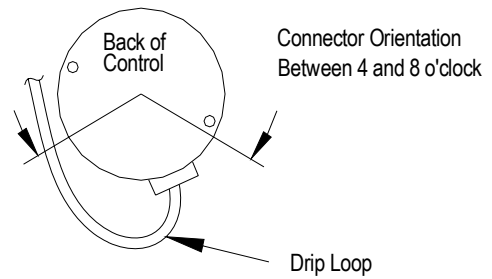
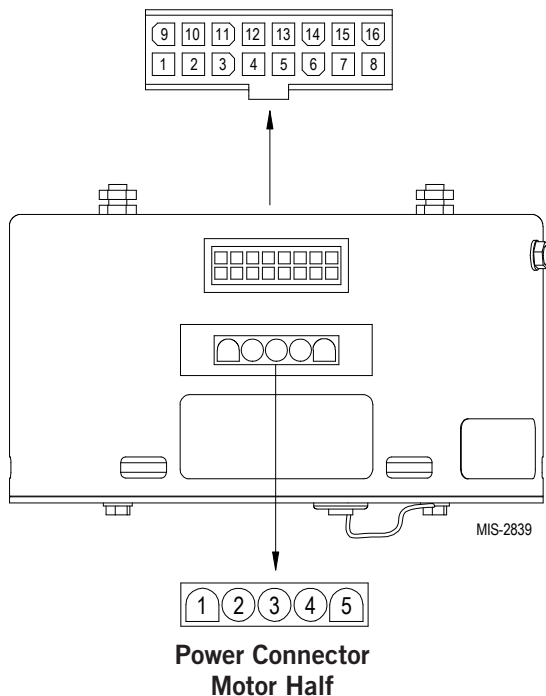

TABLE 10
Troubleshooting ECM™ Indoor Blower Motors

Mode of Operation	OFF	Continuous Blower (Ventilation Mode)	Full Load Cooling	Dehum. Mode (when equipped)	Full Load Heat Pump	Heat Pump Full Load w/ 1st Bank of Elec. Heat	Heat Pump Full Load w/ 1st & 2nd Bank of Elec. Heat	Emergency Heat Mode
Thermostat 24 VAC Input Signals	—	"G"	"G", "Y1", "Y2"	"D"	"G", "B", "Y1", "Y2"	"G", "Y1", "Y2", "B", "W1", "W2"	"G", "Y1", "Y2", "B", "W2", "W3"	"G", "W2", "W3"
Pin #1	24 VAC "C" (Common) Signal, Always Energized							
Pin #2						X		
Pin #3	24 VAC "C" (Common) Signal, Always Energized							
Pin #4	Not Used							
Pin #5	Not Used							
Pin #6			X	X	X	X	X	
Pin #7	Not Used							
Pin #8	Not Used							
Pin #9					X	X	X	
Pin #10		X	X	X	X	X	X	X
Pin #11	Not Used							
Pin #12	24 VAC Hot "R" Signal, Always Energized							
Pin #13						X	X	X
Pin #14			X		X	X	X	
Pin #15		X	X	X	X	X	X	X
Pin #16	Not Used							

FIGURE 27 – Control Connector Motor Half



POWER CONNECTOR	
PWB HEADER	AMP 1-350945-0
PIN	Description
1	Jumper Pin 1 to Pin 2 for 120VAC Line Input Only **
2	
3	Chassis Ground
4	AC Line
5	AC Line

* Suggested mating connector
Housing – AMP 350809-1
Contact – AMP 350537-1

** **WARNING: Applying 240VAC line input with PIN 1 to PIN 2 jumper in place will permanently damage unit!**

Refrigerant Leak Detection System (RDS)

This unit is equipped with a refrigerant leak detection system (RDS). This system monitors the air in the indoor section of the unit for refrigerant leaks. In the event of a leak, the RDS will enter mitigation mode, which prohibits function of the compressor and electric heaters (if applicable) and turns on the indoor blower in order to prevent the refrigerant from concentrating within the unit. The RDS is made up of three major components: Refrigerant sensor, RDS harness and DPDT relay (see Figure 28).

Why RDS?

R-454B refrigerant carries an "A2L" safety classification, meaning it is mildly flammable in certain concentrations. The purpose of the RDS is to prevent refrigerant from reaching potentially dangerous concentrations within the indoor section of the unit in the event of a refrigerant leak.

Sequence of Operations

The refrigerant sensor has four operating modes: Power up and self test, normal, alarm state and sensor fault. During all modes of operation the sensor will continue to perform runtime diagnostics.

FIGURE 28
Refrigerant Leak Detection System

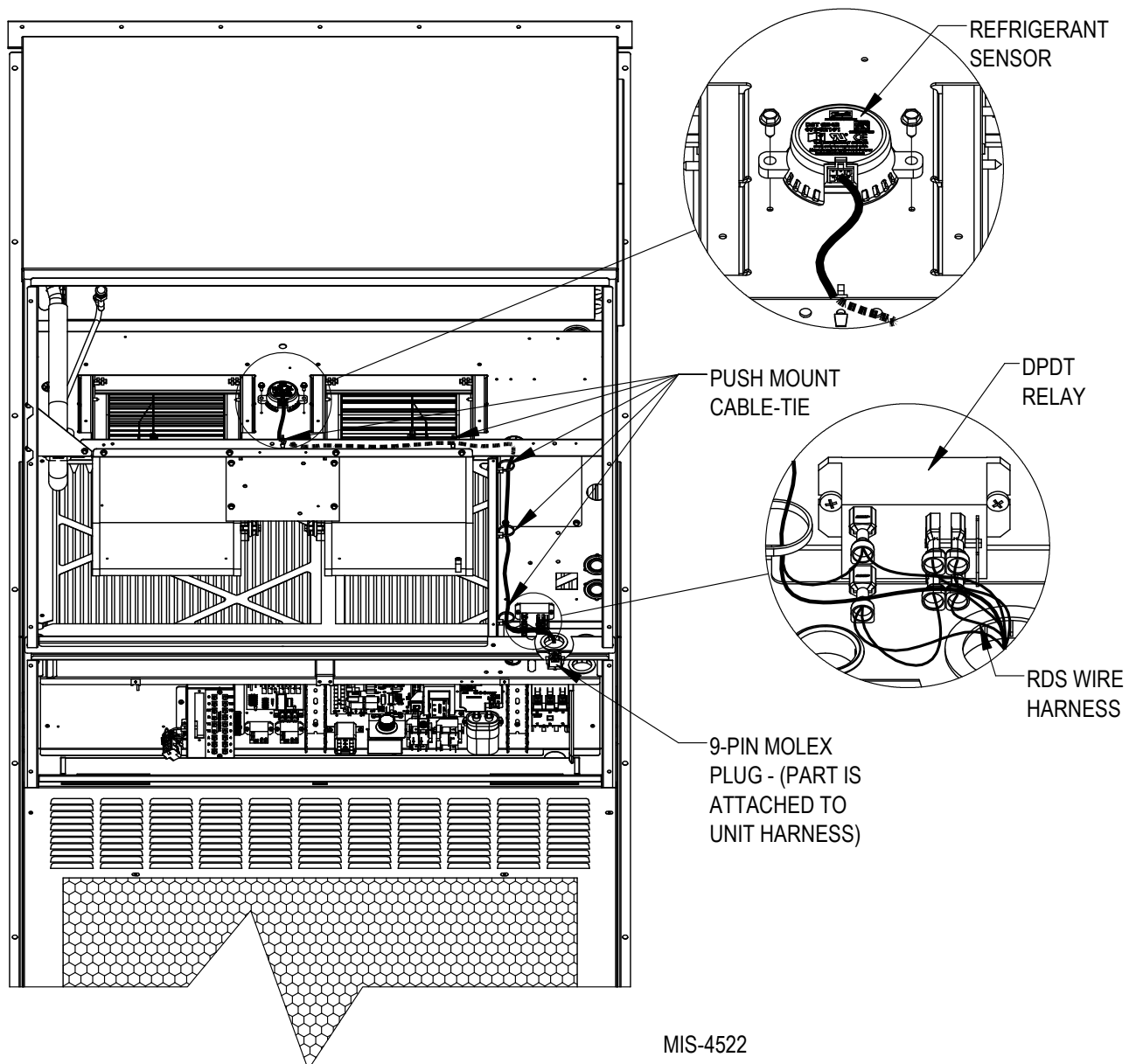

MIS-4522

Power Up and Self Test

When the unit receives power, the refrigerant sensor executes a series of self test diagnostics. This validates the integrity of the sensor's memory, embedded program, and power supply. This power up sequence only takes a few seconds.

Normal Operation

Once the refrigerant sensor's power up sequence is complete, the RDS begins normal operation. In this mode the refrigerant sensor is active and the air conditioner functions normally.

Alarm State

The refrigerant sensor has a factory-set alarm threshold limit value. When the sensor registers refrigerant at a concentration above this threshold, the sensor enters alarm state. In alarm state the internal relay within the refrigerant sensor is de-energized, which puts the RDS into mitigation mode.

Sensor Fault Mode

The refrigerant sensor performs continuous diagnostics on the sensor integrity (shorts, opens, out of range, communication errors) as well as the integrity of the on-board memory, programming, oscillator and voltage levels. If any of these diagnostics fail or the sensor becomes disconnected, the internal relay within the refrigerant sensor is de-energized, which puts the RDS into mitigation mode.

Mitigation Mode

When the RDS enters mitigation mode, it initiates the following:

- The "G" terminal is energized on the low voltage terminal strip. This activates the indoor blower.
- The signal from "CC" on the defrost control board to the compressor contactor is interrupted. This stops compressor operation and prevents it from starting in the event of a call from the thermostat.
- The 24V common connection to all electric heat contactors (if applicable) is broken. This stops electric heat operation and prevents it from starting in the event of a heating call.
- The "L" terminal on the low voltage terminal strip is energized. This output may be used to trigger an external alarm or notify a building management system or thermostat that a leak has occurred.

Alarm Reset





The refrigerant sensor will stay in alarm mode as long as the refrigerant concentration remains above the alarm threshold limit value. For the alarm to be reset, the sensor reading must be a minimum of 2.5% below the alarm threshold for a period of 5 minutes. The relay is then re-energized, and the unit returns to normal operation.

RDS Diagnosis

The refrigerant sensor of the RDS features a status LED. When the sensor is powered up, an LED will indicate sensor status. The sensor LED will back-light the sensor and create a visible reflection on the blower partition. Status LED blink codes shown in Figure 29.

NOTE: *If the sensor status LED is not lit, the sensor is either not receiving power or may be faulty or damaged. Check harness connections and test internal relay. Refer to A2L Safety Manual 2100-810 for additional diagnostic information.*

FIGURE 29
Sensor Status LED Blink Code

	Solid Green: Sensor Power Up and Self Test
	Blinking Green: Normal Operation
	Solid Red: Alarm State – Gas Detection
	Blinking Red: Sensor Fault



Sensor End-of-Life

The refrigerant sensor has a rated life expectancy of 15+ years. This is not a set time length, but it is the expected time that the sensor should last without failing its internal checks. In the event that the sensor would reach its end-of-life, it will enter Sensor Failure Mode and the sensor will need to be replaced. **The sensor must be replaced with a Bard-approved refrigerant sensor.** See unit replacement parts manual for the correct replacement sensor information.

FIGURE 30
Refrigerant Leak Detection System (RDS) Troubleshooting

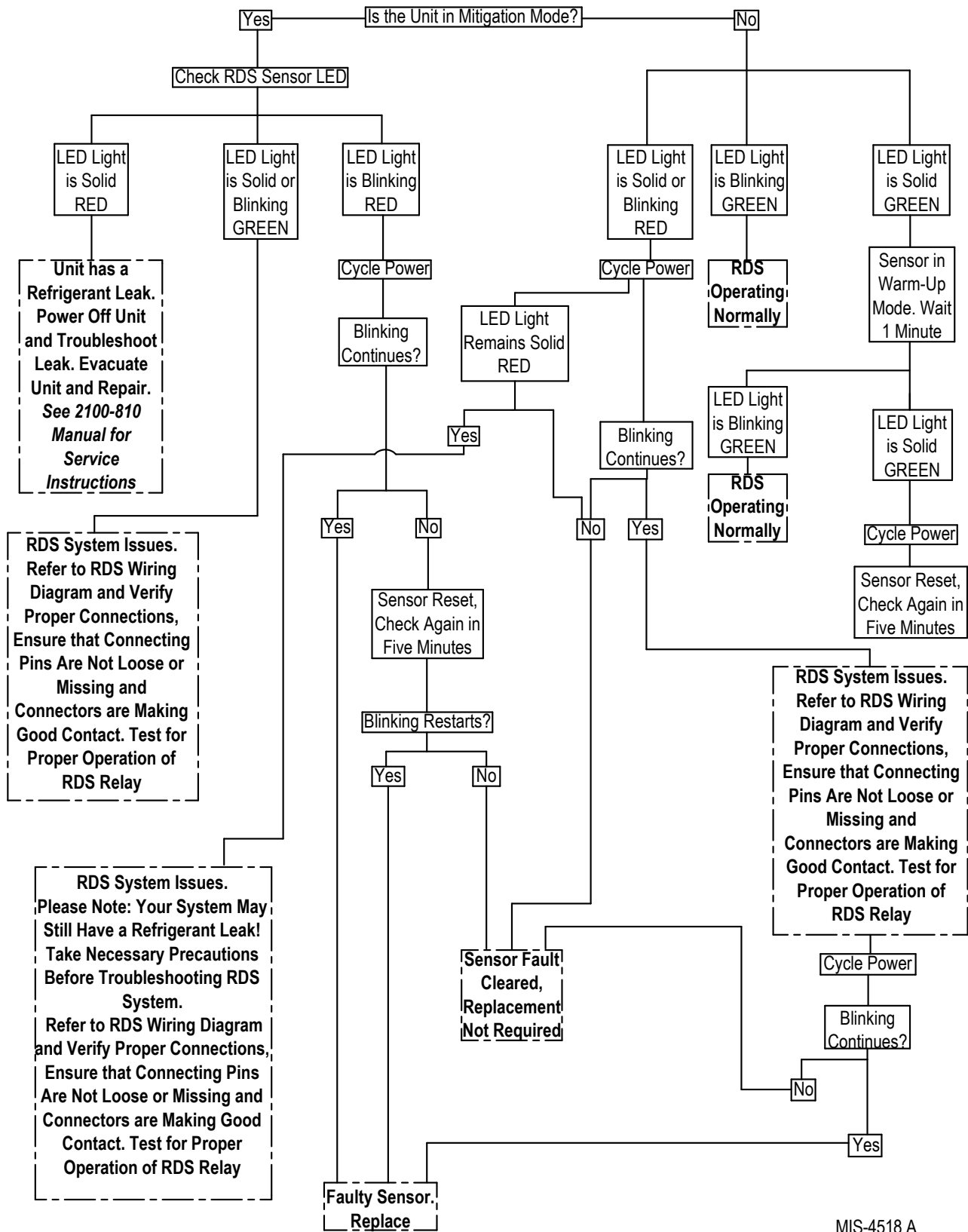

MIS-4518 A

Fan Blade Setting Dimensions

Shown in Figure 32 is the correct fan blade setting for proper air delivery across the outdoor coil. Refer to Table 11 for unit specific dimension.

Any service work requiring removal or adjustment in the fan and/or motor area will require that the dimensions below be checked and blade adjusted in or out on the motor shaft accordingly.

FIGURE 32
Fan Blade Setting

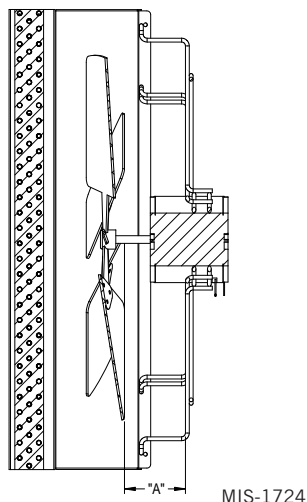

TABLE 11
Fan Blade Dimensions

Model	Dimension A
C36HF C42HF C48HF C60HF	1.5"

NOTE: Dimension "A" is for both draw thru and blow thru configurations.

R-454B Refrigerant Charge

This unit was charged at the factory with the quantity of refrigerant listed on the serial plate. AHRI capacity and efficiency ratings were determined by testing with this refrigerant charge quantity.

The pressure tables on pages 48, 49 and 50 show nominal pressures for the units. Since many installation specific situations can affect the pressure readings, this information should only be used by certified technicians as a guide for evaluating proper system performance. They shall not be used to adjust charge. If charge is in doubt, reclaim, evacuate and recharge the unit to the serial plate charge.

Condenser Coil Cleaning Access

1. Disconnect all power to the unit.
2. On the side opposite of the compressor, remove the screws holding grille in place (see Figure 33).
3. Remove screws connecting fan shroud access door to fan shroud.
4. Clean condenser coil as thoroughly as needed.
5. Reverse steps to re-install.

Important Cleaning Note

For improved start-up performance, wash the indoor coil with dishwasher detergent.

IMPORTANT: Please be aware of the cabinet style of installed unit. The units are manufactured as blow thru or draw thru. This will affect which side of coil will need most attention when cleaning.

FIGURE 33
Condenser Coil Access Removal

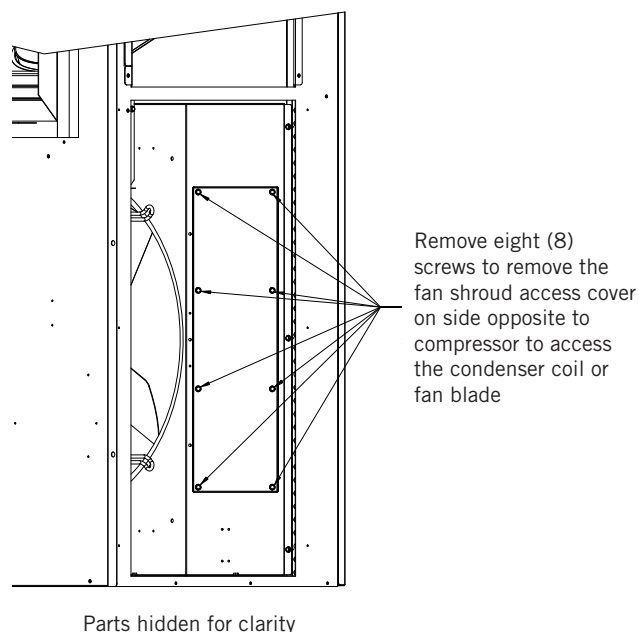

MIS-4427

TABLE 12A
Cooling Pressures – Rated Airflow

Air Temperature Entering Outdoor Coil °F

Model	Return Air Temp (DB/WB)	Pressure	75	80	85	90	95	100	105	110	115	120	125
C36HF	75/62	Suction Pressure	122	123	125	126	127	128	130	131	132	133	134
		Head Pressure	284	305	327	350	374	399	425	451	479	508	538
	80/67	Suction Pressure	130	132	133	135	136	137	139	140	141	142	143
		Head Pressure	292	313	335	359	383	409	435	463	492	521	552
	85/72	Suction Pressure	135	136	138	139	141	142	144	145	146	147	148
		Head Pressure	302	324	347	371	397	423	451	479	509	539	571
C42HF	75/62	Suction Pressure	122	123	124	125	126	127	128	129	131	132	133
		Head Pressure	288	311	334	359	384	410	436	464	492	521	550
	80/67	Suction Pressure	131	132	133	134	135	136	137	138	140	141	143
		Head Pressure	295	319	343	368	394	420	448	476	504	534	564
	85/72	Suction Pressure	135	136	137	138	139	141	142	143	145	146	148
		Head Pressure	305	330	355	381	408	435	463	492	522	553	584
C48HF	75/62	Suction Pressure	118	119	120	121	123	124	125	126	128	129	---*
		Head Pressure	289	311	335	359	384	410	436	464	492	521	
	80/67	Suction Pressure	126	127	129	130	131	132	134	135	136	138	
		Head Pressure	296	319	343	368	394	420	448	476	504	534	
	85/72	Suction Pressure	130	132	133	134	136	137	138	140	141	143	
		Head Pressure	306	330	355	381	408	435	463	492	522	553	
C60HF	75/62	Suction Pressure	117	118	118	119	119	120	121	123	124	126	---*
		Head Pressure	287	307	329	351	375	399	425	451	478	507	
	80/67	Suction Pressure	126	126	126	127	128	129	130	131	133	135	
		Head Pressure	294	315	337	360	384	409	436	463	491	520	
	85/72	Suction Pressure	130	130	131	131	132	133	134	136	138	140	
		Head Pressure	304	326	349	373	398	424	451	479	508	538	

Low side pressure ± 4 PSIG
High side pressure ± 10 PSIG

Tables are based upon rated CFM (airflow) across the evaporator coil. If there is any doubt as to correct operating charge being in the system, the charge should be removed and system evacuated and recharged to serial plate charge weight.

NOTE: Pressure table based on high speed condenser fan operation. If condensing pressures appear elevated check condenser fan wiring. See **Condenser Fan Operation** on page 33.

* Operating at these conditions would be outside the compressor operating envelope and is not recommended.

TABLE 12B
Cooling Pressures – Part Load

Air Temperature Entering Outdoor Coil °F

Model	Return Air Temp (DB/WB)	Pressure	75	80	85	90	95	100	105	110	115	120	125
C36HF	75/62	Suction Pressure	127	128	129	130	130	132	133	134	136	137	139
		Head Pressure	220	258	278	298	320	342	365	389	414	439	465
	80/67	Suction Pressure	135	137	138	139	140	141	142	143	145	147	148
		Head Pressure	226	264	285	306	328	351	375	399	424	450	477
	85/72	Suction Pressure	140	142	142	143	144	146	147	148	150	152	154
		Head Pressure	234	274	295	317	340	363	388	413	439	466	494
C42HF	75/62	Suction Pressure	123	125	126	128	129	130	132	133	135	136	138
		Head Pressure	224	261	281	302	323	346	369	393	418	443	470
	80/67	Suction Pressure	132	134	135	136	138	139	141	142	144	146	148
		Head Pressure	229	268	288	310	332	355	378	403	428	455	482
	85/72	Suction Pressure	137	139	140	141	143	144	146	147	149	151	153
		Head Pressure	237	277	298	320	343	367	392	417	443	471	499
C48HF	75/62	Suction Pressure	120	121	122	122	123	124	126	127	129	150	---*
		Head Pressure	225	262	281	302	324	346	370	395	420	459	
	80/67	Suction Pressure	128	129	130	131	132	133	134	136	137	160	
		Head Pressure	231	268	289	310	332	355	380	405	431	471	
	85/72	Suction Pressure	133	134	134	135	136	138	139	140	142	166	
		Head Pressure	239	278	299	321	344	368	393	419	446	487	
C60HF	75/62	Suction Pressure	124	122	121	121	121	122	122	123	125	127	---*
		Head Pressure	239	273	292	312	333	355	379	404	430	457	
	80/67	Suction Pressure	132	130	129	129	129	130	131	132	134	136	
		Head Pressure	245	280	299	320	341	364	389	414	441	469	
	85/72	Suction Pressure	137	134	134	134	134	134	135	137	138	140	
		Head Pressure	254	290	310	331	353	377	402	429	456	485	

Low side pressure ± 4 PSIG
High side pressure ± 10 PSIG

Tables are based upon rated CFM (airflow) across the evaporator coil. If there is any doubt as to correct operating charge being in the system, the charge should be removed and system evacuated and recharged to serial plate charge weight.

NOTE: Pressure table based on high speed condenser fan operation. If condensing pressures appear elevated check condenser fan wiring. See **Condenser Fan Operation** on page 33.

* Operating at these conditions would be outside the compressor operating envelope and is not recommended.

TABLE 13A
Heating Pressures – Rated Airflow

Model	Return Air Temp (DB)	Pressure	Air Temperature Entering Outdoor Coil												
			0°F	5°F	10°F	15°F	20°F	25°F	30°F	35°F	40°F	45°F	50°F	55°F	60°F
			-17.7°C	-15°C	-12.2°C	-9.4°C	-6.6°C	-3.8°C	-1.1°C	1.6°C	4.4°C	7.2°C	10°C	12.7°C	15.5°C
C36HF	70	Suction Pressure	36	41	47	53	59	66	72	80	87	95	102	111	119
		Head Pressure	257	265	273	281	289	298	307	316	325	335	345	355	365
C42HF	70	Suction Pressure	23	30	37	44	52	59	67	74	82	90	98	106	115
		Head Pressure	230	243	255	268	280	292	303	315	326	338	348	359	370
C48HF	70	Suction Pressure	30	36	43	49	56	63	70	78	85	93	101	109	118
		Head Pressure	265	275	285	296	306	317	327	338	349	360	371	383	394
C60HF	70	Suction Pressure	35	40	46	51	57	64	70	77	84	92	99	107	116
		Head Pressure	261	271	282	293	304	315	326	337	349	361	372	384	396

TABLE 13B
Heating Pressures – Part Load

Model	Return Air Temp (DB)	Pressure	Air Temperature Entering Outdoor Coil												
			0°F	5°F	10°F	15°F	20°F	25°F	30°F	35°F	40°F	45°F	50°F	55°F	60°F
			-17.7°C	-15°C	-12.2°C	-9.4°C	-6.6°C	-3.8°C	-1.1°C	1.6°C	4.4°C	7.2°C	10°C	12.7°C	15.5°C
C36HF	70	Suction Pressure	42	47	52	58	64	70	77	85	93	102	111	121	131
		Head Pressure	238	245	253	261	269	278	286	295	304	313	322	332	342
C42HF	70	Suction Pressure	37	42	48	54	61	68	75	83	91	99	108	117	126
		Head Pressure	239	245	252	259	267	276	284	294	304	314	325	337	349
C48HF	70	Suction Pressure	35	40	46	53	60	67	74	82	91	99	108	118	128
		Head Pressure	254	262	270	278	287	296	305	314	324	334	345	356	367
C60HF	70	Suction Pressure	35	40	46	52	58	65	73	80	88	97	105	114	124
		Head Pressure	261	269	276	284	293	302	311	321	332	342	354	365	377

TABLE 14
Electrical Specifications – CHF Series**

Model	Rated Volts & Phase	No. Field Power Circuits	Single Circuit		Multiple Circuit			
			① Minimum Circuit Ampacity	② Maximum External Fuse or Circuit Breaker	① Minimum Circuit Ampacity		② Maximum External Fuse or Circuit Breaker	
					Circuit A	Circuit B	Circuit A	Circuit B
C36HF-A0Z A05 A10 ④ A15	230/208-60-1	1 1 1 or 2 1 or 2	25 51 77 84	30 60 80 90	25 32	52 52	30 35	60 60
C36HF-B0Z B05 B09 ③ B15	230/208-60-3	1 1 1 1	20 35 47 52	25 35 50 60				
C36HF-C0Z, C0C C05 C09 ③ C15	460-60-3	1 1 1 1	10 17 23 26	15 20 25 30				
C42HF-A0Z A05 A10 ④ A15	230/208-60-1	1 1 1 or 2 1 or 2	30 56 82 85	35 60 90 90	30 33	52 52	35 35	60 60
C42HF-B0Z B05 B09 ③ B15	230/208-60-3	1 1 1 1	22 37 49 52	25 40 50 60				
C42HF-C0Z, C0C C05 C09 ③ C15	460-60-3	1 1 1 1	12 20 26 26	15 20 30 30				
C48HF-A0Z A05 A10 ④ A15	230/208-60-1	1 1 1 or 2 1 or 2	31 57 83 85	35 60 90 90	31 33	52 52	35 35	60 60
C48HF-B0Z B05 B09 ③ B15	230/208-60-3	1 1 1 1	23 38 50 52	30 40 50 60				
C48HF-C0Z, C0C C05 C09 ③ C15	460-60-3	1 1 1 1	13 20 26 26	15 20 30 30				
C60HF-A0Z A05 A10 ④ A15 ④ A20	230/208-60-1	1 1 or 2 1 or 2 1 or 2 1 or 2	42 68 94 94 112	50 70 100 100 110	42 42 42 60	26 52 52 52	50 50 50 60	30 60 60 60 60
C60HF-B0Z B05 B09 ③ B15	230/208-60-3	1 1 1 1	28 43 55 55	35 45 60 60				
C60HF-C0Z, C0C C05 C09 ③ C15	460-60-3	1 1 1 1	14 22 28 28	20 25 30 30				

① These “Minimum Circuit Ampacity” values are to be used for sizing the field power conductors. Refer to the National Electrical code (latest version), Article 310 for power conductor sizing. **CAUTION:** When more than one field power circuit is run through one conduit, the conductors must be derated. Pay special attention to note 8 of Table 310 regarding Ampacity Adjustment Factors when more than three (3) current carrying conductors are in a raceway.

② Maximum size of the time delay fuse or circuit breaker for protection of field wiring conductors.

③ Three phase maximum kW that can operate with the heat pump on is 9 kW. Full heat available during emergency heat mode.

④ Single phase maximum kW that can operate with the heat pump on is 10 kW. Full heat available during emergency heat mode.

NOTE: The Maximum Overcurrent Protection (MOCP) value listed is the maximum value as per UL 60335 calculations for MOCP (branch-circuit conductor sizes in this chart are based on this MOCP). The actual factory-installed overcurrent protective device (circuit breaker) in this model may be lower than the maximum UL 60335 allowable MOCP value, but still above the UL 60335 minimum calculated value or Minimum Circuit Ampacity (MCA) listed.

Unit Airflow

These units are equipped with a variable speed (ECM) indoor motor that automatically adjusts itself to maintain approximately the same rate of indoor airflow in both heating and cooling, dry and wet coil conditions and at both 230/208 or 460 volts.

An additional feature of the system is the possibility to reduce the airflow by 10%. This can be accomplished by disconnection of blower motor low voltage wire coming from PIN 10 and connected to the "R" terminal of the defrost board. If this wire is disconnected, use electrical tape to cover end of connector to prevent short-circuiting. The 10% reduction will only be adjusted when unit is running in cooling mode. In heating mode the blower will remain at rated airflow.

Dirty Filter Switch

1. Disconnect all power to the unit. Remove control panel outer cover and upper front panel.
2. The dirty filter switch is located on top of the filter partition between the blower wheels (see Figure 34). The dirty filter indicator light and reset switch is located on the right side of the filter access opening above the control panel. Remove the cover on the dirty filter switch and ensure the knob is set at 0.4" W.C. (see Figure 35). This is only a recommended starting point prior to making switch adjustments. Switch setting is highly dependent on filter type used, blower speed, unit ducting and other unit installation characteristics. See **Dirty Filter Switch Adjustment** on the following page for instructions on how to make proper switch adjustments.
3. Re-install upper front panel.

FIGURE 34
Dirty Filter Switch and Dirty Filter Indicator Light/Reset Switch

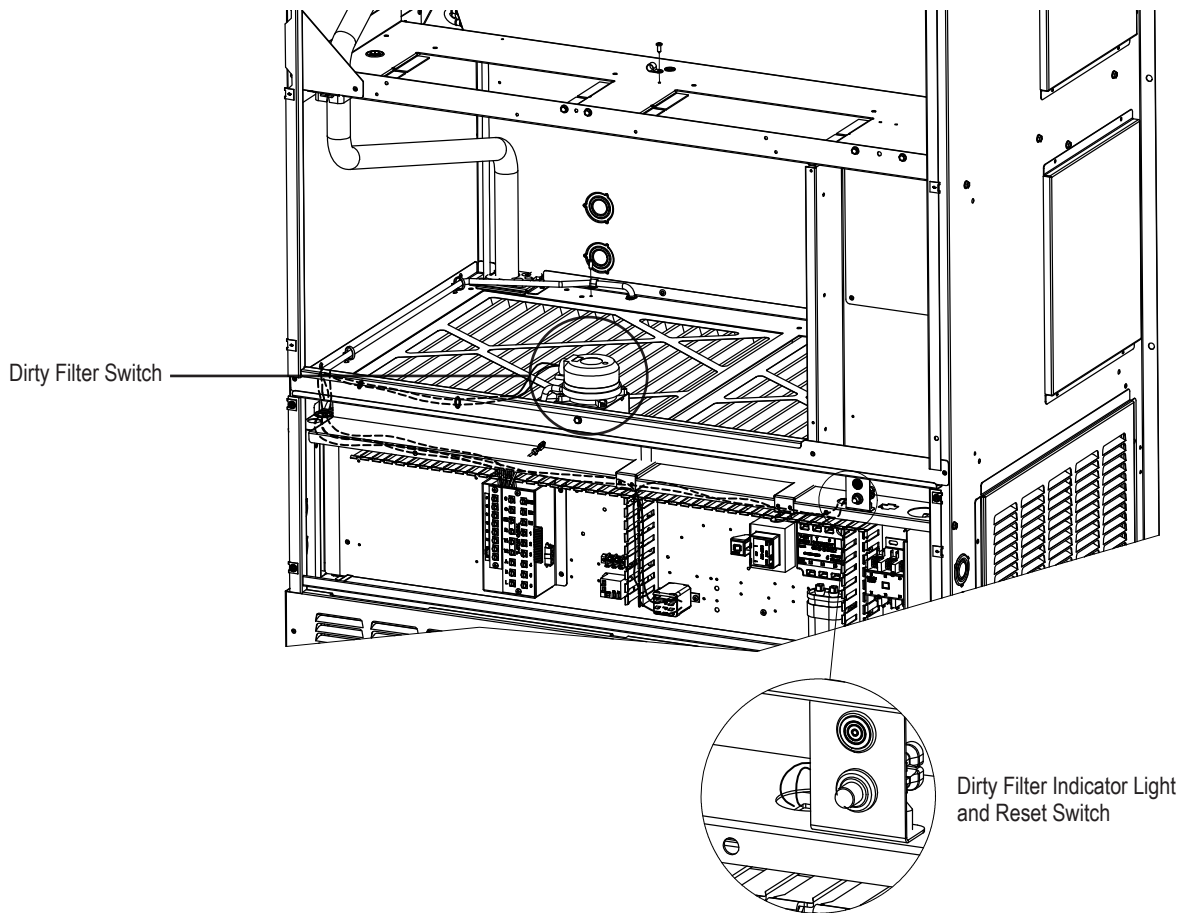

Dirty Filter Switch Adjustment

1. Apply power to the unit.
2. Turn the unit indoor blower on (energize R-G on low voltage terminal board).
3. With air filters installed and switch initially set at 0.4" W.C. (see Step 2 under **Dirty Filter Switch**), begin restricting the air filter of the unit using a piece of cardboard under the filters until the switch trips and the light comes on. If the filter is restricted by 75% (or desired restriction amount), skip to Step 6.
4. If switch setting adjustment is required, disconnect power to the unit. Remove the upper front panel and the cover on the airflow switch so that adjustment can be made. If the switch tripped before 75% restriction was reached, turn the knob slightly clockwise. If the switch tripped after 75%, turn the knob counter-clockwise (see Figure 35).
5. Replace the upper front panel and repeat Steps 1-3. Continue to make adjustments described in Step 4 until the desired restriction is obtained.
6. Remove the restriction and reset the filter switch. Replace the switch cover once adjustment is complete.
7. Install the outer control panel cover. This completes the adjustment.

FIGURE 35
Adjusting Dirty Filter Switch

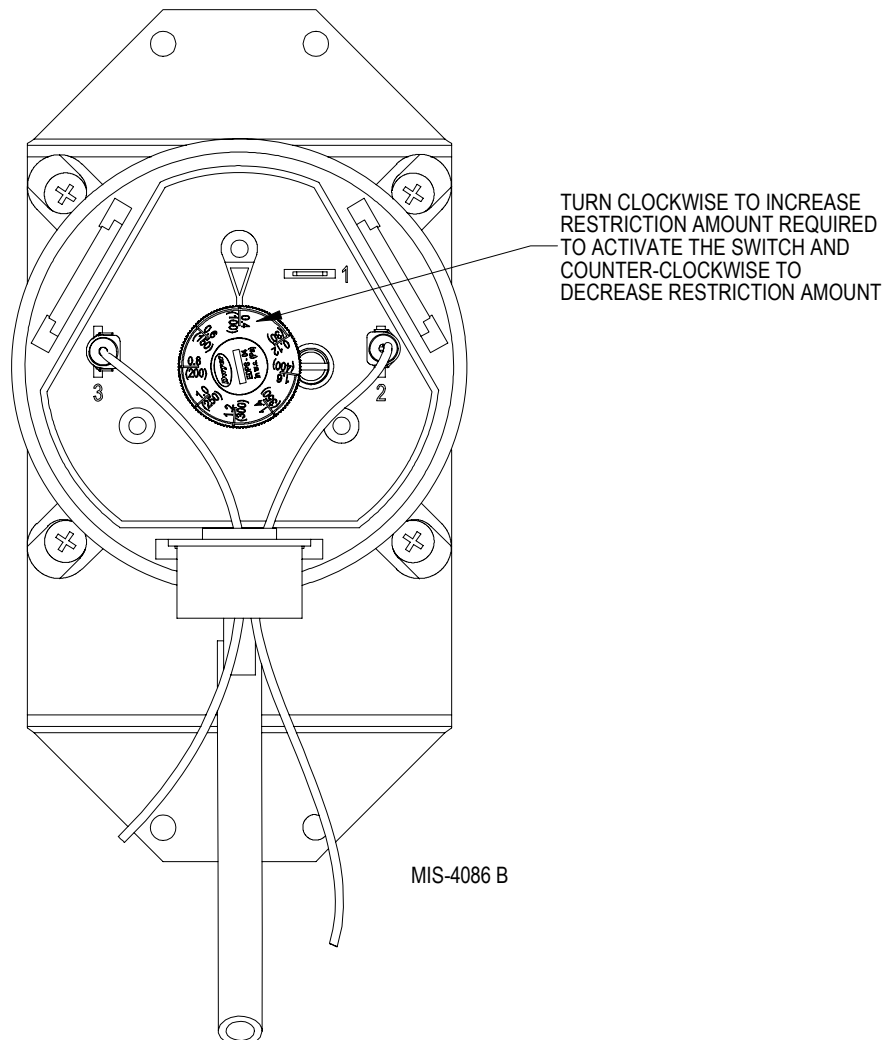

TABLE 15
Indoor Airflow Status and Unit Performance

Model	Rated ESP	Maximum ESP ①	Blower Only ②③	Cooling & Heating 1st Stage (CFM) ④	Cooling & Heating 2nd Stage (CFM) ④	Electric Heat ④
C36HF	0.15	0.50	800	800	1100	1100
C42HF	0.15	0.50	800	900	1250	1250
C48HF	0.20	0.50	850	1050	1450	1450
C60HF	0.20	0.50	850	1150	1650	1650

NOTE: These units are equipped with a variable speed (ECM) indoor motor that automatically adjusts itself to maintain approximately the same rate of indoor airflow in both heating and cooling, dry and wet coil conditions and at both 230/208 or 460 volts.

- ① Maximum ESP (inches WC) shown is with 2" thick disposable filter.
- ② Blower-only CFM is the total air being circulated during continuous fan mode. Airflow remains constant.
- ③ Blower-only CFM reduces during continuous fan mode. Requires wiring modification; consult installation instructions and wiring diagram.
- ④ CFM output on cooling or electric heat.

TABLE 16
Electric Heat

Electric Heat Nomenclature	Nominal kW	Total kW and BTUH @ Field-Supplied Voltage										
		@ 230V ①				@ 208V ①				@ 460V		
		kW	1-PH Amps	3-PH Amps	BTUH	kW	1-PH Amps	3-PH Amps	BTUH	kW	3-PH Amps	BTUH
05	5.0	4.6	20.0	11.5	15,700	3.8	18.0	10.4	12,800	4.6	5.8	15,700
09	9.0	8.3		20.8	28,300	6.8		18.7	23,000	8.3	10.4	28,300
10	10.0	9.2	40.0		31,400	7.5	36.1		25,600			
15	15.0	13.8	60.0	34.6	47,100	11.3	54.1	31.2	38,400	13.8	17.3	47,100
20	20.0	18.4	80.0		62,800	15.0	72.1		51,200			

① Listed electric heaters are available for 230/208V units only.

TABLE 17
Vent and Control Options

Part Number	Description	230V Units	460V Units
CMC-32	Start Kit (230V 1-Phase)	X	
CMC-33	Dirty Filter Switch Kit	X	X
CMC-35	Alarm Relay	X	X
CMC-38	Crankcase Heater – 230V	X	
CMC-39	Crankcase Heater – 460V		X
CMH-40	Low Ambient Control – On/Off (LAC)	X	X
CMH-36	Outdoor Thermostat (ODT)	X	X
CMH-41	Low Ambient Control and Outdoor Thermostat – Heat Pump (LAC & ODT)	X	X
BOPLATE-5	Blank-Off Plate	X	X
FAD-NE5	Fresh Air Damper – No Exhaust	X	X
FAD-BE5	Fresh Air Damper – Barometric Exhaust	X	X
CRV-F5	Commercial Ventilator – On/Off, Spring Return	X	X
CRV-V5A	Commercial Ventilator – 0-10V, Spring Return	X	X
ECON-NC5A	Economizer – Bldg. Equipment, 0-10V, No Controls	X	X
ECON-WD5A	Economizer – Bldg. Equipment, Enthalpy	X	X
ECON-DB5A	Economizer – Bldg. Equipment, Temperature	X	X
ERV-FA5*	Energy Recovery Ventilator – 230V	X	X

* For unit rated 460V, the vent option is connected to a step-down transformer to accommodate the 230V rating of the vent package.

NOTE: See ventilation manual for further details about ventilation options.

TABLE 18
Optional Accessories

		C36HF-A	C36HF-B	C36HF-C	C36HFDA	C36HFDB	C36HFDC	C42HF-A	C42HF-B	C42HF-C	C42HFDA	C42HFDB	C42HFDC	C48HF-A	C48HF-B	C48HF-C	C48HFDA	C48HFDB	C48HFDC	C60HF-A	C60HF-B	C60HF-C	C60HFDA	C60HFDB	C60HFDC		
Heater Kits	EHCH036A-A10	X			X																						
	EHCH036A-A15	X			X			X						X													
	EHCH036A-B05		X			X																					
	EHCH036B-B09		X			X		X				X			X			X									
	EHCH036A-C05			X			X		X				X														
	EHCH036A-C09			X			X		X				X														
	EHCH036A-C15			X			X		X				X														
	EHCH042A-A05	X			X			X																			
	EHCH042A-A10							X						X													
	EHWA042A-B05								X				X			X			X								
	EHCH042A-B15		X			X			X				X														
	EHCH048A-A05											X			X				X								
	EHCH048A-A10											X							X								
	EHCH048A-A15											X							X								
	EHCH048A-B05																					X			X		
	EHCH048A-B09																										
	EHCH048A-B15															X			X								
	EHCH048A-C05																X			X							
	EHCH048A-C09																X			X							
	EHCH048A-C15																X			X							
	EHCH060B-A05																				X			X			
	EHCH060B-A10																				X			X			
	EHCH060B-A15																				X			X			
	EHCH060A-A20																				X			X			
	EHCH060A-B09																					X			X		
	EHCH060A-B15																					X			X		
	EHCH060A-C05																						X			X	
	EHCH060A-C09																						X			X	
EHCH060A-C15																						X			X		
Circuit Breaker Kits (WMCBC)	WMCBC-04A	X			X																						
	WMCBC-03B		X			X		X																			
	WMCBC-06C			X			X		X				X			X			X			X			X		
	WMCBC-05A						X							X													
	WMCBC-04B											X			X				X								
	WMCBC-06A										X							X									
	WMCBC-08A																				X			X			
	WMCBC-05B																					X			X		

GRAPH 1
CH FAD-NE5 Without Exhaust Ventilation Delivery

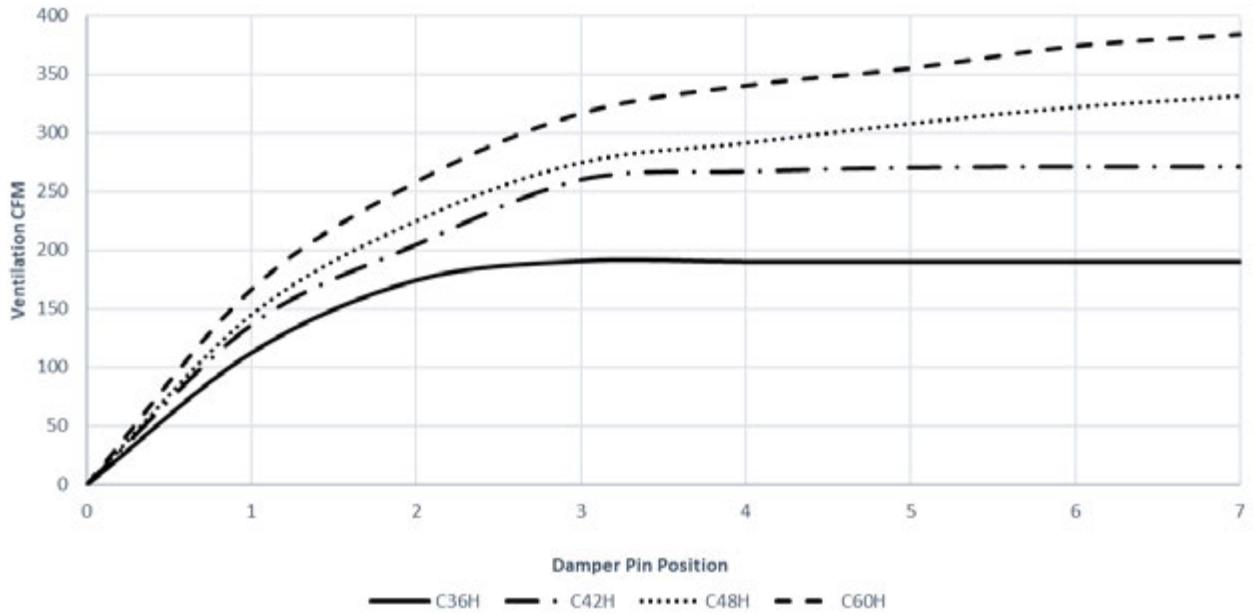

GRAPH 2
CH FAD-BE5 With Exhaust Ventilation Delivery

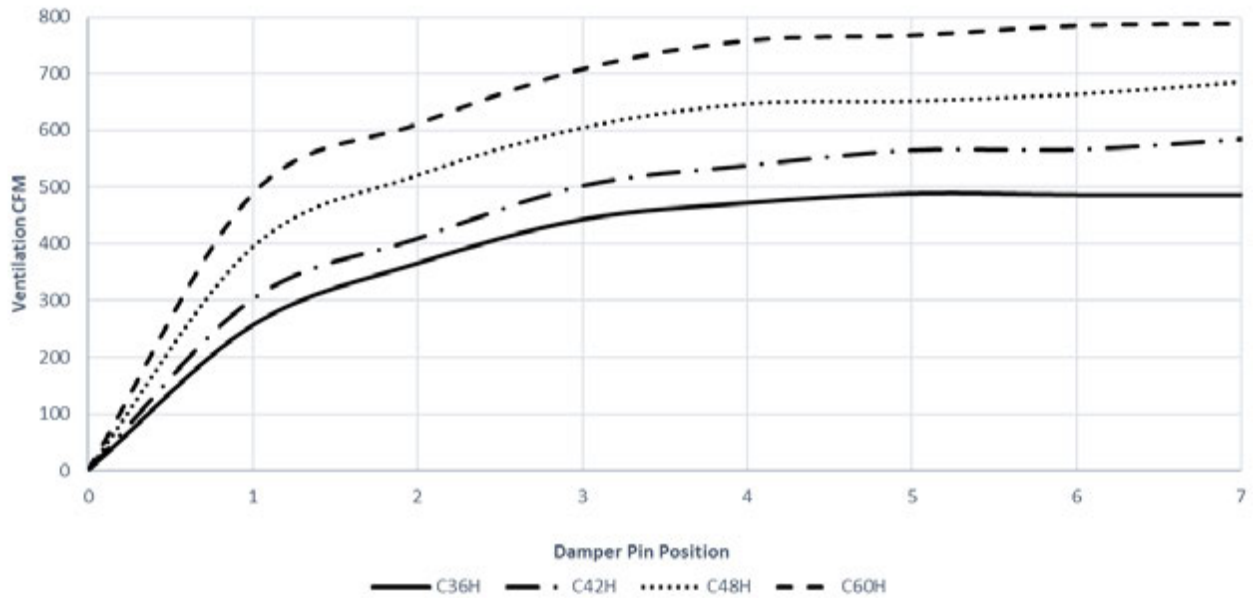

GRAPH 3
C36H & C42H CRV-FS Ventilation Delivery

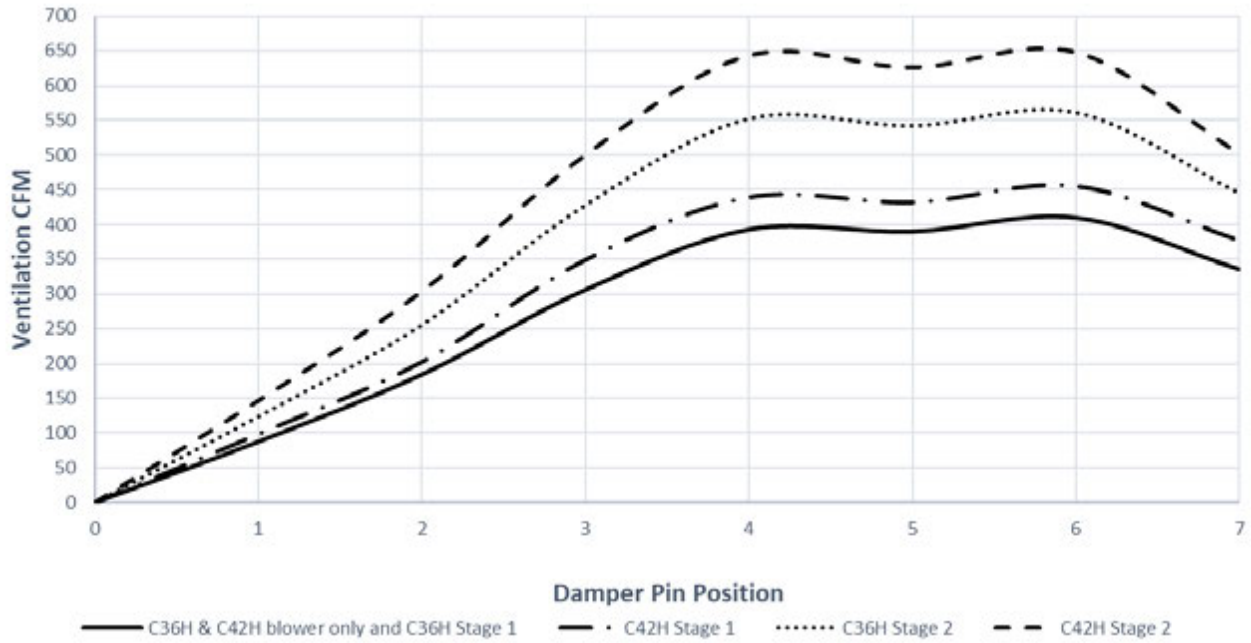

GRAPH 4
C48H & C60H CRV-FS Ventilation Delivery

