



# Literature Assembly

## 911-0917

Contains the following:

2100-034(G)	User's Guide
2100-810	Safety, Service, & Decomm Wall
2100-822	Mount PKG A/C Manual
2110-1487	Replacement Parts Manual
7960-960	Supplemental Dehum Instructions
7960-420(A)	Warranty





# USER'S APPLICATION GUIDE AND TECHNICAL PRODUCT OVERVIEW

Manual: 2100-034G  
Supersedes: 2100-034F  
Date: 12-17-20

Bard Manufacturing Company, Inc.  
Bryan, Ohio 43506  
[www.bardhvac.com](http://www.bardhvac.com)



[BARDHVAC.COM](http://BARDHVAC.COM)

Climate Control Solutions

## General Information

The User's Application Guide covers a wide range of heating and cooling products manufactured by Bard Manufacturing Company. It is intended to be a general guide for care and operation of typical systems and covers the most important features you should be aware of and are responsible for as the user of the equipment.

Because our product offerings are so varied and can be equipped with many features and options, it is not possible to cover all aspects of what your specific system may be configured for. Some systems may be quite simple in features to provide basic cooling and possibly heating, while other systems may also incorporate various ventilation technologies, dehumidification circuits and many different internal controls as well as room temperature controls. Therefore, you should request a detailed operation sequence and explanation of any special features from your installer and/or service company and also have them instruct you as to any routine maintenance procedures you are responsible for.

## Contents

<b>Overview .....</b>	<b>3</b>	<b>Unit Operation .....</b>	<b>18</b>
<b>Documentation .....</b>	<b>4</b>	Air-to-Air Cooling Products (Air Conditioners) .....	18
Unit Literature Assembly – Documentation Provided with Your Units .....	4	Air-to-Air Cooling and Heating Products (Heat Pumps) .....	18
<b>Unit Installation .....</b>	<b>5</b>	Cooling Mode .....	18
WALL MOUNT Products – Mounting the Product on Wall Surface .....	5	Heating Mode .....	18
WALL MOUNT Products – Clearances for Outdoor Condenser Fan Airflow .....	6	Water-to-Air Cooling and Heating Products (Geothermal Heat Pumps) .....	19
WALL MOUNT Products – Clearances for Indoor Supply and Return Airflow .....	6	Cooling Mode .....	19
WALL MOUNT Products – Condensate and Defrost Drainage .....	7	Heating Mode .....	19
I-TEC and Q-TEC Products – Installing the Product Inside a Room .....	8	Water Supply Systems .....	19
I-TEC and Q-TEC Products – Clearances for Outdoor Condenser Fan Airflow .....	8	<b>Dehumidification and Ventilation Operation .....</b>	<b>20</b>
I-TEC and Q-TEC Products – Clearances for Indoor Supply and Return Airflow .....	9	Dehumidification (Air-to-Air or Water-to-Air Systems) .....	20
I-TEC Air Path .....	9	Ventilation Options (Air-to-Air or Water-to-Air Systems) .....	20
Q-TEC Air Path .....	9	<b>Troubleshooting .....</b>	<b>21</b>
I-TEC and Q-TEC Products – Condensate Drainage .	10	All Units – Troubleshooting .....	21
All Products – Power Supply Verification .....	11		
Field-Supplied Voltage .....	11		
Single and Three Phase Power .....	11		
Hertz (Frequency) .....	11		
<b>Unit Maintenance .....</b>	<b>12</b>		
All Products – Filters and Filter Servicing .....	12		
Outdoor Unit Wall Mount Room Air Filters .....	12		
WALL MOUNT Products – Filters and Filter Servicing .....	13		
I-TEC Indoor Products – Filters and Filter Servicing .....	14		
Q-TEC Indoor Products – Filters and Filter Servicing .....	15		
All Products – Coil Cleaning .....	16		
Equipment Corrosion Protection .....	16		
All Products – Condenser Airflow .....	17		

The User's Application Guide and Technical Product Overview covers the following products:



WALL MOUNT  
Air Conditioners  
and Heat Pumps



I-TEC®  
Air Conditioners  
and Heat Pumps



Q-TEC™  
Air Conditioners  
and Heat Pumps

The User's Application Guide and Technical Product Overview covers the following topics:

- Documentation provided by Bard for proper use of your new product.
- Unit installation guidelines.
- Routine unit maintenance.
- Unit operation.
- Unit troubleshooting.

Please use this guide as a general overview regarding unit application, maintenance and troubleshooting. Refer to product installation instructions and supplemental documentation provided with the unit or go to [www.bardhvac.com](http://www.bardhvac.com) for detailed individual product information.

## Documentation

There are two sources of valuable information for your new Bard product:

- Documentation provided with your unit, normally located inside the unit control panel during shipping. This information should be saved once the unit is installed for future maintenance reference or to answer questions about equipment after installation.
- Documentation provided on the internet at [www.bardhvac.com](http://www.bardhvac.com). This may be accessed from a desktop computer at the office, a laptop or an internet-capable cell phone at the worksite. Up-to-date documentation is available, along with specification sheets and other valuable resources regarding your new Bard product.

### **Unit Literature Assembly – Documentation Provided with Your Unit**

Bard products are shipped with documentation that when used by a technician with cooling and heating knowledge, can ensure that your product is installed safely, performs optimally and achieves the longest life cycle possible.

Shipped literature includes the following:

- User Manual (this document)
- Installation Instructions
- Replacement Parts Manual
- Wiring Diagrams
- Warranty Information

Installation plays a key part in unit functionality, performance and safety. Product securing and placement, duct design and supply/return location, electrical routing and condensate and defrost drainage all play key roles in making sure a unit will perform per the design specifications.

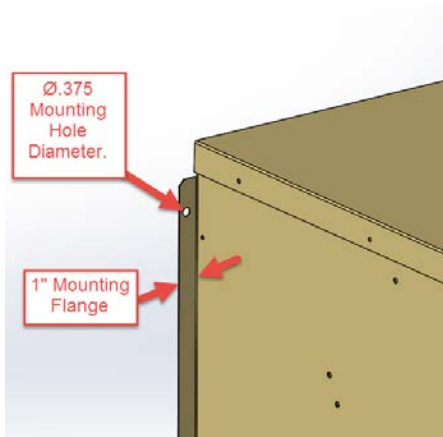
## WALL MOUNT Products – Mounting the Product on a Wall Surface



Outdoor products are normally mounted to an exterior wall surface, including brick, cement block, metal or wood construction. These products are labeled as “WALL MOUNT” units. **Before installation begins, the wall surface should be inspected by a construction professional to ensure it will support the weight of the unit and accessory items.** Approximate weights are available from the product specification sheet, and a safety factor should be designed into the installation. Typical fasteners to attach the unit to the wall using the integrated mounting flanges on both sides of the unit include tap cons, bolts, studs and other fastening devices. The selection of the fasteners to be used needs to be reviewed by a construction professional and decided upon based on the wall construction and fastener strength required. It is important to follow all guidelines and procedures covered in the installation instructions manual provided for the product.

### Built-In Mounting Flange Detail:

Outdoor WALL MOUNT products include a mounting flange that is part of the cabinet construction.  $\varnothing.375$ " holes are provided for unit mounting unless specified otherwise in installation instructions.



### Specification Sheets:

Unit specification sheets provided at [www.bardhvac.com](http://www.bardhvac.com) include basic unit weights and dimensions (see example below). Ventilation options and other accessories must be added into the total weight of the unit.

### Specification Sheet Example

w/Filter (Rated-wet Coil)	
Filter Sizes (inches) STD.	16x25x1
<b>Basic Unit Weight-LBS.</b>	<b>318</b>
Barometric Fresh Air Damper	3.5
Blank-Off Plate	1.0
Motorized Fresh Air Damper	10.0
Commercial Room Ventilator	69.0
Economizer	69.0
Energy Recovery Ventilator	50.0

## **WALL MOUNT Products – Clearances for Outdoor Condenser Fan Airflow**

Unit placement and avoidance of obstructions outside the structure are very critical to unit performance. **Avoid installing the unit in areas that will obstruct outdoor condenser fan airflow or create “pockets” of heated air being exhausted from the condenser coil.** Solid construction fences should not be placed directly in front of the unit without provisions for condenser airflow. Solid exterior walls need to be spaced as far away from units as possible to avoid pockets of heated air causing condenser air recirculation.

Solid barriers located too close to the face or side surfaces (condenser fan inlet and outlet) of the WALL MOUNT can both impede airflow and force heated air to short circuit (be returned) from the condenser outlet to the condenser inlet. Either condition will effectively raise the condensing temperature and pressure reducing cooling capacity and efficiency. In extreme cases, the unit may fail to operate due to high refrigerant pressures inside the unit, and compressor and/or fan motor failure may occur. Clearances given in installation instructions ensure components can be serviced and maintenance can be performed when needed.

National and local electrical codes must be reviewed before unit installation.

Always use common sense when installing products, follow unit clearances given in the installation instructions and contact local Bard distributors when additional knowledge is needed regarding unit clearances for proper unit functionality.

## **WALL MOUNT Products – Clearances for Indoor Supply and Return Airflow**

The Bard unit should be placed in an area where the supply (leaving conditioned air) and return (unit air intake) air paths will be unrestricted. Avoid placing objects in the structure within 24" of the return (unit air intake) grille. Avoid placing objects directly in the path of the supply (conditioned) air grille. This will inhibit the “throw” of the supply air throughout the structure and reduce the cooling and/or heating ability of the unit; in extreme cases, this may cause evaporator coil freezing issues. Supply air must be able to freely circulate conditioned air throughout the structure. Adjustment of supply grille deflectors is often necessary to ensure proper room circulation.

Ducted applications should not exceed the rated duct static pressures given in the unit specification sheets. Special requirements for duct construction and distances to combustible materials need to be followed per the installation instructions when electric heating is used.

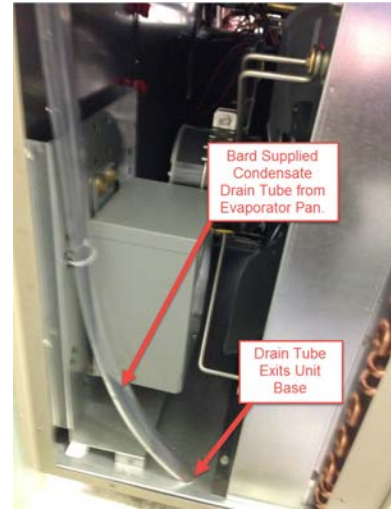
## WALL MOUNT Products – Condensate and Defrost Drainage

Condensate drainage for air conditioning units needs to be planned before installation. Your new Bard WALL MOUNT product includes provisions to allow condensate water to exit the bottom of the unit. If condensate water is to be routed away from the unit, adequate drain sizing needs to be provided to allow proper drainage for condensate water generation. During normal air conditioning operation, large amounts of condensate water is generated inside the unit as moisture is extracted from the supply air. This is collected in an evaporator pan and drained to either a drainage system (indoor products) or outside the unit cabinet (outdoor products). Evaporator drain traps are not necessary for any of our wall mounted outdoor products, and the use of “standing water” U-shaped traps may be prone to freezing in certain climate zones.

Defrost water drainage from heat pump units needs to be planned before installation. During seasons requiring heating operation, the unit will need to warm the condenser coil to remove frost build-up (defrost). **Outdoor heat pump products include holes in the unit base under the condenser coil for proper water drainage when in the heating defrost cycle. Avoid placing the unit on a pad or blocking the base drainage holes under the condenser coil without proper allowances (6" recommended) for water drainage due to damage caused by freezing conditions.** Without proper drainage, defrost water may freeze causing ice build up and damage the lower portion of the condenser coil.

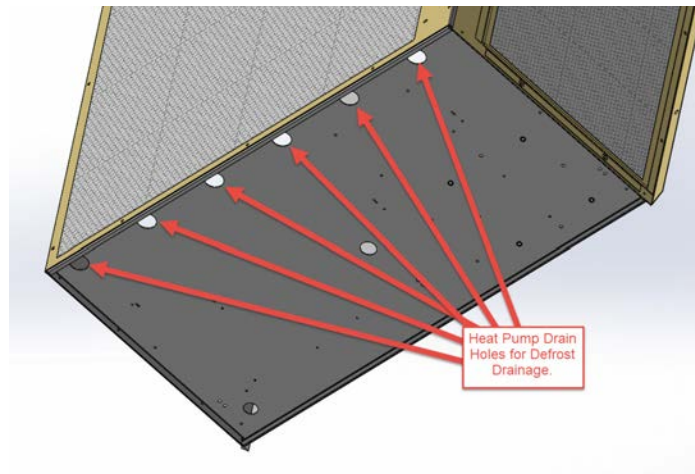
### Condensate Water Drainage:

Unit condensate water exits the base of the unit during cooling operation.



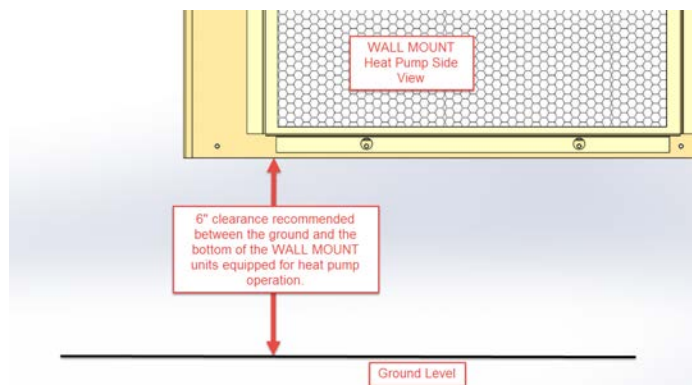
### Defrost Water Drainage:

Holes are provided in the front of the unit base for heat pump condensate water drainage.



### Defrost Water Drainage:

6" clearance is recommended under WALL MOUNT Heat Pump products to allow proper defrost water drainage.



## I-TEC and Q-TEC Products – Installing the Product Inside a Room



I-TEC



Q-TEC

Indoor products are normally supported by the floor surface and are adjacent to an interior wall surface, including brick, cement block, metal or wood construction. These products are normally labeled as “I-TEC” or “Q-TEC” units. **Before installation begins, the floor surface should be inspected by a construction professional to ensure it will support the weight of the unit and accessory items.** Approximate weights are available from the product specification sheet, and a safety factor should be designed into the installation.

A sheet metal sleeve is normally installed in the wall allowing vent and condenser fan air to enter and exit the unit. Different sleeve depths are available for installation into various wall depths. Typical fasteners to attach the sleeve to the outside surface of the wall include tap cons and other fastening devices. The I-TEC or Q-TEC unit is then slid up to the wall surface and connected to the sleeve using screws. Trim kits are available to enclose gaps between the wall surface and the unit. A louver grille is used to cover the external wall opening and fasteners used during sleeve installation.

### Wall Sleeve:

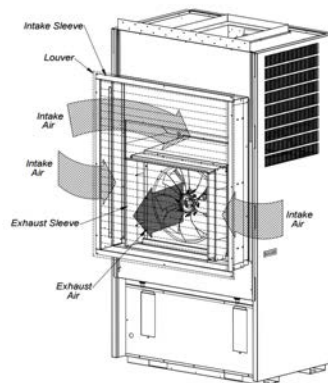
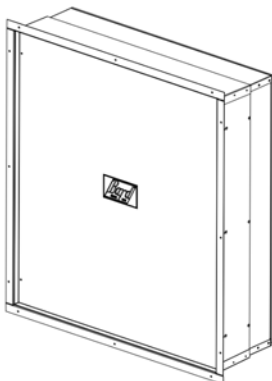
Wall sleeves allow for outdoor air to enter and exit the unit inside the room.

### Air Paths:

Air paths through the unit allow for cooling operation and fresh air to enter the structure (I-TEC shown).

### Louver Installation:

Outdoor louvers provide an esthetically pleasing look to the installation and cover the unit opening (I-TEC shown).



## I-TEC and Q-TEC Products – Clearances for Outdoor Condenser Fan Airflow

Solid barriers located too close to the face of the outdoor louver of the I-TEC or Q-TEC can both impede airflow and force heated air to short circuit (be returned) from the condenser outlet to the condenser inlet. Either condition will effectively raise the condensing temperature and pressure reducing cooling capacity and efficiency. In extreme cases, the unit may fail to operate due to high refrigerant pressures inside the unit, and compressor and/or fan motor failure may occur. It is recommended to allow 15' (457.2 cm) in front of unit louver for proper condenser airflow. Always use common sense when installing products, follow unit clearances given in the installation instructions and contact local Bard distributors when additional knowledge is needed regarding unit clearances for proper unit functionality.

## I-TEC and Q-TEC Products – Clearances for Indoor Supply and Return Airflow

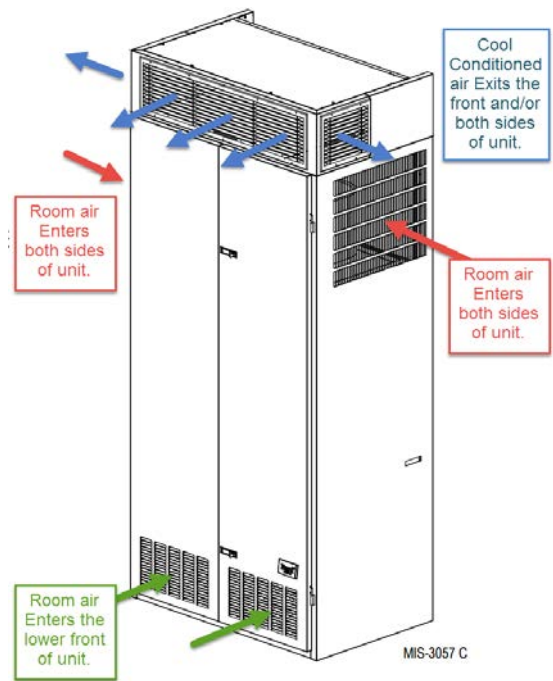
The Bard unit should be placed in an area where the supply (leaving conditioned air) and return (unit air intake) air paths will be unrestricted. Avoid placing objects inside the room within 24" of the return (unit air intake) louvers or grille. Avoid placing objects directly in the path of the supply (conditioned) air grilles. This will inhibit the “throw” of the supply air throughout the structure and reduce the cooling and/or heating ability of the unit and in extreme cases may cause evaporator coil freezing issues. Ducted applications should not exceed the rated duct static pressures given in the unit specification sheets. Special requirements for duct construction and distances to combustible materials need to be followed per the unit installation instructions when electric heating is used.

### I-TEC Air Path

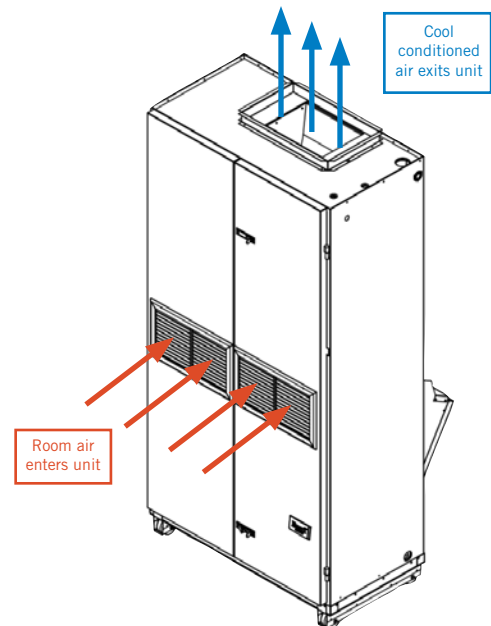
The I-TEC product has been engineered for extremely quiet unit operation and has multiple air paths for air entering and exiting the unit. Room air enters the upper sides to be conditioned (cooled) inside the unit and exits the unit top. The unit will either be ducted to supply registers or have a supply air plenum box installed. A supply air plenum box allows quiet operation without ducting the air leaving the unit. Room air also enters the bottom of both front doors during ventilation operation.

### Q-TEC Air Path

The Q-TEC product has been engineered for efficient, economical unit operation and has a mid-mounted front grille for air entering the unit. The unit will either be ducted to supply registers or have a supply air plenum box installed. A supply air plenum box allows quiet operation without ducting the air leaving the unit.



*Typical I-TEC Installation*



*Typical Q-TEC Installation*

The I-TEC and Q-TEC product installation instructions contain additional information regarding unit air paths and required clearances. This information may be accessed at [www.bardhvac.com](http://www.bardhvac.com).

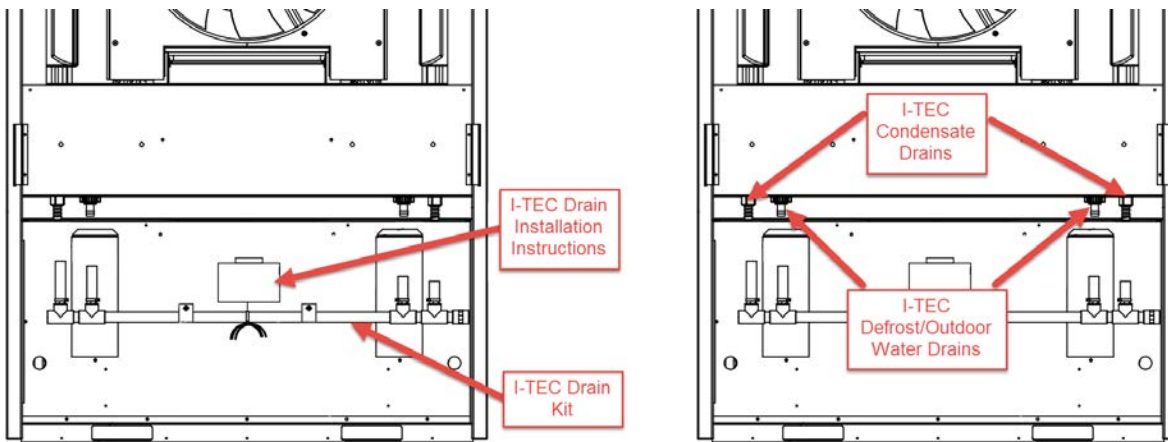
## I-TEC and Q-TEC Products – Condensate Drainage

Condensate drainage for Bard indoor cooling units is a very important part of unit installation. During normal air conditioning operation, large amounts of condensate water are generated inside the unit as moisture is extracted from the supply air. This is collected in an evaporator pan and needs to be drained to an external drainage system. Your new Bard product includes provisions to allow condensate water to exit the unit and fittings will need to be field supplied to connect the unit drain to the building. Adequate drain sizing needs to be provided to allow proper drainage for condensate water generation and restriction in drain lines should be avoided. Evaporator drain traps are not necessary unless required by local codes.

Defrost water for heat pump operation and outdoor water entering the condenser area also needs to be drained out of the unit. The I-TEC product uses a combined defrost and outdoor water drainage system. The Q-TEC has a combined defrost and evaporator drain connection unless an optional in-wall drain box is used. Outdoor water exits the Q-TEC through the wall sleeve. Follow all instructions provided in the unit installation instructions regarding drain connections and sleeve installation to avoid water leakage inside the building or structure.

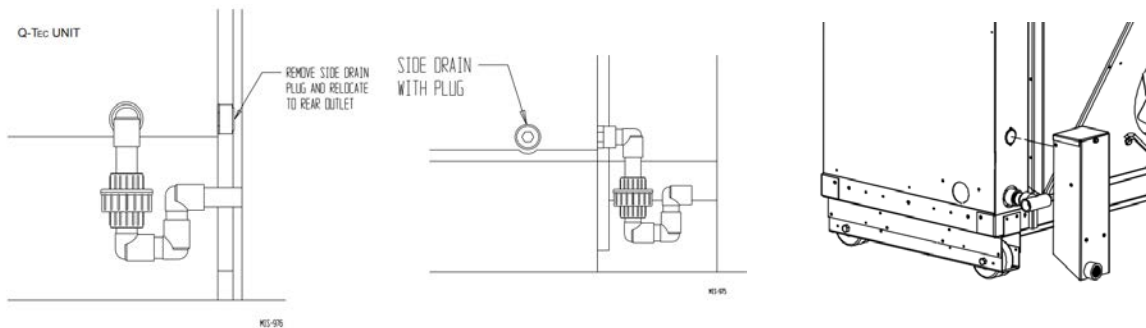
### I-TEC Drain System:

The I-TEC drainage system consists of a manifold drain kit that combines all drains behind the unit to allow connection to the building system.



### Q-TEC Drain System:

The Q-TEC drainage system consists of a lower right side or lower right rear connection fitting. An optional in-wall drain box may also be purchased as an accessory that allows separate evaporator and defrost water drainage.



Lower Right Side Drain

Lower Right Rear Drain

Optional In-Wall Drain Box

## All Products – Power Supply Verification

It is very important to follow all electrical and mechanical safety guidelines and instructions provided in the product installation instructions. Failure to do so may result in death, injury or product damage.

A proper power supply to your new Bard unit is very important. Be sure to verify the following with a multi-meter or other power measuring device before applying power to your Bard product.

### *Field-Supplied Voltage*

Electrical voltage ratings and proper voltage operating ranges are provided in the unit specification sheets and installation instructions. It is important that power supplied to the unit stay in the specified operating voltage range. Voltage above or below the minimum operating value given could result in improper unit startup, unit shutdown, low unit performance, improper thermostat and unit controller operation, compressor damage and premature failure of functional parts. As a general guideline, it is always best if the power source for the unit supplies the nominal electrical rating value given in the specification sheets, installation instructions and unit serial plate for the product being used. To do so will provide the best unit performance possible from your new Bard product.

### *Single and Three Phase Power*

Bard products are available in single and three phase power options. It is important to connect the proper phase listed on the unit serial plate. Three phase power is often used to reduce energy usage, and units rated for 3 phase operation are equipped with a phase monitor safety device. The phase monitor will not allow unit operation with improper phase connection and a red LED light on the monitor indicates phase wiring issues. Connecting 3 phase power to a single phase unit will result in component damage and improper unit operation. Connecting single phase power to a 3 phase unit will also result in component damage and improper unit operation.

### *Hertz (Frequency)*

Bard products are available in 50hz and 60hz power options. It is important to connect power with the proper hz value listed on the unit serial plate. 60hz power is often used in the United States and Canada and units rated for 50hz operation are normally for international sales outside of this area. Connecting 50hz power to a 60hz unit not rated for 50hz operation may result in component damage and improper unit operation. Some equipment may be rated for 50/60hz operation. Review the unit specifications and installation instructions for further information regarding the power requirements of the unit.

The product installation instructions and unit specification sheets contain additional information regarding unit electrical data. This information may be accessed at [www.bardhvac.com](http://www.bardhvac.com).

# Unit Maintenance

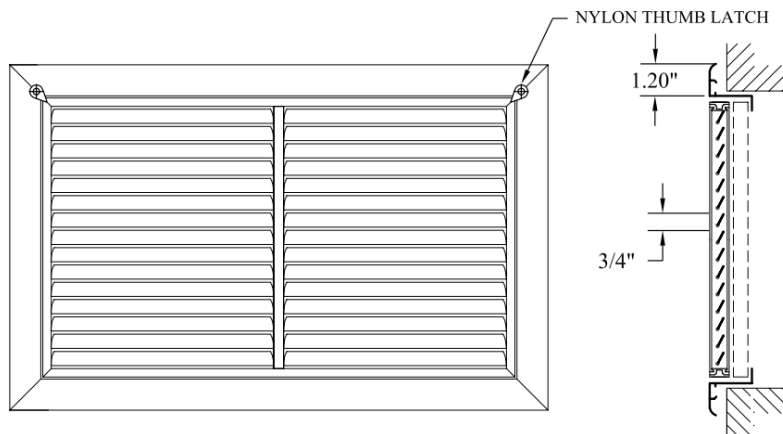
## All Products – Filters and Filter Servicing

All Bard products contain air filters that must be cleaned or replaced on a regular basis.

Keeping air filter(s) clean is the single most important responsibility of the user of the equipment. Each type of system must be equipped with an air filter(s) in the indoor circulating air system to clean the air, keep the system itself clean for peak efficiency and capacity and prolong the useful life of the equipment. DO NOT operate the system without the proper air filters. Filters should be inspected at least monthly and replaced or cleaned (depending on type) as needed. The useful life of an air filter can vary widely depending upon application and use of the equipment, and it is critical to monitor filter condition and establish an acceptable maintenance schedule. Failure to do so will increase operating and repair costs, decrease capacity and efficiency and shorten the service life of the equipment. A common symptom of a dirty filter in the cooling mode is a freeze-up of the indoor coil. The air filters used may be a disposable (throwaway) type or may be a cleanable type that can be thoroughly cleaned, rinsed and reused many times. It is important to make sure that the correct filter size and type for your system is always used. If there is any question as to acceptable filter size or type, review the installation instructions for the specific equipment involved, if available. Otherwise, consult with your installing dealer or service company. Most equipment can have the filters inspected and serviced by the user with no problems. In some instances, because of equipment design or specific installation conditions, it may be necessary to have this procedure done by a qualified service company. Have your installer or service company show you where the filter(s) are and demonstrate the service procedure or make arrangements for them to provide this service on an as-needed basis.

### Outdoor Unit Wall Mount Room Air Filters

Wall mount filters are normally accessed from the outside of the building. Bard does offer a return air grille with a filter frame built-in for indoor filter access. The return air filter grille is not acceptable as the only source of filtration if vent options are installed in the wall mount unit.



### Return Air Filter Grille:

*Bard offers the RFG return air filter grille, which may be used in applications where outdoor air is not brought into the structure through vent options. If vent options are used, the filter tray inside the Bard Wall Mount unit must be used.*

The product installation instructions contain additional information regarding unit maintenance. This information may be accessed at [www.bardhvac.com](http://www.bardhvac.com).

## WALL MOUNT Products – Filters and Filter Servicing

The built-in filter tray and room air filters in the wall mount are located in the middle of the cabinet below the indoor blowers. Units with vent options will have a washable screen behind the vent intake panel.



**Filter Door:**

*The unit room air filter is located behind this panel for units without a vent hood.*

**Vent Intake Panel**



**Vent Intake Panel**

**Vent Hood Door:**

*The unit indoor filter is located behind this panel for units with a vent hood. The hood contains a washable pre-filter that needs to be cleaned regularly.*

**Filter Door:**  
*The unit room air filter is located behind this panel.*



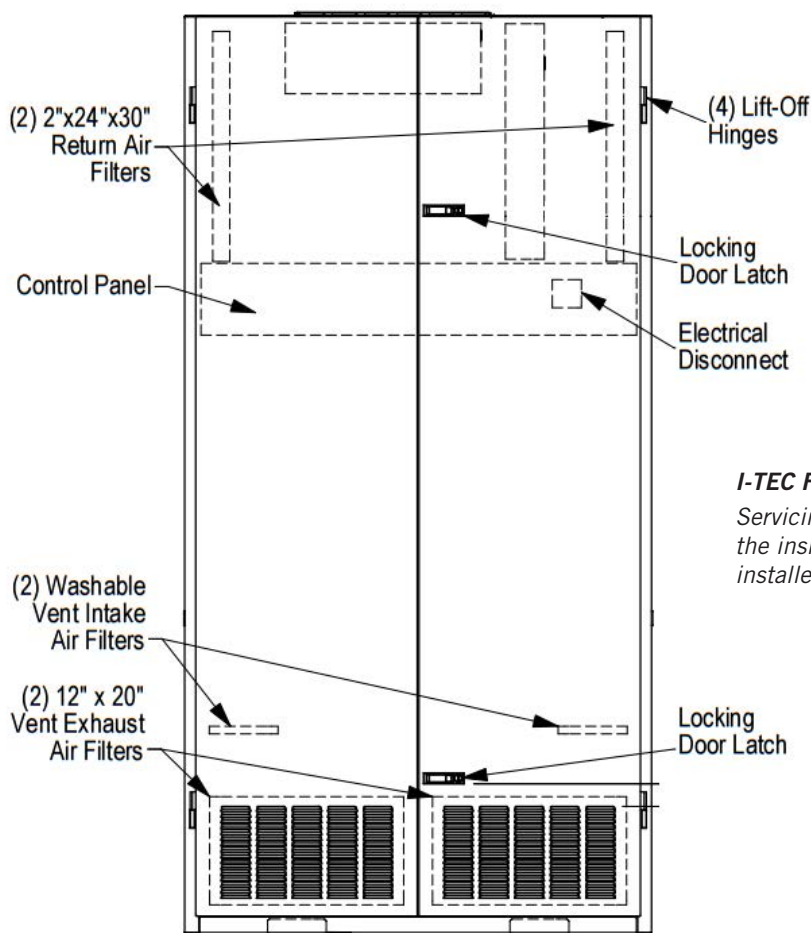
## I-TEC Indoor Products – Filters and Filter Servicing

The I-TEC indoor air conditioners and heat pumps have multiple filters that must be maintained and inspected when servicing the unit. Filters play an important part in proper unit operation and prevent dirt and dust buildup inside the I-TEC and the room the unit is installed in. To access the unit filters, open the front hinged doors by unlocking the door latches. The doors fold outward and are on hinges with lift-off pins. Use care when opening doors. If doors are lifted off of the hinge pins, use care as the dense insulation used for sound reduction causes the doors to be heavy.

The upper section of the unit contains two 2" x 24" x 30" throwaway filters as standard with every unit. MERV ratings of the filter are available up to MERV13. These filters filter the air used for cooling inside the classroom or structure and should be changed regularly.

If the unit has an air intake vent option installed, two 1" x 12" x 20" filters are located in the lower section of the front doors behind the louvers. These filters help keep the vent option clean and operating properly.

Two washable filters are also installed in the air intake vent option. These should be inspected during servicing and cleaned when necessary. The washable filters are used to remove dirt and dust from outdoor air that is entering the vent area. If at any time these filters are damaged, they must be replaced with Bard-approved filters.



### ***I-TEC Filter Locations:***

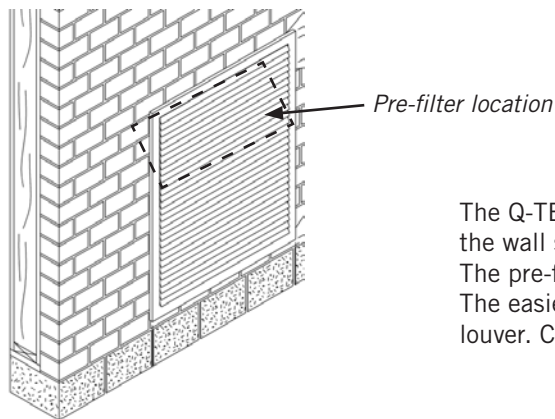
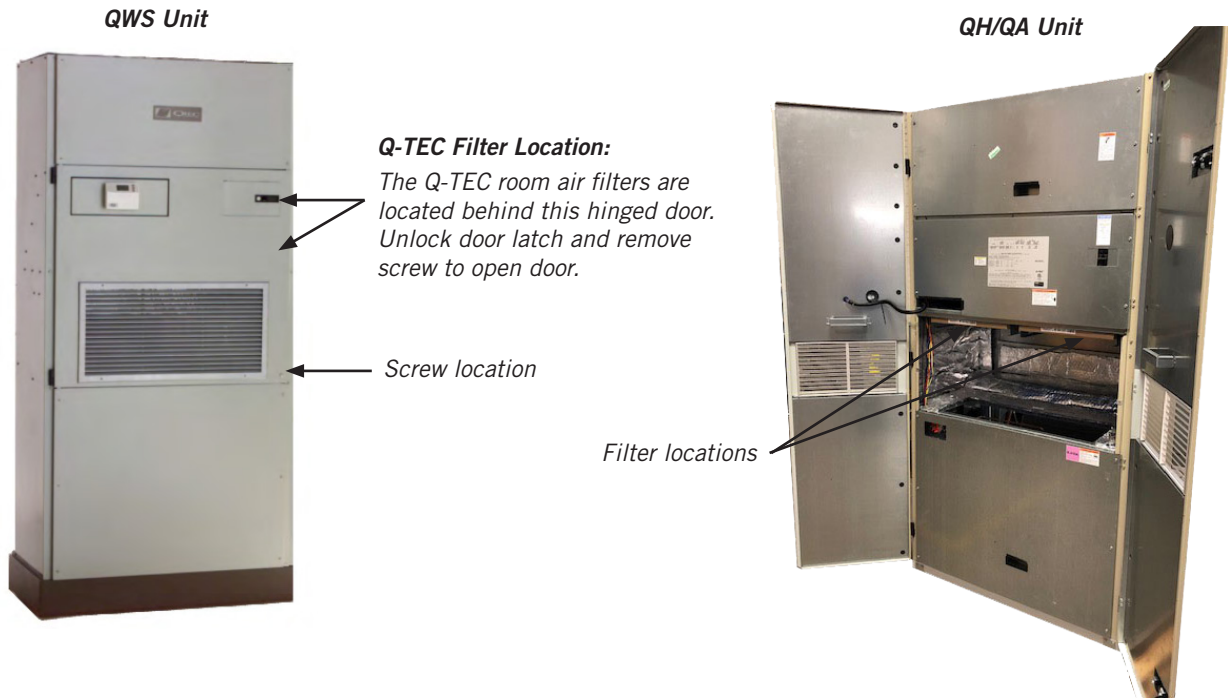
*Servicing the filters in your unit will help keep the inside of the unit clean and also the area it is installed in.*

The I-TEC product installation instructions contain additional information regarding unit maintenance. This information may be accessed at [www.bardhvac.com](http://www.bardhvac.com).

## Q-TEC Indoor Products – Filters and Filter Servicing

The Q-TEC indoor air conditioners and heat pumps have two room air filters that must be replaced when servicing the unit. Filters play an important part in proper unit operation and prevent dirt and dust buildup inside the Q-TEC and the room the unit is installed in. To access the unit filters, open the front hinged door by unlocking the door latch. The door folds outward and is on hinges with lift-off pins. Use care when opening doors. If the door is lifted off of the hinge pins, use care as the insulation and louver grille cause the door to be heavy.

The upper section of the Q-TEC contains two 1" throwaway filters standard with every unit. These filters filter the air used for cooling inside the classroom or structure and should be changed regularly.



The Q-TEC will have a permanent pre-filter installed inside the wall sleeve if air intake vent options are inside the unit. The pre-filter must be inspected and cleaned when necessary. The easiest way to remove the pre-filter is through the outdoor louver. Clean the pre-filter with soapy water.

The Q-TEC product installation instructions contain additional information regarding unit maintenance. This information may be accessed at [www.bardhvac.com](http://www.bardhvac.com).

## All Products – Coil Cleaning

The outdoor coil must be kept clean and free of any airborne debris, which can accumulate over time. Large volumes of air are circulated over the coil, and airborne debris such as lint, dust, materials shed from trees, paper or other types of airborne material that can become airborne can collect on the entering coil surface. The outdoor coil must dissipate heat during the cooling mode and for a heat pump, also absorb heat during the heating mode. If the coil is dirty and matted with debris, the airflow across the coil will be reduced causing poor performance, increased operating run time and associated utility bills and in extreme conditions can shorten the useful life of the equipment.

Depending on the specific equipment involved, the surface that can accumulate debris can be on the opposite side that is exposed to view when standing in front of the machine. Closely review the machine when operating to see which direction or path the airflow takes as it moves through the machine. If the air inlet side of the coil is hidden, try to observe the back (hidden) side by looking into the side grilles, using a flashlight if necessary. While the user of the equipment needs to be aware of the potential of clogging of the outdoor coil surface, actual cleaning of the outdoor coil should not be attempted under most circumstances. If the user should attempt this procedure on their own, never do so without first having the installing dealer or service company instruct you in the proper procedure and technique.

**WARNING: Do not open or enter the equipment without first turning off the electrical service disconnect. Failure to do so can result in personal injury due to moving parts and/or electric shock hazard resulting in death.**

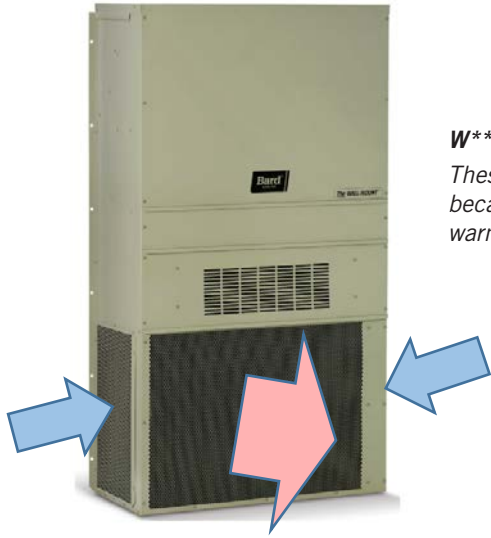
Other conditions that can cause reduction of airflow across the outdoor coil are flowers, shrubbery or other growth too near the outdoor coil air inlet and outlet openings. These living things, especially as they mature and grow, will be just as effective in blocking the airflow and create the same problems as will stacking things against the equipment. These conditions can be easily managed and controlled by the user, as they do not require actually entering into the equipment enclosure, which should only be done by qualified service technicians.

### **Equipment Corrosion Protection**

1. Avoid having any lawn sprinkler spray directly on the equipment, especially if from a brackish water source.
2. In coastal areas or corrosive environments, locate equipment as far away from the corrosion source as feasible. Units exposed directly to salt spray should be coated by a secondary protective coating operation to reduce corrosion on copper tubing, fasteners, motors and other metal parts. Coils should be ordered with a corrosion protective coating. Contact Bard for coating options.
3. Frequent cleaning and waxing of the cabinet using a good automobile polish will help extend its original appearance and protect painted surfaces.

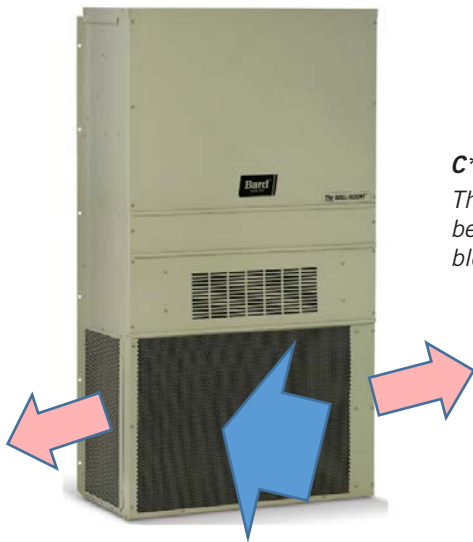
The product installation instructions contain additional information regarding unit coil cleaning. This information may be accessed at [www.bardhvac.com](http://www.bardhvac.com).

## All Products – Condenser Airflow



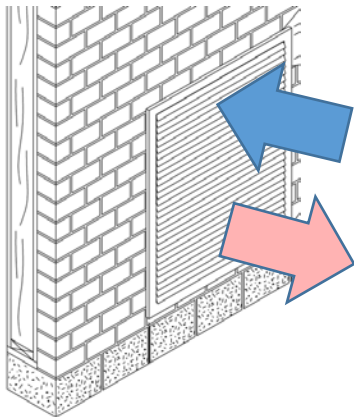
### **W\*\*A, W\*\*H, T\*\*H, T\*\*S, W\*RV Wall Mount Units:**

*These units are called “blow through condenser airflow” units because they draw cool outdoor air from the sides and blow the warm condenser air exiting the coil through the front grille.*



### **C\*\*H Wall Mount Units:**

*These units are called “draw through condenser airflow” units because they draw cool outdoor air in the front through the coil and blow the exiting warm condenser air through the unit sides.*



### **I-TEC and Q-TEC Units:**

*These units draw the cool outdoor air through the top section of the wall louver and exhaust the warmer condenser air out of the lower section of the louver. I-TEC units also draw a small amount of air through the outer right and left side of the louver.*

# Unit Operation

## Air-to-Air Cooling Products (Air Conditioners)

The cooling mode operates similar to a refrigerator, removing heat from inside the conditioned space and rejecting it outside of the space being controlled. There are three main parts of the system:

1. The evaporator (indoor) coil where cold refrigerant absorbs heat from the air, which circulates from the conditioned space through the machine and is returned to the space at a lower temperature and with some of the humidity (moisture) removed. The moisture exits through a condensate drain system. A motor/blower assembly moves the indoor air through the system.
2. The compressor, which is a sealed pump that moves the refrigerant through the system.
3. The condenser (outdoor) coil where the heat that was absorbed from the indoor space is discharged to the outdoor environment. A motor/fan system moves the outdoor air across the condenser coil. A properly sized air conditioner cannot cool a structure off rapidly and instead will pull down the temperature slowly. It also will remove a certain amount of moisture (humidity) from the circulating airstream in the process. It may take several hours to pull down a hot, moist building or structure on initial startup or anytime the system has been turned off for a long period of time. It is generally best to set the thermostat at a comfortable temperature and let it control the system as needed, rather than turning it on and off.

Moisture (humidity) removal with a conventional air conditioner (cooling) unit, or heat pump when operating in the cooling mode, is not directly controlled and is a by-product of the unit operating to control temperature in response to the temperature (thermostat) control device. **Oversized equipment can easily control temperature but will have short run-times, thus reducing its ability to remove moisture from the circulating air stream.**

There are also many additional influences that can affect humidity levels within the conditioned space such as laundry appliances, cooking, showers, exhaust fans and any other items that can generate moisture or affect its removal from the space. Therefore, while operation of the air conditioning or heat pump system in the cooling mode will remove some amount of moisture as it reduces the air temperature, precise humidity regulation in the conditioned space cannot be assured and additional equipment such as a dedicated dehumidifier may be required.

## Air-to-Air Cooling and Heating Products (Heat Pumps)

A heat pump is a refrigerant-based system that has additional components and controls that both heats and cools using a compressor for both modes of operation. Most heat pumps will also be equipped with some amount of electric heat to supplement the heating capacity of the compressor system on an as-needed basis. This operation is entirely automatic and is controlled by the indoor thermostat and possibly also an outdoor thermostat.

### **Cooling Mode**

The cooling mode of a heat pump is exactly the same as that described for an air conditioner in the above section.

### **Heating Mode**

The system operates in reverse cycle, meaning that it absorbs and moves heat from the outdoors and transfers it indoors to be rejected into the circulating air stream. Even though it seems cold to humans, there is usable heat that can be extracted efficiently from the outdoor air down to 0°F, although the colder the air is there is less heat to extract and the operating efficiency is diminished.

### **Defrost Cycle**

When operating in the heating mode, the outdoor coil will be colder than the outdoor air that is forced over it by the fan system. When the outdoor air temperature is above approximately 40°F, moisture can accumulate on the coil and it will drain down and out the base of the unit. As the air temperature gets below approximately 40°F, the coil temperature will start to drop below 32°F, and frost or ice will begin to form on the coil.

An automatic defrost system keeps track of system run time when the outdoor coil temperature is in the freezing zone and will initiate a defrost cycle at the appropriate time. The unit continues to operate during the defrost cycle, but the outdoor fan motor will stop and the reversing valve will shift positions to flow hot refrigerant gas through the outdoor coil to melt the accumulated frost. Water will start to drain freely from the unit, and steam may be emitted from the unit.

The length of the defrost cycle will vary depending upon actual outdoor temperature, humidity levels and amount of accumulated frost. It could range from 1-2 minutes up to but not exceeding 8 minutes. When the defrost cycle

terminates, the reversing valve will shift back to heating mode and the outdoor fan will restart. There is typically a large puff of steam emitted as the fan restarts. When the heat pump shifts from cool to heating mode, from heating to cooling mode and especially during defrost cycles, there will be a pressure transfer sound heard as the reversing valve redirects the flow of refrigerant. This is commonly described as a hissing noise and is a normal sound for this type equipment.

For air source heat pumps, it is important to keep heavy snow from accumulating around the machine to the point of blocking the inlet and outlet openings to the outdoor coil section. For wall mounted or other equipment that is elevated, this should not be a factor; but for equipment installed on or near the ground, this can be an issue in areas prone to heavy and/or blowing snow. The air source heat pump cannot operate effectively and efficiently when snowbound just as a car cannot function well in heavy snow conditions.

### ***Water-to-Air Cooling and Heating Products (Geothermal Heat Pumps)***

These types of heat pumps are also commonly referred to as water source or geothermal systems. Just like the air source heat pump, they are refrigerant-based systems that both heat and cool using a compressor for both modes of operation. The primary difference is that the system uses water or antifreeze-protected water solution instead of an air-cooled outdoor heat transfer coil, and there is no outdoor motor/fan system but instead a water pump to provide adequate water flow to the system.

#### ***Cooling Mode***

The cooling mode of a water-to-air heat pump is exactly the same as that described for an air conditioner in the previous Air Conditioner section, except that the outdoor coil uses water instead of air for the heat transfer medium.

#### ***Heat Mode***

The system operates in reverse cycle, meaning that it acquires and moves heat from the water supply flowing through the water to refrigerant coil and transfers it indoors to be rejected into the circulating air stream.

Most water-to-air heat pumps (but not all) will also be equipped with some amount of electric heat to supplement the heating capacity of the compressor system on an as-needed basis. This operation is entirely automatic and is controlled by the indoor thermostat.

Because of the design of water-to-air heat pumps and the water temperatures involved, no defrost system is required as in air-to-air heat pumps.

#### ***Water Supply Systems***

Depending upon the type and application of the water-to-air heat pump, the water side of the system could be one of the following:

1. Individual closed loop buried in a trench or vertical bore hole(s).
2. Individual loop submerged in a pond.
3. Water supplied from a well and discharged into pond, stream, ditch or another well.
4. Water supplied from a boiler/tower system, typically only in larger multi-unit installations.

## Dehumidification and Ventilation Operation

### Dehumidification (Air-to-Air or Water-to-Air Systems)

Many Bard systems, typically those used in schools or other commercial applications, have a dedicated dehumidification capability by having a special additional refrigeration circuit (factory-installed option only) in addition to the basic system. These special systems, sometimes also referred to as hot gas reheat, are designed to control humidity on demand from a humidity controller much the same as the basic cooling and/or heating system is controlled by a wall thermostat. Consult your installer and/or service company to determine if your installation has any of these devices and for any instructions or maintenance requirements you should be aware of as the user.

### Ventilation Options (Air-to-Air or Water-to-Air Systems)

All Bard systems are available with factory-installed vent options. Most units can have ventilation field installed after unit installation.

Ventilation has multiple purposes:

- Outside air intake for occupied structures
- Positive pressurization
- Energy savings when outdoor air can be used for cooling
- Agricultural use of bringing in outdoor air and exhausting room air
- Equipment and electronics ventilation

Review product specifications and manuals for more details regarding available ventilation options and features. Product documentation is shipped with the product and also available at [www.bardhvac.com](http://www.bardhvac.com).

## All Units – Troubleshooting

Your Bard product is made to operate for many trouble-free years if installed properly and maintenance practices are followed. Be sure to verify that all filters are clean, and condenser coils are free of dirt and debris. Often these items may look clean at first, but upon closer inspection, show signs of dirt and debris build-up. New units on new structures may have dirt and dust in filters from the building construction process.

Thermostats and unit controllers often contain vent holes for proper sensor measurement inside the device. Make sure the thermostat or controller are not full of dirt and dust from building construction or years of use.

Verify all requirements in the installation instructions and specification sheets are met. Unit voltages, airflow clearance requirements and clean unit power without brownouts or spikes play a critical role in unit performance. If 208 VAC power is supplied to the unit, the 208V tap must be used on the 24 VAC transformer located inside the control panel. Common sense must also be used when installing the unit in an environment that may put the unit at risk of improper operation.

## Helpful Hints and Good Operating Practices

The following information will help you enjoy the full comfort and benefits of your Bard cooling and heating system, maximize the performance and efficiency and help extend the life of your system.

1. Always keep the equipment in peak operating condition with routine scheduled maintenance, especially for the air filters, and to assure a clean outdoor coil.
2. For most efficient operation, set the thermostat at the temperature you prefer and then let it take control. If any changes to the settings are required, they should be made in small adjustments and the system be allowed time to respond. Rapid changes either up or down should not be done.
3. Setting the thermostat very high does not make the system heat faster and setting it very low does not make it cool faster.
4. It is not recommended to turn the system "Off" then back "On" when you need it. This can allow temperature and humidity to build up in warm weather conditions and force the system to run continuously to try and catch up. If the building is to be unoccupied for a lengthy period, it is best to adjust the thermostat to a reasonable higher (or lower—depending on the season) setting rather than turning it completely off. Upon return, the inside conditions will not be totally out of control and recovery time to desired conditions would be much shorter.
5. Airflow inside the room or building is very important. Keep all supply registers open and all returns free and unrestricted. Avoid placing objects in areas that will hinder unit airflow. The heating and cooling system is designed to have a certain amount of airflow for proper operation. Therefore, closing off registers, in unused rooms as an example, could reduce airflow below acceptable levels and should not be done without review by your service company who can assess the overall situation and advise you accordingly.
6. Heat pumps, especially air-to-air heat pumps, may have the system (compressor) run continuously at lower outdoor temperatures, and this is normal. The heat pump (compressor) mode is controlled by the beginning stages of the thermostat and delivers the most efficient heat. As the outdoor temperature drops off, the heat pump mode heat will also diminish (because there is less heat in the outdoor air to absorb) and must be supplemented by additional electric heat stages, which are not as efficient as the heat pump. The thermostat automatically controls everything and the backup heat will only operate on demand as needed to maintain the desired temperature.
7. The thermostat or controller is the user's primary connection to the system so it is very important to have a thorough understanding of how it works and how to use it properly. Have your installer or service company explain and demonstrate proper operation of the controls.
8. Make sure you thoroughly understand how the heating and cooling system itself is intended to operate and what to expect from it. Have your installer or service company explain and demonstrate proper operation of the heating and cooling system.



---

# A2L REFRIGERANT SAFETY, SERVICE AND DECOMMISSIONING MANUAL

---

## Models:

All Bard Models Using R-454B Refrigerant



### IMPORTANT NOTE:

Read this manual carefully before installing, operating or servicing the new air conditioning unit. Make sure to save this manual for future reference.



**CAUTION:**  
Risk of Fire

Refrigerant  
Safety Group  
A2L



Bard Manufacturing Company, Inc.  
Bryan, Ohio 43506  
[www.bardhvac.com](http://www.bardhvac.com)

Manual: 2100-810  
Supersedes: **NEW**  
Date: 10-16-24

# CONTENTS

---

<b>Safety Precautions .....</b>	<b>3</b>
<b>Servicing Safety Information.....</b>	<b>11</b>
Explanation of Symbols Displayed on the Unit.....	14
<b>Refrigerant Leak Detection System (RDS) .....</b>	<b>15</b>
<b>Servicing Procedures .....</b>	<b>16</b>
Recovery Equipment Rated for R-454B Refrigerant.....	16
Leak Detectors .....	16
Gauge Manifold .....	16
Attaching Gauge Manifold .....	16
Leak Test .....	16
Evacuation.....	17
R-454B System Charging.....	17
Preliminary Charging Steps.....	18
Charging the System by Weight.....	18
EEV Instructions for Recovering, Evacuating and Charging the Unit.....	18
<b>Troubleshooting the Mechanical System.....</b>	<b>24</b>
Air Conditioning and Heat Pump – Cooling .....	24
Low Suction – Low Head Pressure .....	24
High Suction – Low Head Pressure .....	24
Low Suction – High Head Pressure .....	24
High Suction – High Head Pressure .....	24
Heat Pump – Heating .....	24
Low Suction – Low Head Pressure .....	24
High Suction – Low Head Pressure .....	24
Low Suction – High Head Pressure .....	24
High Suction – High Head Pressure .....	24
Troubleshooting Chart for Air Conditioners.....	25
Troubleshooting Chart for Heat Pumps .....	26

## Figures

Figure 1	Release Height, Release Offset and Installed Height in Common Bard Unit Installations.....	5
Figure 2	Electronic Expansion Valve (EEV) and Service Tool.....	18
Figure 3	Typical Air Conditioning System Cooling Cycle .....	19
Figure 4	Typical Heat Pump System Cooling Cycle .....	20
Figure 5	Heating Cycle .....	21
Figure 6	Air Conditioning Mode Circuit Diagram...	22
Figure 7	Dehumidification Mode Circuit Diagram ...	23

## Tables

Table 1A	Maximum Allowable Charge in Kilograms..	6
Table 1B	Maximum Allowable Charge in Ounces .....	6
Table 2A	Minimum Room Area in m <sup>2</sup> .....	7
Table 2B	Minimum Room Area in ft <sup>2</sup> .....	7
Table 3A	Minimum Airflow in m <sup>3</sup> /h .....	8
Table 3B	Minimum Airflow in CFM .....	8
Table 4A	Maximum Charge in Kilograms .....	8
Table 4B	Maximum Charge in Ounces.....	8
Table 5A	Minimum Total Room Area in m <sup>2</sup> .....	9
Table 5B	Minimum Total Room Area in ft <sup>2</sup> .....	9
Table 6A	Example Altitude Adjustment Factors (AF) and Use Example (m) .....	10
Table 6B	Example Altitude Adjustment Factors (AF) and Use Example (ft).....	10

The design and specifications are subject to change without prior notice for product improvement. Consult with the sales agency or manufacturer for details. Any updates to the manual will be uploaded to the Bard website, please check for the latest version.

## **WARNING**

***Read safety precautions before operation and installation.***

***Incorrect installation due to ignoring instructions can cause serious damage or injury.***

The section below provides requirements, warnings, and information regarding best practices for safe and proper installation, service and storage of Bard R-454B equipment. Please adhere to all requirements and recommendations.

### 1. Installation

- Bard wall mount air conditioners are classified as SPVUs (single package vertical units). All refrigerant piping is contained within the unit and all units are shipped with a factory refrigerant charge. No field joints are required for installation. However, care should be taken not to damage pipe work during installation.
- In cases where the installation space requires mechanical ventilation, ensure that ventilation openings are kept clear of obstructions.

### 2. Servicing

- Any person who is involved with working on a unit or breaking into a refrigerant circuit should hold a current valid certificate from an industry-accredited assessment authority, which authorizes their competence to handle refrigerants safely in accordance with an industry recognized assessment specification. Certification examples include: EPA 608 Certification and/or ACCA A2L Training and Certification classes.
- Examples for such working procedures are:
  - Breaking into the refrigerating circuit
  - Opening of sealed components
  - Opening of ventilated enclosures

### 3. Maintenance and repair requiring the assistance of other skilled personnel shall be carried out under the supervision of the person competent in the use of flammable refrigerants.

### 4. Do not use means to accelerate the defrosting process or to clean, other than those recommended by Bard. See most recent version of User's Guide 2100-034 for more information.

5. The appliance shall be stored in a room without continuously operating ignition sources (for example: Open flames, an operating gas appliance or an operating electric heater).
6. Be careful that foreign matter (oil, water, etc) does not enter the piping. Also, when storing piping or components for service replacement, securely seal all openings by pinching, taping, etc.
7. Do not pierce or burn copper or refrigerant-containing components.
8. Be aware that refrigerants may not contain an odor.
9. Work procedures shall only be carried out by competent persons.
10. Appliance shall be stored in well-ventilated area where room size corresponds to the room area as specified for operation. Appliances stored in unventilated areas shall comply with the information found on page 9.
11. The appliance shall be stored so as to prevent mechanical damage from occurring.
12. All field joints shall be tested with detection equipment with a capability of 5 g/year of refrigerant or better, with the equipment in standstill and under operation or under a pressure of at least these standstill or operation conditions after installation. Detachable joints shall NOT be used in the indoor side of the unit (brazed, welded joint could be used).
13. When a FLAMMABLE REFRIGERANT is used, the requirements for installation space of appliance and/or ventilation requirements are determined according to:
  - The mass charge amount ( $M_c$ ) used in the appliance
  - The installation location
  - The type of ventilation of the location or of the appliance

The maximum charge in a room shall be in accordance with the following:

- $M_{max} = 0.5 \times LFL \times h_0 \times A$

or the required minimum floor area  $A_{min}$  to install an appliance with refrigerant charge  $M_c$  (kg) shall be in accordance with:

- $A_{min} = M_c / (0.5 \times LFL \times h_0)$

Where

$M_{max}$  is the allowable maximum charge in a room, in kg

$M_c$  is the refrigerant charge amount in appliance, in kg

$A_{min}$  is the required minimum room area, in  $m^2$

A is the room area, in  $m^2$

LFL is the lower flammable limit, in  $kg/m^3$ . For R-454B at worst case formulation, this value is  $0.296 kg/m^3$ .

$h_0$  is the release height, the vertical distance in meters from the floor to the lowest point of release when the appliance is installed.

$h_0 = (h_{inst} + h_{rel})$  or 0.6m, whichever is higher

$h_{rel}$  is the release offset in meters from the bottom of the appliance to the point of the release

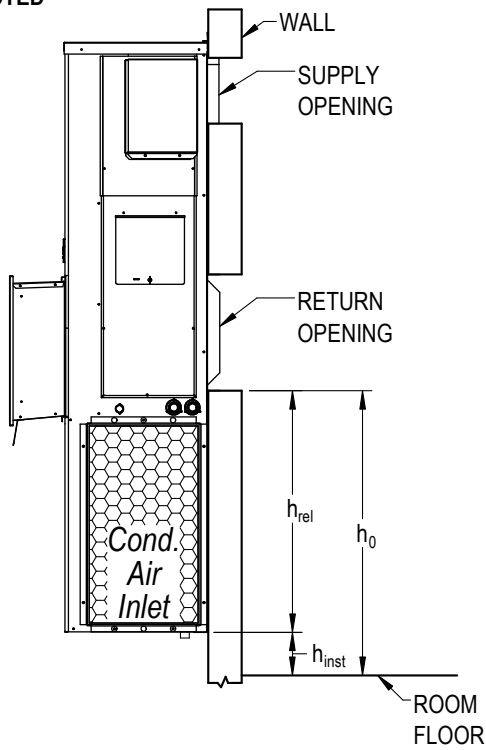
$h_{inst}$  is the installed height in meters of the unit

For appliances serving one or more rooms with an air duct system, the lowest opening of the duct connection to each conditioned space or any opening of the indoor unit greater than  $5 cm^2$ , at the lowest position to the space, shall be used for  $h_0$ . However,  $h_0$  shall not be less than 0.6 m.  $A_{min}$  shall be calculated as a function of the opening. See Figure 1 for examples of  $h_0$ ,  $h_{rel}$  and  $h_{inst}$  as applied to common installations of Bard units.

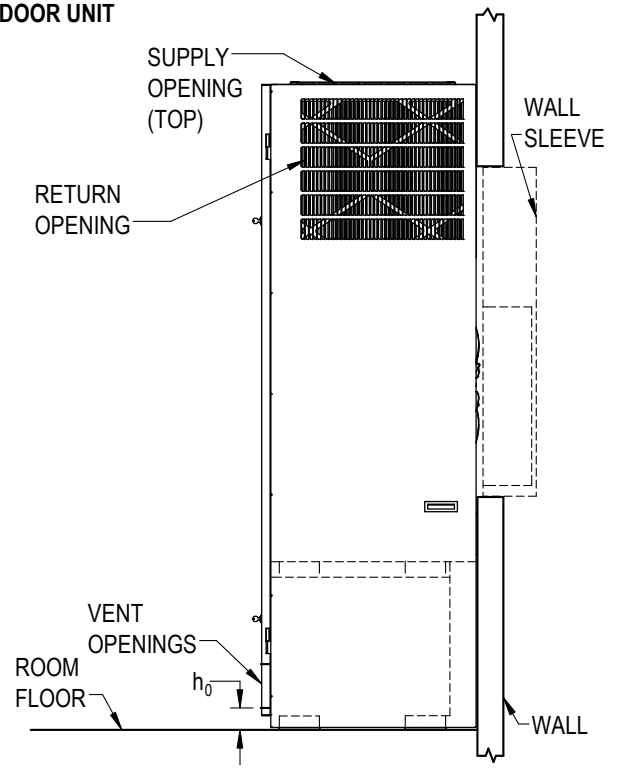
**NOTE:** The unit charge ( $M_c$ ) is listed on the unit serial plate. This can be used to calculate  $A_{min}$ .

**FIGURE 1**  
**Release Height, Release Offset and Installed Height in Common Installations of Bard Units**

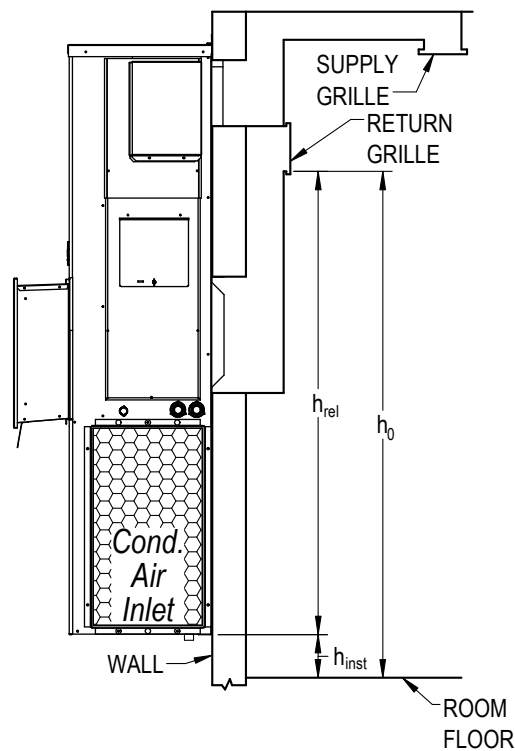
**BARD WALL MOUNT  
 OUTDOOR UNIT-  
 NON-DUCTED**



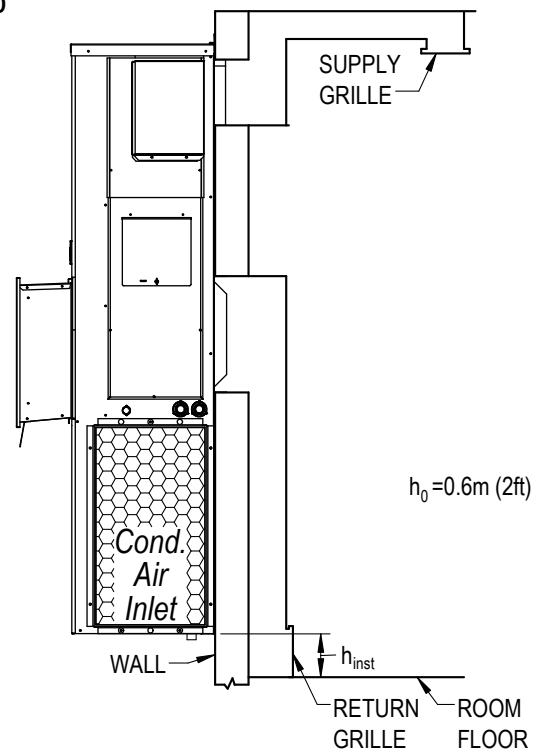
**BARD I-TEC  
 INDOOR UNIT**



**BARD WALL MOUNT  
 OUTDOOR UNIT-  
 DUCTED**



**BARD WALL MOUNT  
 OUTDOOR UNIT-  
 DUCTED**



MIS-4523

**TABLE 1A**  
**Maximum Allowable Charge ( $M_{max}$ ) in Kilograms**

Release Height $h_0$ (m)	Room Area (m <sup>2</sup> )									
	10	20	30	40	50	60	70	80	90	100
0.6	1	2	3	4	4	5	6	7	8	9
1.0	1	3	4	6	7	9	10	12	13	15
1.5	2	4	7	9	11	13	16	18	20	22
2.0	3	6	9	12	15	18	21	24	27	30
2.5	4	7	11	15	19	22	26	30	33	37
3.0	4	9	13	18	22	27	31	36	40	44

**NOTE:** Values are based on a non-ventilated room at sea level.

**TABLE 1B**  
**Maximum Allowable Charge ( $M_{max}$ ) in Ounces**

Release Height $h_0$ (ft)	Room Area (ft <sup>2</sup> )									
	100	200	300	400	500	600	700	800	900	1000
2	30	59	89	118	148	177	207	237	266	296
3	44	89	133	177	222	266	310	355	399	443
4	59	118	177	237	296	355	414	473	532	591
5	74	148	222	296	370	443	517	591	665	739
6	89	177	266	355	443	532	621	710	798	887
7	103	207	310	414	517	621	724	828	931	1035
8	118	237	355	473	591	710	828	946	1064	1183
9	133	266	399	532	665	798	931	1064	1197	1330
10	148	296	443	591	739	887	1035	1183	1330	1478

**NOTE:** Values are based on a non-ventilated room at sea level.

**TABLE 2A**  
Minimum Room Area ( $A_{min}$ ) in  $m^2$

Release Height $h_0$ (m)	Mc (kg)										
	0.5	1.0	1.5	2.0	2.5	3.0	3.5	4.0	4.5	5.0	5.5
0.6	6	11	17	23	28	34	39	45	51	56	62
1.0	3	7	10	14	17	20	24	27	30	34	37
1.5	2	5	7	9	11	14	16	18	20	23	25
2.0	2	3	5	7	8	10	12	14	15	17	19
2.5	1	3	4	5	7	8	9	11	12	14	15
3.0	1	2	3	5	6	7	8	9	10	11	12

**NOTE:** Values are based on a non-ventilated room at sea level.

**TABLE 2B**  
Minimum Room Area ( $A_{min}$ ) in  $ft^2$

Release Height $h_0$ (ft)	Mc (oz)									
	40	60	80	100	120	140	160	180	200	
2	135	203	271	338	406	474	541	609	676	
3	90	135	180	225	271	316	361	406	451	
4	68	101	135	169	203	237	271	304	338	
5	54	81	108	135	162	189	216	244	271	
6	45	68	90	113	135	158	180	203	225	
7	39	58	77	97	116	135	155	174	193	
8	34	51	68	85	101	118	135	152	169	
9	30	45	60	75	90	105	120	135	150	
10	27	41	54	68	81	95	108	122	135	

**NOTE:** Values are based on a non-ventilated room at sea level.

In cases where appliances are connected to one or more rooms via an air duct system and directly ducted to the space,  $M_{max}$  may be reduced or  $A_{min}$  may be increased. In these cases,  $M_{max}$  shall be determined based on the total area of the conditioned space (TA) connected by ducts, taking into consideration that the circulation airflow distributed to all the rooms by the appliance's integral indoor fan will mix and dilute the leaking refrigerant before entering any room. Note that in spaces where the airflow may be limited by zoning dampers, the Refrigerant Leak Detection

System (RDS) shall open the zoning dampers when in alarm state (see unit installation manual for RDS alarm output connection information).

For appliances connected to one or more rooms via an air duct system, the minimum airflow for compliance may be determined using the equation below. See Tables 3A and 3B for reference values.

$$Q_{min} = 30 \times M_c / LFL$$

Where  $Q_{min}$  is the minimum circulation airflow circulated to the total conditioned space in  $m^3/h$ .

**TABLE 3A**  
Minimum Airflow ( $Q_{min}$ ) in  $m^3/h$

Mc (kg)	$Q_{min}$ ( $m^3/h$ )										
	0.5	1.0	1.5	2.0	2.5	3.0	3.5	4.0	4.5	5.0	5.5
	51	101	152	203	253	304	355	405	456	507	557

**TABLE 3B**  
Minimum Airflow ( $Q_{min}$ ) in CFM

Mc (oz)	$Q_{min}$ (cfm)									
	40	60	80	100	120	140	160	180	200	
	68	101	135	169	203	237	271	304	338	

The maximum refrigerant charge for compliance based on the room area for the total conditioned space can be calculated using the equation below. See Tables 4A and 4B for reference values.

$$M_{max} = CF \times LFL \times H \times TA$$

Where

$M_{max}$  is the maximum allowable refrigerant charge in the system in kg

CF is the concentration factor with a value of 0.50

H is the height of the room = 2.2 m.

**TABLE 4A**  
Maximum Charge ( $M_{max}$ ) in Kilograms

TA ( $m^2$ )	$M_{max}$ (kg)									
	20	40	60	80	100	120	140	160	180	200
	6.5	13.0	19.5	26.0	32.6	39.1	45.6	52.1	58.6	65.1

**TABLE 4B**  
Maximum Charge ( $M_{max}$ ) in Ounces

TA ( $ft^2$ )	$M_{max}$ (oz)									
	100	200	300	400	500	600	700	800	900	1000
	3.0	65.1	97.7	130.2	162.8	195.4	227.9	260.5	293.0	325.6

The minimum total conditioned room area for compliance based on the refrigerant charge may be calculated using the following equation. See Tables 5A and 5B for reference values.

$$TA_{\min} = M_c / (CF \times LFL \times H)$$

Where  $TA_{\min}$  is the required minimum area of the total conditioned space in  $m^2$ .

**TABLE 5A**  
Minimum Total Room Area ( $TA_{\min}$ ) in  $m^2$

Mc (kg)	$TA_{\min}$ ( $m^2$ )										
	0.5	1.0	1.5	2.0	2.5	3.0	3.5	4.0	4.5	5.0	5.5
	2	3	5	6	8	9	11	12	14	15	17

**TABLE 5B**  
Minimum Total Room Area ( $TA_{\min}$ ) in  $ft^2$

Mc (oz)	$TA_{\min}$ ( $ft^2$ )									
	40	60	80	100	120	140	160	180	200	
	37	56	75	94	112	131	150	169	187	

#### Altitude Adjustment

Once  $A_{\min}$ ,  $TA_{\min}$  or  $M_c$  has been determined using the methods above, it must be corrected for the final installation site altitude using an Altitude Adjustment Factor (AF). To correct  $A_{\min}$ ,  $TA_{\min}$  or  $M_c$  based on a building site's altitude, multiply the calculated area or refrigerant charge by the AF. The AF accounts for reduced air density at higher altitudes. The formula for adjusting the minimum room area is:

$$\text{Adjusted Area} = \text{Original Area} \times \text{AF}$$

In the same way, the formula for adjusting the maximum charge is:

$$\text{Adjusted Maximum Charge} = \text{Original Maximum Charge} \times \text{AF}$$

The AF depends on the specific appliance type and the altitude ( $H_{\text{alt}}$ ) where it will be installed. The formula for calculating AF is:

$$AF = \frac{P_{\text{sea}}}{P_{\text{site}}}$$

where:

$P_{\text{site}}$  is the atmospheric pressure at the installation site

$P_{\text{sea}}$  level is the standard atmospheric pressure at sea level (usually around 101325 Pa/14.7 psi)

Air pressure above sea level can be calculated as:

$$P_{\text{site}} = 101325 (1 - 2.25577 \cdot 10^{-5} h)^{5.25588}$$

where

101325 = normal temperature and pressure at sea level (Pa)

$P_{\text{site}}$  = air pressure (Pa)

$h$  = altitude above sea level (m)

**NOTE:**  $P_{\text{site}}$  calculation must be done using SI units as shown. The calculated AF can then be applied to any area units.

See Tables 6A and 6B on page 10 for reference values.

#### Ventilation of the Conditioned Space

For installations where  $M_c > M_{\text{max}}$  for the area of the room, compliance can be achieved with the addition of either natural or mechanical ventilation of the conditioned space. See UL60335-2-40, Annex GG for additional paths to compliance.

#### 14. Unventilated Areas

For units containing more than 62.6 oz (1.775 kg) of R454B refrigerant for any refrigerating circuit, an unventilated area where the appliance is installed shall be so constructed that should any refrigerant leak, it will not stagnate so as to create a fire or explosion hazard.

For units installed in a room with an area less than  $A_{\min}$  (see tables 2A and 2B on page 7), but connected via an air duct system to one or more rooms, that room shall be without continuously

**TABLE 6A**  
**Example Altitude Adjustment Factors (AF) and Use Example (m)**

Site Altitude Above Sea Level (m)	Site Pressure (Pa/PSI)	AF	A <sub>min</sub> (m <sup>2</sup> )					
			50	100	150	200	250	300
0	101325.0/14.7	1.000	50	100	150	200	250	300
1000	89874.6/13.0	0.887	44.3	88.7	133.0	177.4	221.7	266.1
2000	79495.2/11.5	0.785	39.2	78.5	117.7	156.9	196.1	235.4
3000	70108.5/10.2	0.692	34.6	69.2	103.8	138.4	173.0	207.6
4000	61640.2/8.9	0.608	30.4	60.8	91.3	121.7	152.1	182.5
5000	54019.9/7.8	0.533	26.7	53.3	80.0	106.6	133.3	159.9
6000	47181.0/6.8	0.466	23.3	46.6	69.8	93.1	116.4	139.7

**TABLE 6B**  
**Example Altitude Adjustment Factors (AF) and Use Example (ft)**

Site Altitude Above Sea Level (ft)	Site Pressure (Pa/PSI)	AF	A <sub>min</sub> (ft <sup>2</sup> )					
			50	100	150	200	250	300
0	101325.0/14.7	1.000	50	100	150	200	250	300
1000	97716.7/14.2	0.964	48.2	96.4	144.7	192.9	241.1	289.3
2000	94213.2/13.7	0.930	46.5	93.0	139.5	186.0	232.5	278.9
3000	90812.1/13.2	0.896	44.8	89.6	134.4	179.2	224.1	268.9
4000	87511.2/12.7	0.864	43.2	86.4	129.6	172.7	215.9	259.1
5000	84308.0/12.2	0.832	41.6	83.2	124.8	166.4	208.0	249.6
6000	81200.5/11.8	0.801	40.1	80.1	120.2	160.3	200.3	240.4

operating open flames (i.e., an operating gas appliance) or other potential ignition sources (e.g., an operating electric heater, hot surfaces). A flame-producing device may be installed in the same space if the device is provided with an effective flame arrest.

For units connected via an air duct system to one or more rooms, auxiliary devices which may be a potential ignition source shall not be installed in the duct work. Examples of such potential ignition sources are hot surfaces with a temperature exceeding 700°C and electric switching devices. Only auxiliary devices approved by Bard or declared suitable with R-454B refrigerant shall be installed in connecting ductwork.

For duct connected units, false ceilings or drop ceilings may be used as a return air plenum if a refrigerant detection system (RDS) is provided in the appliance and any external connections are

also provided with a sensor immediately below the return air plenum duct joint. All Bard products containing R-454B refrigerant come with a factory-installed RDS in the appliance. However, any external sensors required for compliance such as those in this example must be field supplied.

For non-duct connected units with the supply and return air openings in the conditioned space, the body of the appliance may be installed in open areas such as false ceilings not being used as return air plenums, as long as the conditioned air does not directly communicate with the air of the false ceiling.

---

# SERVICING SAFETY INFORMATION

## 1. Checks to the Area

Prior to beginning work on systems containing flammable refrigerants, safety checks are necessary to ensure that the risk of ignition is minimized. For repair to the refrigerating system, the following precautions (items 2-9) shall be complied with prior to conducting work on the system.

## 2. Work Procedure

Work shall be undertaken under a controlled procedure so as to minimize the risk of a flammable gas or vapor being present while the work is being performed.

Technical personnel in charge of operation, supervision, maintenance of air-conditioning systems shall be adequately instructed and competent with respect to their tasks.

Works shall be undertaken with appropriate tools only. (In case of uncertainty, please consult the manufacturer of the tools for use with flammable refrigerants.)

## 3. General Work Area

All maintenance staff and others working in the local area shall be instructed on the nature of work being carried out. Work in confined spaces shall be avoided. The area around the work space shall be sectioned off. Ensure that the conditions within the area have been made safe by control of flammable material.

## 4. Checking for Presence of Refrigerant

The area shall be checked with an appropriate refrigerant detector prior to and during work, to ensure the technician is aware of potentially flammable atmospheres. Ensure that the leak detection equipment being used is suitable for use with flammable refrigerants, e.g., no sparking, adequately sealed or intrinsically safe.

## 5. Presence of Fire Extinguisher

If any hot work is to be conducted on the refrigeration equipment or any associated parts, appropriate fire extinguishing equipment shall be available on hand. Have a dry power or CO<sub>2</sub> fire extinguisher adjacent to the charging area.

## 6. No Ignition Sources

No person carrying out work in relation to a refrigerating system which involves exposing any pipe work that contains or has contained flammable refrigerant shall use any sources of ignition in such a manner that it may lead to the risk of fire or explosion. All possible ignition sources, including cigarette smoking, should

be kept sufficiently far away from the site of installation, repairing, removing and disposal, during which flammable refrigerant can possibly be released to the surrounding space. Prior to work taking place, the area around the equipment is to be surveyed to make sure that there are no flammable hazards or ignition risks. NO SMOKING signs shall be displayed.

## 7. Ventilated Area

Ensure that the area is in the open or that it is adequately ventilated before breaking into the system or conducting any hot work. A degree of ventilation shall continue during the period that the work is carried out. The ventilation should safely disperse any released refrigerant and preferably expel it externally into the atmosphere.

## 8. Checks to the Refrigeration Equipment

Where electrical components are being changed, they shall be fit for the purpose and to the correct specification. At all times, the manufacturer's maintenance and service guidelines shall be followed. If in doubt, consult the manufacturer's technical department for assistance. The following checks shall be applied to installations using flammable refrigerants:

- The refrigerant charge size is in accordance with the room size within which the refrigerant containing parts are installed.
- The ventilation machinery and outlets are operating adequately and are not obstructed;
- If an indirect refrigerating circuit is being used, the secondary circuits shall be checked for the presence of refrigerant.
- Marking to the equipment continues to be visible and legible marking and signs that are illegible shall be corrected.
- Refrigeration pipe or components are installed in a position where they are unlikely to be exposed to any substance which may corrode refrigerant containing components, unless the components are constructed of materials which are inherently resistant to being corroded or are suitably protected against being so corroded.

## 9. Checks to Electrical Devices

Repair and maintenance to electrical components shall include initial safety checks and component inspection procedures. If a fault exists that could compromise safety, then no electrical supply shall be connected to the circuit until it is satisfactorily dealt with. If the fault cannot be corrected

immediately but it is necessary to continue operation, an adequate temporary solution shall be used. This shall be reported to the owner of the equipment so all parties are advised.

Initial safety checks shall include:

- That capacitors are discharged: This shall be done in a safe manner to avoid possibility of sparking.
- That no live electrical components and wiring are exposed while charging, recovering or purging the system.
- That there is continuity of earth bonding.

#### 10. Repairs to Sealed Components

Sealed electrical components shall be replaced.

#### 11. Repair to Intrinsically Safe Components

Intrinsically safe components must be replaced.

#### 12. Cabling

During installation, check that field wiring and cabling will not be subject to wear, corrosion, excessive pressure, vibration, sharp edges or any other adverse environmental effects. The check shall also take into account the effects of aging or continual vibration from sources such as compressors or fans.

#### 13. Detection of Flammable Refrigerants

Under no circumstances shall potential sources of ignition be used in the searching for or detection of refrigerant leaks. A halide torch (or any other detector using a naked flame) shall not be used.

#### 14. Leak Detection Methods

The following leak detection methods are deemed acceptable for systems containing flammable refrigerants. Electronic leak detectors may be used to detect refrigerant leaks but, in the case of flammable refrigerants, the sensitivity may not be adequate, or may need re-calibration. (Detection equipment shall be calibrated in a refrigerant-free area.) Ensure that the detector is not a potential source of ignition and is suitable for R-454B refrigerant. Leak detection equipment shall be set at a percentage of the lower flammable limit (LFL) of the refrigerant and shall be calibrated for R-454B and the appropriate percentage of gas (25% maximum) is confirmed. Leak detection fluids are suitable for use with most refrigerants but the use of detergents containing chlorine shall be avoided as the chlorine may react with the refrigerant and corrode the copper pipe-work.

**NOTE:** Examples of leak detection fluids are:

- Bubble method
- Fluorescent method agents

If a leak is suspected, all naked flames shall be removed or extinguished.

If a leakage of refrigerant is found which requires brazing, all of the refrigerant shall be recovered from the system. In accordance with industry-standard practice, oxygen-free nitrogen (OFN) shall then be purged through the system both before and during the brazing process.

#### 15. Removal and Evacuation

When breaking into the refrigerant circuit to make repairs—or for any other purpose—conventional procedures shall be used. However, for flammable refrigerants it is important that best practice be followed, since flammability is a consideration. The following procedure shall be adhered to:

- Safely remove refrigerant following local and national regulations
- Evacuate
- Purge the circuit with oxygen-free nitrogen
- Evacuate
- Continuously flush or purge with oxygen-free nitrogen when using flame to open circuit
- Open the circuit

The refrigerant charge shall be recovered into the correct recovery cylinders if venting is not allowed by local and national codes. For appliances containing flammable refrigerants, the system shall be purged with oxygen-free nitrogen to render the appliance safe for flammable refrigerants. This process might need to be repeated several times. Compressed air or oxygen shall not be used for purging refrigerant systems.

For appliances containing flammable refrigerants, refrigerants purging shall be achieved by breaking the vacuum in the system with oxygen-free nitrogen and continuing to fill until the working pressure is achieved, then venting to atmosphere, and finally pulling down to a vacuum. This process shall be repeated until no refrigerant is within the system. When the final oxygen-free nitrogen charge is used, the system shall be vented down to atmospheric pressure to enable work to take place.

The outlet for the vacuum pump shall not be close to any potential ignition sources, and ventilation shall be available.

#### 16. Charging Procedures

In addition to conventional charging procedures, the following requirements shall be followed:

- Work shall be undertaken with appropriate tools only. (In case of uncertainty, please consult the manufacturer of the tools for use with flammable refrigerants.)

- Ensure that contamination of different refrigerants does not occur when using charging equipment. Hoses or lines shall be as short as possible to minimize the amount of refrigerant contained in them.
- Cylinders shall be kept upright.
- Ensure that the refrigeration system is earthed prior to charging the system with refrigerant
- Extreme care shall be taken not to overfill the refrigeration system.
- Prior to recharging the system, it shall be pressure tested with oxygen-free nitrogen.

The system shall be leak tested on completion of charging but prior to commissioning. A follow-up leak test shall be carried out prior to leaving the site.

#### 17. Decommissioning

Before carrying out this procedure, it is essential that the technician is completely familiar with the equipment and all its detail. It is recommended good practice that all refrigerants are recovered safely. Prior to the task being carried out, an oil and refrigerant sample shall be taken in case analysis is required prior to re-use of reclaimed refrigerant. It is essential that electrical power is available before the task is commenced.

- Become familiar with the equipment and its operation.
- Isolate system electrically.
- Before attempting the procedure, ensure that:
  - Mechanical handling equipment is available, if required, for handling refrigerant cylinders.
  - All personal protective equipment is available and being used correctly.
  - The recovery process is supervised at all times by a competent person.
  - Recovery equipment and cylinders conform to the appropriate standards.
- Pump down refrigerant system, if possible.
- In order to pull a complete vacuum, fully reclaim the system or charge the unit, connections to all service ports—suction, liquid and discharge—need to be utilized.
- Make sure that cylinder is situated on the scales before recovery takes place in order to ensure refrigerant charge is weighed in properly.
- Start the recovery machine and operate in accordance with manufacturer's instructions.

- Do not overfill cylinders (no more than 80% volume liquid charge).
- Do not exceed the maximum working pressure of the cylinder, even temporarily.
- When the cylinders have been filled correctly and the process completed, make sure that the cylinders and the equipment are removed from site promptly and all isolation valves on the equipment are closed off.
- Recovered refrigerant shall not be charged into another refrigeration system unless it has been cleaned and checked.

#### 18. Labeling

Equipment shall be labeled stating that it has been de-commissioned and emptied of refrigerant. The label shall be dated and signed. Ensure that there are labels on the equipment stating the equipment contains flammable refrigerant.

#### 19. Recovery

When removing refrigerant from a system, either for service or decommissioning, be sure that all refrigerants are removed safely.

When transferring refrigerant into cylinders, ensure that only appropriate refrigerant recovery cylinders are employed. Ensure that the correct numbers of cylinders for holding the total system charge are available. All cylinders to be used are designated for the recovered refrigerant and labeled for that refrigerant (i.e., special cylinders for the recovery of refrigerant). Cylinders shall be complete with pressure relief valve and associated shut-off valves in good working order.

The recovery equipment shall be in good working order with a set of instructions concerning the equipment that is at hand and shall be suitable for the recovery of the flammable refrigerant. If in doubt, the manufacturer should be consulted. In addition, a set of calibrated weighing scales shall be available and in good working order. Hoses shall be complete with leak-free disconnect couplings and in good condition.

The recovered refrigerant shall be processed according to local legislation in the correct recovery cylinder, and the relevant waste transfer note arranged. Do not mix refrigerants in recovery units and especially not in cylinders.

If compressors or compressor oils are to be removed, ensure that they have been evacuated to an acceptable level to make certain that flammable refrigerant does not remain within the lubricant. The compressor body shall not be heated by an open flame or other ignition sources to accelerate this process. When oil is drained from a system, it shall be carried out safely.

If compressors or compressor oils are to be removed, ensure that they have been evacuated to an acceptable level to make certain that flammable refrigerant does not remain within the lubricant. The compressor body shall not be heated by an open flame or other ignition source to accelerate this process. When oil is drained from a system, it shall be carried out safely.

#### 20. Transport of Equipment Containing Flammable Refrigerants

Additional transportation regulations may exist with respect to equipment containing flammable gas. The maximum number of pieces of equipment or the configuration of the equipment permitted to be transported together will be determined by the applicable transport regulations.

#### 21. Marking of Equipment Using Signs

Signs for similar appliances used in a work area are generally addressed by local regulations and give the minimum requirements for the provision of safety and/or health signs for a work location. All required signs are to be maintained and employers should ensure that employees receive suitable and sufficient instruction and training on the meaning of appropriate safety signs and the actions that need to be taken in connection with these signs. The effectiveness of signs should not be diminished by too many signs being placed together. Any pictograms used should be as simple as possible and contain only essential details.

#### 22. Disposal of Equipment Using Flammable Refrigerants

See national regulations.

#### 23. Storage of Equipment/Appliances

The storage of the appliance should be in accordance with the applicable regulations or instructions provided by Bard, whichever is more stringent.

#### 24. Storage of Packed (Unsold) Equipment

Storage package protection should be constructed in such a way that mechanical damage to the equipment inside the package will not cause a leak of the refrigerant charge. The maximum number of pieces of equipment permitted to be stored together will be determined by local regulations.

## Explanation of Symbols Displayed on the Unit



This symbol indicates that the unit contains a mildly flammable refrigerant.



This symbol indicates that the refrigerant used is classified as an A2L, or mildly flammable refrigerant.



This symbol indicates that the Operation Manual should be read carefully.



This symbol indicates that a service personnel should be handling this equipment with reference to the Installation Manual.



This symbol indicates that information is available such as the Operation Manual or Installation Manual.

---

# **REFRIGERANT LEAK DETECTION SYSTEM (RDS)**

For information about the Refrigerant Leak Detection System (RDS), see unit installation manual.

# SERVICING PROCEDURES

## WARNING

*The oils used with R-454B refrigerant are hygroscopic and absorb water from the atmosphere readily. Do not leave systems open to the atmosphere for more than 5 minutes. If the system has been open for more than 5 minutes, change the filter dryer immediately before evacuation. Then recharge the system to the factory-specified charge.*

### Recovery Equipment Rated for R-454B Refrigerant

R-454B has an ozone depletion potential of zero, but must be reclaimed due to its global warming potential.

R-454B refrigerant operates at pressures similar to R-410A. The gauge manifold set must be designed to withstand the higher pressure associated with R-454B. Manifold sets are required to range up to 800 psig on the high side and 250 psig on the low side with a 250 psig low side retard.

All hoses must have a service rating of 800 psig. (This information will be indicated on the hoses.)

Vacuum pump and micron gauge must be used when evacuating a system to 500 microns.

### Leak Detectors

An electronic leak detector rated for use with flammable refrigerants can be used with R-454B refrigerant.

### Gauge Manifold

## WARNING

*Gauge manifold must be suitable for use with R-454B refrigerant and POE oils.*

A necessary instrument in checking and serving air conditioning and heat pump equipment is the gauge manifold. Its purpose is to determine the operating refrigerant pressures in order for the service technician to analyze the condition of the system.

The valving on the manifold is so arranged that when the valves are closed (front-seated) the center port on the manifold is closed to the gauges and gauge ports.

With the valves in the closed position, the gauge ports are still open to the gauges, permitting the gauges to register system pressures. Opening either valve opens the center port to that side of the manifold and system.

### Attaching Gauge Manifold

For leak testing, purging, checking charge, charging liquid or evacuating, connect high pressure side of gauge manifold to Schrader valve on liquid or discharge line. Connect suction side of gauge manifold to Schrader valve on suction line. On heat pumps the suction line is between compressor and reversing valve.

## WARNING

*As a safety measure, it is wise to attach refrigerant hoses at the points of lowest pressure in the system. To do this:*

- A. Put high pressure hose "B" on first. (Unit should not be running.)*
- B. Put low pressure hose "A" on second. (Unit should be running.)*

Attaching manifold hose to Schrader valve:

1. Remove cap from valve.
2. Make sure gauge manifold valves are closed.
3. If hose does not have an unseating pin, a number 395 Superior or equivalent unseating coupler must be used.
4. Make sure coupler is lined up straight with Schrader valve. Screw coupler onto valve.
5. Open gauge manifold valve slightly and purge air from hose with refrigerant.
6. Read the suction pressure on compound gauge and heat pressure on pressure gauge.
7. To remove, push end of hose tight against end of Schrader valve and hold in place while quickly unscrewing coupler nut from Schrader valve.
8. Remove coupler from Schrader valve. Replace caps on valve.

### Leak Test

1. If the system still contains refrigerant when a leak is suspected, check all soldered joints and areas of suspicion with an electronic leak detector suitable for use with R-454B refrigerant.

**NOTE:** Older R-22 leak detectors will not detect leaks in R-454B systems.

2. If no leak is found in Step 1, or the total refrigerant charge has leaked out, recover remaining refrigerant from the system and evacuate. (See **Evacuation** section below and unit installation manual for more information.)

**NOTE:** When working on an R-454B system, recovery pumps, vacuum pumps and charging cylinders should be connected to an earth ground at all times during use.

3. Remove gauge port cap from suction and liquid service valve ports and attach manifold gauge hoses. Connect an upright cylinder of oxygen-free dry nitrogen (OFN) to center port of gauge manifold. Open nitrogen cylinder valve and manifold high pressure gauge valve to pressurize system to a positive pressure with OFN vapor. Pressurize the complete system until the pressure reaches 200 psig. Do not exceed 250 psig.
4. Close manifold high pressure gauge valve. Check all soldered joints, including those on the evaporator coil, by spraying with a soap and water solution and looking for bubbles. If a leak is found which requires soldering, pressure in the system must be bled off since it is impossible to solder with unit pressurized. Be sure all leaks are located and marked before bleeding pressure from system.
5. Close OFN tank valve and disconnect from center port. Release nitrogen into the atmosphere through suction line of gauge manifold.
6. Correct any leaks and recheck.
7. Replace filter drier. The liquid line filter dryer (R-454B compatible) must be replaced any time the system is open. When removing a filter dryer from a system, do not use a torch; use a tubing cutter to avoid releasing moisture back into the system.
8. Once filter drier has been replaced, recheck for leaks. When leaks, if any, have been repaired, system is ready to be evacuated and charged. Relieve all pressure from the system down to 0 psig.

**REMEMBER:** Always use a pressure regulator with nitrogen and a safety valve down stream.

## Evacuation

An evacuation to 500 microns is usually sufficient to remove moisture from a system using R-22 and mineral oil lubricant. A 500 micron evacuation, however, will not separate moisture from Polyol Ester oil (POE) in R-454B systems.

1. Evacuate system to less than 500 microns, using a good vacuum pump designed for use with flammable refrigerants and an accurate high vacuum gauge. Operate the pump below 500 microns for 60 minutes and then close valve to

the vacuum pump. Allow the system to stand for 30 additional minutes to be sure a 500 micron vacuum or less is maintained.

## **WARNING**

**Do not use the compressor to evacuate the system or any part of it.**

2. Disconnect charging line at vacuum pump and connect to refrigerant supply. Crack the cylinder valve and purge charging line at center on manifold. Then close cylinder valve.
3. The system is now ready for the correct operating charge of refrigerant R-454B.

## R-454B System Charging

Even though R-454B has a low fractionation potential, it cannot be ignored when charging. For this reason, R-454B systems should never be "topped off". The remaining system charge should always be recovered, the system evacuated, and then charged to the amount shown on the unit serial plate. To avoid fractionation, charging of an air conditioner or heat pump system incorporating R-454B shall be done with "liquid" to maintain optimum system performance. To ensure that the proper blend composition is charged into the system, it is important that liquid only be removed from the charging cylinder.

Some cylinders supplied by manufacturers have dip tubes which allow liquid refrigerant to be removed from the cylinder when it is in the upright position. Cylinders without dip tubes have to be tipped upside down in order for liquid to be removed. The service technician must differentiate between which type of charging cylinder they are using to avoid removing vapor refrigerant instead of liquid refrigerant to avoid fractionation and for safety concerns.

Allow liquid to enter the high side only. The high side will hold 80-100% of the total charge. When liquid stops flowing, close high-side port. The remainder of the charge will be added to the low side. Keep in mind two issues: First, never start the compressor with less than 55 psig of suction pressure. Secondly, make sure the liquid is throttled, thus vaporized into the low side of the system to avoid compressor damage. A throttling valve can be used to ensure that liquid is converted to vapor prior to entering the system. Proper manipulation (restricting) of the manifold gauge set can also act as a throttling device to ensure liquid is not entering the compressor.

For single package units, refer to the unit serial plate for the full operating charge.

### Preliminary Charging Steps

If the system has been open to the atmosphere, the filter dryer should be replaced and then evacuated. Then proceed as follows:

1. Attach a cylinder of proper, clean refrigerant to the center port of the charging manifold with one of the charging hoses.
2. Attach a second charging hose to the suction gauge (low pressure) side of the gauge manifold.
3. Remove the cap from the suction line valve.
4. Loosely attach the suction gauge hose to the line valve. Open the valve on the refrigerant cylinder and the suction valve on the charging manifold slightly to purge the air from the manifold and hoses before tightening the fitting.
5. Attach the third hose to the high pressure side of the manifold and the liquid line valve. Repeat Steps 3 and 4 above.

### Charging the System by Weight

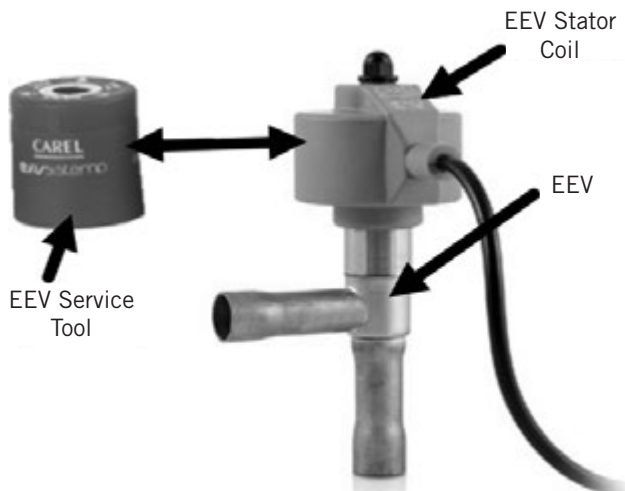
1. Connect manifold as instructed.
2. Place refrigerant cylinder on scale and determine exact weight of the refrigerant and cylinder.
3. With manifold suction valve closed and manifold discharge valve open, open refrigerant cylinder liquid valve and allow pressure in system to balance with pressure of cylinder or 80% of charge is in the unit—whichever comes first.
4. When there is approximately an 80% charge, front seat (close) the discharge manifold valve and let the system stabilize for about five minutes.
5. Start compressor by setting thermostat.
6. Finish charging with liquid by cracking the suction valve. Open the manifold low pressure valve to allow refrigerant to flow into the system. Throttle the manifold valve to keep pressure about 100 psig for R-454B.
7. When the correct weight of refrigerant has been added to the unit, close refrigerant cylinder valve and allow unit to run for 30 minutes. Refer to Start-Up Procedure and Check List for further start-up details.
8. Front seat gauge manifold valves, disconnect charging and gauge hoses and replace all valve caps.

### EEV Instructions for Recovering, Evacuating and Charging the Unit

Some Bard units use an electronic expansion device to meter refrigerant. In these units, the electronic expansion valve moves to a closed position when there is no call to control. In order to pull a complete vacuum, fully recover the system or charge the unit, connections to all service ports—suction, liquid and discharge—need to be utilized or the valve needs to be manually opened first. The valve can be opened manually using the magnetic EEV service tool (Bard Part # 2151-021) shown in Figure 2. To do this, remove the EEV stator coil (red color with retaining nut on top), slide the magnetic tool over the shaft where the stator was removed and turn in a clockwise direction to open the valve to the full open position (directional arrows are provided on the tool).

Reapply the EEV stator coil and retaining nut once complete. Upon powering the unit back up, the control board will automatically drive the EEV back to the fully shut position. Once the compressor starts, the control board will again modulate the EEV position to control the system superheat.

**FIGURE 2**  
**Electronic Expansion Valve (EEV) and Service Tool**



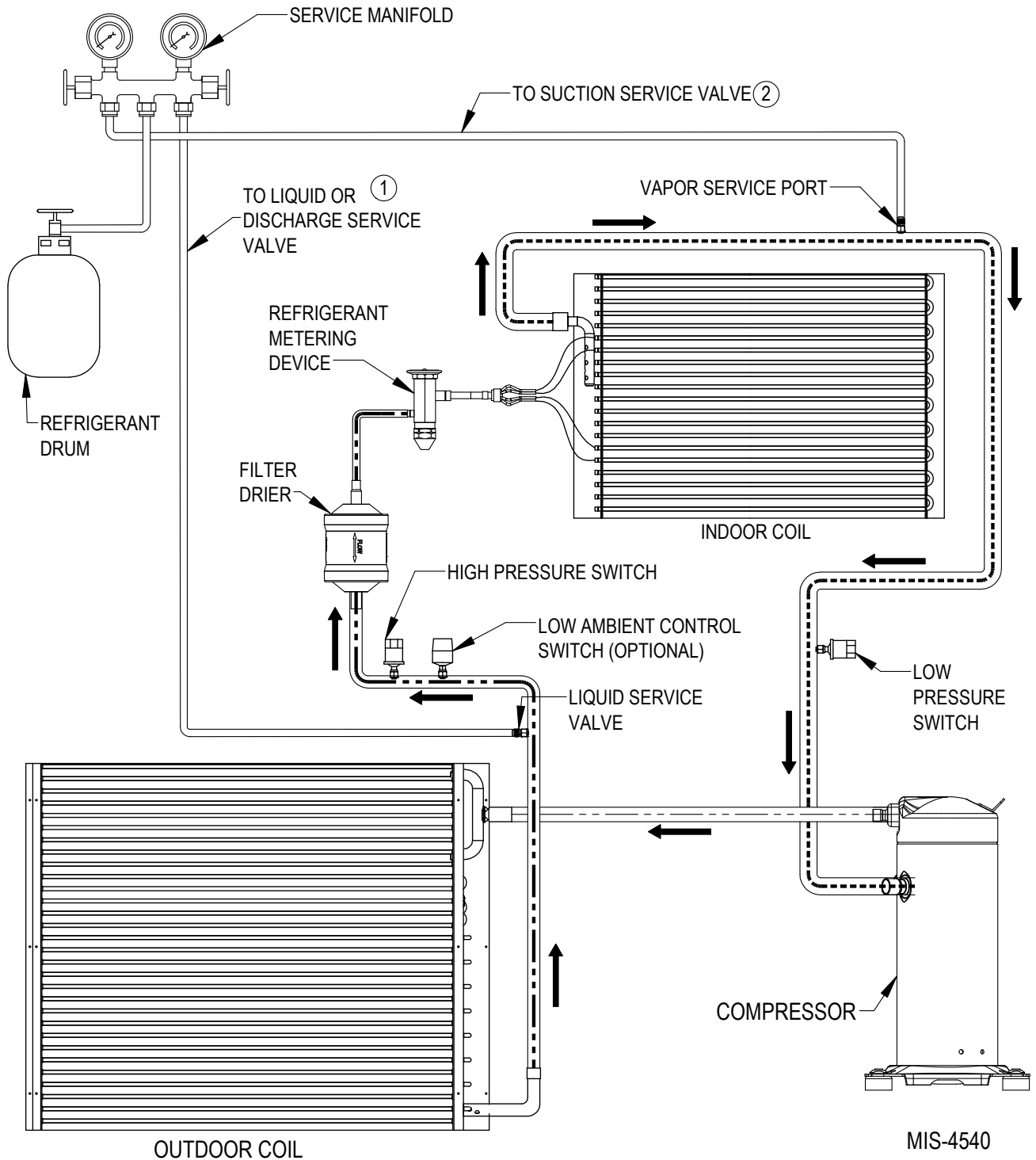
## **⚠ WARNING**

*To speed refrigerant flow, it may be necessary to place refrigerant cylinder in a pan of warm water (not greater than 130°F). Remember to either consider the total weight of the pan of water or remove the cylinder for weighing frequently to keep track of the charging process.*

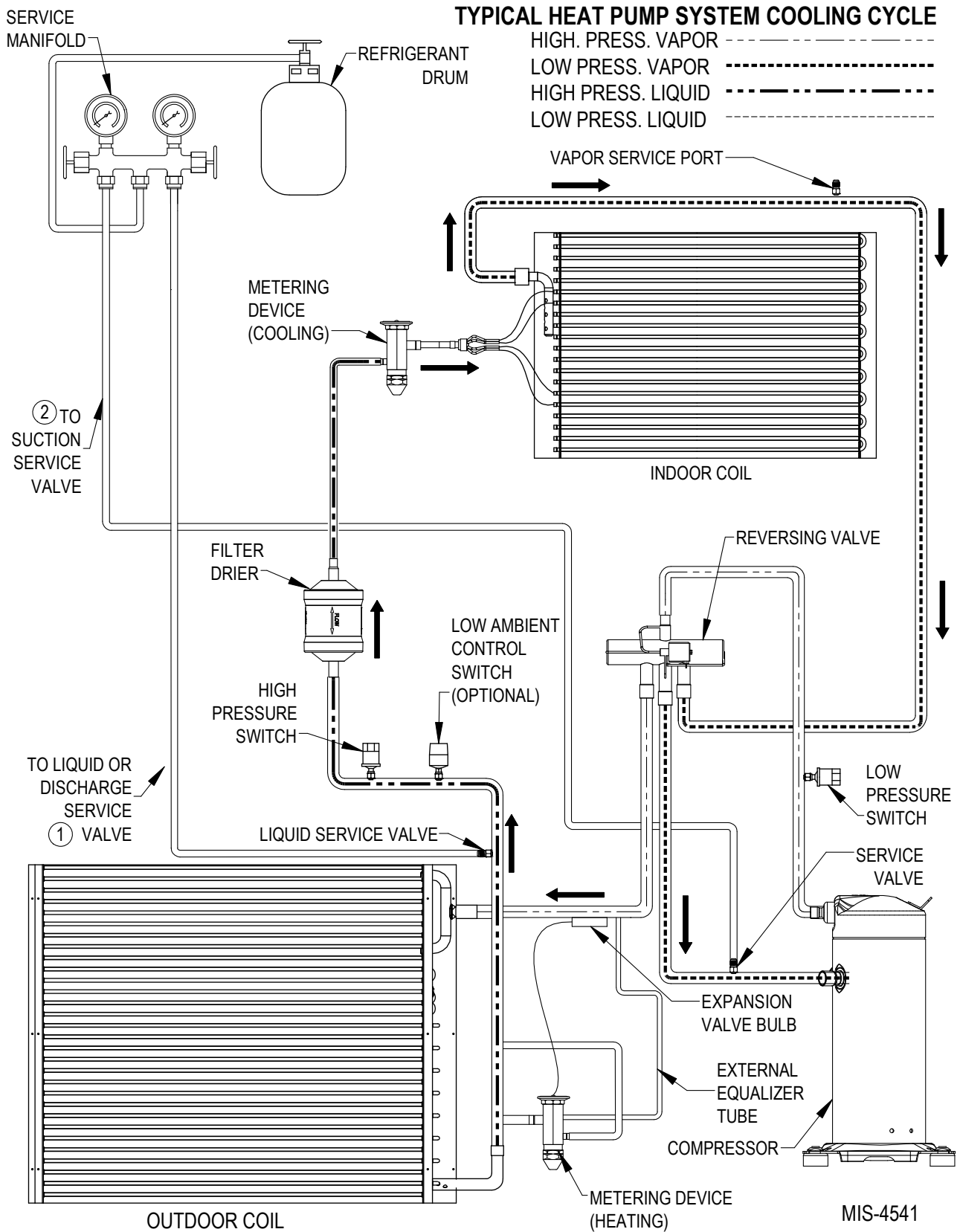
**FIGURE 3**  
**Typical Air Conditioning System Cooling Cycle**

**TYPICAL AIR CONDITIONING SYSTEM COOLING CYCLE**

HIGH. PRESS. VAPOR -----  
 LOW PRESS. VAPOR - - - - -  
 HIGH PRESS. LIQUID - - - - -  
 LOW PRESS. LIQUID -----



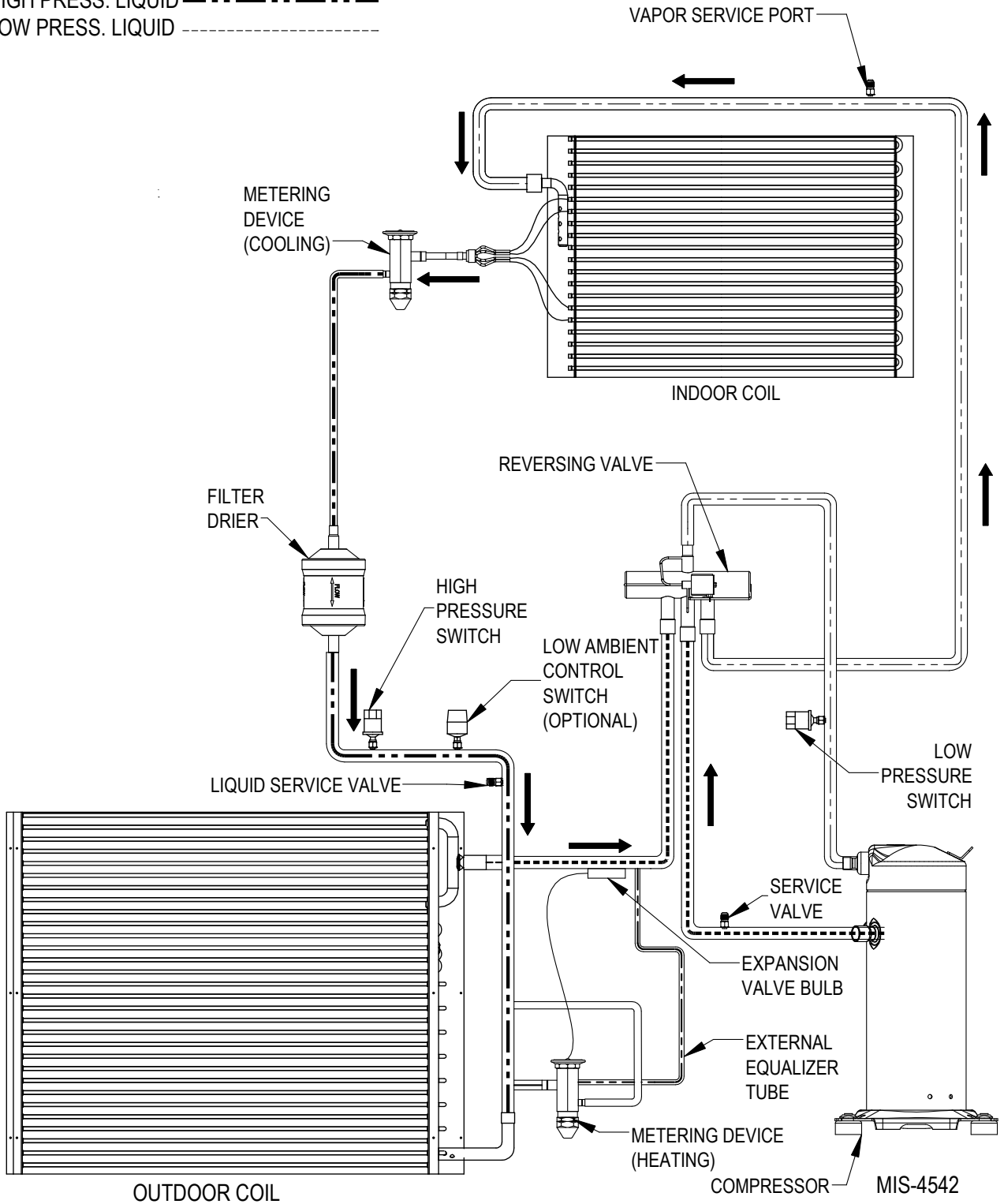
**FIGURE 4**  
**Typical Heat Pump System Cooling Cycle**



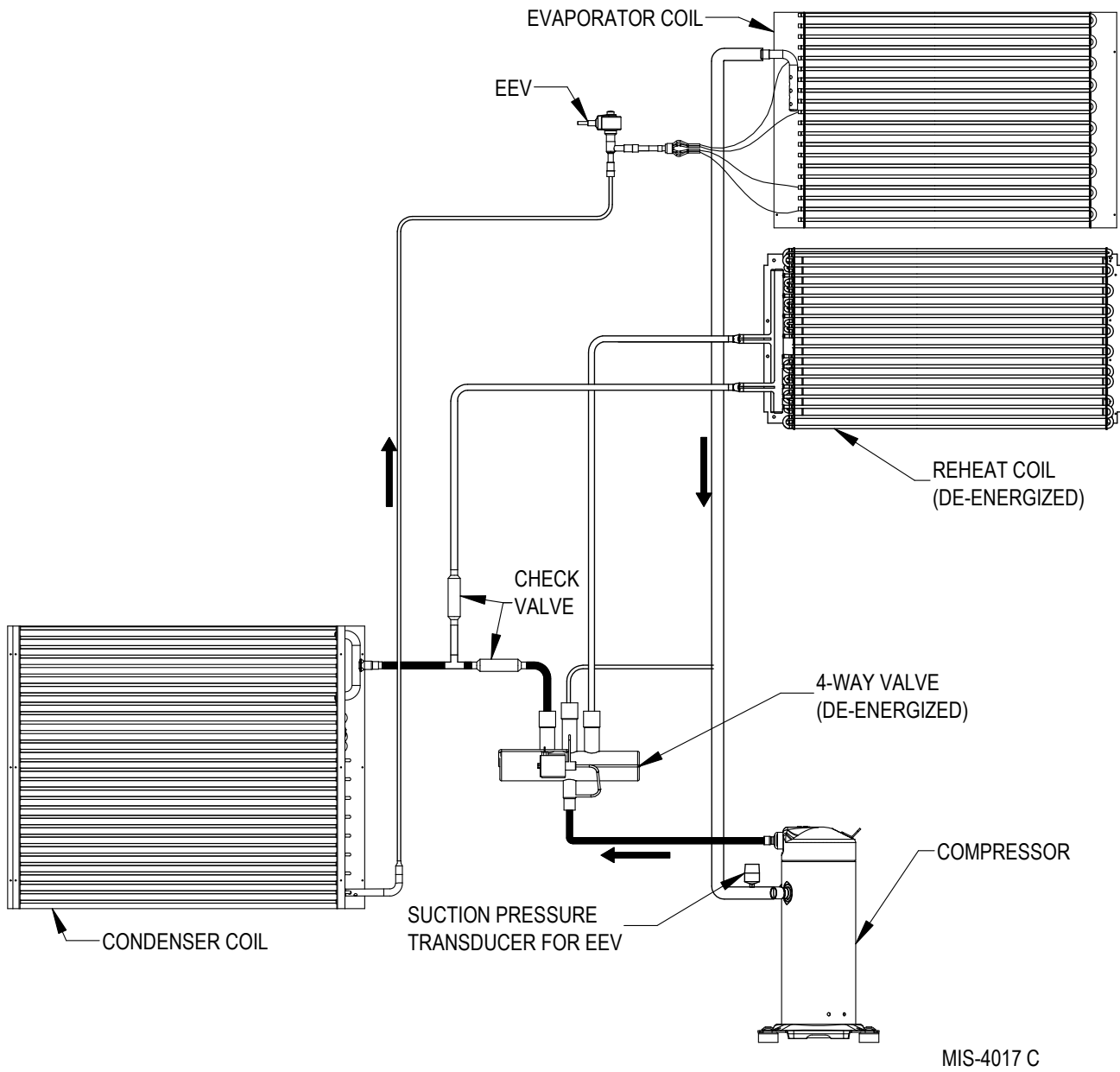
**FIGURE 5**  
Heating Cycle

**TYPICAL HEAT PUMP SYSTEM HEATING CYCLE**

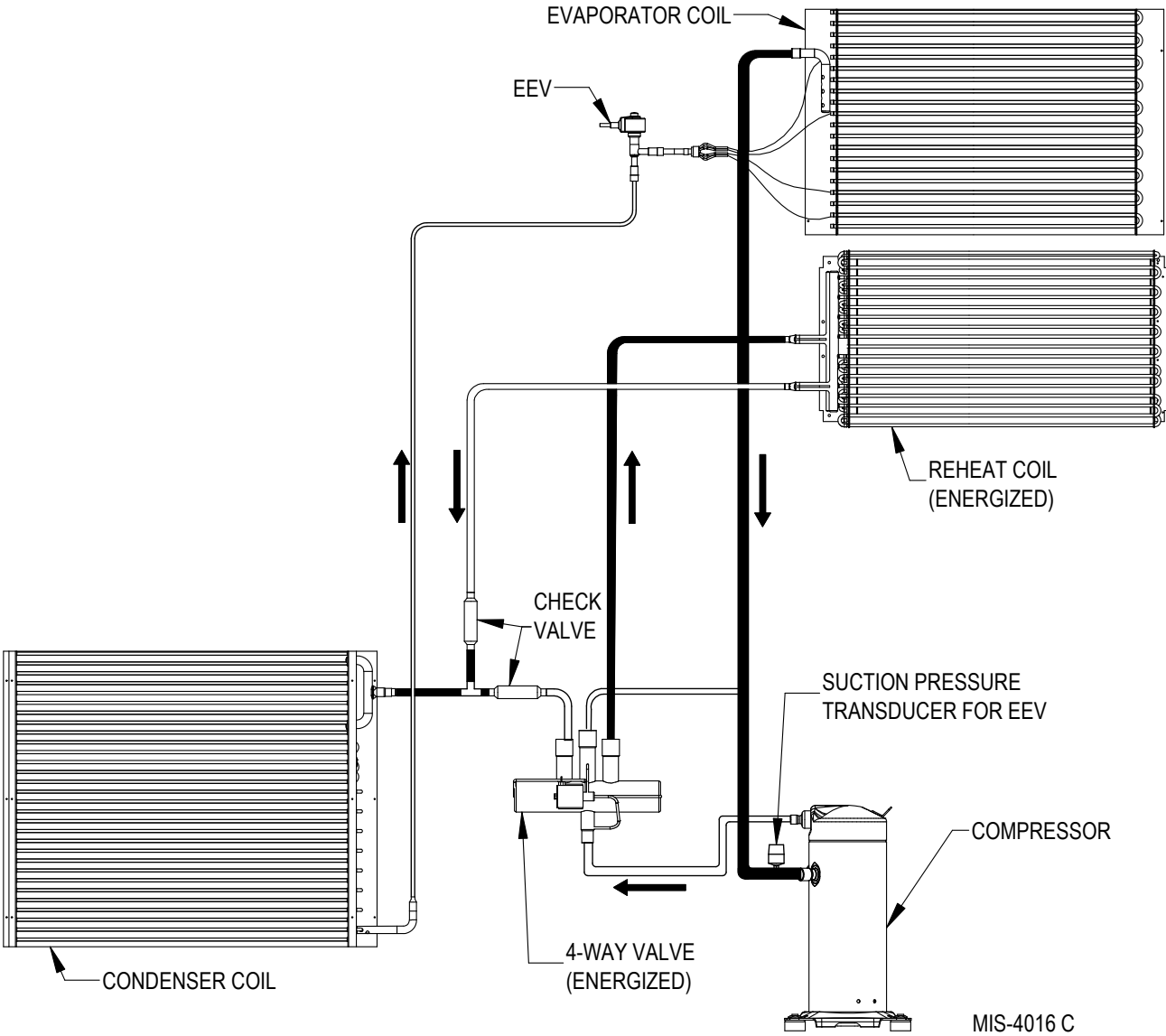
HIGH. PRESS. VAPOR ————  
 LOW PRESS. VAPOR - - - - -  
 HIGH PRESS. LIQUID — — — — —  
 LOW PRESS. LIQUID - - - - -



**FIGURE 6**  
**Air Conditioning Mode Circuit Diagram**



**FIGURE 7**  
**Dehumidification Mode Circuit Diagram**



# **TROUBLESHOOTING THE MECHANICAL SYSTEM**

---

## **Air Conditioning and Heat Pump – Cooling**

### **Low Suction – Low Head Pressure**

1. Restricted airflow over indoor coil
2. Defective indoor fan motor
3. Low indoor temperature
4. Iced indoor coil
5. Restricted liquid line, dryer, metering device, etc.
6. Low charge
7. Low ambient entering air temperature. (Low entering water temperature to water coil.®)

### **High Suction – Low Head Pressure**

1. Defective or broken valves
2. IPRV valve open
3. Defective reversing valve

### **Low Suction – High Head Pressure**

1. Partial restriction and then overcharged

### **High Suction – High Head Pressure**

1. High entering outdoor air temperature. (High entering water temperature.®)
2. Low airflow outdoor coil. (Low water flow.®)
3. Overcharged
4. Air in system
5. Restricted outdoor coil. (Restricted water coil.®)
6. High indoor air temperature

## **Heat Pump – Heating**

### **Low Suction – Low Head Pressure**

1. Restricted airflow through outdoor coil. (Restricted water flow through water coil.®)
2. Defective outdoor motor. (Defective water pump.®)
3. Low outdoor air temperature. (Low water temperature.®)
4. Frozen outdoor coil. (Frozen water coil.®)
5. Restricted liquid line, dryer, metering device, etc.
6. Low charge
7. Low indoor air temperature

### **High Suction – Low Head Pressure**

1. Defective or broken valves
2. IPR valve open
3. Defective reversing valve

### **Low Suction – High Head Pressure**

1. Partial restriction and then overcharged

### **High Suction – High Head Pressure**

1. High entering outdoor air temperature. (High entering water temperature.®)
2. Low indoor airflow
3. Overcharged
4. Air in system
5. Restricted air coil
6. High indoor air temperature

® Water source heat pump

# TROUBLESHOOTING CHART FOR AIR CONDITIONERS

	Power Supply										High Pressure Side of System										Low Side										General																																	
	Meter to Line Side of Contactor					Load Side of Contactor to Motor Terminal					Control Circuit					Motors					Compressor					System Operation					Condenser Air					Evaporator Air					General																							
• Power Failure	• Blown Fuses or Tripped Circuit Breakers	• Faulty Wiring	• Loose Terminals	• Low Voltage	• Single 1PH Failure of 3PH	• Unbalanced Power Supply 3PH	• Voltage Too High	• Open Disconnect Switch	• Faulty Wiring	• Loose Terminal	• Low Voltage	• Defective Contacts in Contactor	• Compressor Overload	• Potential Relay Fails to Open	• Potential Relay Fails to Close	• Run Capacitor	• Start Capacitor	• Faulty Wiring	• Loose Terminals	• Control Transformer	• Low Voltage	• Thermostat	• Contactor Coil	• Pressure Control	• Condenser Fan Relay	• Evaporator Fan Relay	• Compressor Motor	• Condenser Motor	• Evaporator Motor	• Compressor Off on Internal Overload	• Compressor Oil Level	• Hold Down Bolts	• Defective Compressor Valves	• Seized Compressor	• Defective Compressor Bearings	• Open or Short Motor Windings	• Refrigerant Charge Low	• Overcharge of Refrigerant	• High Head Pressure	• High Suction Pressure	• Low Suction Pressure	• Temperatures	• Non-Condensables (Air, etc.)	• Excessive Load in Space	• Liquid Valve Partially Closed	• Condenser Fins Dirty or Plugged	• Condenser Fan Belt Slipping	• Condenser Air Short Circuiting	• Low Condenser Air Volume	• Condenser Air Temperature Low	• Plugged or Restricted Metering Device	• Evaporator Fins Dirty or Plugged	• Evaporator Belt Slipping	• Low Evaporator Air Volume	• Dirty Filters	• Ductwork Small or Restricted	• Restrictions	• Thermostat Setting	• Thermostat Location	• Stratified Air in Space	• Incorrect Refrigerant Piping	• System Too Small		
• Generally the cause. Always make these checks first.	• Occasionally the cause. Make these checks only if first checks fail to locate trouble.	• Rarely the cause. Make this check only if previous checks fail to locate trouble.	• Compressor and condenser fan motor will start but compressor fan will not run	• Condenser fan motor will not start	• Compressor "hums" but will not start	• Compressor cycles on overload	• Compressor short cycles on low pressure	• Compressor runs continuously—no cooling	• Compressor runs continuously—cooling	• Compressor noisy	• Compressor leaks oil	• Head pressure too high	• Head pressure too low	• Liquid line frosting or sweating	• Suction pressure too high	• Suction pressure too low	• Evaporator frosting	• Suction line frosting or sweating	• Evaporator blower will not start	• Condenser fan motor runs but not pulled in	• Liquid refrigerant flooding back to compressor—cap. tube system	• Space temperature too high	• Faulty Wiring	• Loose Terminals	• Low Voltage	• Thermostat	• Contactor Coil	• Pressure Control	• Condenser Fan Relay	• Evaporator Fan Relay	• Compressor Motor	• Condenser Motor	• Evaporator Motor	• Compressor Off on Internal Overload	• Defective Compressor Bearings	• Seized Compressor	• Defective Compressor Valves	• Open or Short Motor Windings	• Refrigerant Charge Low	• Overcharge of Refrigerant	• High Head Pressure	• High Suction Pressure	• Low Suction Pressure	• Temperatures	• Non-Condensables (Air, etc.)	• Excessive Load in Space	• Liquid Valve Partially Closed	• Condenser Fins Dirty or Plugged	• Condenser Fan Belt Slipping	• Condenser Air Short Circuiting	• Low Condenser Air Volume	• Condenser Air Temperature Low	• Plugged or Restricted Metering Device	• Evaporator Fins Dirty or Plugged	• Evaporator Belt Slipping	• Low Evaporator Air Volume	• Dirty Filters	• Ductwork Small or Restricted	• Restrictions	• Thermostat Setting	• Thermostat Location	• Stratified Air in Space	• Incorrect Refrigerant Piping	• System Too Small





---

# INSTALLATION INSTRUCTIONS

---

## R-454B Step Capacity 2 Stage Wall Mount Air Conditioner

### Models:

W3SAF-A      W4SAF-A      W5SAF-A

W3SAF-B      W4SAF-B      W5SAF-B

W3SAF-C      W4SAF-C      W5SAF-C

W3SAFDA      W4SAFDA      W5SAFDA

W3SAFDB      W4SAFDB      W5SAFDB

W3SAFDC      W4SAFDC      W5SAFDC



Bard Manufacturing Company, Inc.  
Bryan, Ohio 43506  
[www.bardvac.com](http://www.bardvac.com)

Manual: 2100-822  
Supersedes: **NEW**  
Date: 11-20-24

# CONTENTS

---

<b>Safety Instructions .....</b>	<b>4</b>	<b>Start Up .....</b>	<b>33</b>
<b>General Information .....</b>	<b>12</b>	General .....	33
General .....	12	Topping Off System Charge .....	33
Shipping Damage .....	12	Safety Practices .....	33
Additional Publications .....	12	Important Installer Note .....	33
Air Conditioner Wall Mount Model Nomenclature .....	13	High Pressure Switch .....	33
Duct Work .....	14	Three Phase Scroll Compressor Start Up Information .....	34
Filters .....	14	Phase Monitor .....	34
Filter Removal/Installation .....	14	Condenser Fan Operation .....	34
Switching Filter Sizes .....	15	Service Hints .....	34
Fresh Air Intake .....	16	Sequence of Operation .....	34
<b>Installation .....</b>	<b>17</b>	Cooling .....	34
Basic Installation Design and Application Planning .....	17	No Economizer .....	34
Wall Construction .....	17	With Economizer .....	34
Outdoor Area Inspection .....	17	Balanced Climate™ Mode .....	35
Condensate Water Drainage .....	17	Vent Connection Plug .....	35
Indoor Ducted and Non-Ducted Applications .....	17	Compressor Control Module .....	35
Indoor Supply Airflow .....	17	Features .....	35
Indoor Return Airflow .....	17	Delay-on-Make Timer .....	35
Ducted Applications .....	18	Short Cycle/Delay-on-Break .....	35
Free Blow Applications .....	18	Low Pressure Detection .....	35
Thermostat or Indoor Temperature Sensor Placement .....	18	High Pressure Detection .....	35
Unit Installation .....	18	Test Mode .....	36
Materials/Tool List .....	18	Brownout Protection with Adjustment .....	36
Wall Preparation .....	19	Pressure Service Ports .....	37
Wall Mount Installation to Wall Surface .....	19	<b>Service .....</b>	<b>38</b>
Wiring – Main Power .....	26	Troubleshooting Nidec SelecTech Series ECM Motors .....	38
High Voltage Connections .....	26	If the Motor is Running .....	38
Wiring – Low Voltage .....	27	If the Motor is Not Running .....	38
Low Voltage (24VAC) Connections .....	27	Model SelecTech Communication Diagnostics .....	39
Unit Shutdown Feature .....	27	Refrigerant Leak Detection System (RDS) .....	40
Balanced Climate™ Feature .....	27	Why RDS? .....	40
Dehumidification Feature .....	28	Sequence of Operations .....	40
Ventilation Features .....	28	Power Up and Self Test .....	41
Low Ambient Control (LAC) .....	28	Normal Operation .....	41
Outdoor Temperature Switch and Freeze Protection Thermostat .....	28	Alarm State .....	41
Alarm Relay Feature .....	28	Sensor Fault Mode .....	41
DDC Controls Feature .....	28	Mitigation Mode .....	41
Dirty Filter Switch Indicator (DFS) .....	28	Alarm Reset .....	41
Discharge Air Sensor .....	28	RDS Diagnosis .....	41
Airflow Switch .....	28	Sensor End-of-Life .....	41
Compressor Current Sensor .....	28	Fan Blade Setting Dimensions .....	44
Refrigerant Leak Detection System (RDS) .....	29	R-454B Refrigerant Charge .....	44
		Removal of Fan Shroud .....	44
		Setting Unit Airflow .....	48
		Blower Speeds .....	48
		Speed Tap 1 – Vent/Blower Only .....	49
		Speed Tap 2 – Part Load/Balanced Climate .....	49
		Speed Tap 3 – Default LO Cooling .....	49
		Speed Tap 4 – Optional HI Cooling .....	49
		Speed Tap 5 – Electric Heat Speed .....	49
		Dirty Filter Switch .....	49
		Dirty Filter Switch Adjustment .....	49

## FIGURES

Figure 1	Front Control Panel Cover .....	14
Figure 2	Removing Left Filter.....	14
Figure 3	Removing Second Filter.....	15
Figure 4	Filter Tabs in Up Position.....	15
Figure 5	Bend Filter Tabs Down.....	15
Figure 6	Remove Four Screws .....	15
Figure 7	Re-Install Filter Support Brackets into Lower Slots .....	15
Figure 8	Re-Install Screws and Bend Tabs Up.....	15
Figure 9	Install Right 2" Filter.....	16
Figure 10	Install Left 2" Filter.....	16
Figure 11	Fresh Air Damper.....	16
Figure 12	Vent Installation/Removal Clearance Required .....	20
Figure 13	Unit Dimensions .....	21
Figure 14	Mounting Instructions.....	22
Figure 15	Electric Heat Clearance .....	23
Figure 16	Wall Mounting Instructions .....	24
Figure 17	Wall Mounting Instructions .....	24
Figure 18	Common Wall Mounting Installations ....	25
Figure 19	High Voltage Connections .....	26
Figure 20	Programmable Thermostat Connections .....	30
Figure 21	Programmable Thermostat Connections .....	31
Figure 22	Non-Programmable Thermostat Connections .....	32
Figure 23	Compressor Control Module.....	36
Figure 24	Motor Connections .....	38
Figure 25	Motor Connections .....	39
Figure 26	Motor Control Module.....	39
Figure 27	Refrigerant Leak Detection System .....	40
Figure 28	Sensor Status LED Blink Code.....	41
Figure 29	Refrigerant Leak Detection System (RDS) Troubleshooting .....	42
Figure 30	Refrigerant Leak Detection System (RDS) Wiring Diagram .....	43
Figure 31	Fan Blade Setting .....	44
Figure 32	Fan Shroud Removal .....	44
Figure 33	Speed Taps.....	48
Figure 34	Speed Taps.....	49
Figure 35	Dirty Filter Switch and Dirty Filter Indicator Light/Reset Switch .....	50
Figure 36	Adjusting Filter Switch .....	51

## TABLES

Table 1	Clearance Required for Service Access and Adequate Condenser Airflow.....	20
Table 2	Minimum Clearances Required to Combustible Materials.....	20
Table 3	Additional Low Voltage Connections (if applicable).....	27
Table 4	Low Voltage Connections for DDC Control .....	28
Table 5	Wall Thermostats .....	29
Table 6	CO <sub>2</sub> Controllers .....	29
Table 7	Thermostat Wire Size.....	29
Table 8	Humidity Controls .....	29
Table 9	Fan Blade Dimensions.....	44
Table 10A	Cooling Pressure – Full Load .....	45
Table 10B	Cooling Pressure – Part Load.....	46
Table 11	Electrical Specs.....	47
Table 12	Recommended Airflow.....	48
Table 13	Blower Speeds for Unit Operational Modes.....	48
Table 14	Maximum ESP Electric Heat Only.....	55
Table 15	Electric Heat .....	55
Table 16	Vent and Control Options .....	56
Table 17	Optional Accessories .....	57

## GRAPHS

Graph 1	W3SAF Indoor Airflow Performance – Wet Coil .....	52
Graph 2	W4SAF Indoor Airflow Performance – Wet Coil .....	53
Graph 3	W5SAF Indoor Airflow Performance – Wet Coil .....	54
Graph 4	W3SAF FAD-NE5 W/O Exhaust Ventilation Delivery .....	58
Graph 5	W4SAF FAD-NE5 W/O Exhaust Ventilation Delivery .....	58
Graph 6	W5SAF FAD-NE5 W/O Exhaust Ventilation Delivery .....	59

# NOTICE

**APPLIANCE ACCESSIBLE TO THE GENERAL  
PUBLIC.**

# SAFETY INSTRUCTIONS

---

## READ ALL INSTRUCTIONS BEFORE USE

### Your safety and the safety of others are very important.

We have provided many important safety messages in this manual and on your appliance. Always read and follow all safety messages.

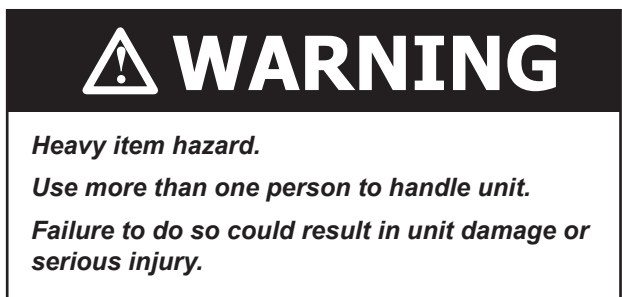
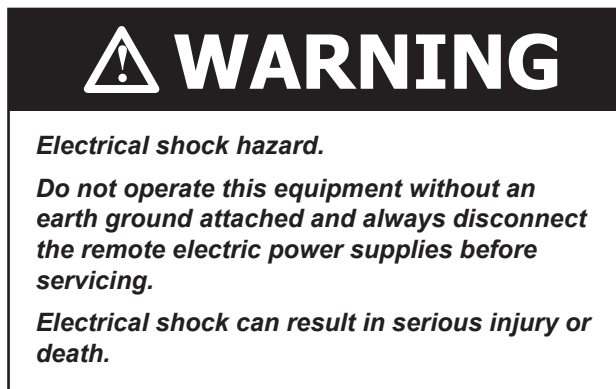
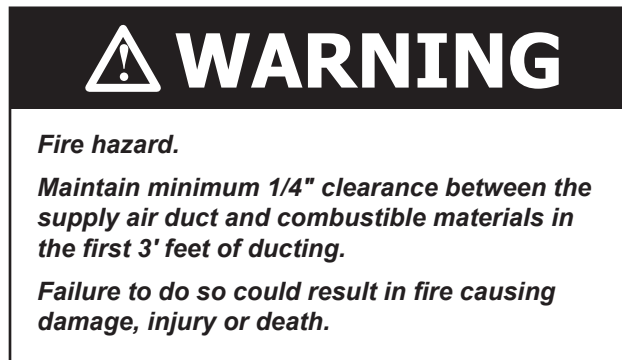
### ANSI Z535.5 Definitions:

**DANGER:** Indicate[s] a hazardous situation which, if not avoided, will result in death or serious injury. The signal word "DANGER" is to be limited to the most extreme situations. DANGER [signs] should not be used for property damage hazards unless personal injury risk appropriate to these levels is also involved.

**WARNING:** Indicate[s] a hazardous situation which, if not avoided, could result in death or serious injury. WARNING [signs] should not be used for property damage hazards unless personal injury risk appropriate to this level is also involved.

**CAUTION:** Indicate[s] a hazardous situation which, if not avoided, could result in minor or moderate injury. CAUTION [signs] without a safety alert symbol may be used to alert against unsafe practices that can result in property damage only.

**NOTICE:** [this header is] preferred to address practices not related to personal injury. The safety alert symbol shall not be used with this signal word. As an alternative to "NOTICE" the word "CAUTION" without the safety alert symbol may be used to indicate a message not related to personal injury.



## **WARNING**

**Electrical shock hazard.**

**Have a properly trained individual perform these tasks.**

**Failure to do so could result in electric shock or death.**

## **CAUTION**

**Sharp metallic edges.**

**Take care and wear appropriate protective devices to avoid accidental contact with sharp edges.**

**Failure to do so can result in personal injury.**

## **WARNING**

**Do not use means to accelerate the defrosting process or to clean, other than those recommended by the manufacturer.**

**This appliance shall be stored in a room without continuously operating ignition sources (for example: open flames, an operating gas appliance or an operating electric heater.)**

## **WARNING**

**Do not pierce or burn through copper.**

**Be aware that the refrigerant used in system may not contain an odor.**

**Ducts connected to appliance shall not contain a POTENTIAL IGNITION SOURCE.**

The following symbols are displayed on units.



This symbol indicates that the unit contains a mildly flammable refrigerant.

Refrigerant  
Safety Group  
A2L

This symbol indicates that the refrigerant used is classified as an A2L, or mildly flammable refrigerant.



This symbol indicates that the Operation Manual should be read carefully.



This symbol indicates that a service personnel should be handling this equipment with reference to the Installation Manual.



This symbol indicates that information is available such as the Operation Manual or Installation Manual.

## IMPORTANT SAFETY INSTRUCTIONS



### WARNING

**To reduce the risk of explosion, fire, death, electric shock, scalding or injury to persons when using this product, follow basic precautions, including the following:**

#### GENERAL

- The equipment covered in this manual is to be installed by trained, experienced service and installation technicians.
- This appliance is not intended for use by persons (including children) with reduced physical, sensory or mental capabilities, or lack of experience and knowledge, unless they have been given supervision or instruction concerning use of the appliance by a person responsible for their safety.
- The refrigerant system is completely assembled and charged. All internal wiring is complete.
- The unit is designed for use with or without duct work. Flanges are provided for attaching the supply and return ducts.
- These instructions explain the recommended method to install the air-cooled self-contained unit and the electrical wiring connections to the unit.
- These instructions and any instructions packaged with any separate equipment required to make up the entire air conditioning system should be carefully read before beginning the installation. Note particularly “Starting Procedure” and any tags and/or labels attached to the equipment.
- While these instructions are intended as a general recommended guide, they do not supersede any national and/or local codes in any way. Authorities having jurisdiction should be consulted before the installation is made. See Additional Publications for information on codes and standards.
- Size of unit for a proposed installation should be based on heat loss calculation made according to methods of Air Conditioning Contractors of America (ACCA). The air duct should be installed in accordance with the Standards of the National Fire Protection Association for the Installation of Air Conditioning and Ventilating Systems of Other Than Residence Type, NFPA No. 90A, and Residence Type Warm Air Heating and Air Conditioning Systems, NFPA No. 90B. Where local regulations are at a variance with instructions, installer should adhere to local codes.

#### INSTALLATION

- For appliances intended for use at altitudes exceeding 2,000 meters (6,562 feet), the maximum altitude of use shall be stated.
- Before use, the appliance must be properly installed as described in this manual.
- Contact the authorized service technician for repair or maintenance of this unit.
- Contact the installer for installation of this unit.
- The air conditioner is not intended for use by young children or invalids without supervision.
- Young children should be supervised to ensure that they do not play with the air conditioner.
- Installation work must be performed in accordance with the National Electric Code by qualified and authorized personnel only.
- Connect to a properly rated, protected, and sized power circuit to avoid electrical overload.
- Adhere to all industry recommended safety procedures including the use of long-sleeved gloves and safety glasses.
- Use care when unpacking and installing. The edges of the product may be sharp.
- Keep packaging materials out of the reach of children. These materials can pose a suffocation risk to children.
- Auxiliary devices which may be a POTENTIAL IGNITION SOURCE shall not be installed in the duct work. Examples of such POTENTIAL IGNITION SOURCES are hot surfaces with a temperature exceeding 700°C and electric switching devices.

## IMPORTANT SAFETY INSTRUCTIONS



### WARNING

---

#### OPERATION

- This appliance is not intended for use by persons (including children) with reduced physical, sensory, or mental capabilities, or lack of experience and knowledge, unless they have been given supervision or instruction concerning use of the appliance by a person responsible for their safety.
- Use this appliance only for its intended purpose.
- Never attempt to operate this appliance if it is damaged, malfunctioning, partially disassembled, or has missing or broken parts.
- Do not tamper with controls.
- Keep all required ventilation openings clear of obstructions.
- Ducts connected to an appliance shall not contain a POTENTIAL IGNITION SOURCE.

# INSTRUCTIONS DE SÉCURITÉ

## LIRE TOUTES LES INSTRUCTIONS AVANT UTILISATION

### Votre sécurité et celle des autres sont très importantes.

Nous avons fourni de nombreux messages de sécurité importants dans ce manuel et sur votre appareil. Lisez et suivez toujours tous les messages de sécurité.

### Définitions ANSI Z535.5 :

**DANGER** : Indique une situation dangereuse qui, si elle n'est pas évitée, entraînera certainement la mort ou des blessures graves. Le mot « DANGER » doit être limité aux situations extrêmes. Les indications « DANGER » ne doivent pas être utilisées pour les risques de dégâts matériels, à moins qu'il n'existe un risque concomitant de blessures corporelles.

**AVERTISSEMENT** : Indique une situation dangereuse qui, si elle n'est pas évitée, peut entraîner la mort ou des blessures graves. Les indications « AVERTISSEMENT » ne doivent pas être utilisées pour les risques de dégâts matériels, à moins qu'il n'existe un risque concomitant de blessures corporelles.

**ATTENTION** : Indique une situation dangereuse qui, si elle n'est pas évitée, peut entraîner des blessures mineures à modérées. Les indications « ATTENTION », sans symbole d'avertissement, peuvent être utilisées pour alerter sur des pratiques dangereuses pouvant entraîner des dégâts matériels uniquement.

**REMARQUE** : cet avis concerne les pratiques n'entraînant aucune blessure corporelle. Le symbole d'avertissement ne doit pas être utilisé avec ce mot. Comme alternative à « AVIS », le mot « ATTENTION » sans symbole d'avertissement peut être utilisé pour indiquer un message non lié à des blessures corporelles.



### AVERTISSEMENT

*Risque de choc électrique.*

*Ne pas faire fonctionner cet équipement sans qu'il soit relié à la terre et toujours débrancher les alimentations électriques avant de procéder aux opérations d'entretien.*

*Une électrisation peut entraîner des blessures graves ou la mort.*

### REMARQUE

**APPAREIL ACCESSIBLE AU GRAND PUBLIC.**

### AVERTISSEMENT

*Risque d'incendie.*

*Conserver un dégagement minimal de 6,35 mm/1/4 po entre le conduit d'air soufflé et les matériaux combustibles sur les 900 premiers millimètres (3 pi) du conduit.*

*Le non-respect de cette consigne entraîne des risques de dégâts matériels, de blessures corporelles ou de décès.*

### AVERTISSEMENT

*Risque lié aux objets lourds.*

*Plusieurs personnes sont nécessaires à la manipulation de l'unité.*

*Le non-respect de cette consigne peut entraîner dégâts à l'unité ou des blessures graves.*



## AVERTISSEMENT

**Risque de choc électrique.**

**Ces tâches doivent être réalisées par une personne parfaitement qualifiée et formée.**

**Le non-respect de cette consigne peut entraîner des chocs électriques ou la mort.**



## ATTENTION

**Arêtes métalliques vives.**

**Faites attention et portez des dispositifs de protection appropriés pour éviter tout contact accidentel avec des arêtes vives.**

**Le non-respect de cette consigne peut entraîner des blessures corporelles.**



## AVERTISSEMENT

**N'utilisez pas de moyens pour accélérer le processus de dégivrage ou pour nettoyer, autres que ceux recommandés par le fabricant.**

**Cet appareil doit être entreposé dans une pièce sans sources d'inflammation fonctionnant en continu (par exemple : flammes nues, un appareil à gaz en fonctionnement ou un appareil de chauffage électrique en fonctionnement).**



## AVERTISSEMENT

**Ne percez pas ou ne brûlez pas à travers le cuivre.**

**Sachez que le réfrigérant utilisé dans le système peut ne pas contenir d'odeur.**

**Les conduits raccordés à l'appareillage ne doivent pas contenir de SOURCE D'INFLAMMATION POTENTIELLE.**

Les symboles suivants sont affichés sur les unités.



Ce symbole indique que l'unité contient un réfrigérant légèrement inflammable.

Refrigerant  
Safety Group  
A2L

Ce symbole indique que le réfrigérant utilisé est classé comme réfrigérant A2L ou légèrement inflammable.



Ce symbole indique que le manuel d'utilisation doit être lu attentivement.



Ce symbole indique qu'un membre du personnel de service devrait manipuler cet équipement en se référant au manuel d'installation.



Ce symbole indique que des informations sont disponibles telles que le manuel d'utilisation ou le manuel d'installation.

## INSTRUCTIONS DE SÉCURITÉ IMPORTANTES



### AVERTISSEMENT

**Pour réduire le risque d'explosion, d'incendie, de décès, de choc électrique, d'échaudure ou de blessures pour les personnes lors de l'utilisation de ce produit, suivez les précautions de base, notamment les suivantes :**

#### GÉNÉRALITÉS

- L'équipement couvert dans ce manuel doit être installé par des techniciens de service et d'installation formés et expérimentés.
- Cet appareil n'est pas destiné à être utilisé par des personnes (y compris des enfants) ayant des capacités physiques, sensorielles ou mentales réduites, ou un manque d'expérience et de connaissances, à moins qu'elles n'aient reçu la supervision ou l'instruction concernant l'utilisation de l'appareil par une personne responsable de leur sécurité.
- Le système de réfrigérant est complètement assemblé et chargé. Tout le câblage interne est complet.
- L'unité est conçue pour être utilisée avec ou sans conduits. Des brides sont prévues pour fixer les conduits d'alimentation et de retour.
- Ces instructions expliquent la méthode recommandée pour installer l'unité autonome refroidie à l'air et les connexions de câblage électrique à l'unité.
- Ces instructions et toutes les instructions emballées avec tout équipement distinct requis pour constituer l'ensemble du système de climatisation doivent être lues attentivement avant de commencer l'installation. Notez en particulier « Procédure de démarrage » et les étiquettes et / ou étiquettes attachées à l'équipement.
- Bien que ces instructions soient conçues comme un guide général recommandé, elles ne remplacent en aucune façon les codes nationaux et/ou locaux. Les autorités compétentes devraient être consultées avant que l'installation ne soit effectuée. Voir d'autres publications pour obtenir des renseignements sur les codes et les normes.
- La taille de l'unité pour une installation proposée devrait être basée sur le calcul de la perte de chaleur effectué selon les méthodes de Air Conditioning Contractors of America (ACCA). Le conduit d'air devrait être installé conformément aux Normes de la National Fire Protection Association for the Installation of Air Conditioning and Ventilating Systems of Other Than Residence Type, NFPA No. 90A, et aux Systèmes de chauffage et de climatisation d'air chaud de type résidence, NFPA No. 90B. Lorsque les réglementations locales sont en contradiction avec les instructions, l'installateur doit respecter les codes locaux.

#### L'INSTALLATION

- Pour les appareils destinés à être utilisés à des altitudes supérieures à 2 000 mètres (6 562 pieds), l'altitude maximale d'utilisation doit être indiquée.
- Avant utilisation, l'apppliance doit être correctement installée comme décrit dans ce manuel.
- Communiquez avec le technicien d'entretien autorisé pour la réparation ou l'entretien de cette unité.
- Contactez le programme d'installation pour l'installation de cet appareil.
- Le climatiseur n'est pas destiné à être utilisé par de jeunes enfants ou des invalides sans surveillance.
- Les jeunes enfants devraient être surveillés pour s'assurer qu'ils ne jouent pas avec le climatiseur.
- Les travaux d'installation doivent être effectués conformément au Code national de l'électricité par du personnel qualifié et autorisé uniquement.
- Connectez-vous à un circuit d'alimentation correctement évalué, protégé et dimensionné pour éviter les surcharges électriques.
- Respectez toutes les procédures de sécurité recommandées par l'industrie, y compris l'utilisation de gants à manches longues et de lunettes de sécurité.
- Faites attention lors du déballage et de l'installation. Les bords du produit peuvent être tranchants.
- Gardez les matériaux d'emballage hors de la portée des enfants. Ces matériaux peuvent poser un risque d'étouffement pour les enfants.
- Les dispositifs auxiliaires qui peuvent être une SOURCE D'INFLAMMATION POTENTIELLE ne doivent pas être installés dans les conduits. Des exemples de telles SOURCES D'INFLAMMATION POTENTIELLES sont les surfaces chaudes dont la température dépasse 700 °C et les dispositifs de commutation électrique.

## INSTRUCTIONS DE SÉCURITÉ IMPORTANTES



### AVERTISSEMENT

---

#### OPÉRATION

- Cet appareil n'est pas destiné à être utilisé par des personnes (y compris des enfants) ayant des capacités physiques, sensorielles ou mentales réduites, ou un manque d'expérience et de connaissances, à moins qu'elles n'aient reçu une supervision ou une instruction concernant l'utilisation de l'appareil par une personne responsable de leur sécurité.
- Utilisez cet appareil uniquement aux fins prévues.
- N'essayez jamais de faire fonctionner cet appareil s'il est endommagé, défectueux, partiellement démonté ou s'il a des pièces manquantes ou cassées.
- Ne pas altérer les contrôles.
- Gardez toutes les ouvertures de ventilation nécessaires à l'écart des obstacles.
- Les conduits raccordés à un appareil ne doivent pas contenir de SOURCE D'INFLAMMATION POTENTIELLE.

# GENERAL INFORMATION

---

## General

The equipment covered in this manual is to be installed by trained, experienced service and installation technicians.

This appliance is not intended for use by persons (including children) with reduced physical, sensory or mental capabilities, or lack of experience and knowledge, unless they have been given supervision or instruction concerning use of the appliance by a person responsible for their safety.

Children should be supervised to ensure that they do not play with the appliance.

The refrigerant system is completely assembled and charged. All internal wiring is complete.

The unit is designed for use with or without duct work. Flanges are provided for attaching the supply and return ducts.

These instructions explain the recommended method to install the air cooled self-contained unit and the electrical wiring connections to the unit.

These instructions and any instructions packaged with any separate equipment required to make up the entire air conditioning system should be carefully read before beginning the installation. Note particularly "Starting Procedure" and any tags and/or labels attached to the equipment.

While these instructions are intended as a general recommended guide, they do not supersede any national and/or local codes in any way. Authorities having jurisdiction should be consulted before the installation is made. See following section for information on codes and standards.

Size of unit for a proposed installation should be based on heat loss calculation made according to methods of Air Conditioning Contractors of America (ACCA). The air duct should be installed in accordance with the Standards of the National Fire Protection Association for the Installation of Air Conditioning and Ventilating Systems of Other Than Residence Type, NFPA No. 90A, and Residence Type Warm Air Heating and Air Conditioning Systems, NFPA No. 90B. Where local regulations are at a variance with instructions, installer should adhere to local codes.

## Shipping Damage

Upon receipt of equipment, the carton should be checked for external signs of shipping damage. If damage is found, the receiving party must contact the last carrier immediately, preferably in writing, requesting inspection by the carrier's agent.

## Additional Publications

These publications can help when installing the air conditioner. They can usually be found at the local library or purchased directly from the publisher. Be sure to consult the current edition of each standard.

National Electrical Code .....ANSI/NFPA 70

Standard for the Installation of Air Conditioning and Ventilating Systems  
.....ANSI/NFPA 90A

Standard for Warm Air Heating and Air Conditioning Systems  
.....ANSI/NFPA 90B

Load Calculation for Winter and Summer Air Conditioning  
..... ACCA Manual J Residential

Duct Design for Residential Winter and Summer Air Conditioning and Equipment Selection  
..... ACCA Manual D

For more information, contact these publishers:

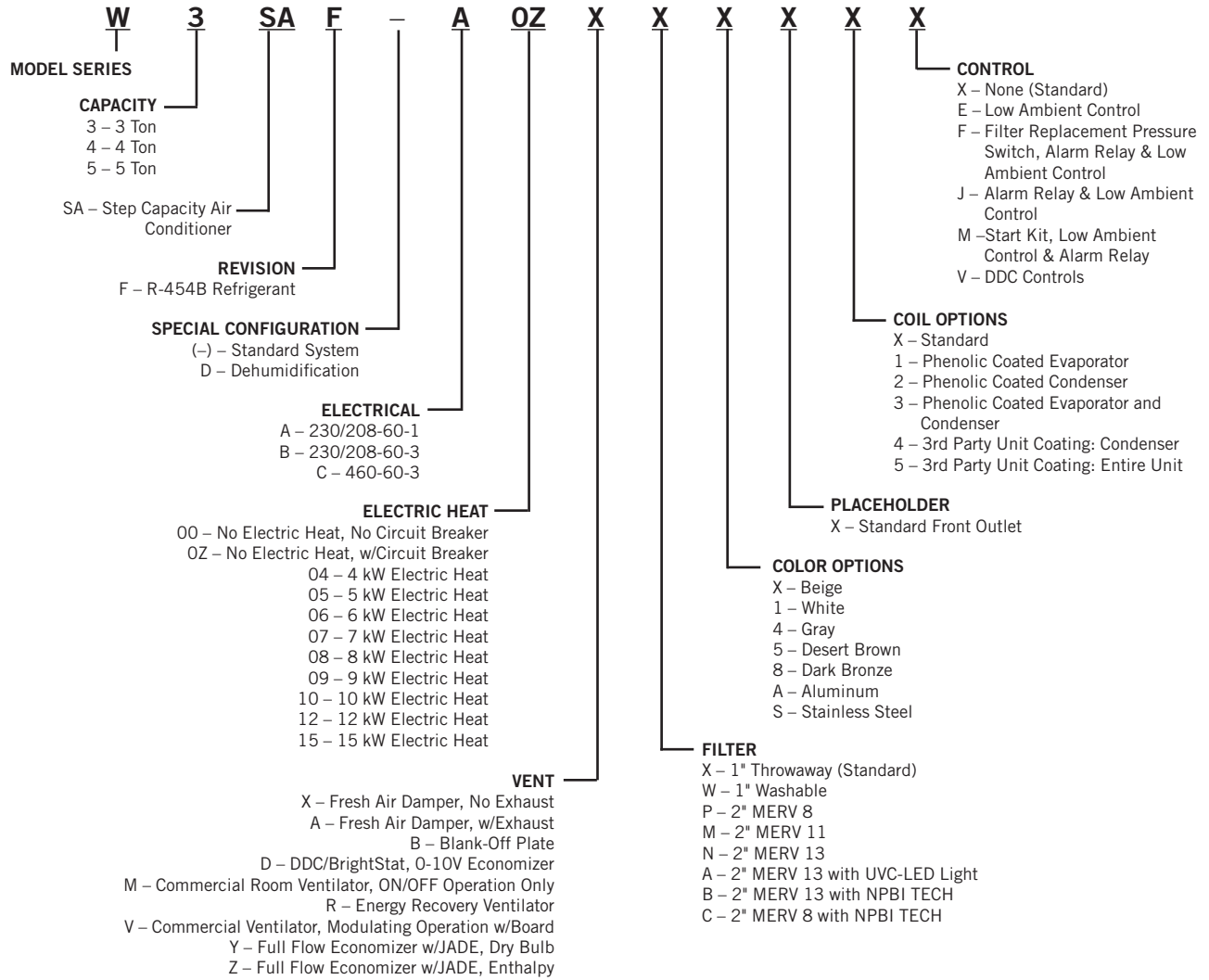
**ACCA**      **Air Conditioning Contractors of America**  
1712 New Hampshire Ave. N.W.  
Washington, DC 20009  
Telephone: (202) 483-9370  
Fax: (202) 234-4721

**ANSI**      **American National Standards Institute**  
11 West Street, 13th Floor  
New York, NY 10036  
Telephone: (212) 642-4900  
Fax: (212) 302-1286

**ASHRAE**    **American Society of Heating, Refrigeration and Air Conditioning Engineers, Inc.**  
1791 Tullie Circle, N.E.  
Atlanta, GA 30329-2305  
Telephone: (404) 636-8400  
Fax: (404) 321-5478

**NFPA**      **National Fire Protection Association**  
Batterymarch Park  
P.O. Box 9101  
Quincy, MA 02269-9901  
Telephone: (800) 344-3555  
Fax: (617) 984-7057

# Air Conditioner Wall Mount Model Nomenclature



## Duct Work

All duct work, supply and return, must be properly sized for the design airflow requirement of the equipment. Air Conditioning Contractors of America (ACCA) is an excellent guide to proper sizing. All duct work or portions thereof not in the conditioned space should be properly insulated in order to both conserve energy and prevent condensation or moisture damage.

Refer to Maximum ESP of Operation Electric Heat table on page 55.

Design the duct work according to methods given by the Air Conditioning Contractors of America (ACCA). When duct runs through unheated spaces, it should be insulated with a minimum of 1" of insulation. Use insulation with a vapor barrier on the outside of the insulation. Flexible joints should be used to connect the duct work to the equipment in order to keep the noise transmission to a minimum.

All model series require a 1/4" clearance to combustible material for the first 3' of duct attached to the outlet air frame is required. See instructions on page 18 and Figures 14 – 18 (pages 22 – 25) for further details.

Ducts through the walls must be insulated and all joints taped or sealed to prevent air or moisture entering the wall cavity.

Some installations may not require a return air duct. A metallic return air grille is required with installations not requiring a return air duct. The spacing between louvers on the grille shall not be larger than 5/8".

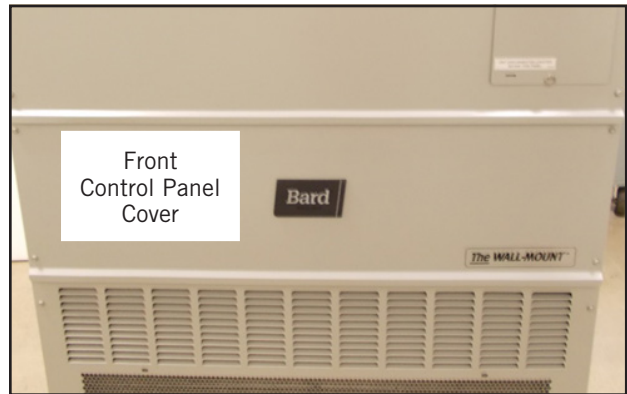
Any grille that meets with 5/8" louver criteria may be used. It is recommended that Bard Return Air Grille Kits RG5 or RFG5 be installed when no return duct is used. Contact distributor or factory for ordering information. If using a return air filter grille, filters must be of sufficient size to allow a maximum velocity of 400 fpm.

**NOTE:** *If no return air duct is used, applicable installation codes may limit this cabinet to installation only in a single story structure.*

## Filters

The filters can be serviced from the outside by removing the front control panel cover (see Figure 1). Two (2) 20" x 20" x 1" throwaway filters come standard with each unit. Additional 1" and 2" filter options are available as optional accessories. To be notified when filters need changed, a dirty filter switch option is available. See page 56 for the dirty filter switch kit.

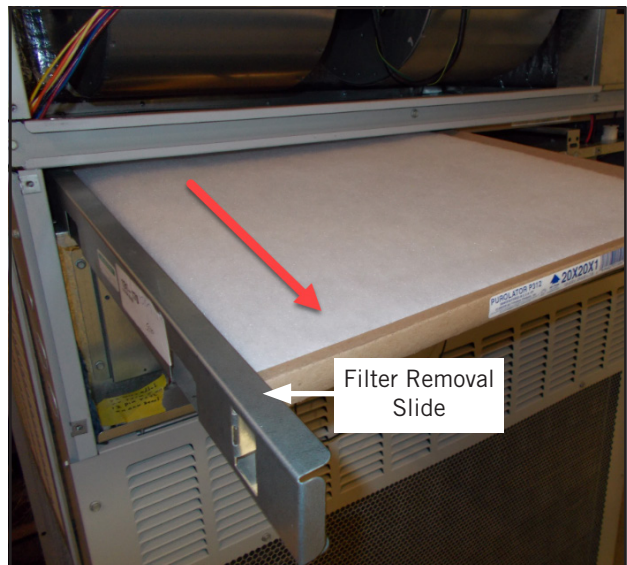
**FIGURE 1**  
**Front Control Panel Cover**



### Filter Removal/Installation

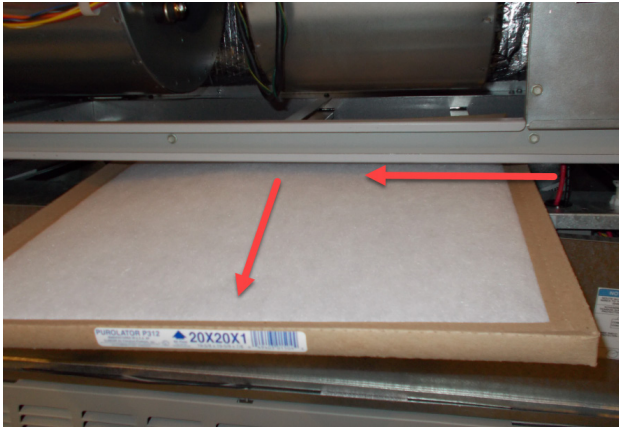
1. Remove left filter first by pulling on filter removal slide (see Figure 2).

**FIGURE 2**  
**Removing Left Filter**



2. Slide second filter to the left around the wires and pull the filter out (see Figure 3).

**FIGURE 3**  
**Removing Second Filter**



3. Reverse the order for new filter installation.

**NOTE:** When installing new filters, make sure that airflow arrows on filters point up.

**Switching Filter Sizes**

1. To switch from 1" to 2" filters, start by removing the filter slide and bend the tabs down out of the way (see Figures 4 and 5).

**FIGURE 4**  
**Filter Tabs in Up Position**



**FIGURE 5**  
**Bend Filter Tabs Down**



2. Locate the filter support brackets and remove the four (4) screws holding them to the top of the control panel (see Figure 6).

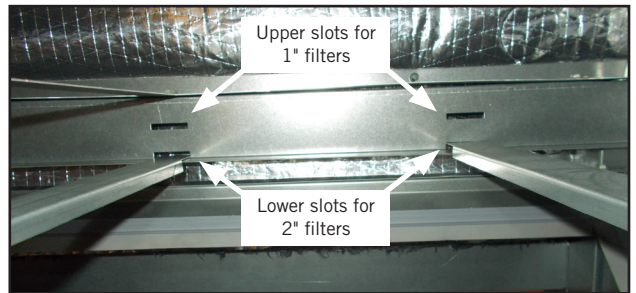
**FIGURE 6**  
**Remove Four Screws**



3. Pull the brackets out towards the front of the unit. The back of the bracket will slip out of the upper slots at the back of the filter tray.

4. Re-install the filter support brackets into the lower slots at the back of the filter tray (see Figure 7).

**FIGURE 7**  
**Re-Install Filter Support Brackets into Lower Slots**



5. Re-install the four (4) screws into the upper screw holes on the filter support brackets. Then bend the tab up out of the way (see Figure 8).

**FIGURE 8**  
**Re-Install Screws and Bend Tabs Up**



6. Install the right 2" filter first followed by the left filter (see Figures 9 and 10).

**NOTE:** When installing new filters, make sure that airflow arrows on filters point up.

7. Reverse the steps above to switch from 2" to 1" filters.

**FIGURE 9**  
Install Right 2" Filter



**FIGURE 10**  
Install Left 2" Filter



## Fresh Air Intake

All units are built with fresh air inlet louvers punched in the side grilles.

If the unit is equipped with a fresh air damper assembly, the assembly is shipped already attached to the unit. Remove right side grille to access the damper blade.

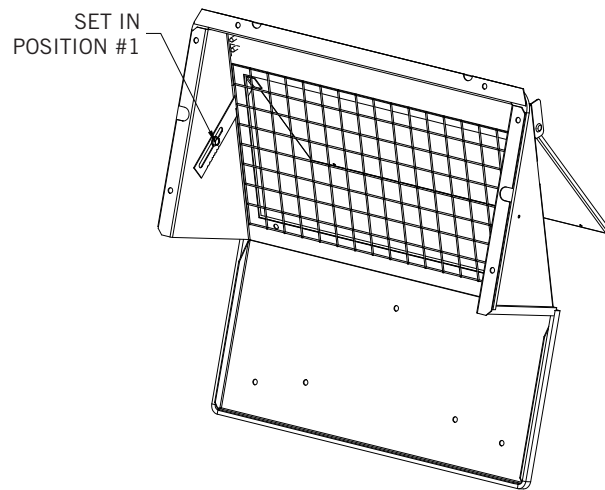
There is an adjustable slide on the side of the fresh air intake that can be adjusted to limit how far the damper opens so that the amount of fresh air that enters the structure is regulated. The damper is shipped pre-set in the #1 position.

Graphs found on pages 58 and 59 give approximate fresh air amounts based on the slide adjustment setting.

All capacity, efficiency and cost of operation information is based upon the fresh air blank-off plate in place.

The blank-off plate is available upon request from the factory and is installed in place of the fresh air damper shipped with each unit.

**FIGURE 11**  
Fresh Air Damper



MIS-3977A

## Basic Installation Design and Application Planning

Successful unit installations require proper planning and site inspection before installation begins. Before installing the wall mount unit, make sure that all service and airflow clearances are met and that the unit can meet all applicable code and regulation requirements. Provide an inspection of both the inside and outside of the structure by reviewing floorplans and/or visiting the installation site.

### Wall Construction

The wall must be inspected to ensure that the weight of the unit can be supported. Be sure to review all applicable construction codes and regulations including seismic requirements. When inspecting wood frame walls, the wall construction must be strong and rigid enough to carry the weight of the unit without transmitting any unit vibration. It is important that the side unit wall mounting lags and optional bottom bracket are supported by structural members inside the wall cavity. Concrete block and brick walls must be thoroughly inspected to ensure that they are capable of carrying the weight of the installed unit. Metal buildings must contain structural components to support the unit weight. If heavily corrugated siding is present, it may need to be trimmed and flashed similar to a window to provide a flat, even surface to attach and seal the unit to the wall. Heavy gauge corrugations that would be present on shipping containers and blast-proof structures may require the installation of a metal plate over the corrugated area. It is important that the unit area is weatherized and sealed to avoid air and water infiltration into the area between the unit and the wall.

### Outdoor Area Inspection

Inspect the outdoor area of the jobsite or review construction plans and locate the area where the wall mount is to be installed. The outdoor area must be free from obstructions including fences, bushes and walls that will hinder unit operation regarding outdoor condenser airflow and unit serviceability. Do not install units in enclosed areas that limit the amount of ambient temperature airflow. Warm air will exit the front condenser section of the unit, and outdoor ambient temperature air must be able to enter side intake condenser openings of the unit. Portable or modular building placement must be in a way that the wall mount units have a constant supply of outdoor air for proper unit operation. Make sure that the service panels of the unit are accessible. Inspect wall surfaces for obstructions that could hinder unit installation and servicing including outdoor electrical conduits, junction boxes, wall drains, vent hoods, windows, doors, overhangs and posts.

### Condensate Water Drainage

Review all codes and requirements for unit condensate drainage. A clear, flexible PVC drain hose (3/4" ID, 1" OD) extends from the drain pan in the upper section of the unit and extends down to the unit base. An opening is supplied towards the back of the unit base for the drain hose to pass through, and the hose extends 1" to 2" below the unit base. Water removed from the indoor air (condensate) will be expelled from the unit in large amounts during cooling operation through the hose. Units running in cooling operation in cold outdoor below freezing conditions can cause the condensate to freeze after leaving the drain hose. In the event the drain hose is connected to a drain system of some type, it must be an open or vented type system to ensure proper drainage throughout seasonal use.

## Indoor Ducted and Non-Ducted Applications

Air distribution inside the structure being conditioned plays an important role in making sure the area is a consistent temperature. Improper air distribution can result in areas being cooler or warmer, electrical equipment not receiving sufficient airflow or occupancy discomfort felt inside an area. Thermostat or indoor temperature sensor placement inside the area being conditioned also plays an important role in indoor climate control.

### Indoor Supply Airflow

Indoor installation areas must provide a non-restrictive path for the conditioned supply air to leave supply grilles and registers. Inspect the area to ensure that all indoor portions of the room or rooms will have access to supply air. Ductwork may be used to ensure proper air circulation and all provided ductwork guidelines and clearances must be followed. Non-ducted applications must use a supply louver grille installed over the supply opening inside the room. Be sure to adjust supply deflectors to properly disperse the conditioned supply air to all parts of the room. Avoid closing sections of the supply grilles which would cause unneeded supply duct pressurization.

### Indoor Return Airflow

A non-restrictive path for room air returning to the center section of the unit must be provided inside the room. Avoid placing objects including furniture, electronics equipment, equipment racks and cabinets directly in front of the unit return grilles and registers. Bard recommends at least 2' between solid objects and return grilles or registers. Ductwork may be used to ensure proper air circulation and all provided ductwork guidelines and clearances must be followed. Non-ducted applications must use a return louver grille installed over the return opening inside the room.

## Ducted Applications

Field fabricated supply and return duct work may be installed inside the structure being conditioned. A short supply and/or return stub duct may be connected to the unit supply and return flanges before unit installation to help with duct connections inside the structure. Supply and return ducts must be properly sized for the design airflow requirement of the equipment. Air Conditioning Contractors of America (ACCA) is an excellent guide to proper sizing. All duct work or portions thereof not in the conditioned space should be properly insulated in order to conserve energy, reduce heat conductivity, and prevent condensation or moisture damage. Refer to Maximum External Static Pressure (ESP) of Operation Table 14 on page 55. Design the duct work according to methods given by the Air Conditioning Contractors of America (ACCA). When duct work is installed in unheated spaces, it should be insulated with a minimum of 1" of insulation. Use insulation with a vapor barrier on the outside of the insulation. Flexible joints should be used to connect the duct work to the equipment in order to keep the noise transmission to a minimum. Ducts through the walls must be insulated and all joints taped or sealed to prevent air or moisture from entering the wall cavity.

All model series require a 1/4" clearance to combustible material for the first 3' of duct attached to the outlet air frame is required. See **Unit Installation** and Figures 14 – 18 (pages 22 – 25) for further details.

# WARNING

**Fire hazard.**

**Maintain minimum 1/4" clearance between the supply air duct and combustible materials in the first 3' of ducting.**

**Failure to do so could result in fire causing damage, injury or death.**

## Free Blow Applications

Some installations may not require extensive supply duct work throughout the structure and are referred to as free blow applications. A short field-fabricated supply duct must be used in the wall cavity to transition between the supply collar on the unit and the supply louver grille in the room. The duct must be properly insulated in order to conserve energy, reduce heat conductivity and prevent condensation or moisture damage. All joints must be taped or sealed to prevent air or moisture entering the wall cavity. Follow all clearances including distances to combustible materials and all instructions provided in this manual.

A non-restrictive metallic supply air grille with deflectors is required for free blow applications. Contact the local Bard distributor or visit [www.bardhvac.com](http://www.bardhvac.com) for ordering information.

A metallic return air grille is required for non-ducted applications. The spacing between louvers on the grille shall not be larger than 5/8". It is recommended that a Bard Return Air Grille Kit is installed that is designed specifically for the wall mount product. Contact the local Bard distributor or visit [www.bardhvac.com](http://www.bardhvac.com) for ordering information. A field-supplied return grille that meets the 5/8" louver criteria and does not cause the unit to exceed the maximum specified external static pressure (ESP) may be used. If using a return air filter grille, filters must be of sufficient size to allow a maximum velocity of 400 fpm. Filter return air grilles do not filter air being brought into the structure through ventilation options including fresh air dampers, ventilators, economizers and energy recovery ventilators. Be sure to install the return grille with the louvers pointed downward towards the floor. This will help ensure return air is drawn upward from the floor and improve air circulation in the room.

**NOTE:** *If no return air duct is used, applicable installation codes may limit this cabinet to installation only in a single story structure.*

## Thermostat or Indoor Temperature Sensor Placement

The location and installation of the thermostat or temperature sensor that monitors indoor temperature is very important regarding unit operation. Avoid placing the thermostat in an area exposed to direct sunlight or air from doorways leading outdoors. Use a piece of insulating material to close off conduit openings or holes in the wall surface for wire entry into the thermostat or temperature sensor. This will help avoid non-conditioned air from entering the thermostat and effecting temperature and/or humidity readings. As common practice, the thermostat or temperature sensor should measure the temperature of the air being returned to the unit, and not the conditioned air being supplied by the unit. Placing the thermostat or temperature sensor near a return air opening will normally result in optimal unit performance.

## Unit Installation

Make sure to have the proper tools at the work site that are needed for unit installation. The following steps are provided to ensure the unit is installed properly to the wall surface, and that the unit will provide years of service with minimal service requirements.

### Materials/Tools List

Additional hardware and miscellaneous supplies are needed for installation. These items are field supplied and must be sourced before installation. This list also includes tools needed for installation.

- Appropriate safety gear including gloves and safety glasses
- 5/16" hex bit with drill driver
- Phillips head screwdriver
- Small straight (thermostat) screwdriver
- Tape measure
- Leveling device
- Two (2) tubes of caulk and caulk gun
- Utility knife
- Tools for cutting holes in the wall surface (if needed)
- Electrical components and wiring along with electrical tools
- Multimeter
- Wall fasteners for side flanges, bottom mounting bracket and top rain flashing
- Duct tape and/or other duct sealing materials

### Wall Preparation

1. Two holes for the supply and return air openings must be cut through the wall as shown in Figure 14 on page 22. Be sure the openings are square and level. Follow all clearances including distances to combustible materials and all instructions provided in this manual.
2. Review all electrical requirements provided in this manual and plan out electrical entrances into the building. Also plan electrical conduit routing and thermostat placement, if necessary.
3. Install necessary duct work and prepare the openings for unit installation.
4. Clean the exterior wall where the unit is to be installed and make sure it is able to provide a smooth, level, debris-free surface. Remove all construction debris from the supply, return and electrical hole cutting process.

### Wall Mount Installation to Wall Surface

1. Remove packaging from unit and make sure the unit is not damaged before installation. A top rain flashing is supplied for field use and is mounted to the back of the unit for shipping. Remove the rain flashing before locating the unit against the wall. Top rain flashing is required to avoid water entering the area behind the unit that is against the wall. A bottom mounting bracket, attached to the skid for shipping, is provided for ease of installation but is not required. Review all requirements listed on unit labels and on serial plate located on the side of the unit.
2. Locate and mark bolt hole locations and bottom mounting bracket location. Install bottom mounting bracket with field-supplied fasteners to

wall if it is to be used (optional). Bracket must be level and installed in the correct location to help support the unit during the installation process (see Figure 14).

3. Position the wall mount unit close to the wall surface where it will be installed. Install rain flashing at the top of the unit facing the wall by hooking the hem bend into the rear bend of the unit top (see Figure 14).
4. Apply a liberal amount of caulk on left and right cabinet side wall mount brackets and back of top rain flashing. Place unit back surface flush against wall. Unit must be level to ensure proper condensate drainage. Optional bottom bracket may be used to help support the unit.
5. Units are secured to the wall by using field-supplied fasteners along each side of the wall mount through the built-in wall mounting brackets. It is the responsibility of the installer to select the proper fastener to secure the unit to the wall based on wall construction and applicable building codes. Typical installations may include 5/16" fasteners with 7/8" diameter flat washers. Be sure unit is securely mounted and all weight-bearing fasteners are attached to the weight supporting structural members of the wall.
6. Apply a bead of caulk between the back of the unit top and the front surface of the top rain flashing (see Figure 14).
7. Connect unit duct work from the inside of the building following all clearances and instructions provided. For additional mounting rigidity, the return air and supply air frames or collars can be drilled and screwed or welded to the structural wall itself (depending upon wall construction). Be sure to use code approved duct tape or other sealing materials to seal the duct work to the unit.
8. On side-by-side installations, maintain a minimum of 20" clearance on both sides to allow access to heat strips and to provide proper airflow to the outdoor coil. Additional clearance may be required to meet local or national codes.

**TABLE 1**  
**Clearance Required for Service Access and Adequate Condenser Airflow**

Model	Left Side	Right Side	Discharge – Front
W3SAF W4SAF W5SAF	20"	20"	10'

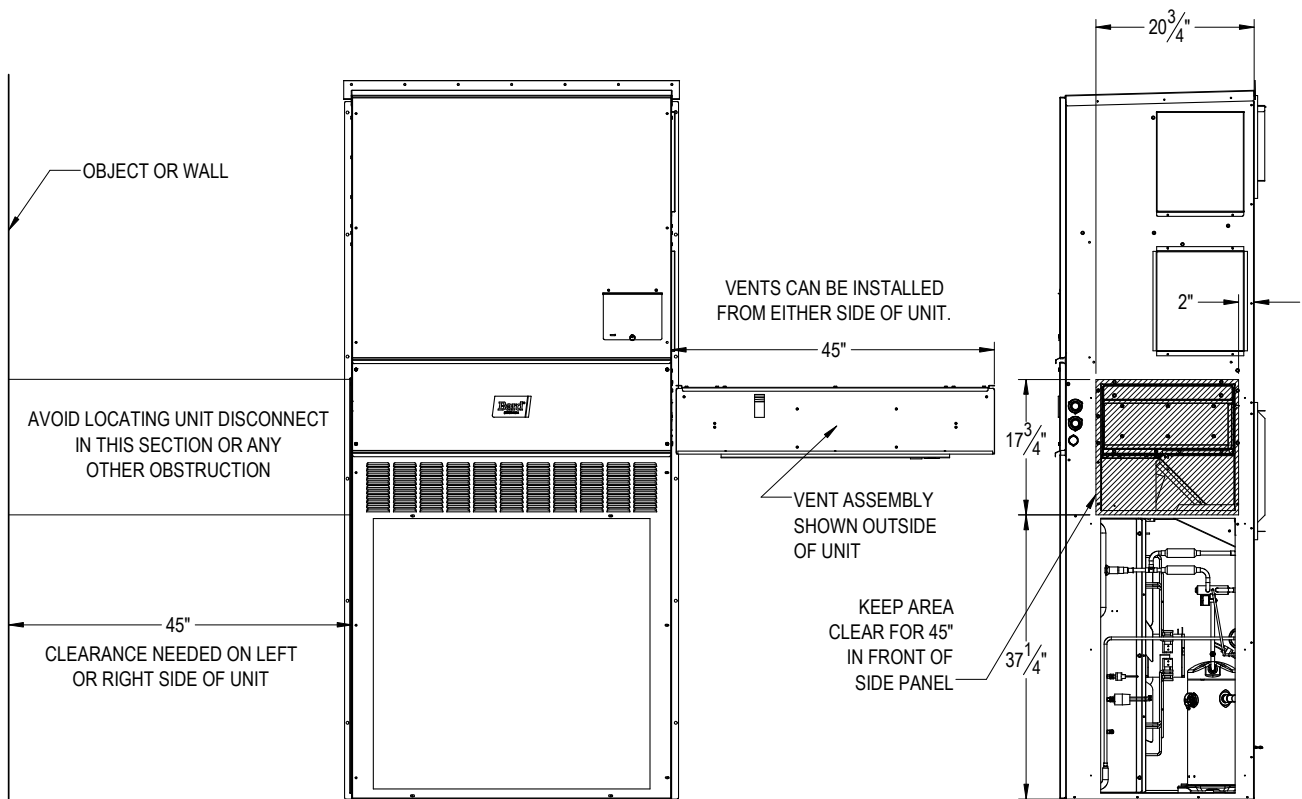
**TABLE 2**  
**Minimum Clearances Required to Combustible Materials**

Model	Supply Air Duct (1st 3')	Cabinet
W3SAF W4SAF W5SAF	1/4"	0"

\* For vent installation and removal, one side of the unit requires 45" clearance in the vent area. See Figure 12 for clarity.

See Specifications Sheet S3658.

**FIGURE 12**  
**Vent Installation/Removal Clearance Required**

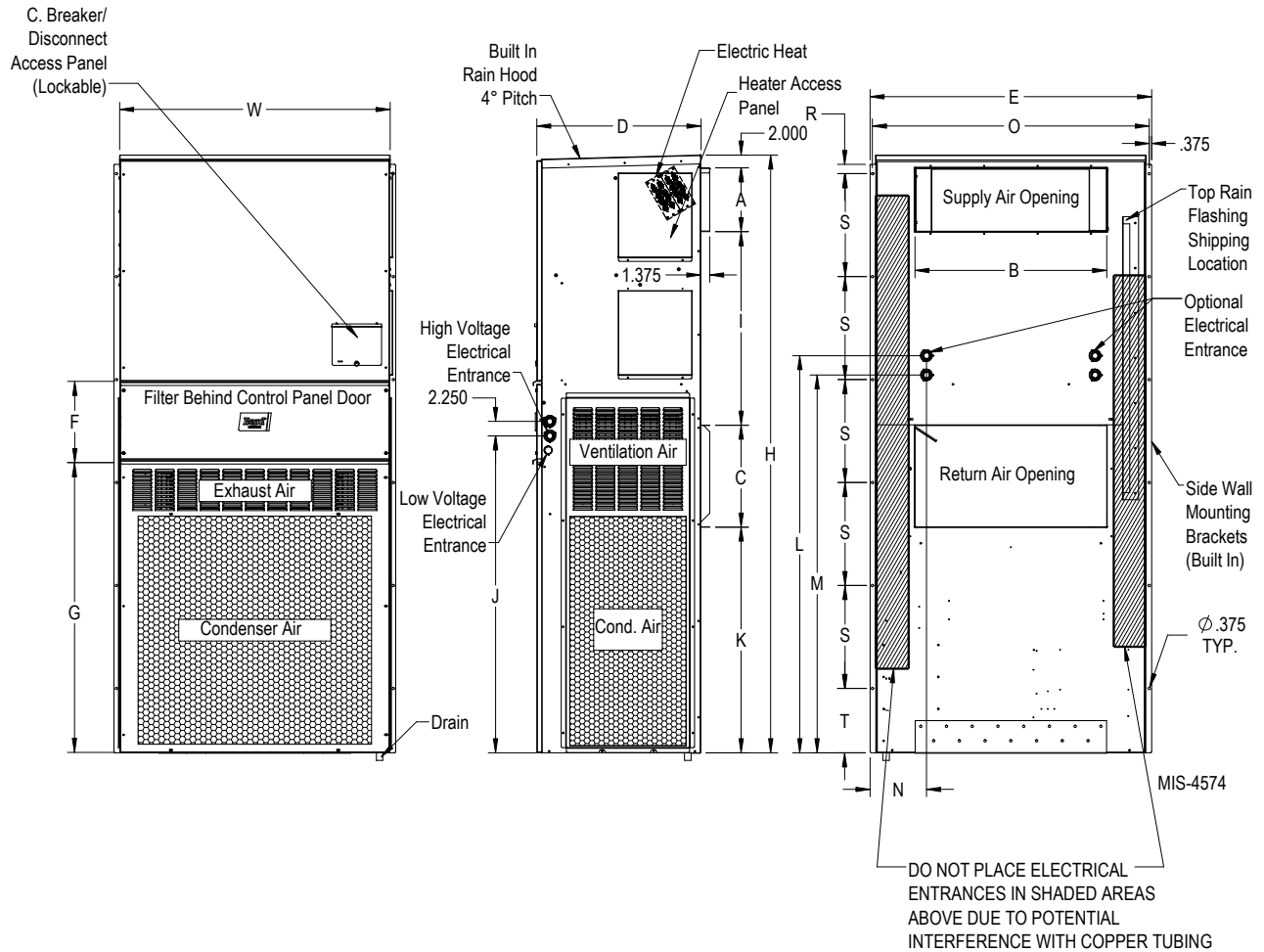


MIS-4042 A

**FIGURE 13**  
**Unit Dimensions**

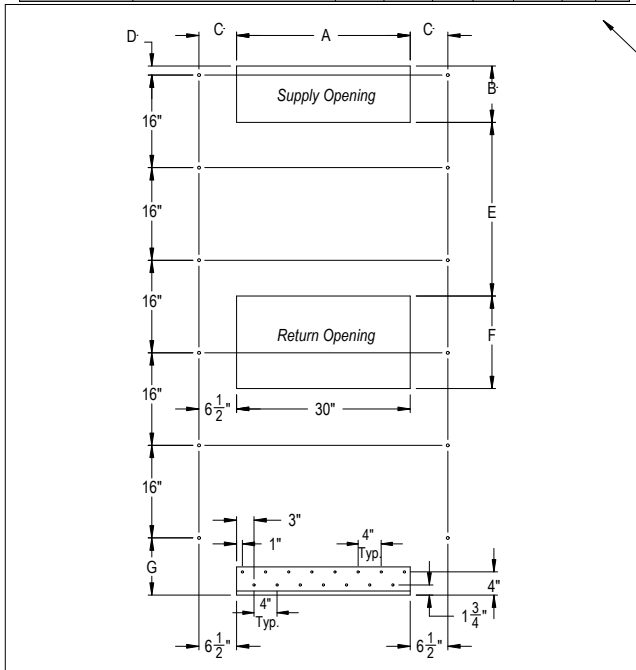
	Width (W)	Depth (D)	Height (H)	Supply		Return														
				A	B	C	B	E	F	G	I	J	K	L	M	N	O	R	S	T
W3SAF W4SAF	42.00	25.52	84.75	9.88	29.88	15.88	29.88	43.88	12.63	39.06	30.06	43.25	26.94	55.59	52.59	8.82	43.00	1.44	16.00	1.88
W5SAF	42.00	25.52	92.88	9.88	29.88	15.88	29.88	43.88	12.63	45.00	30.06	49.25	35.06	61.72	58.72	8.82	43.00	1.44	16.00	10.00

All dimensions are in inches. Dimensional drawings are not to scale.

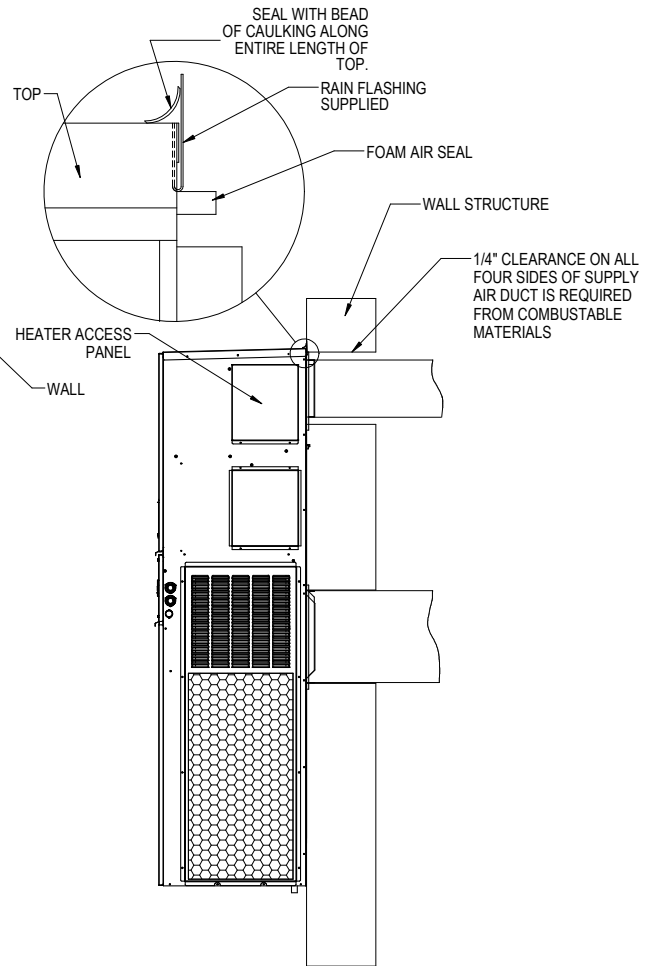


**FIGURE 14**  
**Mounting Instructions**

UNITS	REQUIRED DIMENSIONS	A	B	C	D	E	F	G
W3SAF W4SAF	REQUIRED DIMENSIONS TO MAINTAIN 1/4" MIN. CLEARANCE FROM COMBUSTIBLE MATERIALS	30 1/2	10 1/2	6 1/4	1 1/4	29 3/4	16	17 7/8
	REQUIRED DIMENSIONS TO MAINTAIN RECOMMENDED 1" CLEARANCE FROM COMBUSTIBLE MATERIALS	32	12	5 1/2	2	29	16	17 7/8
W5SAF	REQUIRED DIMENSIONS TO MAINTAIN 1/4" MIN. CLEARANCE FROM COMBUSTIBLE MATERIALS	30 1/2	10 1/2	6 1/4	1 1/4	29 3/4	16	9 7/8
	REQUIRED DIMENSIONS TO MAINTAIN RECOMMENDED 1" CLEARANCE FROM COMBUSTIBLE MATERIALS	32	12	5 1/2	2	29	16	9 7/8



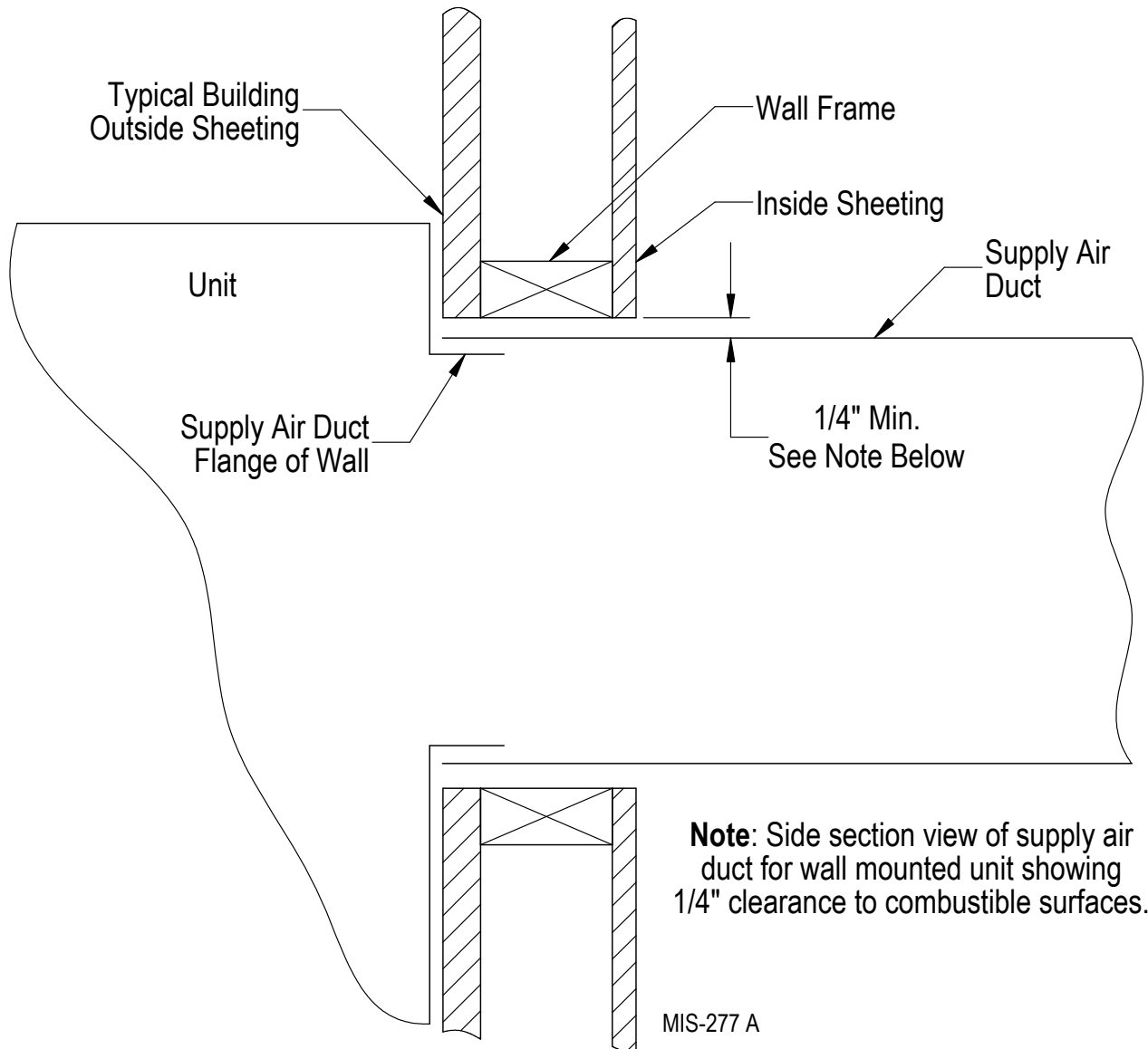
Wall Opening and Hole Location View



Right Side View

MIS-3980 D

**FIGURE 15**  
**Electric Heat Clearance**



**⚠ WARNING**

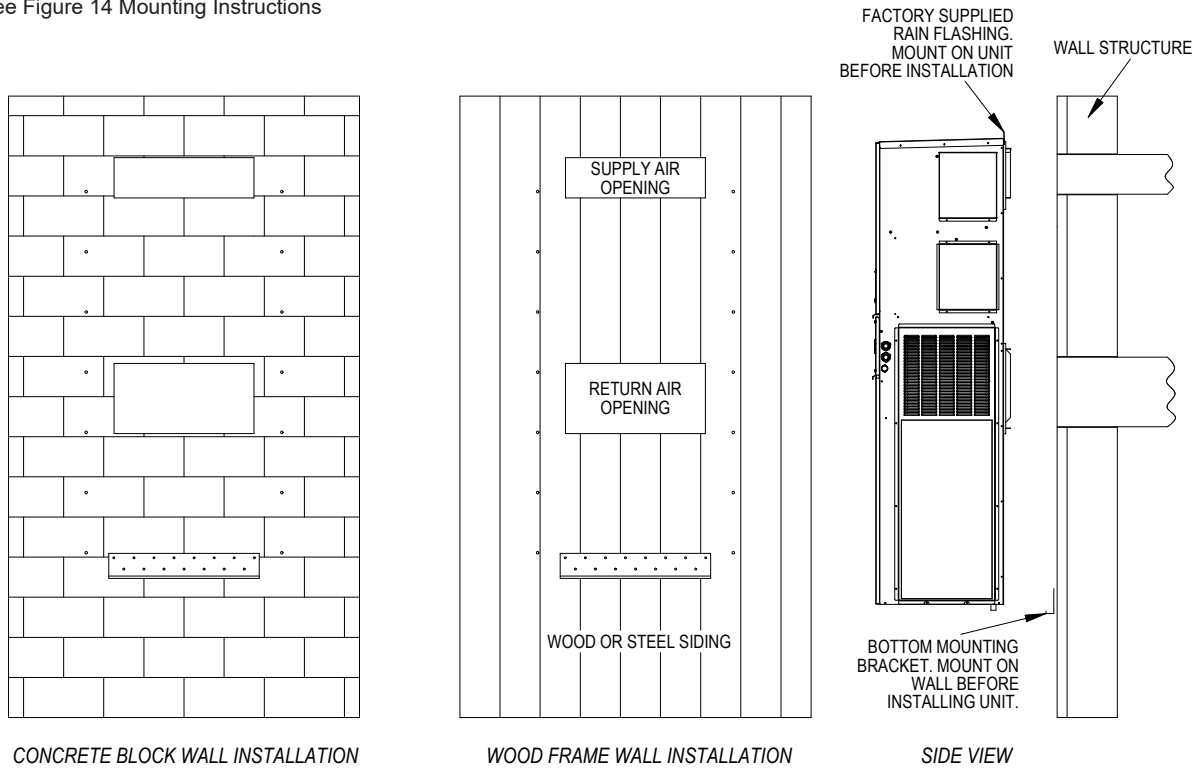
**Fire hazard.**

**Maintain minimum 1/4" clearance between the supply air duct and combustible materials in the first 3' of ducting.**

**Failure to do so could result in fire causing damage, injury or death.**

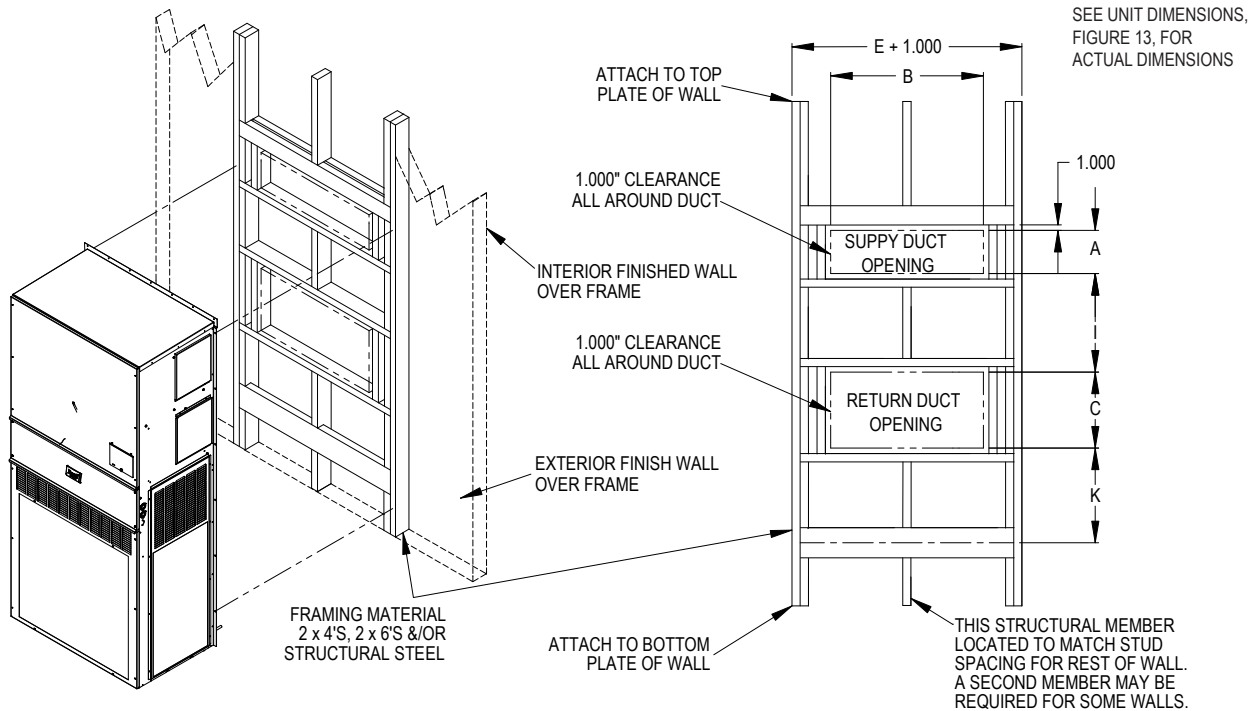
**FIGURE 16**  
**Wall Mounting Instructions**

See Figure 14 Mounting Instructions



MIS-3981 C

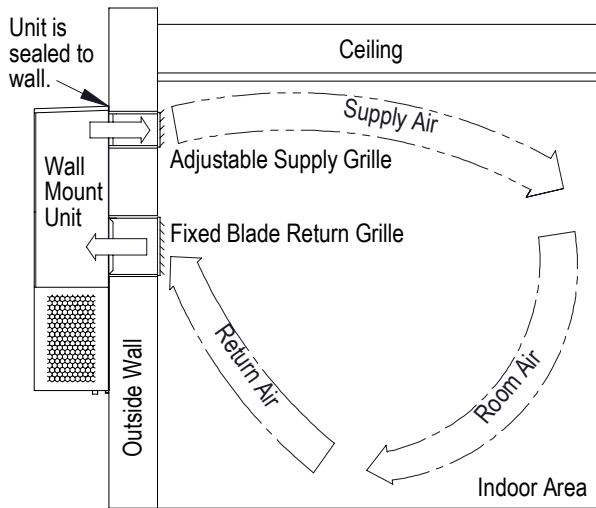
**FIGURE 17**  
**Wall Mounting Instructions**



MIS-3982 B

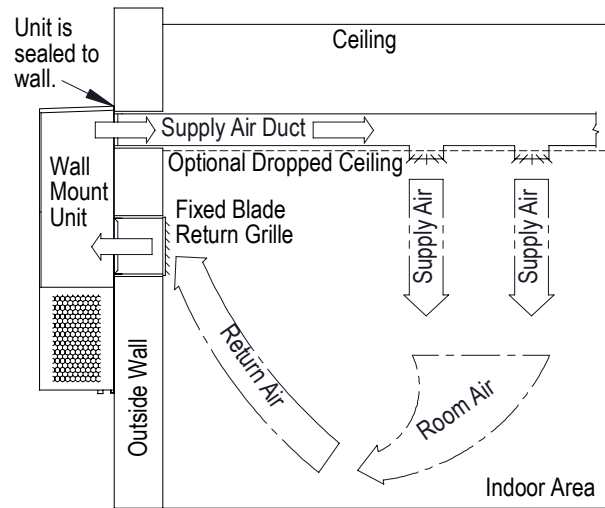
**FIGURE 18**  
Common Wall Mounting Installations

**Non-Ducted Installations**



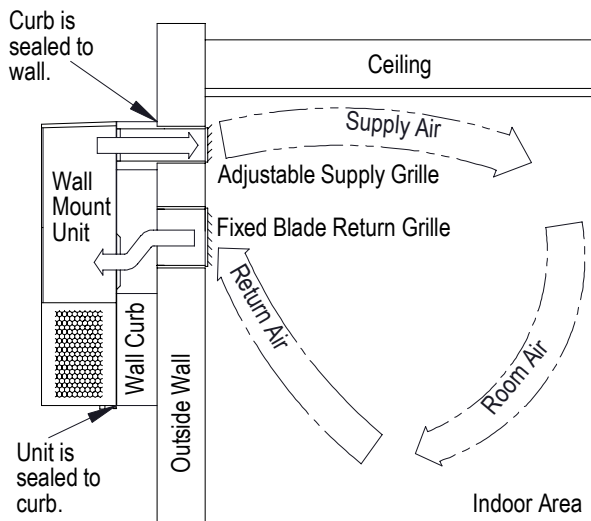
Non-ducted installations supply conditioned air into indoor room areas without extensive duct work. The supply airstream is directed by adjusting the 4-way supply grille to reach areas being conditioned. The supply air mixes with the room air and cools or heats occupants and/or equipment in the area. Unconditioned room air is returned to the unit through the return grille. Avoid supply air leaving supply grille and re-entering the unit return grille without mixing with room air.

**Ducted Installations**



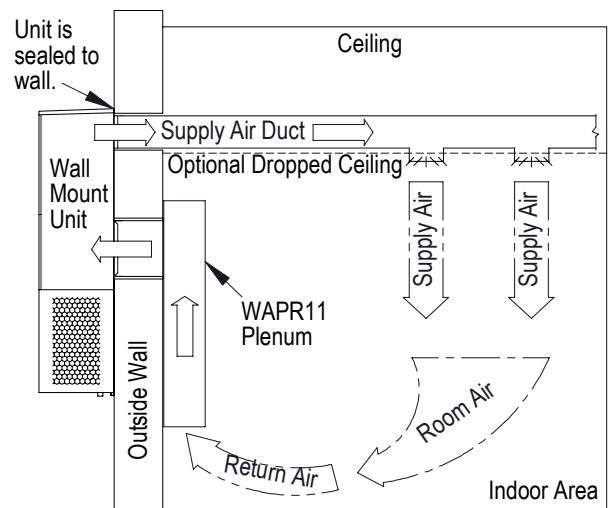
Ducted installations supply conditioned air into indoor room areas using solid or flexible ducts. The supply air is distributed throughout a single area or multiple areas. The supply air mixes with the room air and cools or heats occupants and/or equipment. Unconditioned room air is returned to the unit through a return grille or return duct work. Avoid using restrictive duct work to provide the best unit performance and efficiency. Review duct static pressure requirements provided in this manual.

**Outdoor Wall Curb Installations**



Outdoor Wall curbs are installed between the wall mount unit and the outer wall surface. Wall curb use may avoid resizing supply and return openings that are currently in an existing wall. Wall curbs may also provide sound isolation and indoor area sound reduction. Various curb options are available, and it is important to select a curb that will meet the application requirements and also be the correct size for the unit. Unit duct static requirements cannot be exceeded when using a wall curb. Follow all instructions provided with the wall curb when installing the product.

**WAPR11 Indoor Sound Plenum Installations**



Indoor sound plenums are installed inside the room over the unit return air opening. Plenum use can provide sound isolation and indoor area sound reduction. The WAPR11 sound plenum provides a single solution for all unit tonnage sizes. The WAPR11 may be installed horizontally or vertically in the room. Unit duct static requirements cannot be exceeded when using a sound plenum. Follow all instructions provided with the sound plenum when installing the product.

MIS-550 D

## Wiring – Main Power

# WARNING

### **Electrical shock hazard.**

**Do not operate this equipment without an earth ground attached and always disconnect the remote electric power supplies before servicing.**

**Electrical shock can result in serious injury or death.**

Main electrical power must be supplied to the unit from a clean, reliable power source. Verify voltage being supplied to the unit is consistent during all times of the day and within the range specified for the unit in the unit specifications and on the unit serial plate. Voltage must be measured at the field power connection point in the unit and while the unit is operating at full load (maximum amperage operating condition).

**NOTE:** *In applications where a field-supplied transformer is used to step down a higher incoming voltage, the center leg must be grounded when high resistance grounding is used.*

Refer to the unit serial plate and unit specifications for maximum fuse or circuit breaker size. Each outdoor unit is marked with a “Minimum Circuit Ampacity”. This means that the field wiring used must be sized

to carry that amount of current. Depending on the installed kW of electric heat, there may be two field power circuits required. If this is the case, the unit serial plate will so indicate.

All models are suitable only for connection with copper wire. Each unit and/or wiring diagram will be marked “Use Copper Conductors Only”. These instructions must be adhered to. Refer to the National Electrical Code (NEC) for complete current carrying capacity data on the various insulation grades of wiring material. All wiring must conform to NEC and all local codes.

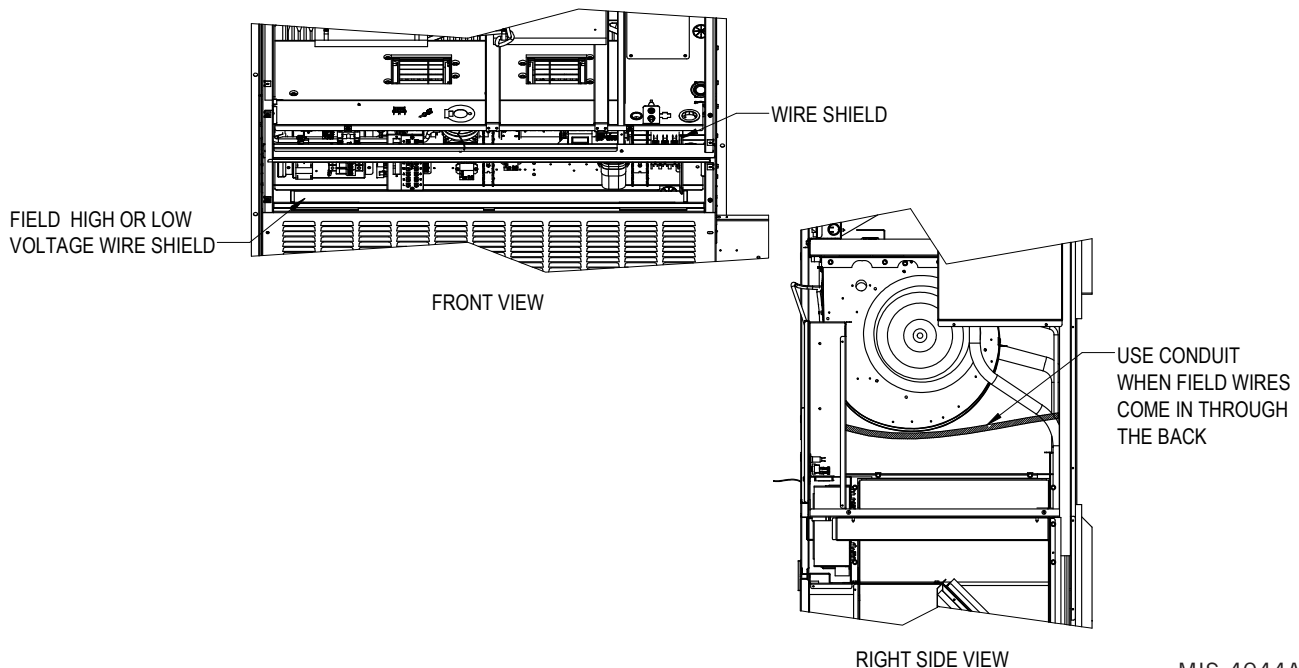
The electrical data on the serial plate, in the unit specifications and also in Table 11 on page 47 list fuse sizes for all models including the most commonly used heater sizes. Also shown are the number of field power circuits required for the various models with heaters. The unit rating plate lists a “Maximum Time Delay Relay Fuse” or circuit breaker that is to be used with the equipment. The correct type and size must be used for proper circuit protection and also to ensure that there will be no nuisance tripping due to the momentary high starting current of the compressor motor.

Three phase models must have proper phasing. A phase monitor is included in all three phase models, and will indicate improper phasing during a call for cooling (24VAC at Y1 terminal). See provided information included in this document regarding the phase monitor.

### **High Voltage Connections**

Route field wires under the field wire shield shown in Figure 19. (The field wire shield can be removed for wire installation.) If field power is supplied to the left

**FIGURE 19**  
**High Voltage Connections**



MIS-4044A

side of the unit, run the high voltage wires under the shield and to the right of the wire shield next to the compressor contactor and up into the upper control panel where the connections are made. If field power is supplied to the right of side of the unit, the low voltage wires can be run under the field wire shield to access the low voltage terminal strip.

When field wires are supplied through the back of the unit, flexible conduit must be extended through the back of the unit and terminate into the knock-outs on the upper control panel (see Figure 19).

### Wiring – Low Voltage

All 230/208V 1 phase and 3 phase equipment have dual primary voltage transformers. All equipment leaves the factory wired on 240V tap. For 208V operation, reconnect from 240V to 208V tap. The acceptable operating voltage range for the 240 and 208V taps are:

Tap: 240      Range: 253 – 216  
 Tap: 208      Range: 215 – 197

**NOTE:** *The voltage should be measured at the field power connection point in the unit and while the unit is operating at full load (maximum amperage operating condition).*

For low voltage wiring, an 18 gauge copper, color-coded cable is recommended. See Table 7 on page 29 for more information.

#### Low Voltage (24VAC) Connections

These units use a 24-volt AC low voltage circuit.

**C** terminal is the 24VAC common and is grounded.

**G** terminal is the indoor blower input.

**Y1** terminal is the 1st Stage input for cooling.

**Y2** terminal is the 2nd Stage compressor input for cooling and disables Balanced Climate mode if jumper is installed.

**Y3** If Y2-Y3 jumper is installed, Y2 terminal is the 2nd Stage compressor input for cooling. If the Y2-Y3 jumper is removed, Y3 will increase blower to rated airflow.

**B/W1** terminal is the 1st stage electric heat (if equipped).

**W2** terminal is the 2nd stage heat (if equipped).

**A** terminal is the ventilation input. This terminal energizes any powered factory-installed ventilation option and indoor blower.

**D** terminal is the dehumidification input. If installed, this terminal energizes any factory-installed dehumidification option.

**L** terminal is 24 volt alarm active output.

For units equipped with an alarm relay:

**1 terminal** is the normally closed contact on the relay.

**2 terminal** is the normally open contact on the relay.

**3 terminal** is the common contact on the relay.

See Table 3 for additional low voltage connections on auxiliary terminal strip.

**TABLE 3**  
**Additional Low Voltage Connections (if applicable)**

Terminal	Unit	Description
9	V Control Option Only	Discharge Air Sensor, 10K Ohm
10	V Control Option Only	Discharge Air Sensor, 10K Ohm
11	F, V Control Options	Filter Switch, Normally Open Contact
12	F, V Control Options	Filter Switch, Normally Open Contact
13	V Control Option Only	Blower Airflow Switch, Normally Open Contact
14	V Control Option Only	Blower Airflow Switch, Normally Open Contact
15	V Control Option Only	Compressor Current Sensor, Normally Open Contact
16	V Control Option Only	Compressor Current Sensor, Normally Open Contact

#### Unit Shutdown Feature (Standard on All Models)

The RT terminal is the 24VAC transformer output, and the R terminal is the 24VAC hot terminal for the operation of the equipment. RT and R are connected with a brass jumper bar which can be removed and RT and R connected to an external NC (normally closed) contact such as a fire/smoke detector that will cause shutdown of the equipment upon activation.

#### Balanced Climate™ Feature (Standard on All Models)

All units are equipped with the capability of running in Balanced Climate mode. This mode is designed to enhance the comfort level by reducing the indoor airflow amount and extending the run time to help extract more humidity during cooling operation. The Y2 terminal is the 24VAC input for Balanced Climate compressor cooling operation. The Y3 terminal is the 24VAC input for compressor cooling standard operation. Y2 and Y3 are connected with a brass jumper bar which can be removed to enable Balanced Climate mode. Units with an economizer will not have the brass jumper installed. Refer to vent manuals for instructions on how Balanced Climate works with each vent.

**NOTE:** *Units with mechanical dehumidification require an additional connection to be made when enabling Balanced Climate. Refer to dehumidification supplemental instructions for this step.*

To operate in Balanced Climate mode, a 3-stage cooling thermostat is required (no economizer with JADE controller can be installed). The lower indoor airflow operation is overridden by utilizing a 3-stage thermostat.

If the call for cooling is not satisfied within a given time frame or temperature differential (specified by the thermostat), the thermostat will send a signal to Y3 which then increases the blower speed back to the selected speed. See pages 48 – 49 for blower speed selection options.

**Refer to page 35 for additional Balanced Climate requirements and limitations.**

**Dehumidification Feature (Optional)**

The D terminal is the 24VAC input for dehumidification operation on dehumidification hot gas reheat equipped units. When 24VAC is applied to the D terminal, a 3-way valve solenoid is energized. The reheat coil located behind the evaporator coil is then active to reheat the supply air during cooling mode. This allows humidity to be removed from the air entering the unit without a large amount of sensible cooling capacity. During dehumidification, the indoor blower speed is reduced to help with the humidity removal. A humidity sensing thermostat or humidistat is required to control dehumidification operation.

**Ventilation Features (Optional)**

See ventilation instructions provided with unit for low voltage wiring.

**Low Ambient Control (LAC)**

The low ambient control is a pressure switch that is attached to the liquid line of the system and monitors high side pressure. Operation of the LAC occurs as outdoor temperatures drop below 60°F. LAC operation cycles the condenser fan on/off based on pressure changes caused by outdoor temperature changes.

**Outdoor Temperature Switch and Freeze Protection Thermostat**

An outdoor temperature switch and an evaporator freeze protection thermostat is supplied with all units that have a low ambient control. The outdoor switch disables Balanced Climate mode (if enabled) when the temperature drops below 50°F. This prevents potential evaporator coil freeze up issues. For units with mechanical dehumidification, this switch must remain disconnected when Balanced Climate mode is not being used. Refer to unit wiring diagram. The freeze thermostat cuts out compressor operation if the evaporator begins to freeze up.

**Alarm Relay Feature (Controls Option)**

The alarm relay provides a set of NO (normally open) and NC (normally closed) pilot duty contacts that operate when the compressor control module locks out compressor operation because of a high or low system refrigerant pressure event.

**DDC Controls Feature (Controls Option)**

The DDC controls option provides additional sensors that can be used with a field-supplied advanced logic

controller. The DDC controls option contains the following installed components:

**Dirty Filter Switch Indicator (DFS)**

The switch is adjustable and measures pressure drop across the unit filter surface. When pressure drop is higher than the switch setting, NO contacts are provided to indicate the filter needs to be serviced. Refer to page 49 for instructions on making switch adjustments.

**Discharge Air Sensor**

The discharge air sensor provides a temperature reading of the supply air leaving the unit. The sensor is a 10K OHM @ 77°F measuring device. It is installed in the supply airstream in the heater bracket.

**Airflow Switch**

The airflow switch measures the pressure differential between the blower inlet and outlet. It is located directly above the blower partition. Relay contacts (NO) are provided for the DDC controls option that indicates the indoor blower assembly needs to be serviced.

**Compressor Current Sensor**

The compressor current sensor indicates when the compressor is operational by measuring amp draw. It is located inside the unit control panel. Relay contacts (NO) are provided to indicate the compressor is not operating.

See Table 4 for low voltage connections for DDC control.

**TABLE 4  
Low Voltage Connections for DDC Control**

	Standard Units	Units w/ Economizers
Fan Only	Energize G	Energize G
1st Stage Cooling Mode/ Balanced Climate	Energize Y1, G	Energize Y1, G
2nd Stage Cooling Mode/ Balanced Climate	(Y2-Y3 jumper must be removed) Energize Y1, Y2, G	<i>Balanced Climate unavailable for units with economizers</i>
2nd Stage Cooling Mode/ Rated Airflow	(Y2, Y3 jumper must be removed) Energize Y1, Y2, Y3, G	Energize Y1, Y2, G
1st Stage Heating	Energize B/W1	Energize B/W1
2nd Stage Heating (if employed)	Energize B/W1, W2	Energize B/W1, W2
Ventilation	Energize A	Energize A
Dehumidification (if employed)	Energize D	Energize D

### Refrigerant Leak Detection System (RDS)

The RDS continuously monitors air in the indoor section of the unit for leaked refrigerant. In the event of a refrigerant leak, the RDS will initiate mitigation actions to disperse the refrigerant and prevent potentially dangerous refrigerant concentration levels. The RDS

will also provide a 24VAC alarm output signal on the "L" terminal of the unit low-voltage terminal strip.

Refer to page 40 for more information.

**TABLE 5  
Wall Thermostats**

Part Number	Predominate Features
8403-060 (1120-445)	3 stage Cool; 3 stage Heat; Electronic Programmable/Non-Programmable; HP or Conventional; Auto or Manual changeover; Dehumidification Output
8403-081 (BrightStat)	2 Stage Cool, 2 Stage Heat; Programmable/Non-Programmable Electronic; HP or Conventional; Auto or Manual Changeover with Humidity and Occupancy Sensor; BACnet; (Thermostat option only permissible for units up to 12 kW electric heat)
8403-083 (BrightStat)	2 Stage Cool, 2 Stage Heat; Programmable/Non-Programmable Electronic; HP or Conventional; Auto or Manual Changeover with Humidity (only); BACnet; (Thermostat option only permissible for units up to 12 kW electric heat)
8403-089 (T4 Pro)	1 stage Cool, 1 stage Heat – Heat Pump; 1 stage Cool, 1 stage Heat – Conventional; Programmable/Non-Programmable Electronic; Auto or Manual changeover
8403-090 (T6 Pro)	2 stage Cool, 3 stage Heat – Heat Pump; 2 stage Cool, 2 stage Heat – Conventional; Programmable/Non-Programmable Electronic; Auto or Manual changeover
8403-091	1 stage Cool, 1 stage Heat; Non-Programmable; FEMA use
8403-092 (T6 Pro Wi-Fi)	2 stage Cool, 3 stage Heat – Heat Pump; 2 stage Cool, 2 stage Heat – Conventional; Programmable/Non-Programmable Electronic; Auto or Manual changeover; Wi-Fi
8403-095 (T4 Pro)	1 stage Cool, 2 stage Heat – Heat Pump; 1 stage Cool, 1 stage Heat – Conventional; Programmable/Non-Programmable Electronic; Auto or Manual changeover

**TABLE 6  
CO<sub>2</sub> Controllers**

Part Number	Predominate Features
8403-096	Normally Open SPST relay closes-on-rise 24V dual wave length sensor. Default setting 950ppm, adjustable to 0-2000ppm Default off setting 1000ppm, adjustable to 0-200 ppm can be calibrated

**TABLE 7  
Thermostat Wire Size**

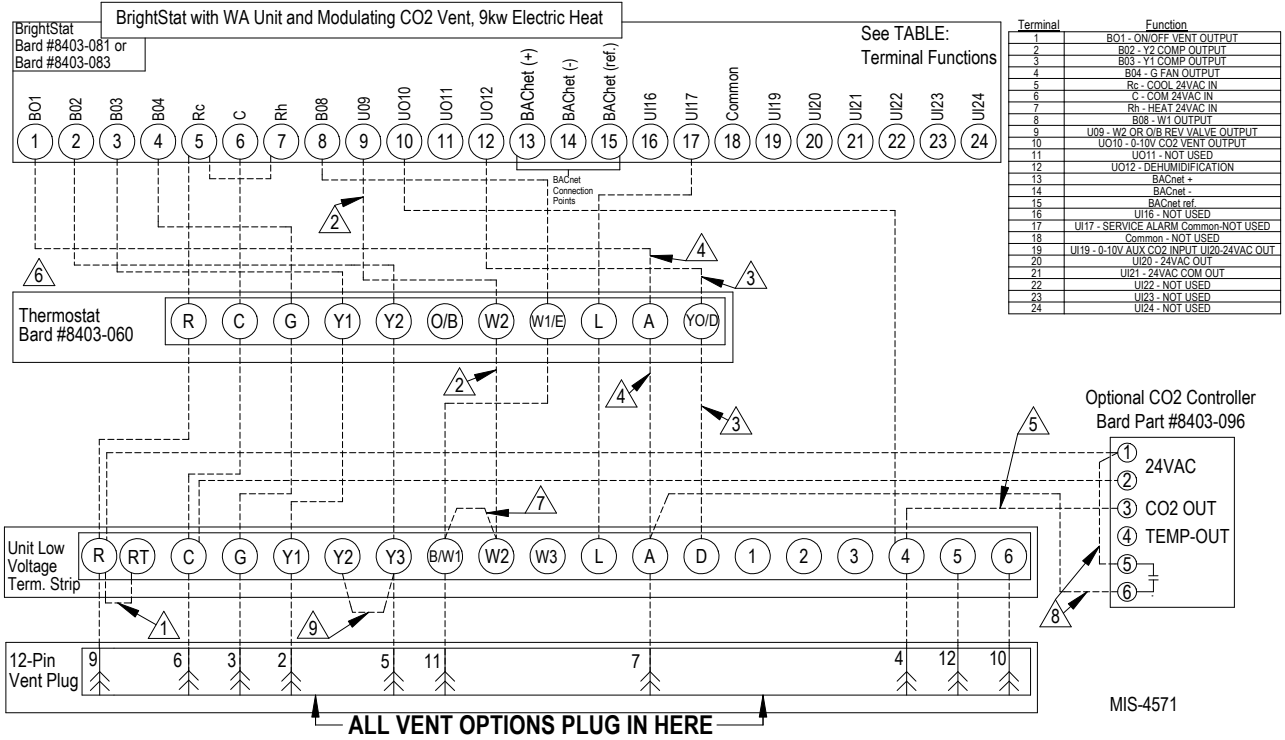
Transformer VA	FLA	Wire Gauge	Maximum Distance In Feet
55	2.3	18 gauge	60
		16 gauge	100
		14 gauge	160
		12 gauge	250

**TABLE 8  
Humidity Controls**

Part Number	Predominate Features
8403-100* (H6062A1000)	Electronic humidistat DPST Humidity range 10-90% with adjustable stops
8403-047 (H200-10-21-10)	Electronic dehumidistat SPST, closes-on-rise Humidity range 10-90% with adjustable stops

\* If using Honeywell HumidiPRO (H6062A1000) 8403-100 humidistat, it must be configured for dehumidification in the menu.

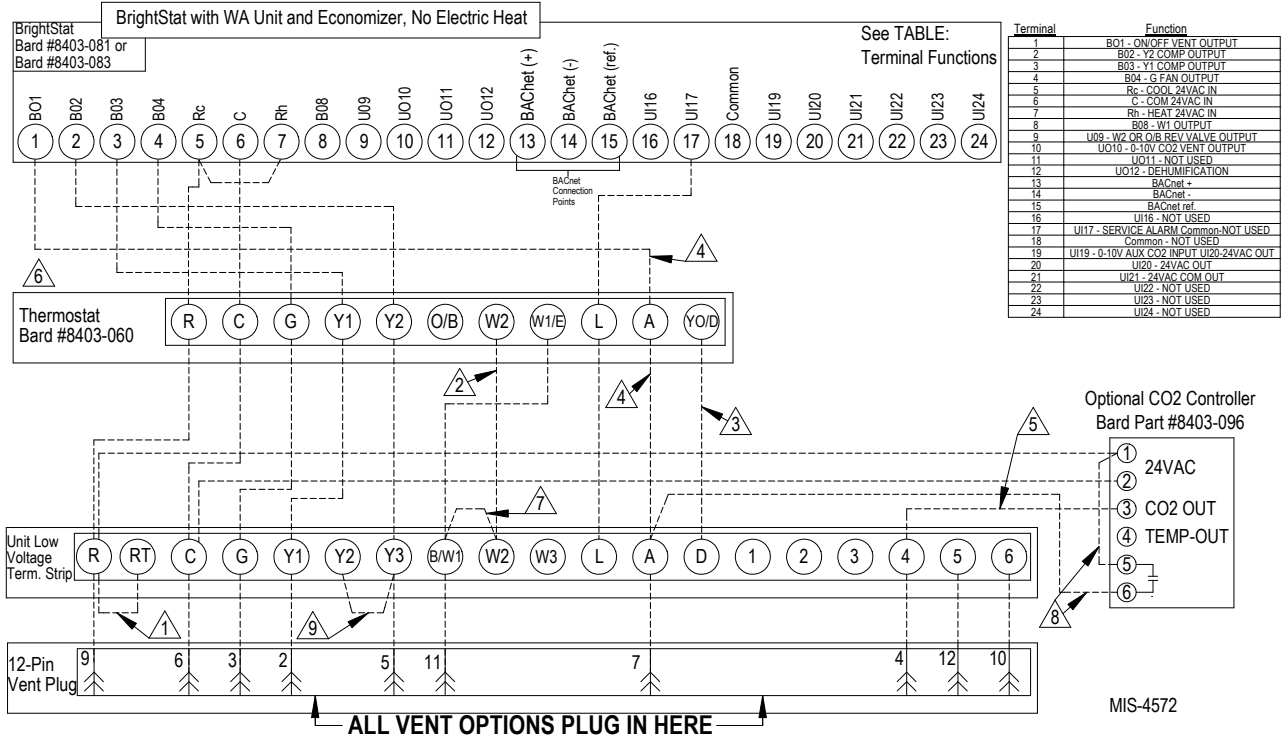
**FIGURE 20**  
**Programmable Thermostat Connections**



**ALL VENT OPTIONS PLUG IN HERE**  
*If not equipped with a ventilation option to plug in, a jumper plug must be installed.*

- ⚠️ Factory installed jumper. Remove jumper and connect to N.C fire alarm circuit if emergency shutdown required.
- ⚠️ Wire not needed below 15KW.
- ⚠️ Wire required for dehumidification models only.
- ⚠️ Do not connect "A" from thermostat if optional CO2 controller is used
- ⚠️ 0-10 VDC modulating CO2 control signal for modulating ventilation control (optional for ECON only - see vent instruction manuals)
- ⚠️ Change model configuration from heat pump to heat/cool. Must be configured to programmable and fan set to be programmed fan for the "A" output to function during scheduled occupied periods. Must be configured for multi-stage for Y1 output to be active 1st stage cooling. For dehumidification, must be configured for "No Economizer" for YO/D to be active for humidity control.
- ⚠️ Install jumper for 1 stage electric heat on units with more than 10KW
- ⚠️ Do not add these wires if setting up for modulating control. See note 5.
- ⚠️ Factory installed jumper. Remove jumper to activate Balanced Climate™ mode.
- ⚠️ A 3-stage thermostat is recommended for Balanced Climate mode. Must not be removed if econ is installed.

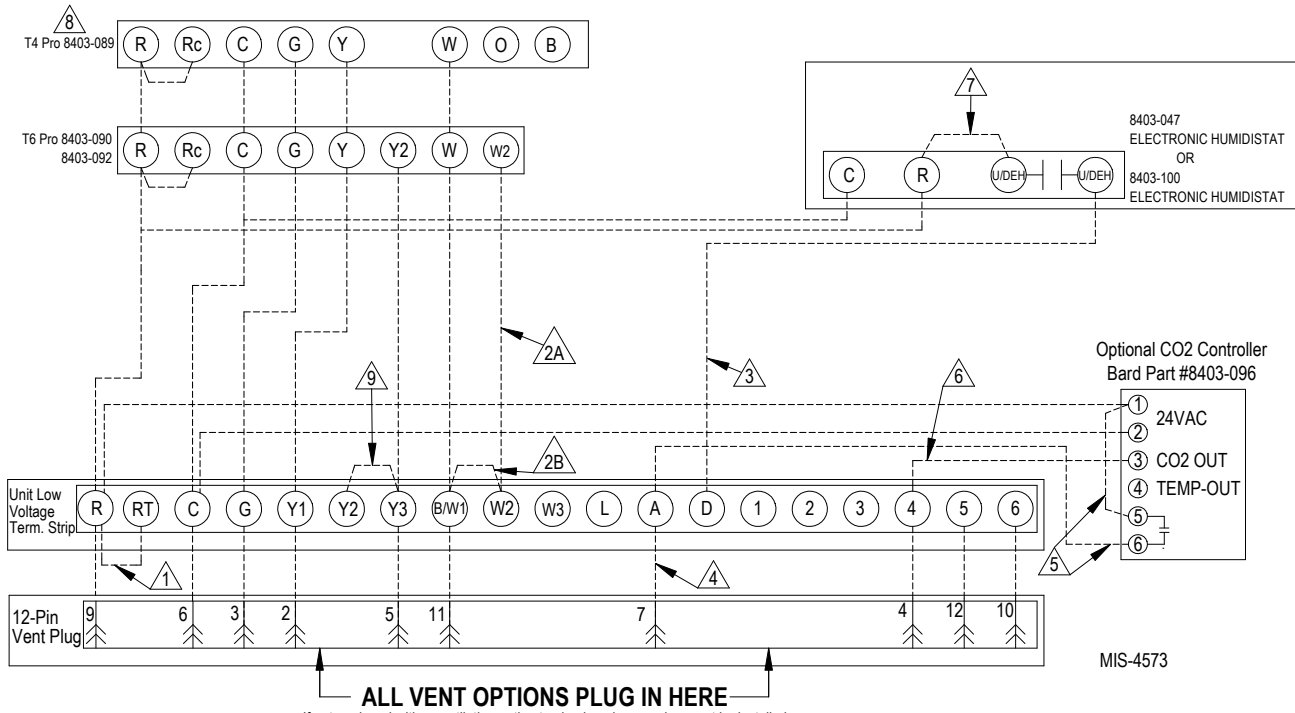
**FIGURE 21**  
**Programmable Thermostat Connections**



- ⚠️ 1 Factory installed jumper. Remove jumper and connect to N.C fire alarm circuit if emergency shutdown required.
- ⚠️ 2 Wire not needed below 15KW.
- ⚠️ 3 Wire required for dehumidification models only.
- ⚠️ 4 Do not connect "A" from thermostat if optional CO2 controller is used
- ⚠️ 5 0-10 VDC modulating CO2 control signal for modulating ventilation control (optional for ECON only - see vent instruction manuals)

- ⚠️ 6 Change model configuration from heat pump to heat/cool. Must be configured to programmable and fan set to be programmed fan for the "A" output to function during scheduled occupied periods. Must be configured for multi-stage for Y1 output to be active 1st stage cooling. For dehumidification, must be configured for "No Economizer" for YO/D to be active for humidity control.
- ⚠️ 7 Install jumper for 1 stage electric heat on units with more than 10KW
- ⚠️ 8 Do not add these wires if setting up for modulating control. See note 5.
- ⚠️ 9 Factory installed jumper. Remove jumper to activate balanced climate mode. A 3-stage thermostat is recommended for balanced climate mode. Must not be removed if econ is installed.

**FIGURE 22**  
**Non-Programmable Thermostat Connections**



MIS-4573

- |  |  |
|--|--|
| <p>⚠️ FACTORY INSTALLED JUMPER. REMOVE JUMPER AND CONNECT TO N.C FIRE ALARM CIRCUIT IF EMERGENCY SHUTDOWN REQUIRED.</p> <p>⚡️ WIRE NOT NEEDED BELOW 15KW.</p> <p>⚡️ INSTALL JUMPER FOR 1 STAGE ELECTRIC HEAT ON UNITS WITH MORE THAN 10KW.</p> <p>⚡️ WIRE REQUIRED FOR DEHUMIDIFICATION MODELS ONLY.</p> <p>⚠️ FOR VENT OPERATION, ADD JUMPER IF OPTIONAL CO2 CONTROLLER IS NOT USED. VENT WILL RUN WHILE BLOWER IS ENERGIZED. FOR ECON &amp; CRV-V AN ADDITIONAL WIRE CHANGE IS REQUIRED SEE INSTALL MANUAL.</p> <p>⚠️ DO NOT ADD THESE WIRES IF SETTING UP FOR MODULATING CONTROL. SEE NOTE 6.</p> | <p>⚡️ 0-10 VDC MODULATING CO2 CONTROL SIGNAL FOR MODULATING VENTILATION CONTROL (OPTIONAL FOR ECON ONLY) - SEE VENT INSTALLATION MANUAL.</p> <p>⚡️ JUMPER NEEDS ADDED.</p> <p>⚠️ THERMOSTAT WILL NOT WORK WITH UNITS EQUIPPED WITH ECONOMIZERS UNLESS CO2 CONTROLLER IS USED.</p> <p>⚡️ FACTORY INSTALLED JUMPER. REMOVE JUMPER TO ACTIVATE BALANCED CLIMATE™ MODE. A 3-STAGE THERMOSTAT IS RECOMMENDED FOR BALANCED CLIMATE MODE. MUST NOT BE REMOVED IF ECON IS INSTALLED.</p> <p>⚠️ HUMIDISTAT 8403-100 WILL NEED TO BE CONFIGURED FOR DEHUMIDIFICATION IN THE MENU. SEE USER'S MANUAL.</p> |
|--|--|

## NOTICE

These units require R-454B refrigerant and polyol ester oil.

### General

1. R-454B refrigerant is classified as an A2L, or mildly flammable refrigerant. Refer to A2L Refrigerant Safety Manual 2100-810 for information regarding safe practices for charging, reclaim, decommissioning and general handling of A2L refrigerants.
2. Use separate service equipment to avoid cross contamination of oil and refrigerants.
3. Use recovery equipment rated for R-454B refrigerant.
4. Use manifold gauges rated for R-454B (800 psi/250 psi low).
5. R-454B is a zeotropic blend of HFC-32 and HFO-1234yf. Charge with liquid refrigerant.
6. R-454B has an ozone depletion potential of zero, but must be reclaimed due to its global warming potential.
7. R-454B compressors use polyol ester oil.
8. Polyol ester oil is hygroscopic; it will rapidly absorb moisture and strongly hold this moisture in the oil.
9. A liquid line dryer must be used—even a deep vacuum will not separate moisture from the oil.
10. Limit atmospheric exposure to 15 minutes.
11. If compressor removal is necessary, always plug compressor immediately after removal. Purge with small amount of nitrogen when inserting plugs.

### Topping Off System Charge

If a leak has occurred in the system, Bard Manufacturing recommends reclaiming, evacuating (see manual 2100-810) and charging to the nameplate charge.

Since R-454B is a zeotropic blend, one component may leak off before another component in the event of a leak. This can cause significant changes to the concentration of each component in the system. For this reason, Bard Manufacturing does not recommend topping off the system charge.

**REMEMBER:** When adding R-454B refrigerant, it must come out of the charging cylinder/tank as a liquid to avoid any fractionation, and to ensure optimal system performance. Refer to instructions for the cylinder that is being utilized for proper method of liquid extraction.

## WARNING

**Failure to conform to these practices could lead to damage, injury or death.**

### Safety Practices

1. Never mix R-454B with other refrigerants.
2. Use gloves and safety glasses. Polyol ester oils can be irritating to the skin, and liquid refrigerant will freeze the skin.
3. Never use air and R-454B to leak check; the mixture is flammable.
4. Do not inhale R-454B—the vapor attacks the nervous system, creating dizziness, loss of coordination and slurred speech. Cardiac irregularities, unconsciousness and ultimate death can result from breathing this concentration.
5. Do not burn R-454B. This decomposition produces hazardous vapors. Evacuate the area if exposed.
6. Use only cylinders rated DOT4BA/4BW 400.
7. Never fill cylinders over 80% of total capacity.
8. Store cylinders in a cool area, out of direct sunlight.
9. Never heat cylinders above 125°F.
10. Never trap liquid R-454B in manifold sets, gauge lines or cylinders. R-454B expands significantly at warmer temperatures. Once a cylinder or line is full of liquid, any further rise in temperature will cause it to burst.

### Important Installer Note

For improved start up performance, wash the indoor coil with a dishwashing detergent.

### High Pressure Switch

All W\*\*AF wall-mounted air conditioner series models are supplied with a remote reset for the high pressure switch. If tripped, the pressure switch may be reset by turning the thermostat off then back on again. High pressure switch settings: Opens 615 +/- 15 PSI, Closes 490 +/- 15 PSI.

## Three Phase Scroll Compressor Start Up Information

Scroll compressors, like several other types of compressors, will only compress in one rotational direction. Upon start up, direction of rotation is not an issue with single phase compressors since they will always start and run in the proper direction.

However, three phase compressors will rotate in either direction depending upon phasing of the power. Since there is a 50-50 chance of connecting power in such a way as to cause rotation in the reverse direction, verification of proper rotation must be made. Verification of proper rotation direction is made by observing that suction pressure drops and discharge pressure rises when the compressor is energized. Reverse rotation also results in an elevated sound level over that with correct rotation, as well as substantially reduced current draw compared to tabulated values.

Verification of *proper rotation* must be made at the time the equipment is put into service. If improper rotation is corrected at this time, there will be no negative impact on the durability of the compressor. However, reverse operation for over 1 hour may have a negative impact on the bearing due to oil pump out.

**NOTE:** *If compressor is allowed to run in reverse rotation for an extended period of time, the compressor's internal protector will trip.*

All three phase compressors are wired identically internally. As a result, once the correct phasing is determined for a specific system or installation, connecting properly phased power leads to the same Fusite terminal should maintain proper rotation direction.

The direction of rotation of the compressor may be changed by reversing any two line connections to unit.

## Phase Monitor

All units with three phase scroll compressors are equipped with a three phase line monitor to prevent compressor damage due to phase reversal.

The phase monitor in this unit is equipped with two LEDs. If the Y signal (call for cooling) is present at the phase monitor and phases are correct, the green LED will light.

If phases are reversed, the red fault LED will be lit and compressor operation is inhibited.

If a fault condition occurs, reverse two of the supply leads to the unit. **Do not reverse any of the unit factory wires as damage may occur.**

## Condenser Fan Operation

**NOTE:** *Certain models may be equipped with a low ambient control (LAC), and if so, the condenser fan motor will have a delayed start until system refrigerant operating pressure builds up. After*

*starting, the fan motor may or may not cycle depending upon ambient conditions. This is normal operation.*

50 Hz models must have fan wired on low speed. These models are factory wired on low speed.

## Service Hints

1. Caution owner/operator to maintain clean air filters at all times and also not to needlessly close off supply and return air registers. This reduces airflow through the system, which shortens equipment service life as well as increasing operating costs.
2. Check all power fuses or circuit breakers to be sure they are the correct rating.
3. Periodic cleaning of the outdoor coil to permit full and unrestricted airflow circulation is essential.

## Sequence of Operation

### Cooling

#### No Economizer

Stage 1: (Y1) cooling call activates Step 1 (partial capacity, 66%) of compressor capacity.

Stage 2: (Y2) cooling call activates Step 2 (full capacity, 100%) of compressor capacity. (Jumper installed)

Stage 2 Balanced Climate: 3 stage thermostat required. Y2-Y3 jumper must be removed. (Y1, Y2) cooling call activates Step 2 (full capacity, 100%) of compressor capacity and Balanced Climate mode.

#### With Economizer

Stage 1 (Y1) cooling call goes to economizer controls for decision:

- If enthalpy control decides outdoor conditions are suitable for free cooling, the economizer will operate.
  - If Stage 2 cooling call is issued during economizer operation, the economizer will close and the compressor will go straight to Step 2 full capacity operation.
- If enthalpy control decides outdoor conditions are not suitable for free cooling, the economizer will not operate (or close) and Step 1 of the compressor will operate.
  - If Stage 2 cooling call is issued, the compressor will shift to Step 2 full cooling capacity operation.

(See **NOTE** under **Condenser Fan Operation** concerning models equipped with low ambient control.)

The G (indoor motor) circuit is automatically completed by the thermostat on any call for cooling operation or can be energized by manual fan switch on subbase for constant air circulation. On a call for heating, circuit

R-W1 makes at the thermostat pulling in heat contactor for the strip heat and blower operation. On a call for second stage heat, R-W2 makes bringing on second heat contactor, if so equipped.

### Balanced Climate™ Mode

Balanced Climate™ is a great comfort feature that can easily be applied under any normal circumstances. If the Bard air conditioning system is being set up in a typical environment where 72°F is the lowest cooling setpoint, remove the Y2/Y3 jumper and install a 3-stage cooling thermostat (no economizer with JADE controller can be installed). This will increase the humidity removal up to 35% and provide a much more comfortable environment.

**NOTE:** Units with mechanical dehumidification require an additional connection to be made when enabling Balanced Climate. Refer to dehumidification supplemental instructions for this step.

**If the application is likely to require air conditioning operation below 60°F outdoor conditions, a low ambient control (LAC) kit must be installed.** The LAC kit is equipped with an outdoor temperature switch that disables Balanced Climate mode when the outdoor temperature drops below 50°F. This prevents potential evaporator coil freeze up issues. The LAC kit also comes with an evaporator freeze protection thermostat that cuts out the compressor if the evaporator begins to freeze up.

**If the unit is being installed with any ventilation package, a Bard LAC kit must be installed.** Failure to utilize an LAC with any air conditioner can cause coil freeze up.

Balanced Climate can readily be applied to duct-free (supply and return air grille) applications. It may also be applied to ducted applications with **limited static of 0.20" ESP (total including both supply and return statics)**. Consult Bard Application Engineering for details prior to implementation.

**CAUTION:** *Balanced Climate is not a replacement for a dehumidification (hot gas reheat) unit for extreme applications, but rather an enhancement feature for limited climates and applications.*

### Vent Connection Plug

All units are equipped with a vent connection plug in the side of the control panel for the different ventilation packages to plug in to. If the compressor will not start and there is no "Y1" at the compressor control module, first check to make sure that either the optional vent is plugged into the vent connection plug or the supplied jumper plug is in place. **The unit will not operate without anything plugged in.** This plug is located on the side of the control panel behind the front vent door (behind the filter access door). If the unit is supplied with a factory-installed vent package, it will be plugged in but the jumper plug will also be tethered next to the connection for troubleshooting purposes, if necessary.

## Compressor Control Module

The compressor control module (CCM) is standard on all models covered by this manual.

### Features

Delay-on-Make Timer  
Short Cycle Protection/Delay-on-Break  
Low Pressure Detection  
High Pressure Detection  
LPC and HPC Status LEDs  
Test Mode  
Brownout Protection with Adjustment

### Delay-on-Make Timer

A delay-on-make timer is included to be able to delay startup of the compressor. This is desired when more than one unit is on a structure so that all of the units do not start at the same time which could happen after a power loss or building shutdown. The delay-on-make time period is 2 minutes plus 10% of the delay-on-break time period. To ensure that all of the units do not start at the same time, adjust the delay-on-break timer on each unit to a slightly different delay time.

### Short Cycle Protection/Delay-on-Break

An anti-short cycle timer is included to prevent short cycling the compressor. This is adjustable from 30 seconds to 5 minutes via the adjustment knob (see Figure 23 on page 36). Once a compressor call is lost, the time period must expire before a new call will be initiated.

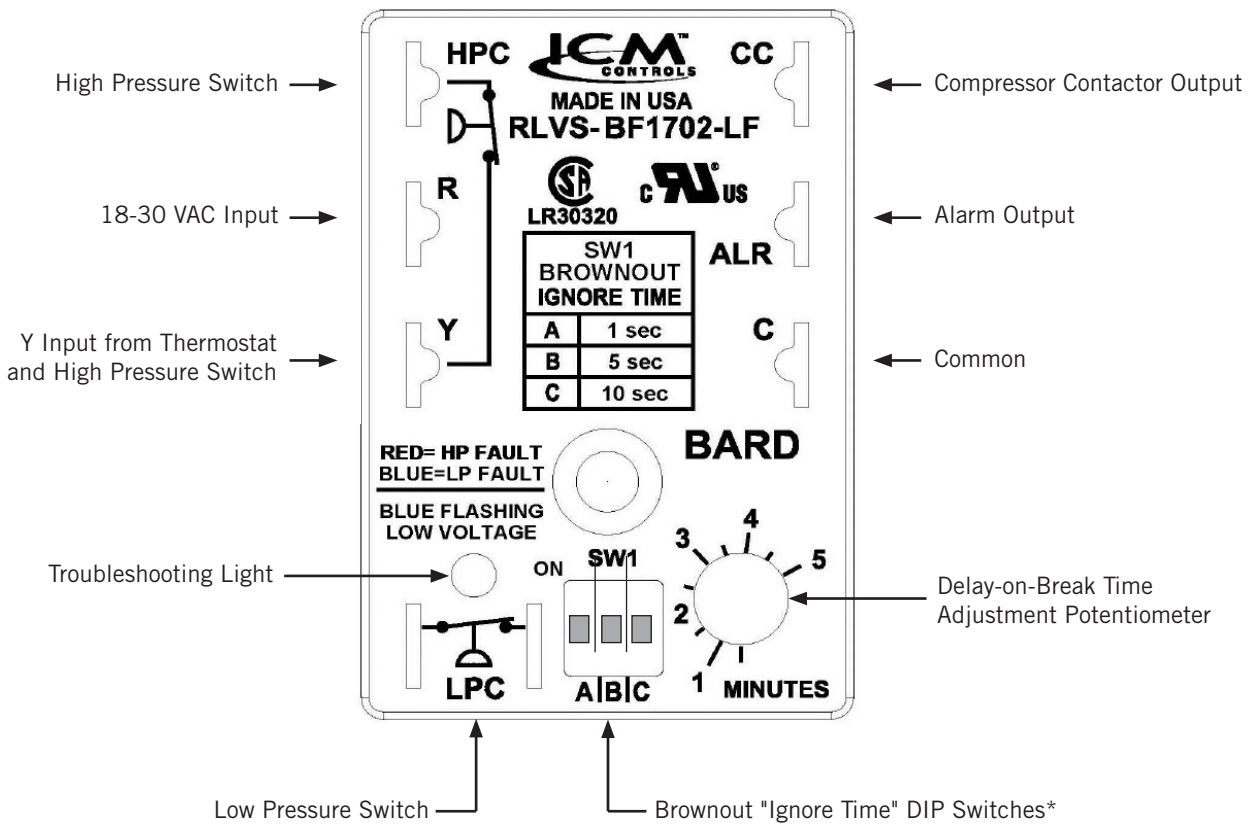
### Low Pressure Detection

Low pressure switch monitoring allows for a lockout condition in a situation where the switch is open. If the low pressure switch remains open for more than 2 minutes, the CCM will de-energize the compressor for the delay-on-break time. If the switch closes again, it will then restart the compressor. If the switch trips again during the same Y call, the compressor will be de-energized and the alarm terminal will be energized indicating an alarm. The blue LED will light and stay on until power is cycled to the control or a loss of voltage is present at Y terminal for more than ½ second.

### High Pressure Detection

High pressure switch monitoring allows for a lockout condition in a situation where the switch is open. If the high pressure switch opens, the CCM will de-energize the compressor. If the switch closes again, it will then restart the compressor after the delay-on-break setting has expired on the device. If the switch trips again during the same thermostat call, the compressor will be de-energized and the alarm terminal will be energized indicating an alarm. The red LED will light and stay on until power is cycled to the control or a loss of voltage is present at Y terminal for more than ½ second.

**FIGURE 23**  
**Compressor Control Module**



\* Turn on only one switch for that specific "Ignore Time" setting. 10 seconds is the maximum brownout "Ignore Time". If all switches are "off", the control is in "do not ignore".

**Test Mode**

By rapidly rotating the potentiometer (POT) clockwise (see Figure 23), all timing functions will be removed for testing.

The conditions needed for the unit to enter test mode are as follows: POT must start at a time less than or equal to the 40 second mark. The POT must then be rapidly rotated to a position greater than or equal to the 280 second mark in less than 1/4 second. Normal operation will resume after power is reset or after the unit has been in test mode for at least 5 minutes.

**Brownout Protection with Adjustment**

Brownout protection may be necessary if the utility power or generator power has inadequate power to prevent the voltage from dropping when the compressor starts. This is rare but can happen if the generator is undersized at the site or if the site is in a remote location far from the main power grid. Under normal circumstances, allowing the brownout to be ignored for a time period should not be needed. The CCM is shipped with all the DIP switches in the 'off' or 'do not ignore' position (see Figure 23).

If ignoring the brownout is needed because of the above conditions, three preset timers can be set by DIP switches in order to delay signaling a power brownout for a specific length of time after compressor contactor is energized.

This allows the compressor a time period to start even if the voltage has dropped and allows the voltage to recover. This delay only happens when the CC terminal energizes. The delay can be set to 1 second ("A" DIP switch), 5 seconds ("B" DIP switch) or 10 seconds ("C" DIP switch); time is not cumulative—only the longest setting will apply. If the voltage recovers during the brownout delay period, the compressor will continue running.

If a brownout condition is detected by the CCM at any point while there is a cooling call or power is on at Y, the troubleshooting light will flash blue. The light will continue to flash until the cooling call is satisfied or power is removed from the Y terminal. This condition does not prevent operation; it only indicates that a brownout condition was present at some point during the call. If a brownout condition is detected while CC has an output, CC will be de-energized and will retry after the delay-on-break timer is satisfied, honoring any DIP switch timer chosen when the CC output is re-energized; this process will continue until call is satisfied.

If inadequate utility or generator power continues after the delay-on-make or delay-on-break timer is fulfilled, the CC output will not energize. This could lead to the compressor never starting. The control will see the brownout immediately and not start.

A common scenario and one that has been seen in the field is when a unit or units switch from utility power to generator power. With slower transfer switches, the time delay between utility power and generator power didn't cause a problem. The units lost power, shut off and came back on line normally. With the introduction of almost instantaneous transfer switches, the power glitch may be enough that the compressor will start to run backwards.

## **Pressure Service Ports**

High and low pressure service ports are installed on all units so that the system operating pressures can be observed. Pressure tables covering all models can be found on pages 45 and 46. It is imperative to match the correct pressure table to the unit by model number.

This unit employs high-flow Coremax valves instead of the typical Schrader-type valves.

***WARNING! Do NOT use a Schrader valve core removal tool with these valves. Use of such a tool could result in eye injuries or refrigerant burns!***

To change a Coremax valve without first removing the refrigerant, a special tool is required which can be obtained at [www.fastestinc.com/en/SCCA07H](http://www.fastestinc.com/en/SCCA07H). See the replacement parts manual for replacement core part numbers.

# SERVICE

## Troubleshooting Nidec SelecTech Series ECM Motors

### If the Motor Is Running

1. It is normal for the motor to rock back and forth on start up. Do not replace the motor if this is the only problem identified.
2. If the system is excessively noisy, does not appear to change speeds in response to a demand (Heat, Cool, Other) or is having symptoms during the cycle such as tripping limit or freezing coil, check the following:
  - A. Wait for programmed delays to time out.
  - B. Ensure that the motors control inputs are wired as shown in the factory-supplied wiring diagram to ensure motor is getting proper control signals and sequencing.
  - C. Remove the filter and check that all dampers, registers and grilles are open and free flowing. If removing the filters corrects the problem, clean or replace with a less restrictive filter. Also check and clean the blower wheel or coil as necessary.
  - D. Check the external static pressure (total of both supply and return) to ensure it is within the range as listed on the unit serial plate. If higher than allowed, additional duct work is needed.
  - E. If the motor does not shut off at the end of the cycle, wait for any programmed delays to time out (no more than 90 seconds). Also make

sure that there is no call for “Continuous Fan” on the G terminal.

- F. If the above diagnostics do not solve the problem, confirm the voltage checks in the next section below, then continue with the **Model SelecTech Communication Diagnostics**.

### If the Motor Is Not Running

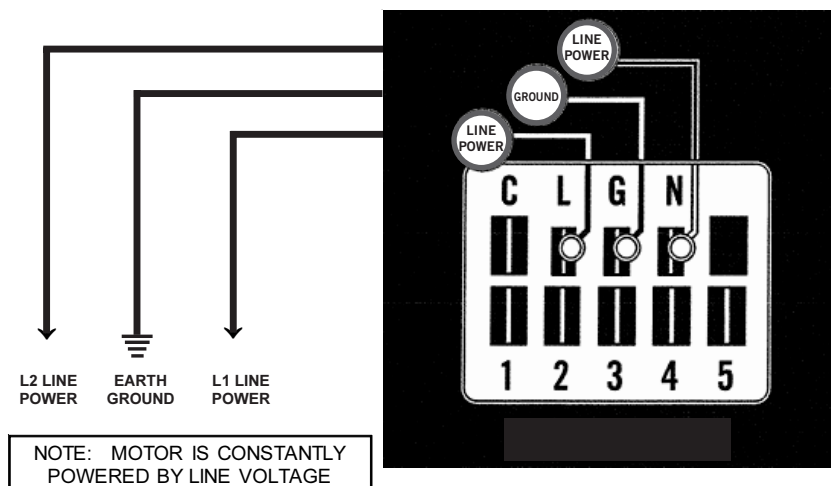
1. Check for proper high voltage and ground at the L/ L1, G, N/L2 connections at the motor (see Figure 24). Correct any voltage issues before proceeding to the next step. The SelecTech motor is voltage specific. Only the correct voltage should be applied to the proper motor. Input voltage within plus or minus 10% of the nominal line power VAC is acceptable.
2. If the motor has proper high voltage and ground at the L/L1, G, N/L2 connections, then continue with the **Model SelecTech Communication Diagnostics**.

### Model SelecTech Communication Diagnostics

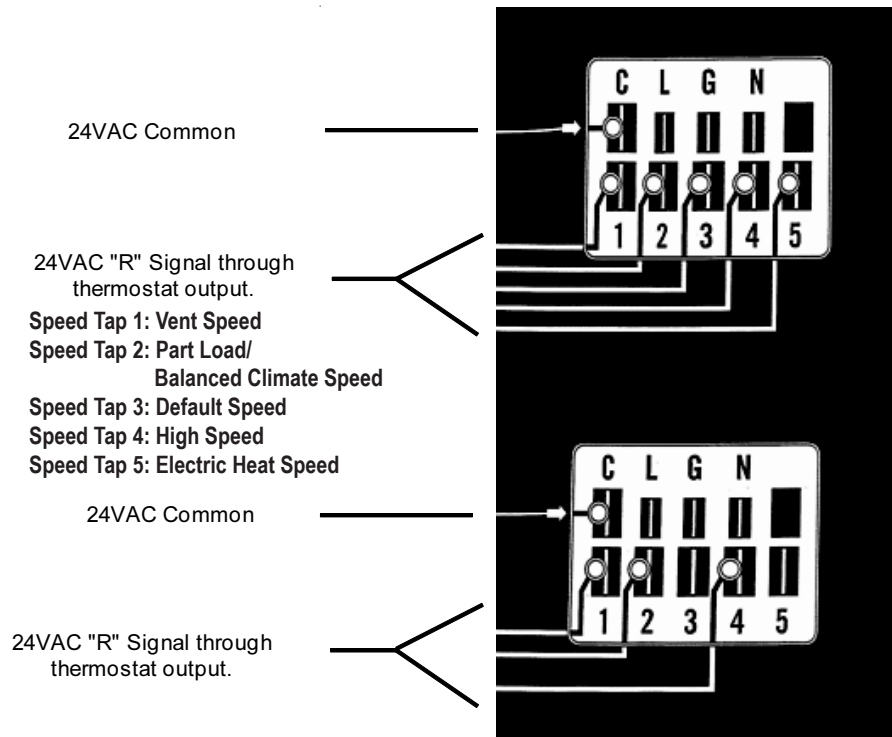
The SelecTech motor is communicated through 24 VAC low voltage (thermostat control circuit wiring).

1. Start with unit wiring diagram to confirm proper connections and voltage (see Figure 25 on page 38).
2. Initiate a demand from the thermostat and check the voltage between the common and the appropriate motor terminal (1-5). (G input is typically on terminal #1, but always refer to wiring diagram.)
  - A. If the low voltage communication is not present, check the demand from the thermostat. Also check the output terminal

**FIGURE 24**  
**Motor Connections**



**FIGURE 25**  
**Motor Connections**



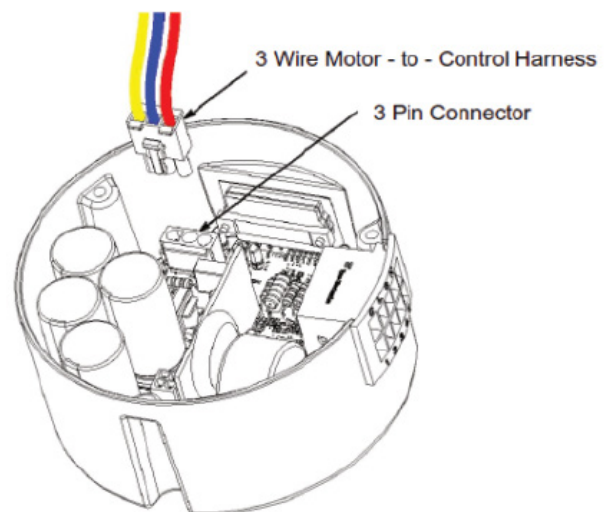
and wire(s) from the terminal strip or control relay(s) to the motor.

- B. If the motor has proper high voltage as identified above (**If the Motor Is Not Running Step 1**), proper low voltage to a programmed terminal and is not operating, next check resistances at the motor lead plug.
3. Disconnect power from the motor. Remove the motor control module from the blower assemblies mounting plate to access the back plate of the control module. Then remove the back plate and unplug the motors plug from the control module (see Figure 26).
  4. The control module is now completely detached from the motor. Verify with a standard ohmmeter the motors winding resistance:
    - A. Measure that there is resistance between pins 1 to 2, 1 to 3 and 2 to 3. The readings should not be 0 ohms and all three measurements should be within  $\pm 10\%$  of each other. Move to step B if the windings resistance are within range. **If any motor lead fails this test, the motor is defective and must be replaced.**
    - B. Test that each lead to the motor shell is  $>100K$  ohms (see Figure 25). (Take measurement to unpainted motor end plate.)

**If any motor lead fails this test, the motor is defective and must be replaced.**

**NOTE:** *Installing the new control module will cause it to fail also.*

**FIGURE 26**  
**Motor Control Module**



## Refrigerant Leak Detection System (RDS)

This unit is equipped with a refrigerant leak detection system (RDS). This system monitors the air in the indoor section of the unit for refrigerant leaks. In the event of a leak, the RDS will enter mitigation mode, which prohibits function of the compressor and electric heaters (if applicable) and turns on the indoor blower in order to prevent the refrigerant from concentrating within the unit. The RDS is made up of three major components: Refrigerant sensor, RDS harness and DPDT relay (see Figure 27).

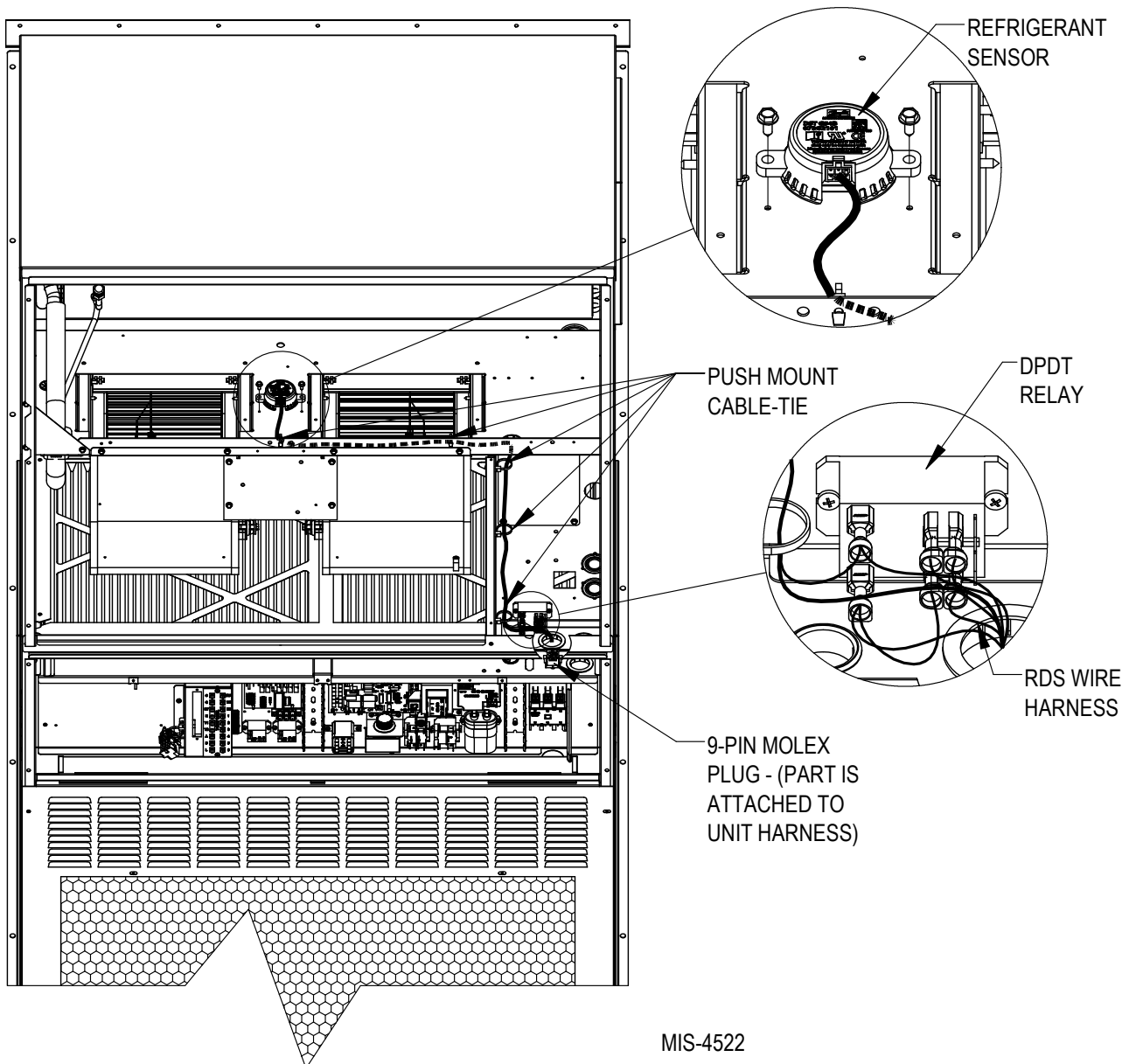
### Why RDS?

R-454B refrigerant carries an "A2L" safety classification, meaning it is mildly flammable in certain concentrations. The purpose of the RDS is to prevent refrigerant from reaching potentially dangerous concentrations within the indoor section of the unit in the event of a refrigerant leak.

### Sequence of Operations

The refrigerant sensor has four operating modes: Power up and self test, normal, alarm state and sensor fault. During all modes of operation the sensor will continue to perform runtime diagnostics.

**FIGURE 27**  
**Refrigerant Leak Detection System**



MIS-4522

### Power Up and Self Test

When the unit receives power, the refrigerant sensor executes a series of self test diagnostics. This validates the integrity of the sensor's memory, embedded program, and power supply. This power up sequence only takes a few seconds.

### Normal Operation

Once the refrigerant sensor's power up sequence is complete, the RDS begins normal operation. In this mode the refrigerant sensor is active and the air conditioner functions normally.

### Alarm State

The refrigerant sensor has a factory-set alarm threshold limit value. When the sensor registers refrigerant at a concentration above this threshold, the sensor enters alarm state. In alarm state the internal relay within the refrigerant sensor is de-energized, which puts the RDS into mitigation mode.

### Sensor Fault Mode

The refrigerant sensor performs continuous diagnostics on the sensor integrity (shorts, opens, out of range, communication errors) as well as the integrity of the on-board memory, programming, oscillator and voltage levels. If any of these diagnostics fail or the sensor becomes disconnected, the internal relay within the refrigerant sensor is de-energized, which puts the RDS into mitigation mode.

### Mitigation Mode

When the RDS enters mitigation mode, it initiates the following:

- The "G" terminal is energized on the low voltage terminal strip. This activates the indoor blower.
- The signal from "CC" on the compressor control module to the compressor contactor is interrupted. This stops compressor operation and prevents it from starting in the event of a call from the thermostat.
- The 24V common connection to all electric heat contactors (if applicable) is broken. This stops electric heat operation and prevents it from starting in the event of a heating call.
- The "L" terminal on the low voltage terminal strip is energized. This output may be used to trigger an external alarm or notify a building management system or thermostat that a leak has occurred.

### Alarm Reset

The refrigerant sensor will stay in alarm mode as long as the refrigerant concentration remains above the alarm threshold limit value. For the alarm to be reset, the sensor reading must be a minimum of 2.5% below the alarm threshold for a period of 5 minutes. The relay is then re-energized, and the unit returns to normal operation.

### RDS Diagnosis

The refrigerant sensor of the RDS features a status LED. When the sensor is powered up, an LED will indicate sensor status. The sensor LED will back-light the sensor and create a visible reflection on the blower partition. Status LED blink codes shown in Figure 28.

**NOTE:** *If the sensor status LED is not lit, the sensor is either not receiving power or may be faulty or damaged. Check harness connections and test internal relay. Refer to A2L Safety Manual 2100-810 for additional diagnostic information.*

**FIGURE 28**  
**Sensor Status LED Blink Code**

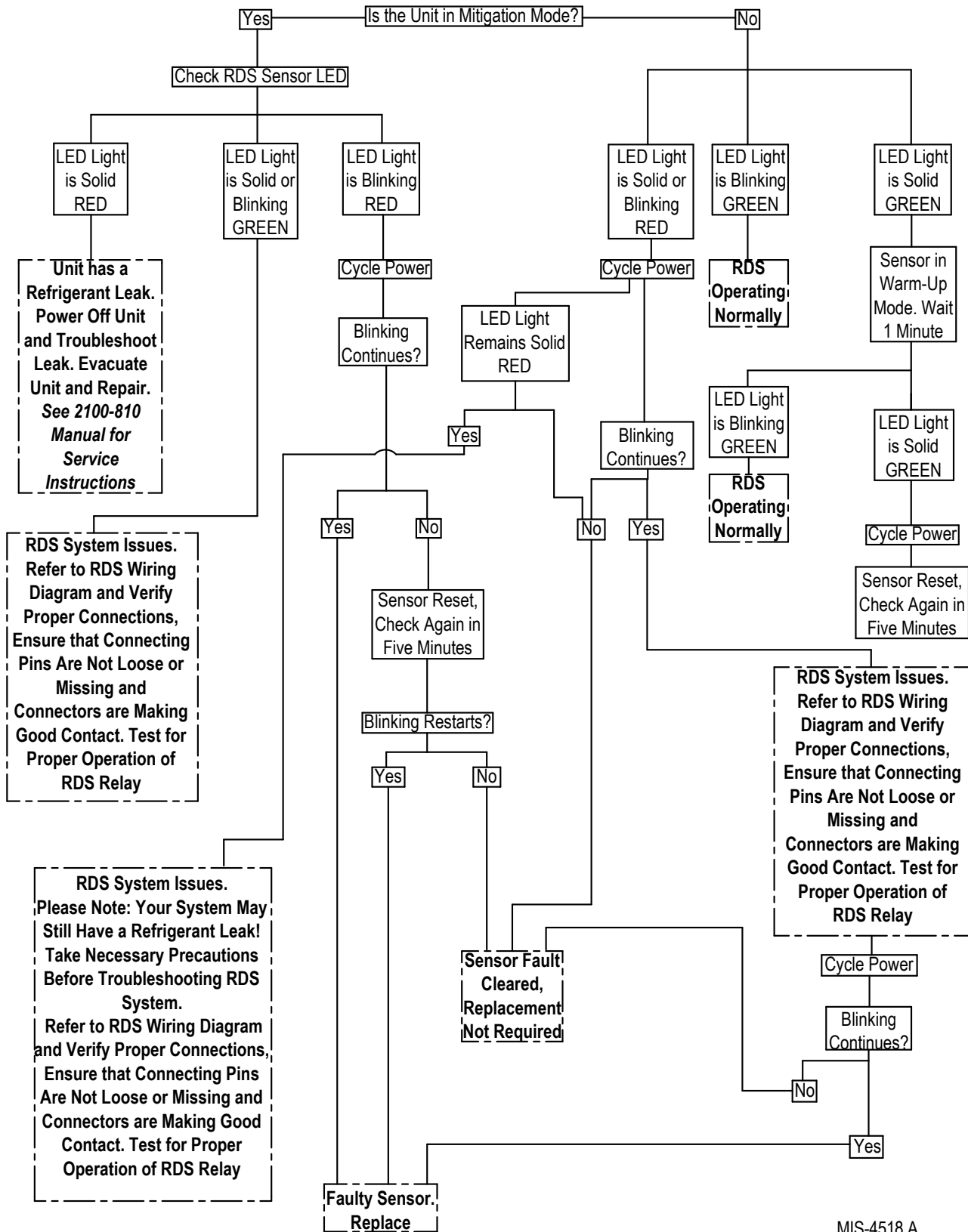
- Solid Green: Sensor Power Up and Self Test
- — — Blinking Green: Normal Operation
- Solid Red: Alarm State – Gas Detection
- — — Blinking Red: Sensor Fault



### Sensor End-of-Life

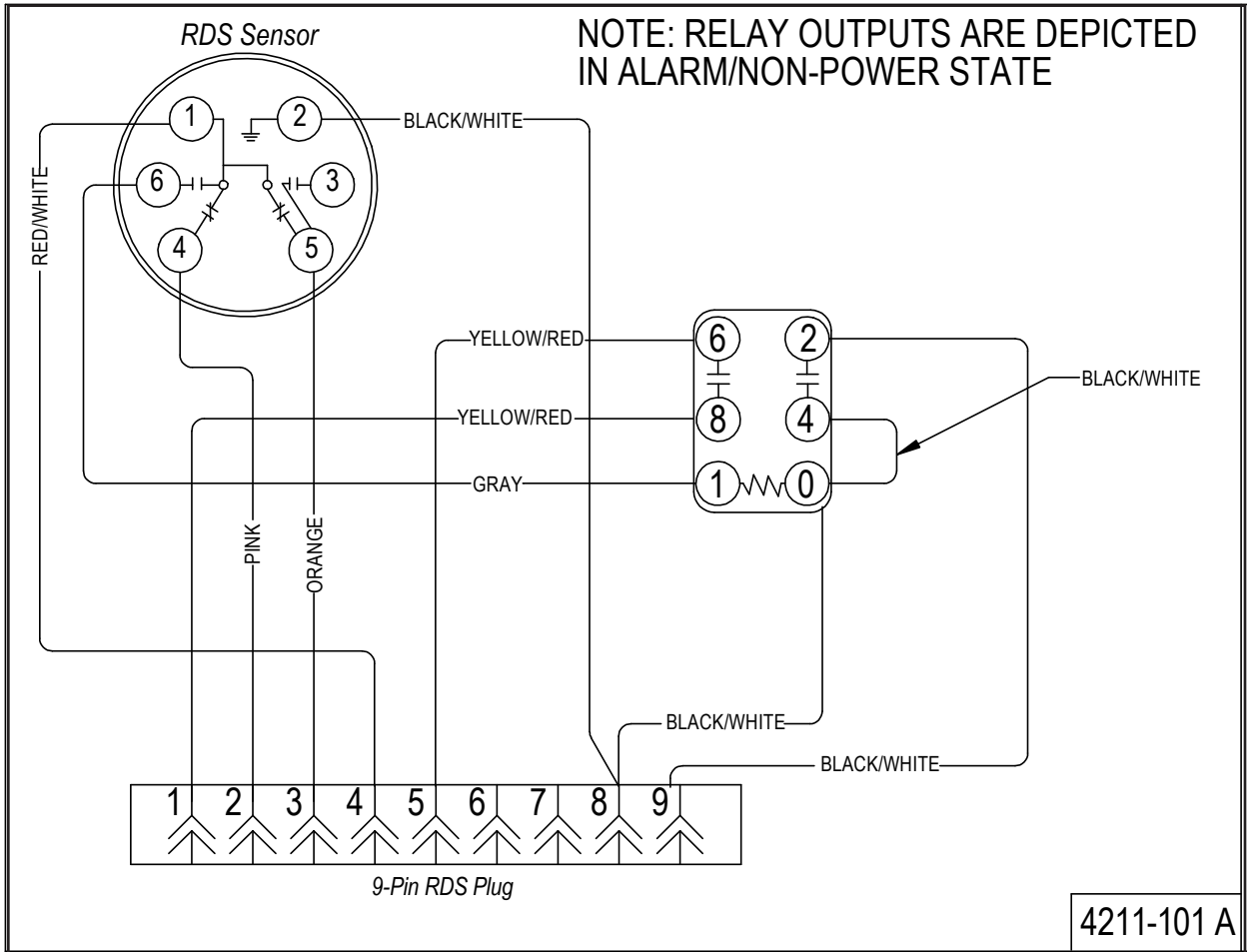
The refrigerant sensor has a rated life expectancy of 15+ years. This is not a set time length, but it is the expected time that the sensor should last without failing its internal checks. In the event that the sensor would reach its end-of-life, it will enter Sensor Failure Mode and the sensor will need to be replaced. **The sensor must be replaced with a Bard-approved refrigerant sensor.** See unit replacement parts manual for the correct replacement sensor information.

**FIGURE 29**  
**Refrigerant Leak Detection System (RDS) Troubleshooting**



MIS-4518 A

**FIGURE 30**  
**Refrigerant Leak Detection System (RDS) Wiring Diagram**

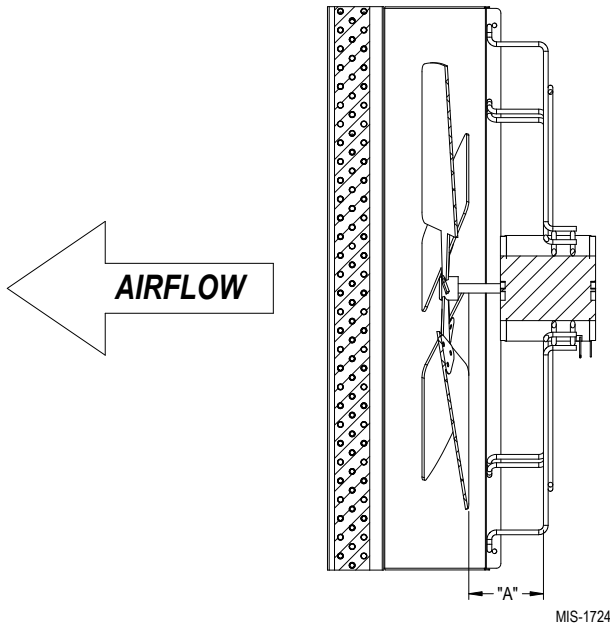


## Fan Blade Setting Dimensions

Shown in Figure 31 is the correct fan blade setting for proper air delivery across the outdoor coil. Refer to Table 9 for unit specific dimension.

Any service work requiring removal or adjustment in the fan and/or motor area will require that the dimensions below be checked and blade adjusted in or out on the motor shaft accordingly.

**FIGURE 31**  
Fan Blade Setting



MIS-1724

**TABLE 9**  
Fan Blade Dimensions

Model	Dimension A*
W3SAF W4SAF	1.5"
W5SAF	1.75"

\* "A" dimension is measured at the closest part of the fan blade

## R-454B Refrigerant Charge

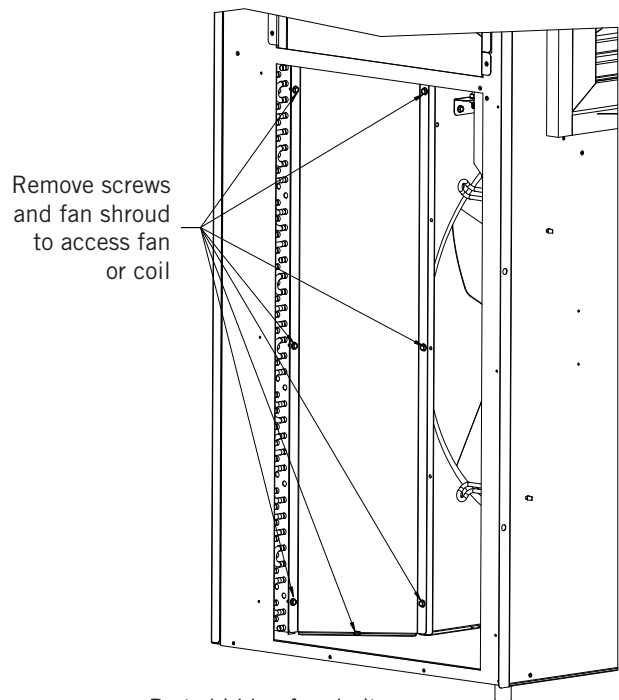
This unit was charged at the factory with the quantity of refrigerant listed on the serial plate. AHRI capacity and efficiency ratings were determined by testing with this refrigerant charge quantity.

The pressure tables on the following pages show nominal pressures for the units. Since many installation specific situations can affect the pressure readings, this information should only be used by certified technicians as a guide for evaluating proper system performance. They shall not be used to adjust charge. If charge is in doubt, reclaim, evacuate and recharge the unit to the serial plate charge.

## Removal of Fan Shroud

1. Disconnect all power to the unit before servicing.
2. To access the condenser coil for cleaning or to service the outdoor fan, first remove the side grilles.
3. The fan shroud sides can then be removed for ease of access to the coil and the back side of the shroud by removing the seven (7) screws as shown in Figure 32.
4. The fan or coil can now be serviced.
5. Reverse the steps to reassemble.

**FIGURE 32**  
Fan Shroud Removal



Parts hidden for clarity

MIS-4045

**TABLE 10A**  
**Cooling Pressure – Full Load**

Air Temperature Entering Outdoor Coil °F

Model	Return Air Temp (DB/WB)	Pressure	75	80	85	90	95	100	105	110	115	120	125
W3SAF	75/62	Low Side	114	115	116	117	119	120	121	123	124	125	127
		High Side	277	297	318	339	362	386	411	436	463	491	519
	80/67	Low Side	122	123	124	126	127	128	130	131	132	134	135
		High Side	284	304	326	348	371	396	421	448	475	503	533
	85/72	Low Side	126	127	129	130	131	133	134	136	137	139	140
		High Side	294	315	337	360	384	410	436	463	492	521	551
W4SAF	75/62	Low Side	121	122	123	124	125	127	128	130	131	133	135
		High Side	299	320	342	365	389	415	442	471	500	531	564
	80/67	Low Side	129	130	132	133	134	135	137	139	140	142	144
		High Side	307	328	351	374	399	426	454	483	513	545	578
	85/72	Low Side	134	135	136	137	139	140	142	143	145	147	149
		High Side	318	340	363	387	413	441	470	500	531	564	598
W5SAF	75/62	Low Side	118	119	120	122	123	124	125	126	127	128	129
		High Side	300	321	343	366	389	413	438	464	491	519	547
	80/67	Low Side	126	127	129	130	131	132	133	135	136	137	138
		High Side	308	329	352	375	399	424	450	476	504	532	561
	85/72	Low Side	130	132	133	134	136	137	138	139	140	142	143
		High Side	319	341	364	388	413	439	465	493	521	551	581

Low side pressure ± 4 PSIG  
High side pressure ± 10 PSIG

Tables are based upon rated CFM (airflow) across the evaporator coil. If there is any doubt as to correct operating charge being in the system, the charge should be removed and system evacuated and recharged to serial plate charge weight.

**NOTE:** Pressure table based on high speed condenser fan operation. If condensing pressures appear elevated check condenser fan wiring. See **Condenser Fan Operation** on page 34.

**TABLE 10B**  
**Cooling Pressure – Part Load**

Air Temperature Entering Outdoor Coil °F

Model	Return Air Temp (DB/WB)	Pressure	75	80	85	90	95	100	105	110	115	120	125
W3SAF	75/62	Low Side	119	120	121	122	123	125	127	129	131	134	137
		High Side	234	258	274	292	312	334	359	387	416	448	482
	80/67	Low Side	127	128	129	131	132	134	136	138	140	143	146
		High Side	240	265	281	299	320	343	368	396	427	460	495
	85/72	Low Side	132	133	134	135	137	138	140	143	145	148	151
		High Side	249	274	291	310	331	355	381	410	442	476	512
W4SAF	75/62	Low Side	119	123	125	127	128	130	131	133	134	135	136
		High Side	218	263	286	309	332	356	380	404	429	454	480
	80/67	Low Side	127	131	133	135	137	139	140	142	143	144	145
		High Side	224	270	293	317	341	365	390	415	440	466	492
	85/72	Low Side	131	136	138	140	142	144	145	147	148	149	150
		High Side	232	279	303	328	353	378	403	429	456	482	509
W5SAF	75/62	Low Side	118	119	120	121	122	123	124	126	127	129	131
		High Side	233	270	290	311	332	355	378	403	428	454	481
	80/67	Low Side	126	127	128	129	130	132	133	135	136	138	140
		High Side	239	277	297	319	341	364	388	413	439	465	493
	85/72	Low Side	130	132	133	134	135	136	138	139	141	143	145
		High Side	248	287	308	330	353	377	402	427	454	482	510

Low side pressure ± 4 PSIG  
High side pressure ± 10 PSIG

Tables are based upon rated CFM (airflow) across the evaporator coil. If there is any doubt as to correct operating charge being in the system, the charge should be removed and system evacuated and recharged to serial plate charge weight.

**NOTE:** Pressure table based on high speed condenser fan operation. If condensing pressures appear elevated check condenser fan wiring. See **Condenser Fan Operation** on page 34.

**TABLE 11**  
**Electrical Specifications**

Model	Rated Volts & Phase	No. Field Power Circuits	Single Circuit		Multiple Circuit			
			① Minimum Circuit Ampacity	② Maximum External Fuse or Circuit Breaker	① Minimum Circuit Ampacity		② Maximum External Fuse or Circuit Breaker	
					Circuit A	Circuit B	Circuit A	Circuit B
W3SAF-A00, -A0Z -A05 -A10 -A15	230/208-1	1 1 1 1 or 2	24 31 57 83	30 35 60 90	57	26	60	30
W3SAF-B00, -B0Z -B05 -B09 -B15	230/208-3	1 1 1 1	19 20 32 51	25 25 35 60				
W3SAF-C00, -C0Z -C05 -C09 -C15	460-3	1 1 1 1	10 11 17 26	15 15 20 30				
W4SAF-A00, -A0Z -A05 -A10 -A15	230/208-1	1 1 1 1 or 2	29 32 58 84	35 35 60 90	58	26	60	30
W4SAF-B00, -B0Z -B05 -B09 -B15	230/208-3	1 1 1 1	21 21 33 51	25 25 35 60				
W4SAF-C00, -C0Z -C09 -C15	460-3	1 1 1	12 17 26	15 20 30				
W5SAF-A00, -A0Z -A05 -A10 -A15	230/208-1	1 1 1 1 or 2	39 39 59 85	50 50 60 90	59	26	60	30
W5SAF-C00, -B0Z -B09 -B15	230/208-3	1 1 1	25 34 52	30 35 60				
W5SAF-C00, -C0Z -C09 -C15	460-3	1 1 1	13 17 26	15 20 30				

① These “Minimum Circuit Ampacity” values are to be used for sizing the field power conductors. Refer to the National Electrical code (latest version), Article 310 for power conductor sizing. **CAUTION:** When more than one field power circuit is run through one conduit, the conductors must be derated. Pay special attention to note 8 of Table 310 regarding Ampacity Adjustment Factors when more than three (3) current carrying conductors are in a raceway.

② Maximum size of the time delay fuse or circuit breaker for protection of field wiring conductors.

**NOTE:** The Maximum Overcurrent Protection (MOCP) value listed is the maximum value as per UL 60335 calculations for MOCP (branch-circuit conductor sizes in this chart are based on this MOCP). The actual factory-installed overcurrent protective device (circuit breaker) in this model may be lower than the maximum UL 60335 allowable MOCP value, but still above the UL 60335 minimum calculated value or Minimum Circuit Ampacity (MCA) listed.

**IMPORTANT:** While this electrical data is presented as a guide, it is important to electrically connect properly sized fuses and conductor wires in accordance with the National Electrical Code and all local codes.

## Setting Unit Airflow

The unit is set from the factory at the default speed. Most units have three selectable cooling speed taps that can be utilized. The default speed is the lowest cooling speed. The two higher speed taps can be used for higher duct static applications so that the unit can maintain the recommended airflow as shown in Table 12. The higher speeds can also be used when higher sensible cooling is desired. To change to the higher speed taps, move the orange/black wire on the blower speed terminal block to HI. Refer to the graphs on pages 52 – 54 for the corresponding airflow of each tap. Set the unit duct static based on the highest airflow that the unit will run at.

**TABLE 12**  
Recommended Airflow

Model	Nominal Rated CFM*	Nominal Rated ESP*	Recommended Airflow Range	Factory Speed Connection
W3SAC	1150	.15	1050 - 1350	Default
W4SAC	1550	.20	1450 - 1750	Default
W5SAC	1750	.20	1650 - 2000	Default

\* Rated CFM and ESP on factory speed connection.

**NOTE:** Be sure to adjust the system static or blower speed to maintain airflows above the minimum recommendations to prevent freeze up conditions if Balanced Climate mode is activated.

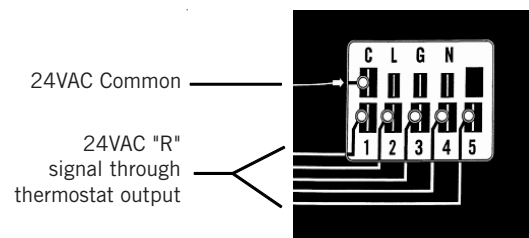
Do not operate the unit in Balanced Climate mode if running high static applications as indicated in the blower performance table. If Balanced Climate mode is activated as described on page 35, the unit

will run in this mode at all times unless there is a call for ventilation, electric heat or 2nd stage cooling from a 2-stage thermostat. At that time, the unit will automatically activate a higher speed tap.

## Blower Speeds

Five factory programmed speed taps (torque settings) are available for the motor, and are selected through different unit modes of operation. These modes are energized by 24VAC signals from the low voltage terminal block located inside the control panel by a thermostat or other controlling device. Each speed tap is programmed by Bard at the factory to different motor torque settings (see Figure 33).

**FIGURE 33**  
Speed Taps



- Speed Tap 1: Vent Speed
- Speed Tap 2: Part Load/Balanced Climate Speed
- Speed Tap 3: Default Speed
- Speed Tap 4: High Speed
- Speed Tap 5: Electric Heat Speed

Multiple motor speed taps may be energized simultaneously by 24VAC power during different modes of operation. The highest number speed tap energized takes priority with 5 being the highest and 1 being the lowest. See Table 13 for the corresponding blower speeds with the different modes of operation.

**TABLE 13**  
Blower Speeds for Unit Operational Modes

Unit Operation	Thermostat Inputs – 24VAC								Speed Taps					Blower Speed	Compressor Operation
	G	Y1	Y2	Y3	W1	W2	A	D	1	2	3-4	5 <sup>1</sup>			
Blower Only	X								X					Vent/Blower Only	Off
Part Load Cool	X	X							X	X				Balanced Climate	On
Balanced Climate Cooling <sup>2</sup>	X	X	X						X	X				Balanced Climate	On
Full Load Cool	X	X	X	X					X	X	X			Lo/Hi	On
1st Stage Heat					X								X	Lo/Hi	Off
2nd Stage Heat					X	X							X	Lo/Hi	Off
Dehumidify <sup>3</sup>								X	X	X				Balanced Climate	On

<sup>1</sup> Fan speed is selectable through the blower speed control terminal block. LO (default) or HI speeds can be used.

<sup>2</sup> Y2-Y3 low voltage strip jumper must be removed.

<sup>3</sup> Dehumidification operation is disabled when a call for heating or cooling occurs. Unit runs at Balanced Climate speed during dehumidification operation.

Programmed blower speed taps are as follows (see also Figure 34):

Speed Tap 1: **Vent/blower only** speed

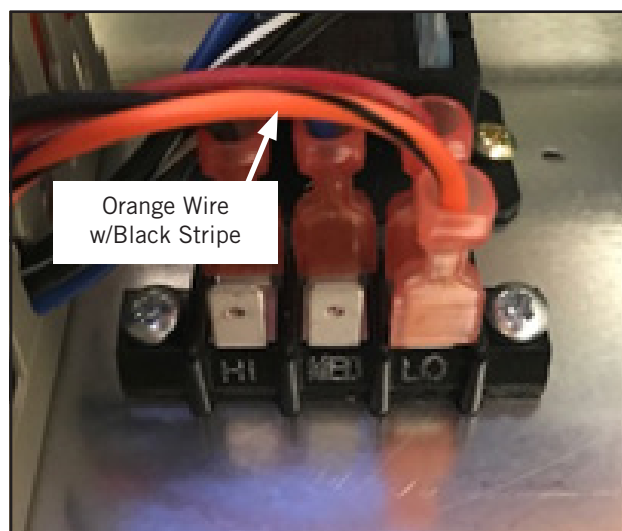
Speed Tap 2: **Part load/Balanced Climate** speed

Speed Tap 3: **Default LO cooling & heating** speed. Energized by default for cooling operation through the blower speed tap selection and is labeled as LO.

Speed Tap 4: **Optional HI cooling & heating** speed. Selected manually through the blower speed tap selection and is labeled as HI.

Speed Tap 5: **Designated electric heat** speed. Energized by B/W1.

**FIGURE 34**  
**Speed Taps**



### ***Speed Tap 1 – Vent/Blower Only***

Speed taps 1 and 2 are programmed to identical torque settings in the ECM motor. This means that if speed tap 1 is energized, the airflow amount will be the same as part load airflow. Tap 1 is used when a vent is installed and ventilation is called for by energizing the A terminal of the low voltage terminal block with 24VAC. Speed tap 1 is the lowest priority; if any of the other speed taps are energized, they will override speed tap 1.

### ***Speed Tap 2 – Part Load/Balanced Climate***

Speed tap 2 is programmed to a lower than rated speed in the ECM motor. This speed is used for part load Y1 operation and Balanced climate, if utilized. In order for Balanced Climate speed to be used during compressor cooling mode, the jumper between Y2 and Y3 must be removed. This means that if speed tap 2 is energized, the airflow amount will be lower than default airflow. Tap 2 is used when Part load is called for by energizing the Y1 terminal of the low voltage terminal block with 24VAC. Speed tap 2 is overridden if taps 3, 4, or 5 are energized.

### ***Speed Tap 3 – Default LO Cooling***

Speed tap 3 is programmed for rated speed in the SelecTech motor. This means that if speed tap 3 is energized, the airflow amount will be the default airflow. Tap 3 is used by default when cooling is called for by energizing the Y3 terminal of the low voltage terminal block with 24VAC. The unit is shipped with the jumper between Y2 and Y3 installed and it must be removed to use Balanced Climate mode. The unit is shipped with the orange/black wire connected to terminal LO (rated speed) on the blower selection speed terminal block. Speed tap 3 can be overridden if taps 4 or 5 are energized by changing the position of the orange/black wire on the blower selection speed terminal block to HI (4) position.

### ***Speed Tap 4 – Optional HI Cooling***

Speed tap 4 is programmed to a higher than rated speed in the ECM motor. This is a user-selectable airflow amount that will be higher than rated airflow. Tap 4 is used for cooling operation if the orange/black wire on the blower speed selection terminal block is moved to HI. Speed tap 4 can be overridden if tap 5 is energized.

### ***Speed Tap 5 – Electric Heat Speed***

Speed tap 5 is programmed to a designated electric heat speed that is equivalent to the units rated airflow. Tap 5 is used when electric heat is installed and with a call for heating to B terminal on the low voltage terminal block.

## **Dirty Filter Switch (Optional)**

1. Disconnect all power to the unit. Remove control panel outer cover and upper front panel.
2. The dirty filter switch is located on top of the filter partition between the blower wheels (see Figure 35 on page 50). The dirty filter indicator light and reset switch is located on the right side of the filter access opening above the control panel. Remove the cover on the dirty filter switch and ensure the knob is set at 0.4" W.C. (see Figure 35 on page 51). This is only a recommended starting point prior to making switch adjustments. Switch setting is highly dependent on filter type used, blower speed, unit ducting and other unit installation characteristics. See **Dirty Filter Switch Adjustment** instructions on how to make proper switch adjustments.
3. Re-install upper front panel.

### **Dirty Filter Switch Adjustment**

1. Apply power to the unit.
2. Turn the unit indoor blower on (energize R-G on low voltage terminal board).
3. With air filters installed and switch initially set at 0.4" W.C. (see Step 2 under **Dirty Filter**

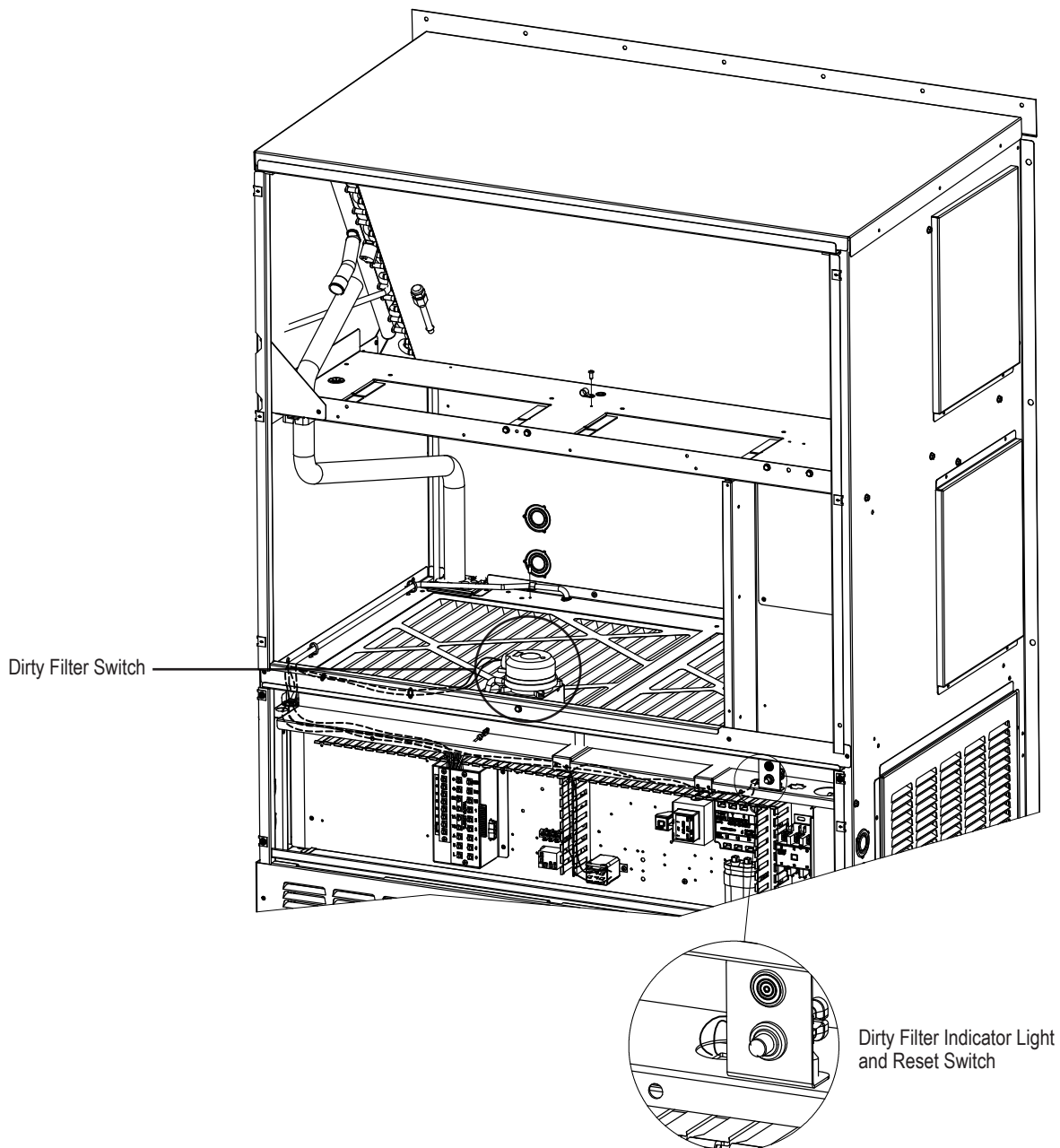
**Switch**), begin restricting the air filter of the unit using a piece of cardboard under the filters until the switch trips and the light comes on. If the filter is restricted by 75% (or desired restriction amount), skip to Step 6.

4. If switch setting adjustment is required, disconnect power to the unit. Remove the upper front panel and the cover on the airflow switch so that adjustment can be made. If the switch tripped before 75% restriction was reached, turn the knob

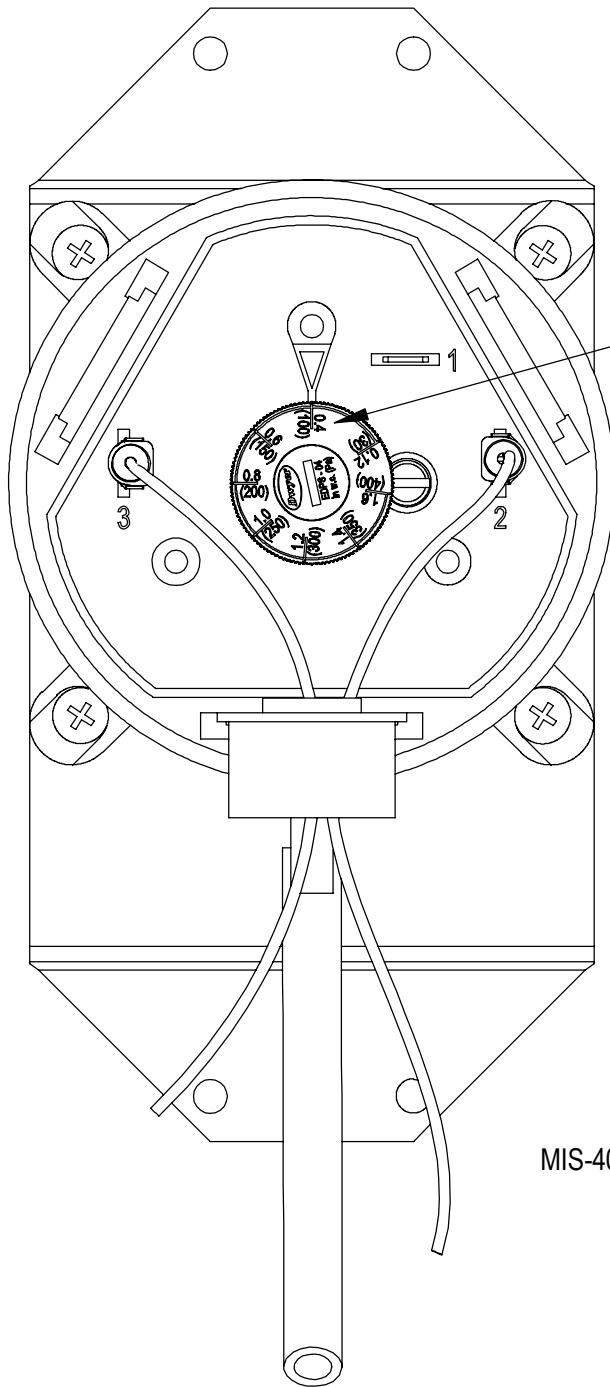
slightly clockwise. If the switch tripped after 75%, turn the knob counter-clockwise (see Figure 36).

5. Replace the upper front panel and repeat Steps 1-3. Continue to make adjustments described in Step 4 until the desired restriction is obtained.
6. Remove the restriction and reset the filter switch. Replace the switch cover once adjustment is complete.
7. Install the outer control panel cover. This completes the adjustment.

**FIGURE 35**  
**Dirty Filter Switch and Dirty Filter Indicator Light/Reset Switch**



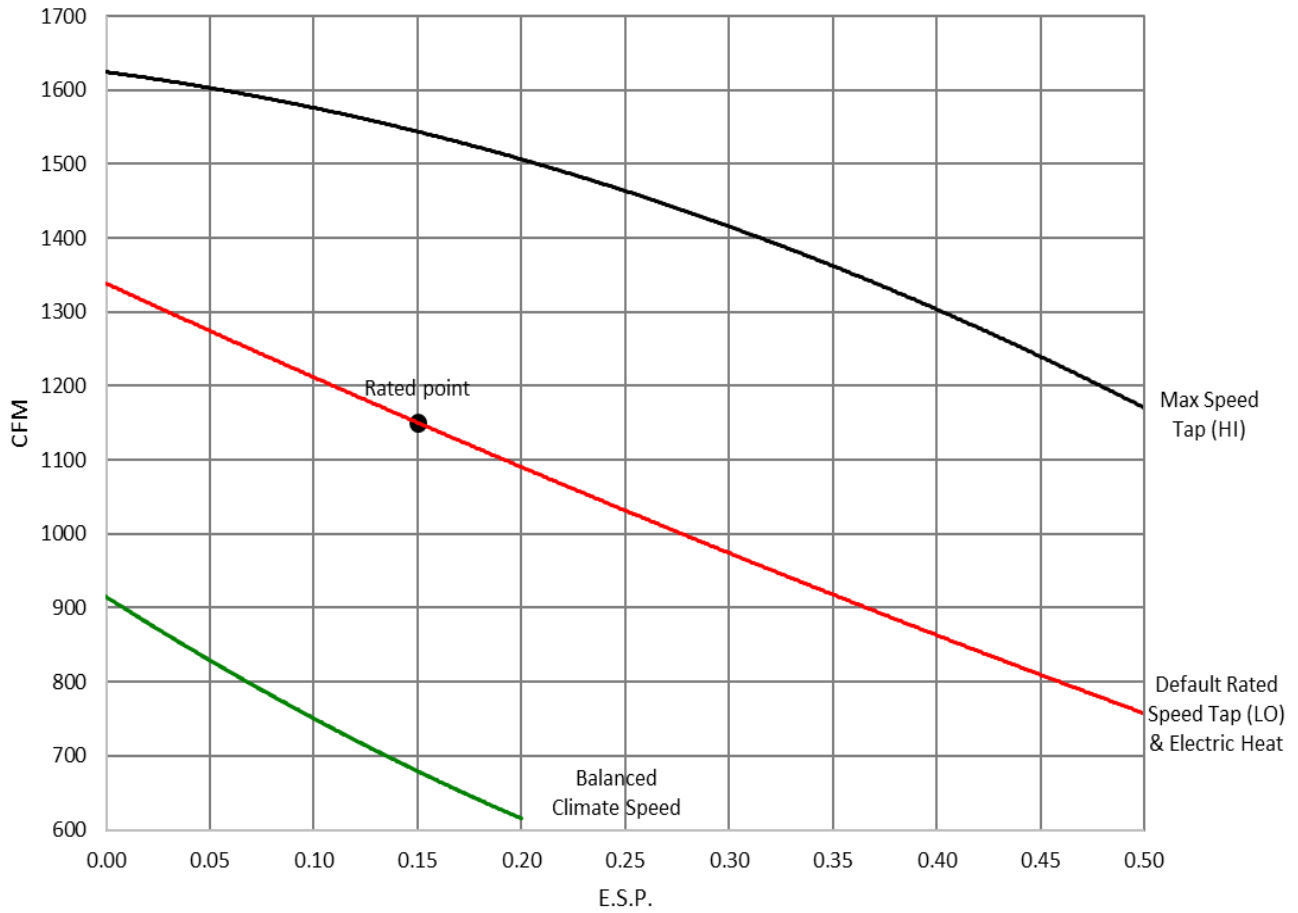
**FIGURE 36**  
**Adjusting Dirty Filter Switch**



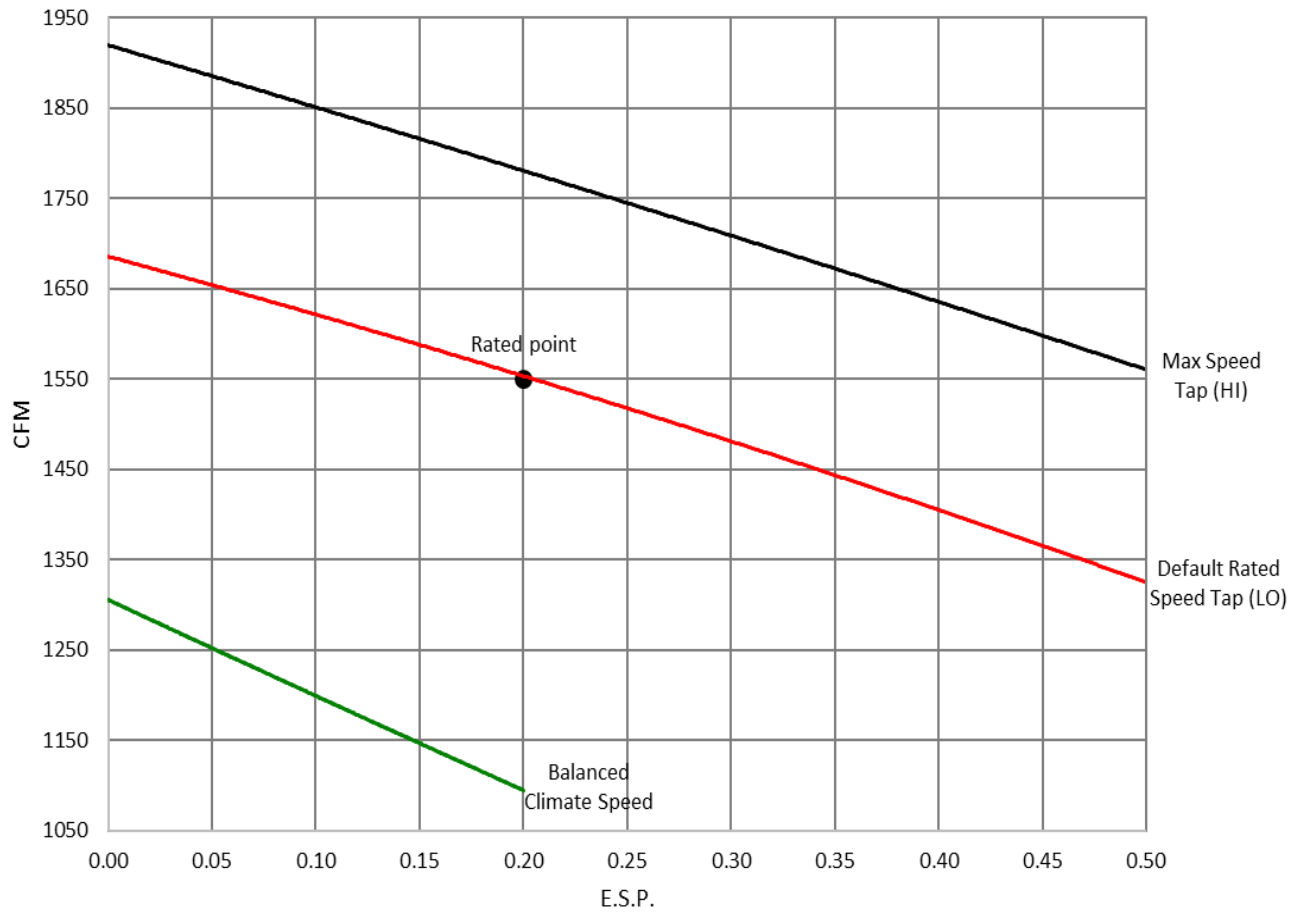
TURN CLOCKWISE TO INCREASE  
RESTRICTION AMOUNT REQUIRED  
TO ACTIVATE THE SWITCH AND  
COUNTER-CLOCKWISE TO  
DECREASE RESTRICTION AMOUNT

MIS-4086 B

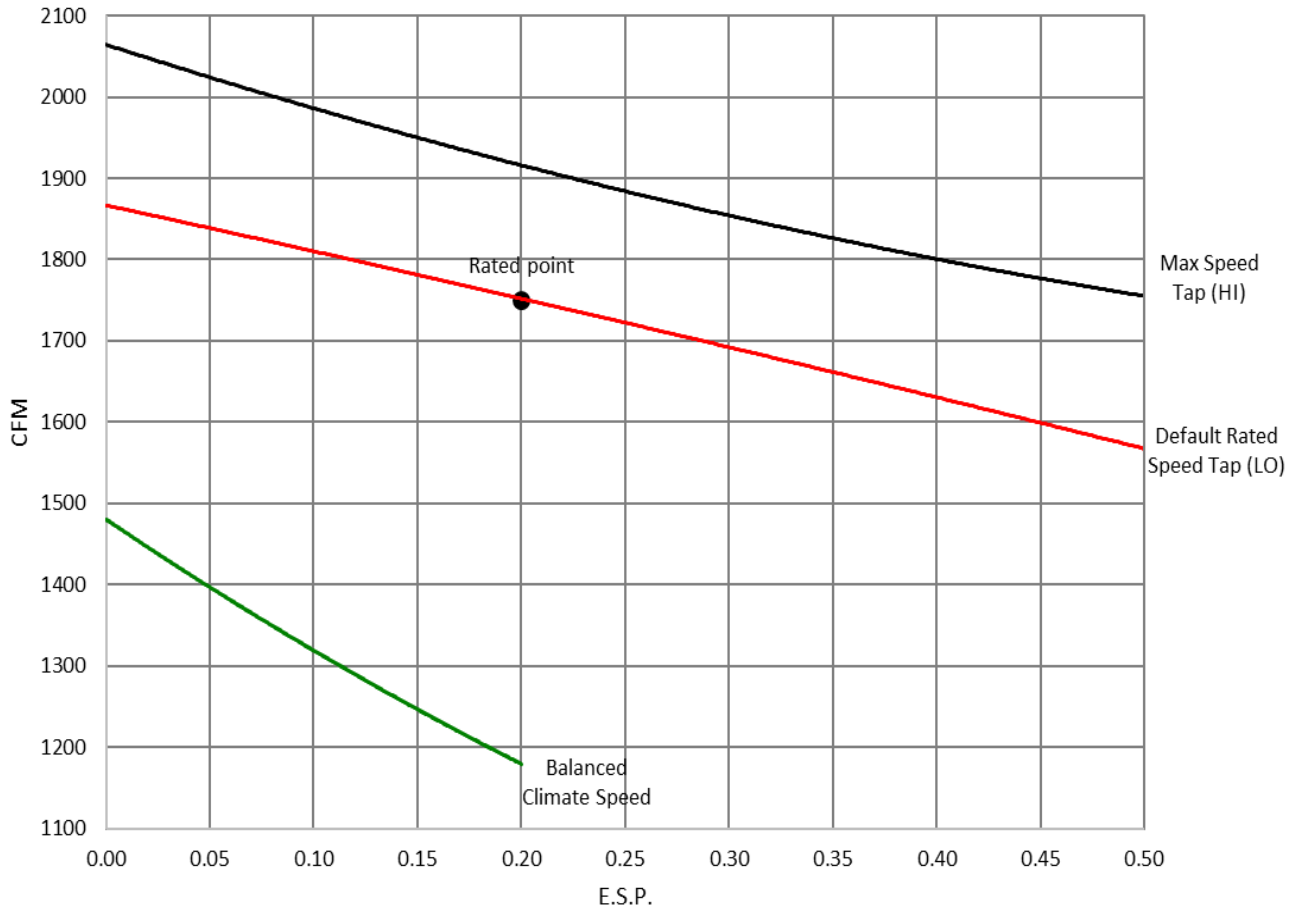
**GRAPH 1**  
**W3SAF Indoor Airflow Performance – Wet Coil**



**GRAPH 2**  
**W4SAF Indoor Airflow Performance – Wet Coil**



**GRAPH 3**  
**W5SAF Indoor Airflow Performance – Wet Coil**



**TABLE 14**  
**Maximum ESP of Operation**  
**Electric Heat Only**

Model	W3SAF/D	W4SAF/D	W5SAF/D
-A05	.50	.50	.50
-A10	.50	.50	.50
-A15	.50	.50	.50
-B05	.50	.50	.50
-B09	.50	.50	.50
-B15	.50	.50	.50
-C05	.50	.50	.50
-C09	.50	.50	.50
-C15	.50	.50	.50

Values shown are for units equipped with a 2" pleated MERV 13 filter.

**TABLE 15**  
**Electric Heat**

Electric Heat Nomenclature	Nominal kW	Total kW and BTUH @ Field-Supplied Voltage										
		@ 230V				@ 208V				@ 460V		
		kW	1 PH Amps	3 PH Amps	BTUH	kW	1 PH Amps	3 PH Amps	BTUH	kW	3 PH Amps	BTUH
05	5	4.6	20.0	11.5	15,700	3.8	18.0	10.4	12,800	4.6	5.8	15,700
09	9	8.3		20.8	28,300	6.8		18.7	23,000	8.3	10.4	28,300
10	10	9.2	40.0		31,400	7.5	36.1		25,600			
15	15	13.8	60.0	34.6	47,100	11.3	54.1	31.2	38,400	13.8	17.3	47,100

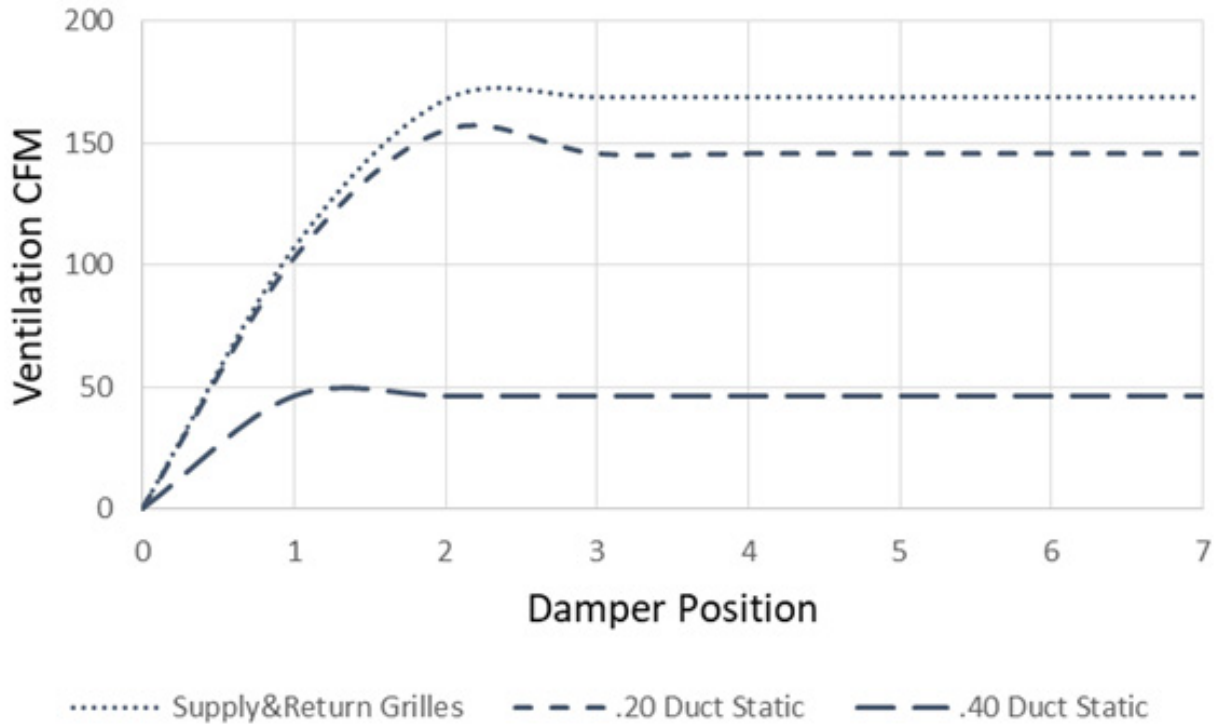
**TABLE 16**  
**Vent and Control Options**

<b>Part Number</b>	<b>Description</b>	<b>230V Units</b>	<b>460V Units</b>
CMC-32	Start Kit (230V 1-Phase)	X	
CMC-33	Dirty Filter Switch Kit	X	X
CMC-35	Alarm Relay	X	X
CMC-38	Crankcase Heater (230V 1-Phase)	X	
CMC-39	Crankcase Heater (460V 3-Phase)		X
CMC-41	Crankcase Heater (230V 3-Phase)	X	
CMA-39	LAC - On/Off	X	X
CMA-43	ODT	X	X
CMA-44	DDC	X	X
BOP5	Blank Off Plate	X	X
FAD-NE5	Fresh Air Damper - No Exhaust	X	X
FAD-BE5	Fresh Air Damper - Barometric Exhaust	X	X
CRV-F5	Commercial Ventilator - On/Off, Spring Return	X	X
CRV-V5	Commercial Ventilator - 0-10V, Spring Return	X	X
ECON-NC5	Economizer - Bldg. Equipment, 0-10V, No Controls	X	X
ECON-WD5	Economizer - Bldg. Equipment, Enthalpy	X	X
ECON-DB5	Economizer - Bldg. Equipment, Temperature	X	X
ERV-FA5	Energy Recovery Ventilator (230V)	X	
ERV-FC5	Energy Recovery Ventilator (460V)		X

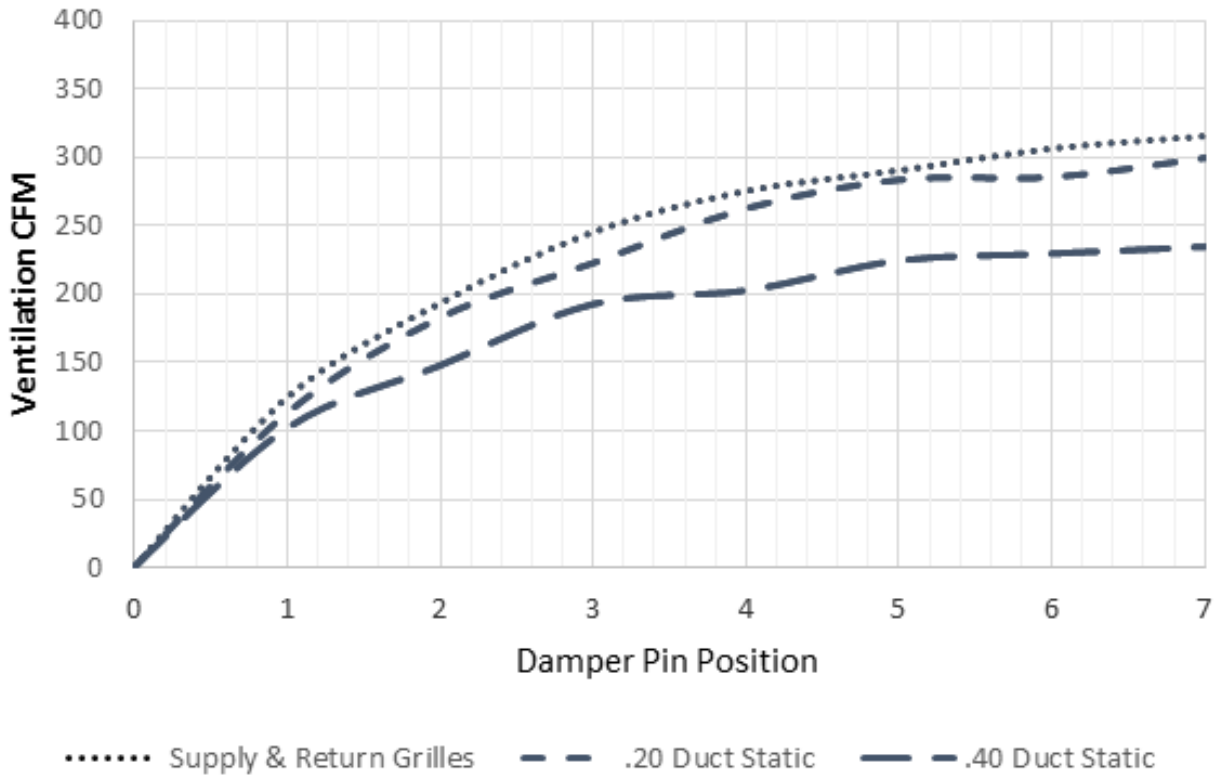
**TABLE 17**  
**Optional Accessories**

	W3SAF-A	W3SAF-B	W3SAF-C	W3SAFDA	W3SAFDB	W3SAFDC	W4SAF-A	W4SAF-B	W4SAF-C	W4SAFDA	W4SAFDB	W4SAFDC	W5SAF-A	W5SAF-B	W5SAF-C	W5SAFDA	W5SAFDB	W5SAFDC	
<b>Heater Kits</b>	EHWA03SA-A05	X			X														
	EHWA03SA-A10	X			X														
	EHWA03SA-A15	X			X														
	EHWA03SA-B05		X			X													
	EHWA03SA-B09		X			X													
	EHWA03SA-B15		X			X													
	EHWA03SA-C05			X			X												
	EHWA03SA-C09			X			X												
	EHWA03SA-C15			X			X												
	EHWA04SA-A05							X											
	EHWA042A-B09														X			X	
	EHWA042A-C09															X			X
	EHWA042A-C15															X			X
	EHWA048A-A10							X			X								
	EHWA048A-A15							X			X								
	EHWA04SA-B05								X										
	EHWA048A-B09								X			X							
	EHWA048A-B15								X										
	EHWA048A-C09									X			X						
	EHWA048A-C15									X									
	EHWA04SA-A05										X								
	EHWA04SA-B05											X							
	EHWA048ADC05												X						
	EHWA060A-A05													X			X		
	EHWA060A-A10													X			X		
	EHWA060A-A15													X			X		
EHWA060A-B15														X			X		
<b>Circuit Breaker (WMCBC)</b>	WMCBC-03B		X			X			X										
	WMCBC-04A	X			X														
	WMCBC-04B										X			X				X	
	WMCBC-05A						X			X									
	WMCBC-06C			X			X			X			X		X				X
	WMCBC-08A												X			X			

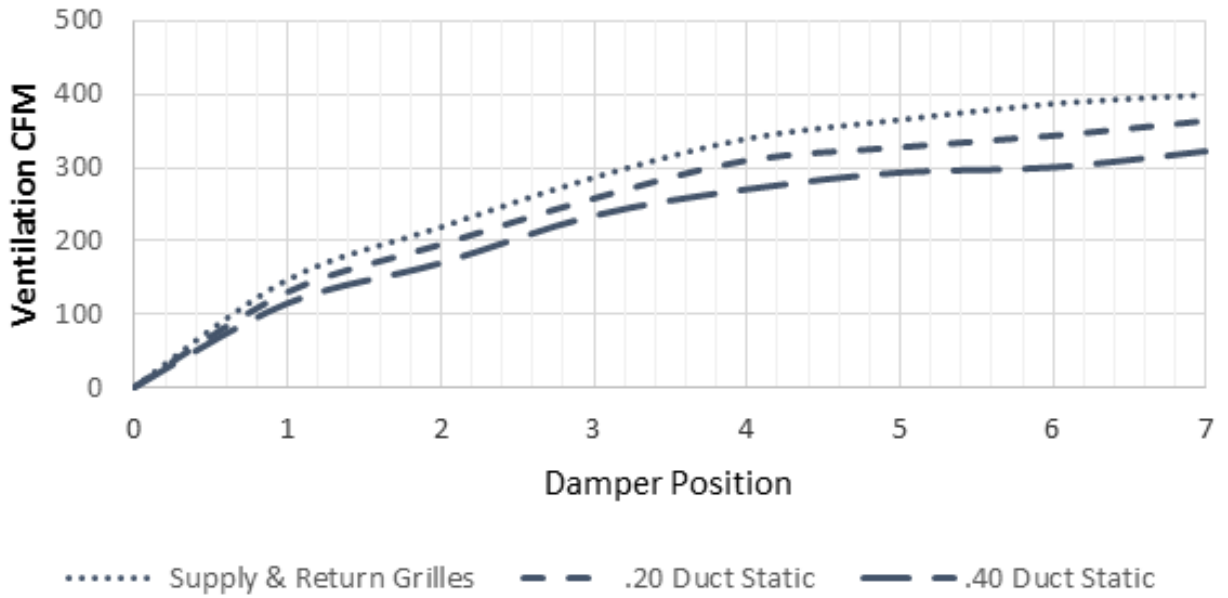
**GRAPH 4**  
**W3SAF FAD-NE5 W/O Exhaust Ventilation Delivery**



**GRAPH 5**  
**W4SAF FAD-NE5 W/O Exhaust Ventilation Delivery**



GRAPH 6  
W5SAF FAD-NE5 W/O Exhaust Ventilation Delivery





# REPLACEMENT PARTS MANUAL

## R-454B Step Capacity 2 Stage Wall Mount Air Conditioner

### Models:

W3SAF-A	W4SAF-A	W5SAF-A
W3SAF-B	W4SAF-B	W5SAF-B
W3SAF-C	W4SAF-C	W5SAF-C
W3SAFDA	W4SAFDA	W5SAFDA
W3SAFDB	W4SAFDB	W5SAFDB
W3SAFDC	W4SAFDC	W5SAFDC

### Contents

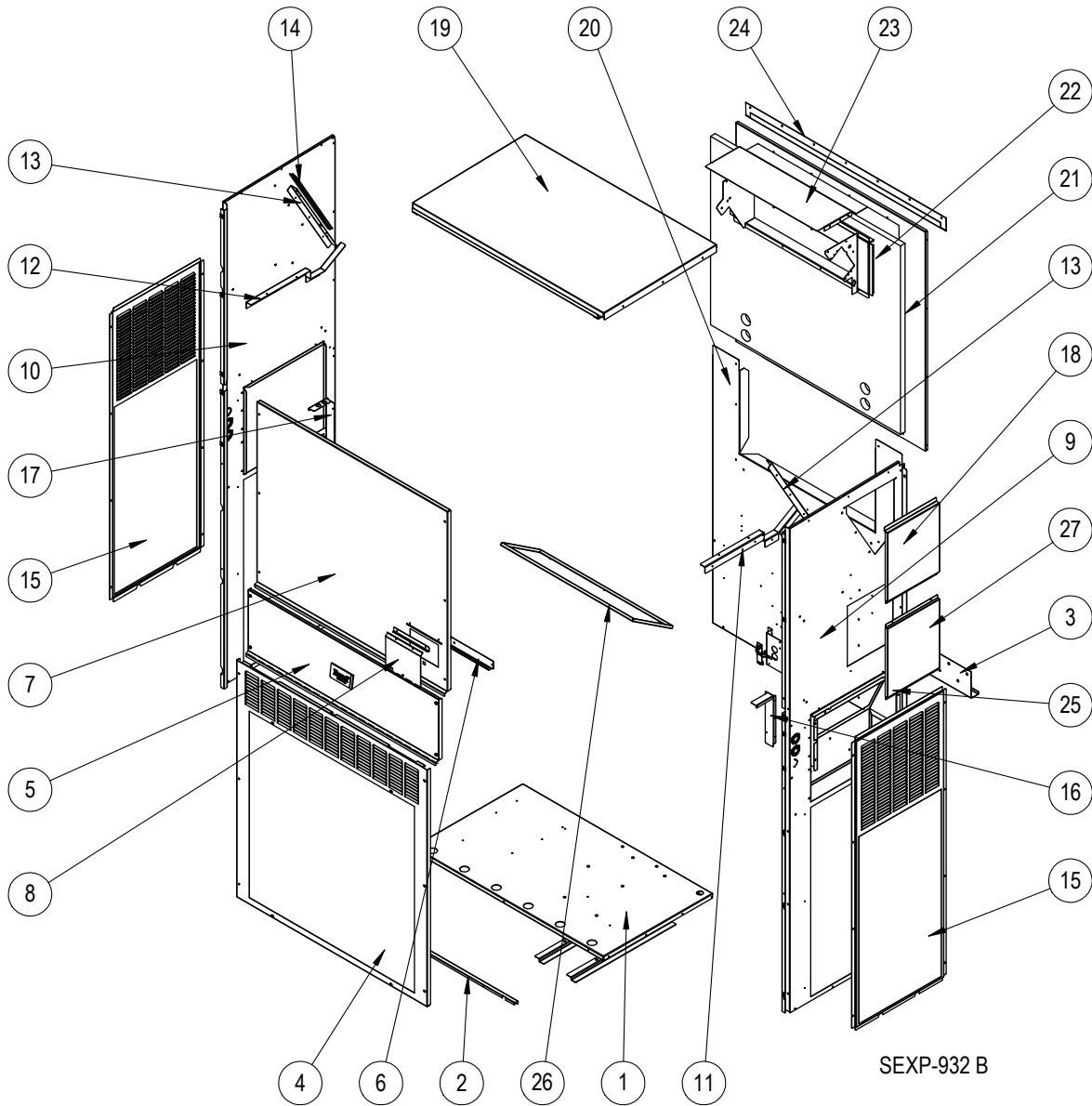
Description	Page	Description	Page
External Parts – Standard & Dehum.		Control Panel – Standard & Dehum.	
♦ Exploded View .....	2	♦ Layout View .....	14
♦ Usage List .....	3	♦ Usage List .....	15
♦ Usage List .....	4	♦ Usage List .....	16
Internal Parts – Standard & Dehum.		Blower Assembly	
♦ Exploded View .....	6	♦ Exploded View .....	17
♦ Usage List .....	7	♦ Usage List .....	17
♦ Usage List .....	8		
Functional Components – Standard & Dehum.		<b>General Notes</b>	
♦ Exploded View .....	10	➤ Revised and/or additional pages may be issued from time to time.	
♦ Usage List .....	11	➤ A complete and current manual consists of pages shown in the following contents section.	
♦ Usage List .....	12		
EEV Controller Assembly		<b>Important</b>	
♦ Exploded View .....	13	➤ Contact the installing and/or local Bard distributor for all parts requirements. Be sure to have the complete model and serial number available from the unit rating plates.	
♦ Usage List .....	13		



Bard Manufacturing Company, Inc.  
Bryan, Ohio 43506  
www.bardhvac.com

Manual: 2110-1487  
Supersedes: **NEW**  
Date: 11-20-24

# EXTERNAL PARTS – STANDARD & DEHUMIDIFICATION



This drawing to be used for reference for pages 3 and 4

## EXTERNAL PARTS – STANDARD & DEHUMIDIFICATION

Dwg No.	Part Number	Description	W3SAF-A, B, C	W3SAFDA, B, C	W4SAF-A, B, C	W4SAFDA, B, C
1	127-574BX	Unit Base	X	X	X	X
1	127-584BX ③	Unit Base	0	0	0	0
2	113-762BX	Front Base Bracket	X	X	X	X
2	113-797BX ③	Front Base Bracket	0	0	0	0
3	113-140BX	Bottom Mounting Bracket	X	X	X	X
4	119-125-*BX ①	Front Grille	X	X	X	X
4	119-148BX ②	Front Grille	0	0	0	0
4	119-135BX ③	Front Grille	0	0	0	0
5	533-301-*BX ①	Control Panel Cover (Outer)	X	X	X	X
5	533-309BX ②	Control Panel Cover (Outer)	0	0	0	0
5	533-310BX ③	Control Panel Cover (Outer)	0	0	0	0
6	165-608-*BX ①	Rain Channel	X	X	X	X
6	165-609BX ②	Rain Channel	0	0	0	0
6	165-610BX ③	Rain Channel	0	0	0	0
7	515-323-*BX ①	Upper Front	X	X	X	X
7	515-328BX ②	Upper Front	0	0	0	0
7	515-330BX ③	Upper Front	0	0	0	0
8	153-717-*BX ①	Disconnect Access Door	X	X	X	X
8	153-723BX ②	Disconnect Access Door	0	0	0	0
8	153-724BX ③	Disconnect Access Door	0	0	0	0
9	501-1127-*BX ①	Right Side	X	X	X	X
9	501-1128BX ②	Right Side	0	0	0	0
9	501-1129BX ③	Right Side	0	0	0	0
10	501-1054-*BX ①	Left Side	X	X	X	X
10	501-1073BX ②	Left Side	0	0	0	0
10	501-1077BX ③	Left Side	0	0	0	0
11	105X1454BX	Right Support Angle	X	X	X	X
12	105Y1454BX	Left Support Angle	X	X	X	X
13	105-1457BX	Coil Support	2	2	2	2
14	147-055BX	Coil Support Offset	X	X	X	X
15	119-126-*BX ①	Side Grille	2	2	2	2
15	119-142BX ②	Side Grille	2	2	2	2
15	119-136BX ③	Side Grille	2	2	2	2
16	105-1450BX	Right Control Panel Angle	X	X	X	X
17	105-1451BX	Left Control Panel Angle	X	X	X	X
18	543-221-*BX ①	Heater Access Cover	X	X	X	X
18	543-228BX ②	Heater Access Cover	0	0	0	0
18	543-229BX ③	Heater Access Cover	0	0	0	0
19	507-382-*BX ①	Top	X	X	X	X
19	507-391BX ②	Top	0	0	0	0
19	507-392BX ③	Top	0	0	0	0
20	109-412BX	Lower Back	X	X	X	X
20	109-418BX ②	Lower Back	0	0	0	0
20	109-422BX ③	Lower Back	0	0	0	0
21	509-411BX	Upper Back	X	X	X	X
21	509-417BX ②	Upper Back	0	0	0	0
21	509-421BX ③	Upper Back	0	0	0	0
22	111-299BX	Outlet Air Frame Assembly	X	X	X	X
23	535-129BX	Heat Shield	X	X	X	X
24	113-150-*BX ①	Top Rain Flashing	X	X	X	X
24	113-150-4BX ②	Top Rain Flashing	0	0	0	0
24	113-359BX ③	Top Rain Flashing	0	0	0	0
25	539-406BX	Fresh Air Damper Assembly	X	X	X	X
25	543-222BX	Intake Blank Off Plate	0	0	0	0
26	543-220BX	Exhaust Blank Off Plate	X	X	X	X
27	543-248-*BX ①	Access Cover	X	X	X	X
27	543-250BX ②	Access Cover	0	0	0	0
27	543-251BX ③	Access Cover	0	0	0	0
NS	5252-033BX	Bard Nameplate	X	X	X	X

① Exterior cabinet parts are manufactured with various paint color options. To ensure the proper paint color is received, include the complete model and serial number of the unit for which cabinet parts are being ordered.

X – Standard Component  
0 – Optional Component

② Exterior cabinet parts are manufactured from aluminum Code "A"  
#24 - Top rain flashing not available in aluminum; order 113-150-4 (Buckeye Gray).  
③ Exterior cabinet parts are manufactured from stainless steel Code "S"

# EXTERNAL PARTS – STANDARD & DEHUMIDIFICATION

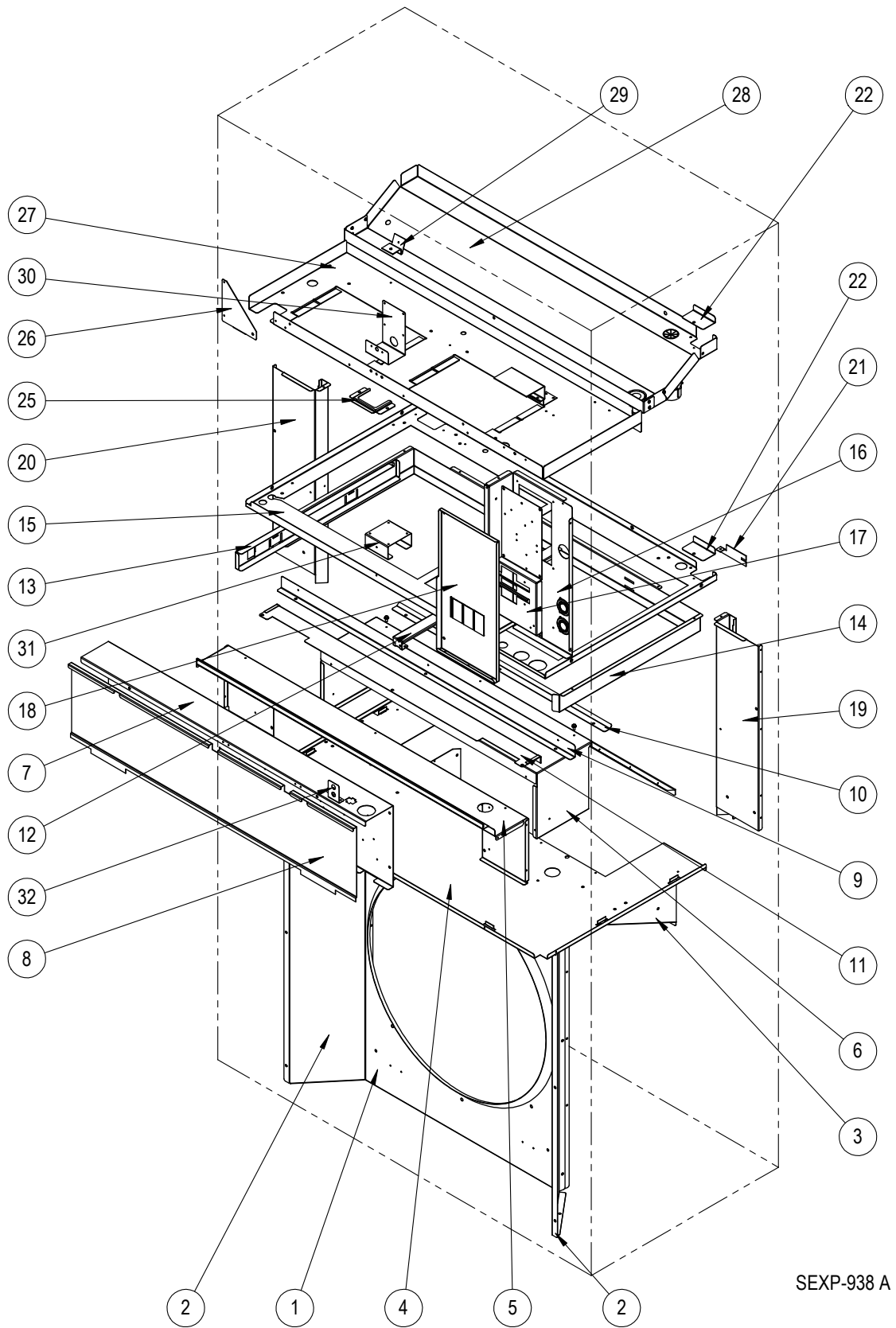
Dwg No.	Part Number	Description	W5SAF-A, B, C	W5SAFDA, B, C
1	127-574BX	Unit Base	X	X
1	127-584BX ③	Unit Base	0	0
2	113-762BX	Front Base Bracket	X	X
2	113-797BX ③	Front Base Bracket	0	0
3	113-140BX	Bottom Mounting Bracket	X	X
4	119-127-*BX ①	Front Grille	X	X
4	119-149BX ②	Front Grille	0	0
4	119-137BX ③	Front Grille	0	0
5	533-301-*BX ①	Control Panel Cover (Outer)	X	X
5	533-309BX ②	Control Panel Cover (Outer)	0	0
5	533-310BX ③	Control Panel Cover (Outer)	0	0
6	165-608-*BX ①	Rain Channel	X	X
6	165-609BX ②	Rain Channel	0	0
6	165-610BX ③	Rain Channel	0	0
7	515-324-*BX ①	Upper Front	X	X
7	515-329BX ②	Upper Front	0	0
7	515-331BX ③	Upper Front	0	0
8	153-717-*BX ①	Disconnect Access Door	X	X
8	153-723BX ②	Disconnect Access Door	0	0
8	153-724BX ③	Disconnect Access Door	0	0
9	501-1130-*BX ①	Right Side	X	X
9	501-1131BX ②	Right Side	0	0
9	501-1132BX ③	Right Side	0	0
10	501-1056-*BX ①	Left Side	X	X
10	501-1075BX ②	Left Side	0	0
10	501-1079BX ③	Left Side	0	0
11	105X1454BX	Right Support Angle	X	X
12	105Y1454BX	Left Support Angle	X	X
13	105-1455BX	Coil Support	2	2
14	147-054BX	Coil Support Offset	X	X
15	119-128-*BX ①	Side Grille	2	2
15	119-143BX ②	Side Grille	2	2
15	119-138BX ③	Side Grille	2	2
16	105-1450BX	Right Control Panel Angle	X	X
17	105-1451BX	Left Control Panel Angle	X	X
18	543-221-*BX ①	Heater Access Cover	X	X
18	543-228BX ②	Heater Access Cover	0	0
18	543-229BX ③	Heater Access Cover	0	0
19	507-382-*BX ①	Top	X	X
19	507-391BX ②	Top	0	0
19	507-392BX ③	Top	0	0
20	109-414BX	Lower Back	X	X
20	109-420BX ②	Lower Back	0	0
20	109-424BX ③	Lower Back	0	0
21	509-413BX	Upper Back	X	X
21	509-419BX ②	Upper Back	0	0
21	509-423BX ③	Upper Back	0	0
22	111-299BX	Outlet Air Frame Assembly	X	X
23	535-129BX	Heat Shield	X	X
24	113-150-*BX ①	Top Rain Flashing	X	X
24	113-150-4BX ②	Top Rain Flashing	0	0
24	113-359BX ③	Top Rain Flashing	0	0
25	539-406BX	Fresh Air Damper Assembly	X	X
25	543-222BX	Intake Blank Off Plate	0	0
26	543-220BX	Exhaust Blank Off Plate	X	X
27	543-248-*BX ①	Access Cover	X	X
27	543-250BX ②	Access Cover	0	0
27	543-251BX ③	Access Cover	0	0
NS	5252-033BX	Bard Nameplate	X	X

① Exterior cabinet parts are manufactured with various paint color options. To ensure the proper paint color is received, include the complete model and serial number of the unit for which cabinet parts are being ordered.

X – Standard Component  
0 – Optional Component

*This page intentionally left blank*

# INTERNAL PARTS - STANDARD & DEHUMIDIFICATION



SEXP-938 A

**This drawing to be used for reference for pages 7 and 8**

## INTERNAL PARTS – STANDARD & DEHUMIDIFICATION

Dwg No.	Part Number	Description	W3SAF-A, B	W3SAF-C	W3SAFDA, B	W3SAFDC	W4SAF-A, B	W4SAF-C	W4SAFDA, B	W4SAFDC
1	125-089BX	Fan Shroud	X	X	X	X	X	X	X	X
1	125-093BX ①	Fan Shroud	0	0	0	0	0	0	0	0
2	125-090BX	Fan Shroud Side Access Cover	2	2	2	2	2	2	2	2
2	125-094BX ①	Fan Shroud Side Access Cover	2	2	2	2	2	2	2	2
3	121-586BX	Condenser Partition Insert	X	X	X	X	X	X	X	X
3	121-600BX ①	Condenser Partition Insert	0	0	0	0	0	0	0	0
4	121-585BX	Condenser Partition	X	X	X	X	X	X	X	X
4	121-599BX ①	Condenser Partition	0	0	0	0	0	0	0	0
5	521-630BX	Front Exhaust Partition	X	X	X	X	X	X	X	X
6	521-587BX	Exhaust Partition	X	X	X	X	X	X	X	X
7	Control Panel Assy.	See Control Panel Assy. Drawing & Parts List	X	X	X	X	X	X	X	X
8	133-330BX	Control Panel Cover (Inner)	X	X	X	X	X	X	X	X
9	105-1453BX	Front Vent Guide Rail	X	X	X	X	X	X	X	X
10	105-1452BX	Vent Guide Rail	X	X	X	X	X	X	X	X
11	135-409BX	Field Wire Shield	X	X	X	X	X	X	X	X
12	131-168BX	Filter Support Bracket	2	2	2	2	2	2	2	2
13	131-170BX	Filter Slide	X	X	X	X	X	X	X	X
14	131-169BX	Filter Rack Frame	X	X	X	X	X	X	X	X
15	121-583BX	Filter Partition	X	X	X	X	X	X	X	X
16	117-412BX	Upper Control Panel	X	X	X	X	X	X	X	X
17	127-575BX	Circuit Breaker Base	X		X		X		X	
17	127-585BX	Circuit Breaker Base - 460V		X		X		X		X
18	133-303BX	Upper Control Panel Cover	X		X		X		X	
18	133-304BX	Upper Control Panel Cover - 460V		X		X		X		X
19	135X393BX	Right Copper Chase	X	X	X	X	X	X	X	X
19	135X397BX ①	Right Copper Chase	0	0	0	0	0	0	0	0
20	135Y393BX	Left Copper Chase	X	X	X	X	X	X	X	X
20	135Y397BX ①	Left Copper Chase	0	0	0	0	0	0	0	0
21	113-796BX	Copper Retainer	2	2	2	2	2	2	2	2
22	137-920BX	Copper Fill Plate	2	2	2	2	2	2	2	2
25	113-765BX	Grommet Retainer	X	X	X	X	X	X	X	X
26	141-492BX	Blower Partition Support	X	X	X	X	X	X	X	X
27	121-582BX	Blower Partition	X	X	X	X	X	X	X	X
28	523-161BX	Drain Pan	X	X	X	X	X	X	X	X
28	523-162BX ①②	Drain Pan	0	0	0	0	0	0	0	0
29	113-816BX	TXV mounting Bracket	X	X			X	X		
29	113-768BX	EEV mounting Bracket			X	X			X	X
30	113-787BX	Airflow Switch Bracket	0	0	0	0	0	0	0	0
31	113-788BX	Filter Switch Bracket	0	0	0	0	0	0	0	0
32	113-789BX	Filter Switch Light Bracket	0	0	0	0	0	0	0	0

① Exterior cabinet parts are manufactured from stainless steel Code "S"

② For aluminum units, order 523-162 stainless steel drain pan.

X – Standard Component

0 – Optional Component

# INTERNAL PARTS – STANDARD & DEHUMIDIFICATION

Dwg No.	Part Number	Description	W5SAF-A, B	W5SAF-C	W5SAFDA, B	W5SAFDC
1	125-091BX	Fan Shroud	X	X	X	X
1	125-095BX ①	Fan Shroud	0	0	0	0
2	125-092BX	Fan Shroud Side Access Cover	2	2	2	2
2	125-096BX ①	Fan Shroud Side Access Cover	2	2	2	2
3	121-586BX	Condenser Partition Insert	X	X	X	X
3	121-600BX ①	Condenser Partition Insert	0	0	0	0
4	121-585BX	Condenser Partition	X	X	X	X
4	121-599BX ①	Condenser Partition	0	0	0	0
5	521-630BX	Front Exhaust Partition	X	X	X	X
6	521-587BX	Exhaust Partition	X	X	X	X
7	Control Panel Assy.	See Control Panel Assy. Drawing & Parts List	X	X	X	X
8	133-330BX	Control Panel Cover (Inner)	X	X	X	X
9	105-1453BX	Front Vent Guide Rail	X	X	X	X
10	105-1452BX	Vent Guide Rail	X	X	X	X
11	135-409BX	Field Wire Shield	X	X	X	X
12	131-168BX	Filter Support Bracket	2	2	2	2
13	131-170BX	Filter Slide	X	X	X	X
14	131-169BX	Filter Rack Frame	X	X	X	X
15	121-583BX	Filter Partition	X	X	X	X
16	117-412BX	Upper Control Panel	X	X	X	X
17	127-575BX	Circuit Breaker Base	X		X	
17	127-585BX	Circuit Breaker Base - 460V		X		X
18	133-303BX	Upper Control Panel Cover	X		X	
18	133-304BX	Upper Control Panel Cover - 460V		X		X
19	135X393BX	Right Copper Chase	X	X	X	X
19	135X397BX ①	Right Copper Chase	0	0	0	0
20	135Y393BX	Left Copper Chase	X	X	X	X
20	135Y397BX ①	Left Copper Chase	0	0	0	0
21	113-796BX	Copper Retainer	2	2	2	2
22	137-920BX	Copper Fill Plate	2	2	2	2
25	113-765BX	Grommet Retainer	X	X	X	X
26	141-492BX	Blower Partition Support	X	X	X	X
27	121-582BX	Blower Partition	X	X	X	X
28	523-161BX	Drain Pan	X	X	X	X
28	523-162BX ①②	Drain Pan	0	0	0	0
29	113-768BX	EEV mounting Bracket			X	X
29	113-816BX	TXV mounting Bracket	X	X		
30	113-787BX	Airflow Switch Bracket	0	0	0	0
31	113-788BX	Filter Switch Bracket	0	0	0	0
32	113-789BX	Filter Switch Light Bracket	0	0	0	0

① Exterior cabinet parts are manufactured from stainless steel Code "S"

② For aluminum units, order 523-162 stainless steel drain pan.

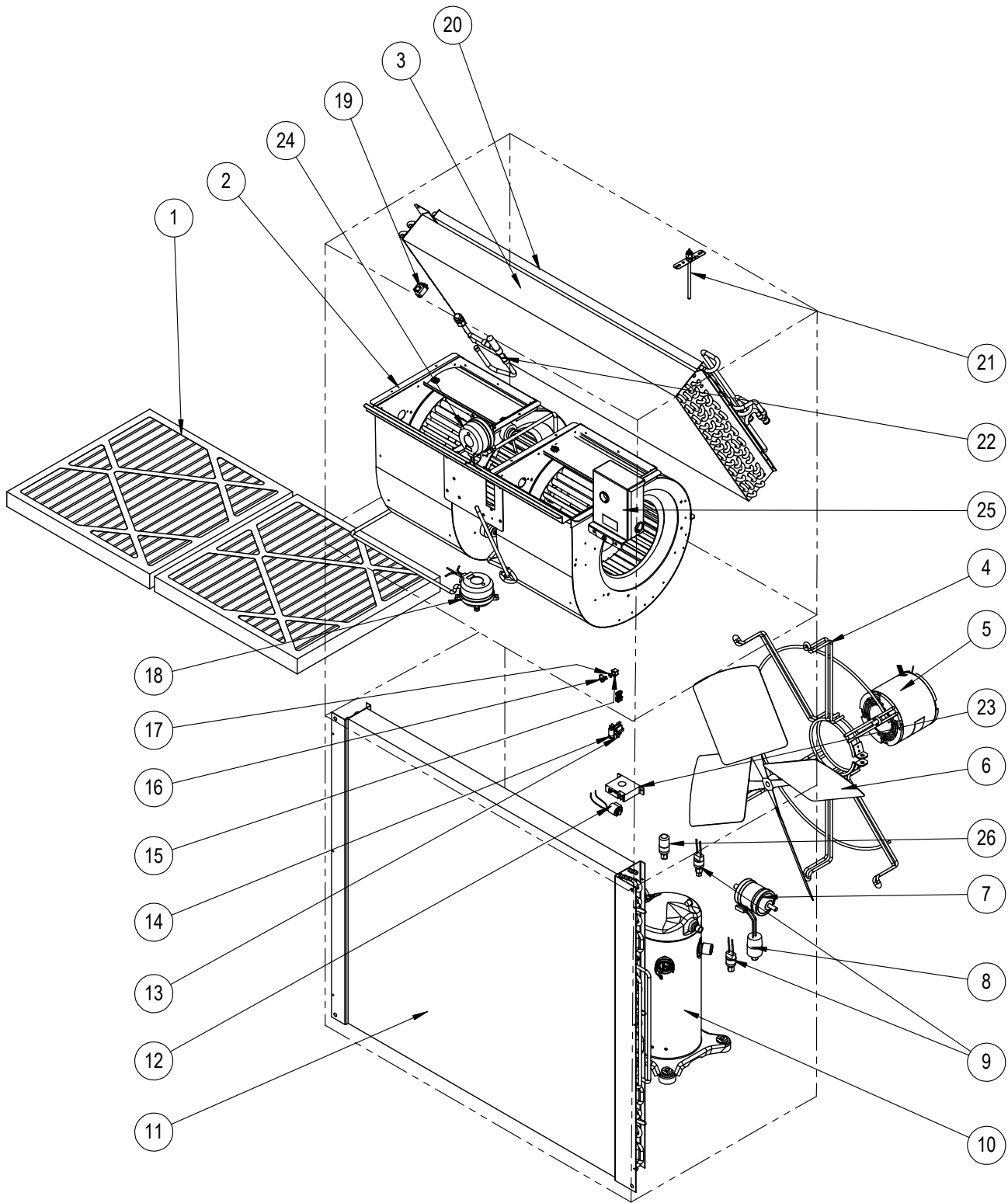
X – Standard Component

0 – Optional Component

Refer to drawing on page 6

*This page intentionally left blank*

# FUNCTIONAL COMPONENTS – STANDARD & DEHUMIDIFICATION



SEXP-931

This drawing to be used for reference for pages 11 and 12

# FUNCTIONAL COMPONENTS – STANDARD & DEHUMIDIFICATION

Dwg No.	Part Number	Description	W3SAF-A	W3SAF-B	W3SAF-C	W3SAFDA	W3SAFDB	W3SAFDC	W4SAF-A	W4SAF-B	W4SAF-C	W4SAFDA	W4SAFDB	W4SAFDC
1	7004-012	Air Filter 1" Throw-Away (20 x 20 x 1)	2	2	2	2	2	2	2	2	2	2	2	2
1	7003-085 ①	Air Filter 1" Washable (20 x 20 x 1)	2	2	2	2	2	2	2	2	2	2	2	2
1	7004-052 ①	Air Filter 2" Merv 8 (20 x 20 x 2)	2	2	2	2	2	2	2	2	2	2	2	2
1	7004-060 ①	Air Filter 2" Merv 11 (20 x 20 x 2)	2	2	2	2	2	2	2	2	2	2	2	2
1	7004-063 ①	Air Filter 2" Merv 13 (20 x 20 x 2)	2	2	2	2	2	2	2	2	2	2	2	2
2	900-387-0290BX	Blower Assembly	X	X		X	X							
2	900-387-0289BX	Blower Assembly - 460V			X			X						
2	900-387-0288BX	Blower Assembly							X	X		X	X	
2	900-387-0287BX	Blower Assembly - 460V									X			X
3	917-0368BX	Evaporator Coil w/Distributor Assy.	X	X	X	X	X	X						
3	917-0369BX	Evaporator Coil - Coated w/Distributor Assy.	0	0	0	0	0	0						
3	917-0606BX	Evaporator Coil w/Distributor Assy.							X	X	X	X	X	X
3	917-0608BX	Evaporator Coil - Coated w/Distributor Assy.							0	0	0	0	0	0
4	8200-004BX	Fan Motor Mount	X	X	X	X	X	X	X	X	X	X	X	X
4	8200-051BX ②	Fan Motor Mount - Stainless Steel	0	0	0	0	0	0	0	0	0	0	0	0
5	8105-068BX	Condenser Motor	X	X		X	X		X	X		X	X	
5	8105-071BX	Condenser Motor - 460V			X			X			X			X
6	5151-060BX	Fan Blade	X	X	X	X	X	X	X	X	X	X	X	X
6	5151C060BX ②	Fan Blade - Coated	0	0	0	0	0	0	0	0	0	0	0	0
7	5201-022BX	Filter Drier	X	X	X	X	X	X	X	X	X	X	X	X
8	CMA-39	Low Ambient Control (LAC)	0	0	0	0	0	0	0	0	0	0	0	0
9	8406-166BX	High Pressure Switch	X	X	X	X	X	X	X	X	X	X	X	X
9	8406-167BX	Low Pressure Switch	X	X	X	X	X	X	X	X	X	X	X	X
10	8000-518BX	Compressor	X			X								
10	8000-519BX	Compressor		X			X							
10	8000-520BX	Compressor			X			X						
10	8000-524BX	Compressor							X			X		
10	8000-525BX	Compressor								X			X	
10	8000-526BX	Compressor									X			X
11	5051-222BX	Condenser Coil	X	X	X	X	X	X	X	X	X	X	X	X
11	5054-222BX	Condenser Coil - Coated	0	0	0	0	0	0	0	0	0	0	0	0
12	8408-055BX	Outdoor Temperature Sensor	0	0	0	0	0	0	0	0	0	0	0	0
13	3000-1638BX	Dirty Filter Reset Switch	0	0	0	0	0	0	0	0	0	0	0	0
14	8611-094BX	Red Indicator Light - 24VAC	0	0	0	0	0	0	0	0	0	0	0	0
15	1171-023	1/4 Turn Receptacle	X	X	X	X	X	X	X	X	X	X	X	X
16	1171-022	1/4 Turn Fastener	X	X	X	X	X	X	X	X	X	X	X	X
17	1171-024	1/4 Turn Retainer	X	X	X	X	X	X	X	X	X	X	X	X
18	8301-057BX	Filter Pressure Switch	0	0	0	0	0	0	0	0	0	0	0	0
19	CMC-29	Freeze Protection Thermostat	0	0	0	0	0	0	0	0	0	0	0	0
20	5051-221BX	Reheat Coil				X	X	X				X	X	X
20	5054-221BX	Reheat Coil - Coated				0	0	0				0	0	0
21	910-1224BX	Supply Air Temperature Sensor	0	0	0	0	0	0	0	0	0	0	0	0
22	905-0819BX	Expansion Valve Assembly	X	X	X									
22	905-0820BX	Expansion Valve Assembly							X	X	X			
22	5651-245BX	Electronic Expansion Valve (Valve Only)				X	X	X				X	X	X
22	905-0737BX	Electronic Expansion Valve (EEV) Assembly				X	X	X				X	X	X
23	8301-013BX	Current Sensor	0	0	0	0	0	0	0	0	0	0	0	0
24	8301-057BX	Airflow Pressure Switch	0	0	0	0	0	0	0	0	0	0	0	0
25	910-2050-005BX	EEV Controller (see page 13 for breakdown)				X	X	X				X	X	X
26	8406-158BX	Low Pressure Transducer				X	X	X				X	X	X
26	3000-1603BX	Transducer Wire Assembly - Transducer to QC				X	X	X				X	X	X
NS	CMA-39	LAC Kit = Item #'s 8,12,19	0	0	0	0	0	0	0	0	0	0	0	0
NS	CMC-33	Dirty Filter Switch Kit = Item #'s 13,14,18	0	0	0	0	0	0	0	0	0	0	0	0
NS	CMA-44	DDC Kit = Item #'s 8,12,13,14,18,19,21,23,24	0	0	0	0	0	0	0	0	0	0	0	0
NS	5650-051BX	Dehumidification Valve				X	X	X				X	X	X
NS	5650-042BX	Rev. Valve Solenoid, Red Casing (Ranco)				X	X	X				X	X	X
NS	5650-046BX	Rev. Valve Solenoid, Black Casing (San Hua)				X	X	X				X	X	X
NS	5651-219	Check Valve				2	2	2				2	2	2
NS	5451-024	Tubing Isolation Grommet	2	2	2	4	4	4	2	2	2	4	4	4
NS	6031-009	Coremax Valve Core	2	2	2	2	2	2	2	2	2	2	2	2
NS	1171-028	Control Panel Door Clip	4	4	4	4	4	4	4	4	4	4	4	4
NS	1171-057	Control Panel Door Screw	4	4	4	4	4	4	4	4	4	4	4	4
NS	1171-027	Control Panel Door Screw Retainer	4	4	4	4	4	4	4	4	4	4	4	4
NS	5650-054	Molded Plug for Dehum Valve				X	X	X				X	X	X
NS	8301-110BX	RDS Sensor	X	X	X	X	X	X	X	X	X	X	X	X
NS	8401-036BX	RDS Relay	X	X	X	X	X	X	X	X	X	X	X	X
NS	8620-343	UV-C Field Install Kit	0	0	0	0	0	0	0	0	0	0	0	0
NS	8620-370	AIR4 NBPI Field Install Kit	0	0	0	0	0	0	0	0	0	0	0	0

NS – Not Shown

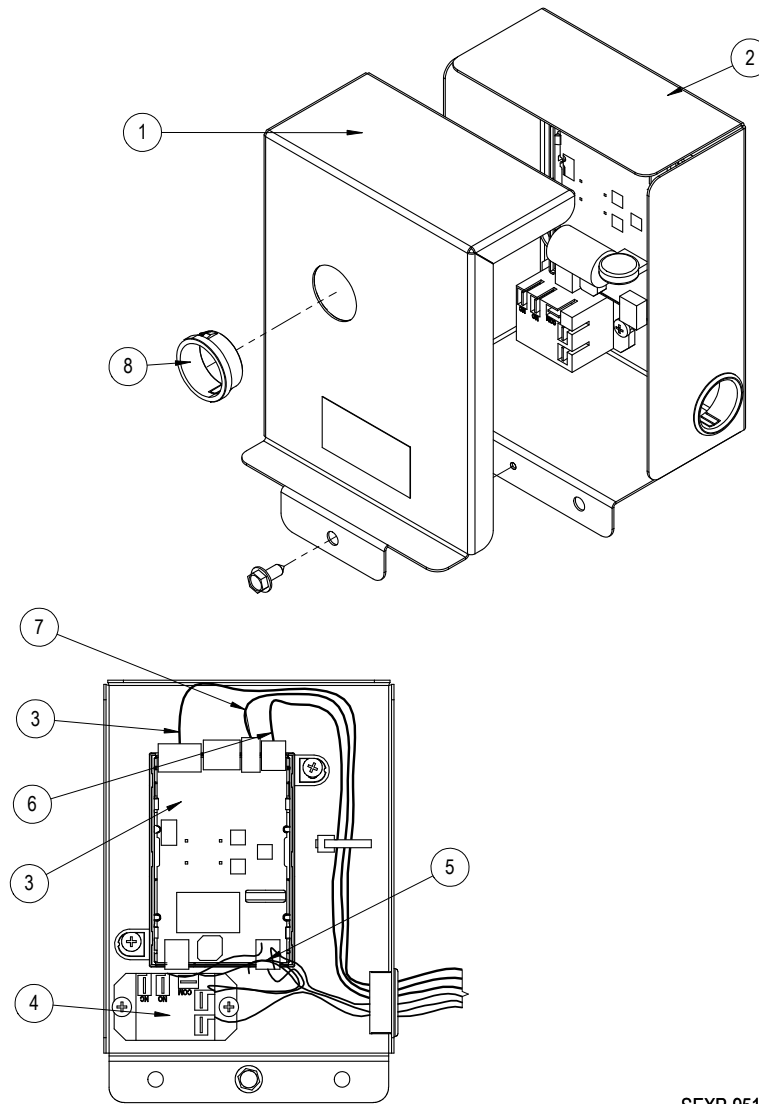
① – Optional on these models  
 ② – Used with stainless steel cabinet option

X – Standard Component  
 0 – Optional Component

# FUNCTIONAL COMPONENTS – STANDARD & DEHUMIDIFICATION

Dwg No.	Part Number	Description	W5SAF-A	W5SAF-B	W5SAF-C	W5SAFDA	W5SAFDB	W5SAFDC
1	7004-012	Air Filter 1" Throw-Away (20 x 20 x 1)	2	2	2	2	2	2
1	7003-085 ①	Air Filter 1" Washable (20 x 20 x 1)	2	2	2	2	2	2
1	7004-052 ①	Air Filter 2" Merv 8 (20 x 20 x 2)	2	2	2	2	2	2
1	7004-060 ①	Air Filter 2" Merv 11 (20 x 20 x 2)	2	2	2	2	2	2
1	7004-063 ①	Air Filter 2" Merv 13 (20 x 20 x 2)	2	2	2	2	2	2
2	900-369-0286BX	Blower Assembly	X	X		X	X	
2	900-369-0285BX	Blower Assembly - 460V			X			X
3	917-0376BX	Evaporator Coil	X	X	X	X	X	X
3	917-0377BX	Evaporator Coil	0	0	0	0	0	0
4	8200-004BX	Fan Motor Mount	X	X	X	X	X	X
4	8200-051BX ②	Fan Motor Mount - Stainless Steel	0	0	0	0	0	0
5	8105-068BX	Condenser Motor	X	X		X	X	
5	8105-071BX	Condenser Motor - 460V			X			X
6	5151-060BX	Fan Blade	X	X	X	X	X	X
6	5151C060BX ②	Fan Blade - Coated	0	0	0	0	0	0
7	5201-022BX	Filter Drier	X	X	X	X	X	X
8	CMA-39	Low Ambient Control (LAC)	0	0	0	0	0	0
9	8406-166BX	High Pressure Switch	X	X	X	X	X	X
9	8406-167BX	Low Pressure Switch	X	X	X	X	X	X
10	8000-527BX	Compressor	X			X		
10	8000-528BX	Compressor		X			X	
10	8000-529BX	Compressor			X			X
11	5051-223BX	Condenser Coil	X	X	X	X	X	X
11	5054-223BX	Condenser Coil - Coated	0	0	0	0	0	0
12	8408-055BX	Outdoor Temperature Sensor	0	0	0	0	0	0
13	3000-1638BX	Dirty Filter Reset Switch	0	0	0	0	0	0
14	8611-094BX	Red Indicator Light - 24VAC	0	0	0	0	0	0
15	1171-023	1/4 Turn Receptacle	X	X	X	X	X	X
16	1171-022	1/4 Turn Fastener	X	X	X	X	X	X
17	1171-024	1/4 Turn Retainer	X	X	X	X	X	X
18	8301-057BX	Filter Pressure Switch	0	0	0	0	0	0
19	CMC-29	Freeze Protection Thermostat	0	0	0	0	0	0
20	5051-221BX	Reheat Coil				X	X	X
20	5054-221BX	Reheat Coil - Coated				0	0	0
21	910-1224BX	Supply Air Temperature Sensor	0	0	0	0	0	0
22	905-0821BX	Expansion Valve Assembly	X	X	X			
22	905-0745BX	Electronic Expansion Valve (EEV) Assembly				X	X	X
23	8301-013BX	Current Sensor	0	0	0	0	0	0
24	8301-057BX	Airflow Pressure Switch	0	0	0	0	0	0
25	910-2050-005BX	EEV Controller (see page 13 for breakdown)				X	X	X
26	8406-158BX	Low Pressure Transducer				X	X	X
26	3000-1603BX	Transducer Wire Assembly - Transducer to QC				X	X	X
NS	CMA-39	LAC Kit = Item #'s 8,12,19	0	0	0	0	0	0
NS	CMC-33	Dirty Filter Switch Kit = Item #'s 13,14,18	0	0	0	0	0	0
NS	CMA-44	DDC Kit = Item #'s 8,12,13,14,18,19,21,23,24	0	0	0	0	0	0
NS	5451-024	Tubing Isolation Grommet	2	2	2	4	4	4
NS	6031-009	Coremax Valve Core	2	2	2	2	2	2
NS	1171-028	Control Panel Door Clip	4	4	4	4	4	4
NS	1171-057	Control Panel Door Screw	4	4	4	4	4	4
NS	1171-027	Control Panel Door Screw Retainer	4	4	4	4	4	4
NS	5650-051BX	Dehumidification Valve				X	X	X
NS	5650-042BX	Rev. Valve Solenoid, Red Casing (Ranco)				X	X	X
NS	5650-046BX	Rev. Valve Solenoid, Black Casing (San Hua)				X	X	X
NS	5651-219	Check Valve				2	2	2
NS	8301-110BX	RDS Sensor	X	X	X	X	X	X
NS	8401-036BX	RDS Relay	X	X	X	X	X	X
NS	8620-343	UV-C Field Install Kit	0	0	0	0	0	0
NS	8620-370	AIR4 NBPI Field Install Kit	0	0	0	0	0	0

# EEV CONTROLLER ASSEMBLY

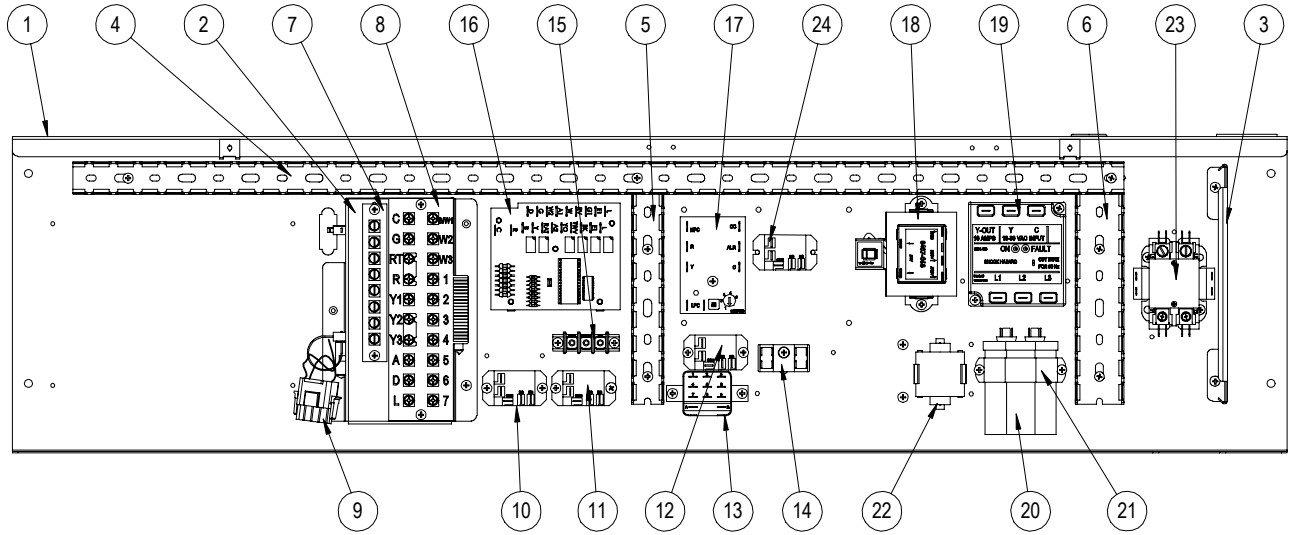


SEXP-951

910-2050-005

Dwg No.	Part Number	Description	
1	143-219BX	EEV Control Box Cover	X
2	127-572BX	EEV Control Box	X
3	8301-079-0005BX	EEV Control Module & Stator Cable	X
3	5651-246BX	EEV Stator Cable Only	X
4	8201-130BX	Control Relay	X
5	3000-1602BX	Main Wire Assembly	X
6	3000-1611BX	Transducer Wire Assembly – EEV Board to QC	X
7	8408-056BX	EEV Thermistor	X
8	8611-075	Clear Snap Plug	X

# CONTROL PANEL – STANDARD & DEHUMIDIFICATION



SEXP-1020

This drawing to be used for reference for pages 15 and 16

## CONTROL PANEL – STANDARD & DEHUMIDIFICATION

Dwg No.	Part Number	Description	W3SAF-A	W3SAF-B	W3SAF-C	W3SAFDA	W3SAFDB	W3SAFDC	W4SAF-A	W4SAF-B	W4SAF-C	W4SAFDA	W4SAFDB	W4SAFDC
1	117-411BX	Control Panel	X	X	X	X	X	X	X	X	X	X	X	X
2	910-2108BX	Complete Low Voltage Box Assembly (Sheet metal, Terminal Strip, & Wire Harness)	X	X	X	X	X	X	X	X	X	X	X	X
3	135-394BX	Wire Shield	X	X	X	X	X	X	X	X	X	X	X	X
4	8611-140-3208BX	Cable Duct - 32.5"	X	X	X	X	X	X	X	X	X	X	X	X
6	8611-244-0608BX	Cable Duct - 6.5" x 1.5" wide	2	2	2	2	2	2	2	2	2	2	2	2
7	8607-021BX	Low Voltage Terminal Strip - 8 term.	0	0	0	0	0	0	0	0	0	0	0	0
8	8607-071BX	Low Voltage Terminal Strip - 20 term.	X	X	X	X	X	X	X	X	X	X	X	X
9	3000-1524BX	Vent Jumper Plug (used when no vent option)	X	X	X	X	X	X	X	X	X	X	X	X
10	8201-130BX	Alarm Relay (Kit = CMC-35)	0	0	0	0	0	0	0	0	0	0	0	0
11	8201-130BX	Blower Speed Relay	X	X	X	X	X	X	X	X	X	X	X	X
12	8201-130BX	Dehumidification Control Relay				X	X	X				X	X	X
13	8201-159BX	Dirty Filter Relay (Kit = CMC-33)	0	0	0	0	0	0	0	0	0	0	0	0
14	8607-017BX	Terminal Block (LAC Kit = CMA-39)	0	0	0	0	0	0	0	0	0	0	0	0
15	8607-042BX	Blower Speed Terminal Block	X	X	X	X	X	X	X	X	X	X	X	X
16	8201-113BX	Dehumidification Logic Board				X	X	X				X	X	X
17	8201-176BX	Compressor Control Module	X	X	X	X	X	X	X	X	X	X	X	X
18	8407-068BX	Transformer	X	X		X	X	X	X	X		X	X	
18	8407-069BX	Transformer			X			X			X			X
19	8201-174BX	Phase Monitor		X	X		X	X		X	X		X	X
20	8552-079BX	Compressor Capacitor	X			X								
20	8552-057BX	Compressor Capacitor		X					X			X		
20	8552-005BX	Outdoor Motor Capacitor			X					X			X	
20	8552-004BX	Outdoor Motor Capacitor					X				X			X
21	8550-008BX	Capacitor Strap	X			X		X				X		
21	8550-003BX	Capacitor Strap		X	X		X	X		X	X		X	X
22	8551-004BX	Start Device (PTCR) (Kit = CMC-32)	0			0			0			0		
23	8401-034BX	Compressor Contactor	X			X		X				X		
23	8401-035BX	Compressor Contactor		X	X		X	X		X	X		X	X
NS	8615-037BX	Circuit Breaker 30A 2 Pole ①	0			0								
NS	8615-038BX	Circuit Breaker 35A 2 Pole ①						0				0		
NS	8615-051BX	Circuit Breaker 25A 3 Pole ①		0			0		0				0	
NS	8615-052BX	Circuit Breaker 30A 3 Pole ①									0			0
NS	8615-095BX	Toggle Disconnect			0			0			0			0
NS	4213-132	Wiring Diagram	X						X					
NS	4213-232	Wiring Diagram		X						X				
NS	4213-332	Wiring Diagram			X						X			
NS	4213-134	Wiring Diagram				X						X		
NS	4213-234	Wiring Diagram					X						X	
NS	4213-334	Wiring Diagram						X						X
NS	3000-1613BX	Blower Power Plug	X	X	X	X	X	X	X	X	X	X	X	X
NS	3000-1614BX	Blower Speed Plug							X	X	X	X	X	X
NS	3000-1690BX	Blower Speed Plug	X	X	X	X	X	X						
NS	3000-1222BX	Compressor Plug/Harness	X			X		X				X		
NS	3000-1230BX	Compressor Plug/Harness		X	X		X	X		X	X		X	X
NS	3003-176BX	Control Panel Wire Harness	X				X	X	X					
NS	3003-190BX	Control Panel Wire Harness					X	X					X	X
NS	3003-177BX	Control Panel Wire Harness		X	X				X	X				
NS	3003-189BX	Control Panel Wire Harness				X						X		
NS	3000-1608BX	Low Voltage Terminal Block Wire Harness	X	X	X	X	X	X	X	X	X	X	X	X

NS = Not Shown

X – Standard Component

O – Optional Component

① Circuit breakers listed are for units without electric heat, "0Z" models.  
See heater replacement parts manual for units with electric heat.

# CONTROL PANEL – STANDARD & DEHUMIDIFICATION

Dwg No.	Part Number	Description	W5SAF-A	W5SAF-B	W5SAF-C	W5SAF-DA	W5SAF-DB	W5SAF-DC
1	117-411BX	Control Panel	X	X	X	X	X	X
2	910-2108BX	Complete Low Voltage Box Assembly (Sheet metal, Terminal Strip, & Wire Harness)	X	X	X	X	X	X
3	135-394BX	Wire Shield	X	X	X	X	X	X
4	8611-140-3208BX	Cable Duct - 32.5"	X	X	X	X	X	X
5	8611-140-0608BX	Cable Duct - 6.5" x 1" wide	X	X	X	X	X	X
6	8611-244-0608BX	Cable Duct - 6.5" x 1.5" wide	X	X	X	X	X	X
7	8607-021BX	Low Voltage Terminal Strip - 8 term.	O	O	O	O	O	O
8	8607-071BX	Low Voltage Terminal Strip - 20 term.	X	X	X	X	X	X
9	3000-1524BX	Vent Jumper Plug (used when no vent option)	X	X	X	X	X	X
10	8201-130BX	Alarm Relay (Kit = CMA-42)	O	O	O	O	O	O
11	8201-130BX	Blower Speed Relay	X	X	X	X	X	X
12	8201-130BX	Dehumidification Control Relay				X	X	X
13	8201-130BX	Dirty Filter Relay (Kit = CMC-33)	O	O	O	O	O	O
14	8607-017BX	Terminal Block (LAC Kit = CMA-39)	O	O	O	O	O	O
15	8607-042BX	Blower Speed Terminal Block	X	X	X	X	X	X
17	8201-176BX	Compressor Control Module	X	X	X	X	X	X
18	8407-068BX	Transformer	X	X		X	X	
18	8407-069BX	Transformer			X			X
19	8201-174BX	Phase Monitor		X	X		X	X
20	8552-055BX	Compressor Capacitor	X			X		
20	8552-005BX	Outdoor Motor Capacitor		X			X	
20	8552-004BX	Outdoor Motor Capacitor			X			X
21	8550-008BX	Capacitor Strap	X			X		
21	8550-003BX	Capacitor Strap		X	X		X	X
22	8551-004BX	Start Device (PTCR)	O	O	O	O	O	O
23	8401-034BX	Compressor Contactor	X			X		
23	8401-035BX	Compressor Contactor		X	X		X	X
24	8201-130BX	Second Stage Dehumidification Relay				X	X	X
NS	8615-040BX	Circuit Breaker 50A 2 Pole ①	O			O		
NS	8615-052BX	Circuit Breaker 30A 3 Pole ①		O			O	
NS	8615-095BX	Toggle Disconnect			O			O
NS	4213-132	Wiring Diagram	X					
NS	4213-232	Wiring Diagram		X				
NS	4213-332	Wiring Diagram			X			
NS	4213-134	Wiring Diagram				X		
NS	4213-234	Wiring Diagram					X	
NS	4213-334	Wiring Diagram						X
NS	3000-1613BX	Blower Power Plug	X	X	X	X	X	X
NS	3000-1614BX	Blower Speed Plug	X	X	X	X	X	X
NS	3000-1222BX	Compressor Plug/Harness	X			X		
NS	3000-1230BX	Compressor Plug/Harness		X	X		X	X
NS	3000-1223BX	Staging Harness	X	X	X	X	X	X
NS	3003-176BX	Control Panel Wire Harness	X					
NS	3003-190BX	Control Panel Wire Harness		X	X			
NS	3003-177BX	Control Panel Wire Harness				X		
NS	3003-189BX	Control Panel Wire Harness					X	X
NS	3000-1608BX	Low Voltage Terminal Block Wire Harness	X	X	X	X	X	X

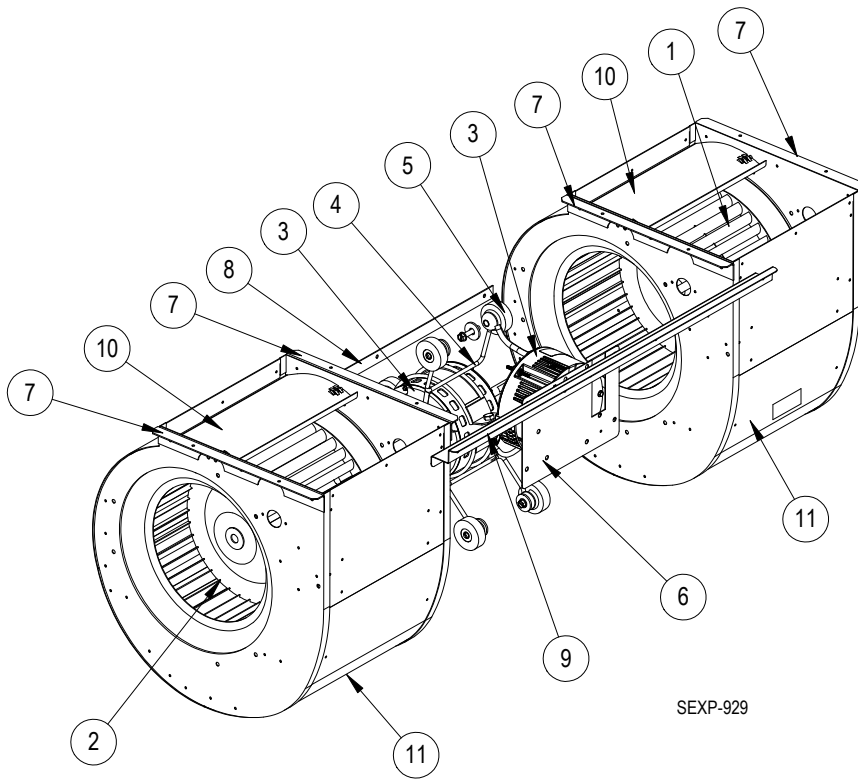
NS = Not Shown

X – Standard Component

① Circuit breakers listed are for units without electric heat, "OZ" models. See heater replacement parts manual for units with electric heat.

O – Optional Component

# BLOWER ASSEMBLY



Dwg No.	Part Number	Description	900-387-0290BX	900-388-0289BX	900-368-0288BX	900-368-0287BX	900-369-0286BX	900-369-0285BX
1	5152-057BX	9 Inch Wheel (CW)	X	X				
1	5152-011BX	10 Inch Wheel (CW)			X	X	X	X
2	5152-058BX	9 Inch Wheel (CCW)	X	X				
2	5152-012BX	10 Inch Wheel (CCW)			X	X	X	X
3	8106-068-0290BX	Programmed Blower Motor & Control (230/208V)	X					
3	8106-069-0289BX	Programmed Blower Motor & Control (460V)		X				
3	8107-028-0288BX	Programmed Blower Motor & Control (230/208V)			X			
3	8107-028-0287BX	Programmed Blower Motor & Control (230/208V)				X		
3	8107-029-0286BX	Programmed Blower Motor & Control (460V)					X	
3	8107-029-0285BX	Programmed Blower Motor & Control (460V)						X
3	C8106-068-0290	Programmed Control Only (230/208V)	0					
3	C8106-069-0289	Programmed Control Only (460V)		0				
3	C8107-028-0288	Programmed Control Only (230/208V)			0			
3	C8107-028-0287	Programmed Control Only (230/208V)				0		
3	C8107-029-0286	Programmed Control Only (460V)					0	
3	C8107-029-0285	Programmed Control Only (460V)						0
4	8200-040BX	Motor Mount	X	X	X	X	X	X
5	5451-011	Grommets	6	6	6	6	6	6
6	112-775BX	Motor Control Bracket	X	X	X	X	X	X
7	105-880BX	Side Angle	4	4	4	4	4	4
8	105-881BX	Back Brace	X	X	X	X	X	X
9	103-541BX	Front Mounting Offset	X	X	X	X	X	X
10	144-166BX	Diffuser	2	2	2	2	2	2
11	151-101BX	Blower Housing	2	2	2	2	2	2

X – Standard Component  
O – Optional Component



---

# Supplemental Instructions

---

## Models:

W3SAFD W4SAFD W5SAFD

---

This model provides a unique dehumidification circuit for periods of low outdoor ambient temperature and high indoor humidity conditions.

Refer to Specification Sheet S3658 for the standard features of the base units and this manual for electrical data.

### Dehumidification Circuit

The dehumidification circuit incorporates an independent heat exchanger coil in the supply air stream. This coil reheats the supply air after it passes over the cooling coil without requiring the electric resistance heater to be used for reheat purposes. This results in very high mechanical dehumidification capability from the air conditioner on demand without using electric resistance reheat.

The dehumidification refrigerant reheat circuit is controlled by a dehumidification valve directing the refrigerant gas to the normal condenser during periods when standard air conditioning is required. During periods of high indoor humidity, a humidistat senses the need for mechanical dehumidification. It then energizes both the compressor circuit and the dehumidification valve, thus directing the hot refrigerant discharge gas into a separate desuperheating condenser circuit, which reheats the conditioned air before it is delivered to the room. The refrigerant gas is then routed from the desuperheating condenser to the system condenser for further heat transfer. When the humidistat is satisfied, the system automatically switches off. The result is separate humidity control at minimum operating cost.

### Dehumidification Sequence of Operation

Dehumidification is controlled through the thermostat (if capable) or through a separate humidistat. On a call for dehumidification mode of operation, the compressor and dehumidification valve of the unit are energized through circuit R - D to provide dehumidification. Dehumidification will continue until the humidistat is satisfied.

A cooling call takes precedence over a dehumidification call as long as the cooling call is present. A heating call takes precedence over a dehumidification call as long as the heating call is present.

Refer to the table on page 13 for a full list of outputs that can be expected for different input combinations.

### Balanced Climate™ Mode

It is recommended to enable Balanced Climate mode and utilize a 2-stage thermostat to enhance the dehumidification performance and comfort. To activate this mode, the jumper between Y1 and Y2 on the low voltage terminal strip needs to be removed and the unconnected purple wire laying in the cable duct needs to be pulled out and placed on the terminal block so that it connects to the yellow wire from the outdoor temperature switch. Refer to the unit wiring diagram for clarity.

**NOTE:** *In units with dehumidification, never have both the Balanced Climate jumper in place and the outdoor temperature switch connected at the same time!*



Climate Control Solutions

Bard Manufacturing Company, Inc.  
Bryan, Ohio 43506  
www.bardhvac.com

Manual: 7960-960  
Supersedes: **NEW**  
Date: 11-20-24

This mode will allow the indoor blower to run at a reduced airflow on the first stage of cooling. A 2-stage thermostat connected to Y2 will then allow the airflow to return to normal rated speed if the call for dehumidification or cooling is not satisfied within the allotted time frame specified by the thermostat. See latest revision of unit installation instructions for more information regarding the Balanced Climate operation.


## Electronic Expansion Valve

### Operation

This model employs an electronic expansion valve (EEV) which meters the refrigerant to the evaporator. The EEV is made of a stepper motor that is controlled with a step output from the controller. The valve is capable of 480 steps which drives a needle valve that in turn regulates the flow of refrigerant. The EEV allows for tighter control and better capacity management in varying operating conditions than a standard TXV. The EEV system consists of the electronic valve and stator, control board, relay, suction temperature sensor and suction pressure transducer. The pressure transducer and temperature sensor monitor the suction line to provide real time data to the control board so that a real time superheat can be calculated. This then determines the EEV position. The controller is sent to maintain around 13° superheat. The relay is used to activate the EEV system's controller anytime that the compressor is energized.

!
**WARNING/AVERTISSEMENT**

- Exposure to high pressure refrigerant hazard.
- This unit is equipped with an electronic expansion valve. In order to fully recover refrigerant or evacuate the system during repairs, be sure to use service tool 2151-021 to manually open the electronic expansion valve or be sure to recover and evacuate from all service ports; suction, liquid, and discharge.
- Failure to do so could result in eye injuries and/or refrigerant burns.
- Exposition à un risque de réfrigérant à haute pression.
- Cet appareil est équipé d'un détendeur électronique. Afin de récupérer complètement le réfrigérant ou d'évacuer le système pendant les réparations, assurez-vous d'utiliser l'outil de service 2151-021 pour ouvrir manuellement le détendeur électronique ou assurez-vous de récupérer et d'évacuer de tous les ports de service: aspiration, liquide et refoulement.
- Ne pas le faire pourrait entraîner des blessures aux yeux et / ou des brûlures de réfrigérant.



7961-953

### EEV Instructions for Vacuuming, Reclaiming and Charging Unit

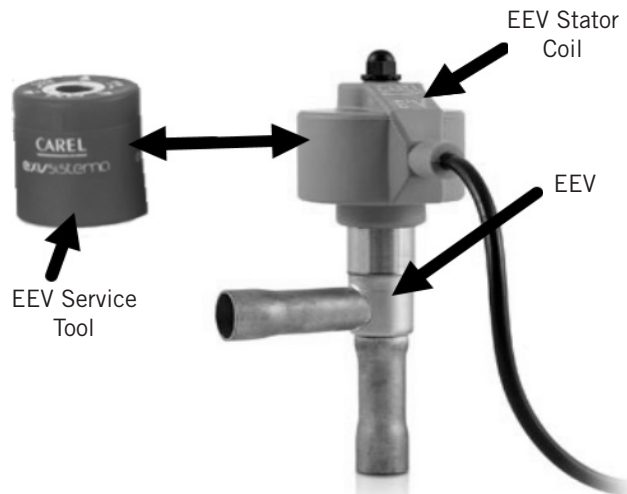
**NOTE:** Refer to A2L Refrigerant Safety Manual 2100-810 before vacuuming, reclaiming and charging the unit.

The electronic expansion valve moves to a closed position when there is no call to control. In order to pull a complete vacuum, fully reclaim the system or charge the unit, connections to all service ports—suction, liquid and discharge—need to be utilized or the valve needs to be manually opened first. The valve can be opened manually using the magnetic EEV service tool (Bard Part # 2151-021) shown in Figure 1. To do this, remove the EEV stator coil (red color with retaining

nut on top), slide the magnetic tool over the shaft where the stator was removed and turn in a clockwise direction to open the valve to the full open position (directional arrows are provided on the tool).

Reapply the EEV stator coil and retaining nut once complete. Upon powering the unit back up, the control board will automatically drive the EEV back to the fully shut position. Once the compressor starts, the control board will again modulate the EEV position to control the system superheat.

**FIGURE 1**  
**Electronic Expansion Valve (EEV) and Service Tool**



## Troubleshooting the Electronic Expansion Valve

The control board has two status LEDs.

- The green LED should be lit anytime that the board has power and the control is functioning.
- The red LED is to show that an alarm is present.

See Table 1 for a guide to know where to start troubleshooting the EEV. Refer to the appropriate unit replacement parts manual for any parts that are needed.

### Control Board

Check that the controller is getting 24VAC signal (GO 24VAC Hot and G 24VAC common). Reference unit wiring diagram for proper connections. If 24V is present but the green LED is not lit, replace the controller. If the green LED is now lit but the superheat is still not being maintained, troubleshoot the relay to check that the DI is connected to G; refer to **Relay in EEV Control Box** on page 3.

### Electronic Expansion Valve

Check to see if valve can be moved by manually moving the stepper motor using the EEV service tool shown in Figure 1 (Bard Part # 2151-021). If valve still does not control, check the transducer and thermistor sensors as

**TABLE 1**  
**Electronic Expansion Valve Troubleshooting**

Problem	Probable Cause	Troubleshoot
The green LED is not lit.	Controller not receiving 24VAC signal.	Control Board
The green LED is lit, but superheat is not being maintained.	The relay is not closing the controller's DI connection to ground.	Relay
The red LED is flashing and EEV is not controlling superheat properly (13° superheat). One of the following is likely the fault:		
1. Low superheat is detected and the controller is taking steps to protect the system by closing the valve.	Stator is broken or connected incorrectly.	Stator
	Valve is stuck open.	EEV Valve
2. Suction temperature sensor error.	Poor connection of sensor or faulty sensor.	Thermistor
3. Suction pressure transducer error.	Pressure transducer wiring incorrect or faulty transducer.	Transducer
The red LED is on steady.	The operating parameters have been damaged.	Replace Control Board

described on page 4. If sensors are good, replace the valve.

**Relay in EEV Control Box**

Contacts NO to DI and COM to G must be closed for EEV control to start controlling superheat. Check that the relay is getting 24VAC. Reference unit wiring diagram for proper connections. If 24V is present, measure the resistance between COM and NO; it should be 0 ohms when the relay is getting 24V. If the resistance is out of range, replace the relay.

**Stator Coil**

Disconnect the stator from the valve and the control and measure the resistance of the windings using an electrical tester. The resistance of both windings should be around 40 ohms +/- 10%. The four wire sets that will have resistance between them are: White and red, green and red, yellow and purple, blue and purple. If the resistance falls outside these values, replace the stator.

**Transducer Sensor**

1. Check that there is 5VDC Nominal between the red and black wires going to the transducer.
2. Check the signal voltage between the blue and black wires (0.5-4.5VDC Actual). The following formula and Figure 2 can be used to determine if the transducer's voltage to pressure ratio is within range. Replace transducer if out of range.
3. Check to ensure wires are correctly connected as follows:

Blue wire = pin 1 of controller plug to pin C on transducer plug

Red wire = pin 2 of controller plug to pin B on transducer plug

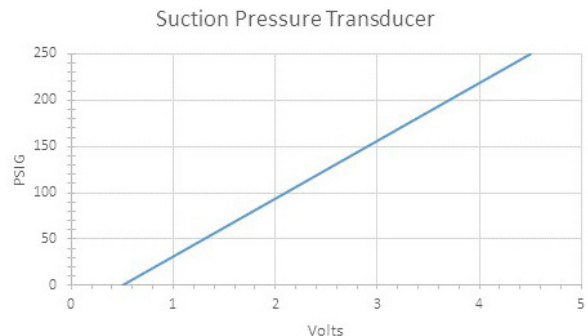
Black wire = pin 3 of controller plug to pin A on transducer plug

4. Check continuity of all three wires from transducer plug to controller plug. Replace wires if poor connection in any wire.

Formula for Tech:

$$(\text{Measured Pressure} \times .016) + .5 = \text{Expected Transducer Signal Voltage (see Figure 2)}$$

**FIGURE 2**  
**Voltage to Pressure: Suction Pressure Transducer**



### Thermistor Sensor

1. Make a visual check for broken wire insulation, broken wires or cracked epoxy material.
2. Disconnect 10k ohm NTC thermistor from the EEV control box.
3. Use an ohmmeter to measure the resistance between the two connectors. Also use ohmmeter to check for short or open.
4. Compare the resistance reading to Table 2. Use sensor ambient temperature. (Tolerance of part is  $\pm 10\%$ .)
5. If sensor is out of tolerance, shorted, open or reads very low ohms, it should be replaced.

**TABLE 2**  
**10K Ohm NTC Sensor: Temperature/Resistance**

Temperature		Resistance	Temperature		Resistance	Temperature		Resistance	Temperature		Resistance
F	C	$\Omega$	F	C	$\Omega$	F	C	$\Omega$	F	C	$\Omega$
-40	-40	188,500	28.4	-2	29,730	96.8	36	6,700	165.2	74	1,980
-38.2	-39	178,500	30.2	-1	28,480	98.6	37	6,470	167	75	1,920
-36.4	-38	169,000	32	0	27,280	100.4	38	6,250	168.8	76	1,870
-34.6	-37	160,200	33.8	1	26,130	102.2	39	6,030	170.6	77	1,820
-32.8	-36	151,900	35.6	2	25,030	104	40	5,830	172.4	78	1,770
-31	-35	144,100	37.4	3	23,990	105.8	41	5,630	174.2	79	1,920
-29.2	-34	136,700	39.2	4	23,000	107.6	42	5,440	176	80	1,670
-27.4	-33	129,800	41	5	22,050	109.4	43	5,260	177.8	81	1,620
-25.6	-32	123,300	42.8	6	21,150	111.2	44	5,080	179.6	82	1,580
-23.8	-31	117,100	44.6	7	20,300	113	45	4,910	181.4	83	1,530
-22	-30	111,300	46.4	8	19,480	114.8	46	4,750	183.2	84	1,490
-20.2	-29	105,700	48.2	9	18,700	116.6	47	4,590	185	85	1,450
-18.4	-28	100,500	50	10	17,960	118.4	48	4,440	186.8	86	1,441
-16.6	-27	95,520	51.8	11	17,240	120.2	49	4,300	188.6	87	1,370
-14.8	-26	90,840	53.6	12	16,560	122	50	4,160	190.4	88	1,340
-13	-25	86,430	55.4	13	15,900	123.8	51	4,030	192.2	89	1,300
-11.2	-24	82,260	57.2	14	15,280	125.6	52	3,900	194	90	1,270
-9.4	-23	78,330	59	15	14,690	127.4	53	3,770	195.8	91	1,230
-7.6	-22	74,610	60.8	16	14,120	129.2	54	3,650	197.6	92	1,200
-5.8	-21	71,100	62.6	17	13,580	131	55	3,540	199.4	93	1,170
-4	-20	67,770	64.4	18	13,060	132.8	56	3,430	201.2	94	1,140
-2.2	-19	64,570	66.2	19	12,560	134.6	57	3,320	203	95	1,110
-0.4	-18	61,540	68	20	12,090	136.4	58	3,220	204.8	96	1,080
1.4	-17	58,680	69.8	21	11,630	138.2	59	3,120	206.6	97	1,050
3.2	-16	55,970	71.6	22	11,200	140	60	3,020	208.4	98	1,020
5	-15	53,410	73.4	23	10,780	141.8	61	2,930	210.2	99	1,000
6.8	-14	50,980	75.2	24	10,380	143.6	62	2,840	212	100	970
8.6	-13	48,680	77	25	10,000	145.4	63	2,750			
10.4	-12	46,500	78.8	26	9,630	147.2	64	2,670			
12.2	-11	44,430	80.6	27	9,280	149	65	2,590			
14	-10	42,470	82.4	28	8,940	150.8	66	2,510			
15.8	-9	40,570	84.2	29	8,620	152.6	67	2,440			
17.6	-8	38,770	86	30	8,310	154.4	68	2,360			
19.4	-7	37,060	87.8	31	8,010	156.2	69	2,300			
21.2	-6	35,440	89.6	32	7,730	158	70	2,230			
23	-5	33,900	91.4	33	7,450	159.8	71	2,160			
24.8	-4	32,440	93.2	34	7,190	161.6	72	2,100			
26.6	-3	31,050	95	35	6,940	163.4	73	2,040			

### W3SAFD Cooling and Dehumidification Application Data<sup>1</sup>

DB/WB <sup>2</sup>	OD Temp.	65°F <sup>3</sup>		75°F		85°F		95°F	
	Mode	A/C	Dehum	A/C	Dehum	A/C	Dehum	A/C	Dehum
<b>75/64.1 (55% RH)</b>	Total Cooling Btuh	41,100	5,500	38,900	12,500	36,600	13,300	34,100	8,100
	Sensible Btuh	27,400	-3,200	26,400	1,500	25,300	2,100	24,000	-1,600
	Latent Btuh	13,700	8,700	12,500	11,000	11,300	11,200	10,100	9,700
	Lbs. H2O/hr.	12.9	8.2	11.8	10.4	10.7	10.6	9.5	9.2
	Supply Air DB	53.3	78.8	54.1	73.7	55.0	73.2	56.0	77.3
	Supply Air WB	51.9	62.2	52.6	59.4	53.4	59.0	54.3	61.0
	Suction PSIG <sup>4</sup>	118	110	120	112	123	114	126	117
	Discharge PSIG <sup>4</sup>	245	310	282	271	323	266	369	296
<b>75/65.5 (60% RH)</b>	Total Cooling Btuh	41,900	6,600	39,700	17,200	37,400	14,400	34,900	9,200
	Sensible Btuh	25,900	-4,000	24,800	3,300	23,800	1,300	22,500	-2,400
	Latent Btuh	16,000	10,600	14,900	13,900	13,600	13,100	12,400	11,600
	Lbs. H2O/hr.	15.1	10.0	14.1	13.1	12.8	12.4	11.7	10.9
	Supply Air DB	54.5	79.7	55.3	71.8	56.2	74.1	57.2	78.2
	Supply Air WB	53.3	63.1	54.0	58.8	54.8	60.0	55.7	62.0
	Suction PSIG <sup>4</sup>	121	113	123	115	125	117	128	120
	Discharge PSIG <sup>4</sup>	246	312	283	253	324	268	370	297
<b>75/66.7 (65% RH)</b>	Total Cooling Btuh	42,700	7,700	40,500	18,300	38,100	15,500	35,700	10,300
	Sensible Btuh	24,400	-4,700	23,300	2,500	22,200	500	21,000	-3,200
	Latent Btuh	18,300	12,400	17,200	15,800	15,900	15,000	14,700	13,500
	Lbs. H2O/hr.	17.3	11.7	16.2	14.9	15.0	14.2	13.9	12.7
	Supply Air DB	55.7	80.6	56.5	72.7	57.4	75.0	58.4	79.0
	Supply Air WB	54.6	64.0	55.3	59.8	56.1	60.9	57.0	62.9
	Suction PSIG <sup>4</sup>	123	116	125	117	128	119	130	122
	Discharge PSIG <sup>4</sup>	247	313	284	255	325	270	371	299
<b>75/68 (70% RH)</b>	Total Cooling Btuh	43,400	8,800	41,200	19,400	38,900	16,600	36,400	11,400
	Sensible Btuh	22,900	-5,500	21,800	1,700	20,700	-300	19,500	-4,000
	Latent Btuh	20,500	14,300	19,400	17,700	18,200	16,900	16,900	15,400
	Lbs. H2O/hr.	19.3	13.5	18.3	16.7	17.2	15.9	15.9	14.5
	Supply Air DB	56.9	81.4	57.7	73.5	58.6	75.8	59.7	79.9
	Supply Air WB	56.0	64.9	56.7	60.7	57.5	61.8	58.4	63.8
	Suction PSIG <sup>4</sup>	126	118	128	120	130	122	133	125
	Discharge PSIG <sup>4</sup>	247	315	285	257	326	271	371	301

<sup>1</sup> Values listed are with ventilation package disabled

<sup>2</sup> Return air temperature °F @ Rated SCFM

<sup>3</sup> Below 50°F, unit requires a factory- or field-installed low ambient control.

<sup>4</sup> Suction pressure +/- 4 psi, Discharge pressure +/- 10 psi

**W4SAFD Cooling and Dehumidification Application Data<sup>1</sup>**

DB/WB <sup>2</sup>	OD Temp.	65°F <sup>3</sup>		75°F		85°F		95°F	
	Mode	A/C	Dehum	A/C	Dehum	A/C	Dehum	A/C	Dehum
<b>75/64.1 (55% RH)</b>	Total Cooling Btuh	54,500	15,700	51,800	17,600	48,400	15,500	44,400	9,400
	Sensible Btuh	36,900	2,100	35,800	4,200	34,300	3,100	32,700	-1,300
	Latent Btuh	17,600	13,600	16,000	13,400	14,100	12,400	11,700	10,700
	Lbs. H2O/hr.	16.6	12.8	15.1	12.6	13.3	11.7	11.0	10.1
	Supply Air DB	53.6	73.6	54.4	71.7	55.2	72.6	56.0	76.4
	Supply Air WB	52.4	59.5	53.0	58.9	53.8	59.5	54.7	61.4
	Suction PSIG <sup>4</sup>	116	105	116	106	119	109	123	115
	Discharge PSIG <sup>4</sup>	261	291	287	276	329	284	387	315
<b>75/65.5 (60% RH)</b>	Total Cooling Btuh	55,200	17,000	52,500	21,300	49,100	16,900	45,100	10,800
	Sensible Btuh	34,700	1,000	33,400	5,000	32,100	2,000	30,500	-2,400
	Latent Btuh	20,500	16,000	19,100	16,300	17,000	14,900	14,600	13,200
	Lbs. H2O/hr.	19.3	15.1	18.0	15.4	16.0	14.1	13.8	12.5
	Supply Air DB	54.9	74.6	55.6	71.2	56.4	73.6	57.3	77.4
	Supply Air WB	53.8	60.6	54.5	59.3	55.3	60.6	56.2	62.5
	Suction PSIG <sup>4</sup>	118	107	119	109	122	112	126	117
	Discharge PSIG <sup>4</sup>	266	293	292	267	335	287	393	318
<b>75/66.7 (65% RH)</b>	Total Cooling Btuh	55,900	18,400	53,200	22,600	49,800	18,200	45,800	12,100
	Sensible Btuh	32,500	--	31,200	3,900	29,900	1,000	28,300	-3,500
	Latent Btuh	23,400	18,400	22,000	18,700	19,900	17,200	17,500	15,600
	Lbs. H2O/hr.	22.1	17.4	20.8	17.6	18.8	16.2	16.5	14.7
	Supply Air DB	56.1	75.6	56.9	72.2	57.7	74.6	58.6	78.4
	Supply Air WB	55.2	61.7	55.9	60.4	56.7	61.7	57.6	63.5
	Suction PSIG <sup>4</sup>	121	110	122	112	124	114	129	120
	Discharge PSIG <sup>4</sup>	271	296	298	270	340	289	398	320
<b>75/68 (70% RH)</b>	Total Cooling Btuh	56,600	19,700	53,900	24,000	50,500	19,500	46,500	13,400
	Sensible Btuh	30,400	-1,100	29,000	2,800	27,700	-100	26,100	-4,500
	Latent Btuh	26,200	20,800	24,900	21,200	22,800	19,600	20,400	17,900
	Lbs. H2O/hr.	24.7	19.6	23.5	20.0	21.5	18.5	19.2	16.9
	Supply Air DB	57.4	76.6	58.2	73.2	59.0	75.6	59.8	79.4
	Supply Air WB	56.6	62.7	57.3	61.5	58.1	62.8	59.0	64.6
	Suction PSIG <sup>4</sup>	124	112	125	114	127	117	132	122
	Discharge PSIG <sup>4</sup>	277	298	303	272	345	291	403	322

<sup>1</sup> Values listed are with ventilation package disabled

<sup>2</sup> Return air temperature °F @ Rated SCFM

<sup>3</sup> Below 50°F, unit requires a factory- or field-installed low ambient control.

<sup>4</sup> Suction pressure +/- 4 psi, Discharge pressure +/- 10 psi

**W5SAFD Cooling and Dehumidification Application Data<sup>1</sup>**

DB/WB <sup>2</sup>	OD Temp.	65°F <sup>3</sup>		75°F		85°F		95°F	
	Mode	A/C	Dehum	A/C	Dehum	A/C	Dehum	A/C	Dehum
<b>75/64.1 (55% RH)</b>	Total Cooling Btuh	66,100	15,100	63,300	18,500	60,100	16,800	56,700	10,200
	Sensible Btuh	44,300	5,500	42,900	5,700	41,500	4,600	40,400	2,200
	Latent Btuh	21,800	9,600	20,400	12,800	18,600	12,200	16,300	8,000
	Lbs. H2O/hr.	20.6	9.1	19.2	12.1	17.5	11.5	15.4	7.5
	Supply Air DB	52.3	63.7	53.0	86.0	53.6	84.2	54.2	58.5
	Supply Air WB	51.4	54.0	52.0	72.3	52.6	70.5	53.3	48.7
	Suction PSIG <sup>4</sup>	120	109	121	156	124	155	127	108
	Discharge PSIG <sup>4</sup>	280	249	320	343	363	340	411	239
<b>75/65.5 (60% RH)</b>	Total Cooling Btuh	67,400	16,500	64,500	22,800	61,300	18,300	57,900	11,600
	Sensible Btuh	42,200	4,300	40,400	7,600	39,300	3,400	38,200	900
	Latent Btuh	25,200	12,200	24,100	15,200	22,000	14,900	19,700	10,700
	Lbs. H2O/hr.	23.8	11.5	22.7	14.3	20.8	14.1	18.6	10.1
	Supply Air DB	53.5	63.6	54.2	70.1	54.9	84.1	55.5	58.3
	Supply Air WB	52.7	58.0	53.3	62.6	53.9	74.5	54.6	52.7
	Suction PSIG <sup>4</sup>	101	112	102	131	130	158	126	111
	Discharge PSIG <sup>4</sup>	201	252	241	262	305	342	333	242
<b>75/66.7 (65% RH)</b>	Total Cooling Btuh	68,600	18,000	65,700	24,200	62,600	19,700	59,100	13,100
	Sensible Btuh	40,000	3,000	38,200	6,400	37,200	2,100	36,000	-300
	Latent Btuh	28,600	15,000	27,500	17,800	25,400	17,600	23,100	13,400
	Lbs. H2O/hr.	27.0	14.2	25.9	16.8	24.0	16.6	21.8	12.6
	Supply Air DB	54.7	63.4	55.4	70.0	56.1	84.0	56.7	58.2
	Supply Air WB	54.1	62.0	54.7	66.6	55.3	78.5	56.0	56.7
	Suction PSIG <sup>4</sup>	81	115	83	134	110	161	107	114
	Discharge PSIG <sup>4</sup>	123	254	162	265	227	345	254	244
<b>75/68 (70% RH)</b>	Total Cooling Btuh	69,800	19,400	67,000	25,700	63,800	21,200	60,400	14,500
	Sensible Btuh	37,800	1,800	36,000	5,100	35,000	900	33,800	-1,600
	Latent Btuh	32,000	17,600	31,000	20,600	28,800	20,300	26,600	16,100
	Lbs. H2O/hr.	30.2	16.6	29.2	19.4	27.2	19.2	25.1	15.2
	Supply Air DB	56.0	63.3	56.7	69.8	57.3	83.8	57.9	58.0
	Supply Air WB	55.5	65.9	56.0	70.6	56.7	82.5	57.3	60.6
	Suction PSIG <sup>4</sup>	62	118	64	137	91	164	88	117
	Discharge PSIG <sup>4</sup>	44	257	83	267	148	347	175	247

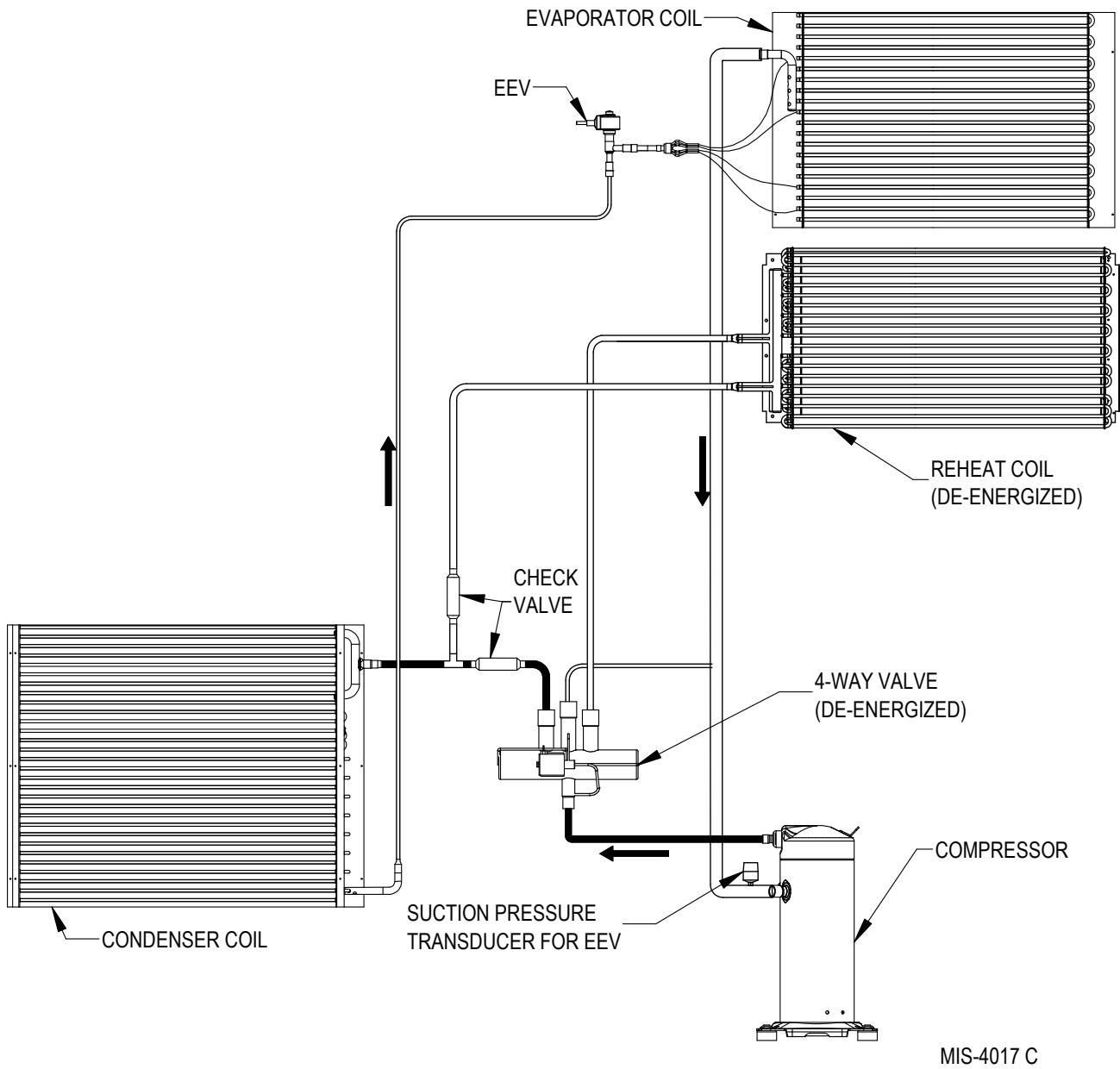
<sup>1</sup> Values listed are with ventilation package disabled

<sup>2</sup> Return air temperature °F @ Rated SCFM

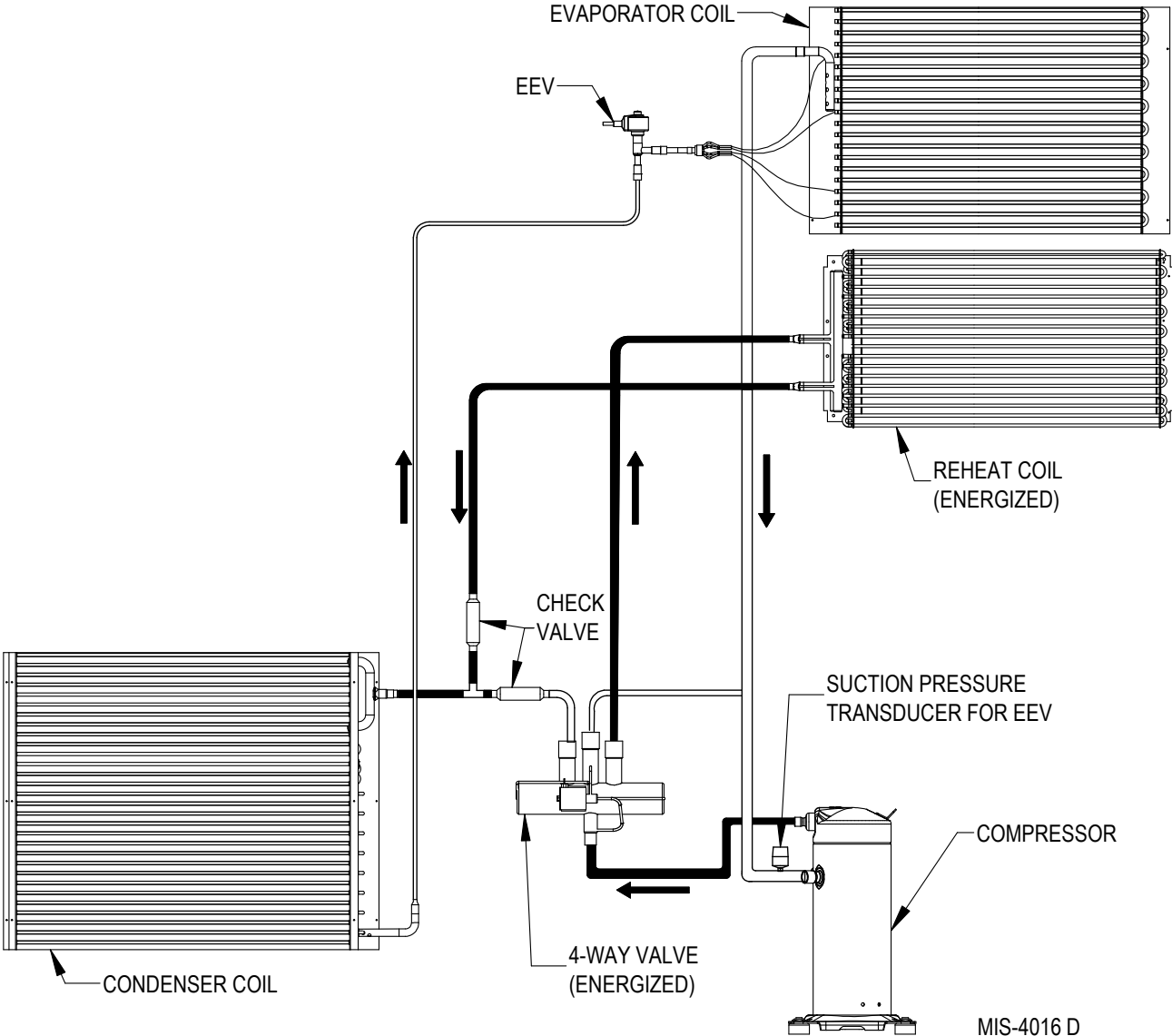
<sup>3</sup> Below 50°F, unit requires a factory- or field-installed low ambient control.

<sup>4</sup> Suction pressure +/- 4 psi, Discharge pressure +/- 10 psi

# Air Conditioning Mode Circuit Diagram



# Dehumidification Mode Circuit Diagram



**TABLE 3  
Dehumidification Relay Logic Board**

Energize on Unit Terminal Strip	Mode	Occupied/Unoccupied	Inputs to the Board				Outputs from the Board	
			Y	W2	A1	D	TWV	YO
Y1, G	Cooling	Unoccupied	X					X
Y1, G, A	Cooling	Occupied	X		X			X
Y1, G, A, D	Cooling w/Dehum ①	Occupied	X		X	X		X
Y1, G, D	Cooling w/Dehum ①	Unoccupied	X			X		X
G, B/W1	1st Stage Electric Heat	Unoccupied		X				
G, B/W1, A	1st Stage Electric Heat	Occupied		X	X			
G, B/W1, A, D	1st Stage Electric Heat w/Dehum ②	Occupied		X	X			
G, B/W1, D	1st Stage Electric Heat w/Dehum ②	Unoccupied		X				
G, B/W1, W2	2nd Stage Electric Heat	Unoccupied		X				
G, B/W1, W2, A	2nd Stage Electric Heat	Occupied		X	X			
G, B/W1, W2, A, D	2nd Stage Electric Heat and Dehum ②	Occupied		X	X			
G, B/W1, W2, D	2nd Stage Electric Heat and Dehum ②	Unoccupied		X				
D	Dehum	Unoccupied				X	X ③	X ③
D, A	Dehum	Occupied			X	X	X	X

① Cooling takes precedence over dehumidification. A cooling call cancels dehumidification.

② The dehumidification input “D” is not received by the board because of an isolation relay that is energized by the call for heating (B/W1). Thus, the heating call (B/W1) always takes precedence over dehumidification.

③ The relay logic board has a jumper (J1) on it to choose between “any-time dehumidification” and “occupied dehumidification”. The factory default is P1-P2. With the jumper in the P1-P2 position, dehumidification is available any time there is a “D” input to the relay logic board. With the jumper in the P2-P3 position, dehumidification is available when there is an occupancy signal to the “A1” terminal, “D” would also need to be energized to dehumidify.

Refer to sequence of operation. In most cases cooling and heating modes take priority over dehumidification.

**TABLE 4**  
**Electrical Specifications**

Model	Rated Volts & Phase	No. Field Power Circuits	Single Circuit		Dual Circuit			
			① Minimum Circuit Ampacity	② Maximum External Fuse or Circuit Breaker	① Minimum Circuit Ampacity		② Maximum External Fuse or Circuit Breaker	
					Circuit A	Circuit B	Circuit A	Circuit B
W3SAFDA00, AOZ A05 A10 A15	230/208-1	1 1 1 1 or 2	23 31 57 83	30 35 60 90	57	26	60	30
W3SAFDB00, BOZ B05 B09 B15	230/208-3	1 1 1 1	18 20 32 50	20 20 35 50				
W3SAFDC00, COZ C05 C09 C15	460-3	1 1 1 1	9 10 16 25	15 15 20 25				
W4SAFDA00, AOZ A05 A10 A15	230/208-1	1 1 1 1 or 2	31 33 59 85	35 35 60 90	59	26	60	30
W4SAFDB00, BOZ B05 B09	230/208-3	1 1 1	23 23 34	30 30 35				
W4SAFDC00, COZ C05 C09	460-3	1 1 1	13 13 17	15 15 20				
W5SAFDA00, AOZ A05 A10 A15	230/208-1	1 1 1 1 or 2	40 40 60 86	50 50 60 90	60	26	60	30
W5SAFDB00, BOZ B09 B15	230/208-3	1 1 1	26 35 53	30 35 60				
W5SAFDC00, COZ C09 C15	460-3	1 1 1	13 18 27	15 20 30				

① These "Minimum Circuit Ampacity" values are to be used for sizing the field power conductors. Refer to the National Electrical code (latest version), Article 310 for power conductor sizing. **CAUTION:** When more than one field power circuit is run through one conduit, the conductors must be derated. Pay special attention to note 8 of Table 310 regarding Ampacity Adjustment Factors when more than three (3) current carrying conductors are in a raceway.

② Maximum size of the time delay fuse or circuit breaker for protection of field wiring conductors.

**NOTE:** The Maximum Overcurrent Protection (MOCP) value listed is the maximum value as per UL 60335 calculations for MOCP (branch-circuit conductor sizes in this chart are based on this MOCP). The actual factory-installed overcurrent protective device (circuit breaker) in this model may be lower than the maximum UL 60335 allowable MOCP value, but still above the UL 60335 minimum calculated value or Minimum Circuit Ampacity (MCA) listed.

**IMPORTANT:** While this electrical data is presented as a guide, it is important to electrically connect properly sized fuses and conductor wires in accordance with the National Electrical Code and all local codes.





Climate Control Solutions

# Limited Warranty

For units applied within the United States, Puerto Rico,  
US Virgin Islands, Guam, Canada and Mexico

## Limited Warranty To Original Purchaser:

Bard Manufacturing Company, Inc. Bryan, Ohio 43506 warrants to you, the original purchaser, that your Bard product will be free from defects in materials and workmanship when used under normal conditions from the installation date through the time periods outlined in the "Duration of Warranty" section (see reverse side).

## Proof Of Purchase:

You must be able to show us the date on which you purchased your product when you make a claim under this warranty. Your owner's registration card filed online at [www.wallmountwarranty.com](http://www.wallmountwarranty.com) or your contractor's invoice, bill of sale, or similar document is sufficient at time of warranty claim. This must be registered within 90 days of installation. If you can not show us the actual date of purchase, the time periods in this warranty will start on the date that we shipped your Bard product from our factory.

## What This Warranty Does Not Cover: (Also see Duration of Warranty on reverse side.)

This warranty does not cover defects or damage caused by:

1. Alterations not approved by Bard; improper installation (including over or under sizing), improper repairs, or servicing; or improper parts and accessories not supplied by Bard.
2. Misuse or failure to follow installation and operating instructions (including failure to perform preventative maintenance) or limitations on the rating plate. This includes failure to use low ambient controls on all applications requiring compressor operation in cooling mode below 60F outdoor ambient.
3. Any corrosion from operation in a corrosive atmosphere (examples: acids, halogenated hydrocarbons or environmental conditions).
4. Parts that must be replaced periodically (such as filters, mist eliminators, ERV belts, pile seals, etc.).
5. Improper fuel or electrical supply (such as low voltage, voltage transients, power interruption, and units on generators with no brownout protection).
6. Accidents or other events beyond our reasonable control (such as storm, fire, or transportation damage).
7. Defects that happen after
  - (a) Anyone has tampered with the product.
  - (b) The product has been improperly serviced according to accepted trade practices;
  - (c) The product has been moved from its original place of installation; or,
  - (d) The product has been damaged by an event beyond Bard's control (See also No. 5 above).
8. Consequential damages (such as increased living expenses while the product is being repaired). Some states do not allow the exclusion or limitation of incidental or consequential damages, so the above limitation or exclusion may not apply to you.
9. This warranty has certain limitations for units installed on over-the-road trucks, vans and trailers. (See reverse side.)
10. Cost of service call at installation site to diagnose causes of trouble, labor to replace defective component or transportation costs for replacement parts.
11. This Limited Warranty does not apply to products installed or operated outside of the US, Puerto Rico, US Virgin Islands, Guam, Canada and Mexico. Units operated in coastal areas where the operating environment is exposed to airborne saline particles (typically 5 miles from coast line) must have corrosion protection or warranty claims will be declined on corrosion-based cabinet and part failures.
12. Bard does not endorse, approve or certify any online sales of its products through auction websites, online retailers, liquidators or any other method of online sales direct to consumers. Bard will not honor the factory warranty of any Bard equipment purchased over the Internet.

## Your Responsibilities:

You are responsible for

1. Preventative maintenance of the product (such as cleaning coils and replacement of filters, nozzles and other consumable parts).
2. Ensuring that the instruction manual is followed for care and use of your product.
3. Ensuring that your product is installed by a competent, qualified contractor, following all local and national codes, and industry standards.

## What Bard Will Do About A Defect:

Bard will either repair or replace the defective part only. Replacement parts may be reconditioned parts. The warranty for the repaired or replaced part will last only for the remainder of the warranty period for the original part.

Defective parts must be supplied to a Bard distributor who will then submit a parts warranty claim form. Credits are issued to the Bard distributor.

Bard will not pay or be responsible for labor or defective/replacement part transportation costs or delays in repairing or failures to complete repairs caused by events beyond our reasonable control.

## What You Must Do

1. Tell your heating and air conditioning contractor as soon as you discover a problem and have the contractor make repairs.
2. Pay for all transportation, related service labor, diagnostic charges, refrigerant, refrigerant recovery and related items.

## Service

If your product requires service, you should contact the contractor who installed it or the contractor that has been providing the product's preventative maintenance and repair service. You may find the installing contractor's name on the product or in your Owner's packet. If you do not know who that is, you should contact a competent, qualified contractor to make the repairs. If in doubt, you should contact the nearest distributor that handles Bard products ([www.bardhvac.com](http://www.bardhvac.com)). Please note that contractors and distributors that handle Bard products are independent contractors and distributors, and therefore, are not under the direction of Bard Manufacturing Company, Inc.

## Only Warranty

There are no other express warranties. All implied warranties are limited in duration to the duration of the applicable written warranty made above.

Some states do not allow limitations on how long an implied warranty lasts, so the above limitation or exclusion may not apply to you.

## State of Florida Customers

The full length of the manufacturer's warranty of a HVAC system or component of the system is effective in the state of Florida on the date of installation if installed by a contractor licensed under part I of chapter 489. This form and the provided card are for warranty registration purposes. Failure to return the card or form does not diminish any warranty rights or decrease the warranty length.

**BARD MANUFACTURING CO., INC. — BRYAN, OHIO 43506**  
Dependable quality equipment . . . since 1914

Form No. 7960-420  
Issued: 08/13/24  
Supersedes: 07/13/23

**Duration Of Warranty** is limited to defects arising during the periods shown in the following table:

Model Number Series:	— Number of Years from Installation Date ① —			
	Compressor ④	Sealed System Components ② ④ ⑤	All Other Functional Parts ③	Heat Exchangers
<b>AIR CONDITIONERS</b> W12A, W18A, W24A, W30A, W36A, W42A, W48A, W60A, W72A, W090A, W120A, W150, W180A, W18L, W24L, W30L, W36L, W35A, W45A, W55A, Q36A, Q42A, Q48A, I30A, I36A, I42A, I48A, I60A, I36Z, I42Z, I48Z, I60Z	5	5	5	N/A
<b>AIR SOURCE HEAT PUMPS</b> W18H, W24H, W30H, W36H, W42H, W48H, W60H, C24H, C30H, C36H, C42H, C48H, C60H, T24H, T30H, T36H, T42H, T48H, T60H, T24S, T30S, T36S, T42S, T48S, T60S, Q24H, Q30H, Q36H, Q43H, Q48H, I30H, I36H, I42H, I48H, I60H, I36Z, I48Z, I60Z, W3VH, W5VH	5	5	5	N/A
<b>ENVIRONMENTAL CONTROL UNITS</b> W6RV, W6LV	5	5	1	N/A
<b>AGRICULTURAL UNITS</b> A36R and all HVAC equipment used in this application.	5	5	1	N/A
<b>EQUIPMENT SHELTER UNITS</b> MULTI-TEC, MEGA-TEC, FUSION-TEC, and all HVAC equipment used in this application.	5	5	1	N/A
<b>GEOHERMAL/WATER SOURCE HEAT PUMPS</b> QW2S, QW3S, QW4S, QW5S, QC50 (No Compressor)	5	5	5	N/A
<b>GAS/ELECTRIC WALL-MOUNT</b> W24G, W30G, W36G, W42G, W48G, W60G, WG2S, WG3S, WG4S, WG5S	5	5	5	10
<b>ACCESSORIES</b> Factory/Field Installed Bard Ventilation and Heater Packages, Bard branded Thermostats/ Temperature Controllers, UV-C LED Light Kits, LC6000, LV1000, MC4002, DC3003, TEC40, BG1000, PGD, PGDX, MC5300, MC5600.	N/A	N/A	5	N/A
Humidistats, C02 Controllers, add-on controller/thermostat cards and all other field-installed accessories not listed separately	N/A	N/A	1	N/A

- ① For equipment that does not have an online warranty registration, the warranty period starts when the product was shipped from the factory.
- ② Heat transfer coils (refrigerant to air coils for air source and coaxial coils for water source units) are covered for leaks for 5 years. Physical damage to air side coils resulting in leaks or insufficient airflow, or fin deterioration due to corrosive atmosphere (such as acids, halogenated hydrocarbons, agricultural or coastal environmental conditions) are not covered. Leaks in coaxial coils due to freezing of the coils are not covered. Copper coaxial coils for QW are not warranted for ground water/open loop installations.
- ③ Functional parts warranty is 1 year for all telecommunication, electric switch stations, pump stations, agricultural use, and similar applications. This also applies to all OTR (over the road) applications.
- ④ All OTR (over the road) applications that are moved from one location to another:  
Factory Warranty applies up to the point of initial start-up and test at all OEM manufacturing locations or subsequent outfitting facility. Once it goes into OTR service, the warranty expires immediately for compressor and sealed system components. This OTR exemption does not apply to relocatable classrooms, construction, or office trailers.
- ⑤ Factory-coated coils have a "5" year warranty in corrosive environments that are listed as approved.



**Internet Resources**

Recognized as a leader in the HVAC industry, Bard combines quality products and outstanding service with innovation and technological advances to deliver high-performance heating and cooling products around the world. Please visit [www.bardhvac.com](http://www.bardhvac.com) for additional information regarding warranty and product information.