

---

# INSTALLATION INSTRUCTIONS

---

## I-TEC<sup>®</sup> Series Packaged Heat Pump

Models:

I36Z1-A	I48Z1-A	I60Z1-A
I36Z1-B	I48Z1-B	I60Z1-B
I36Z1-C	I48Z1-C	I60Z1-C

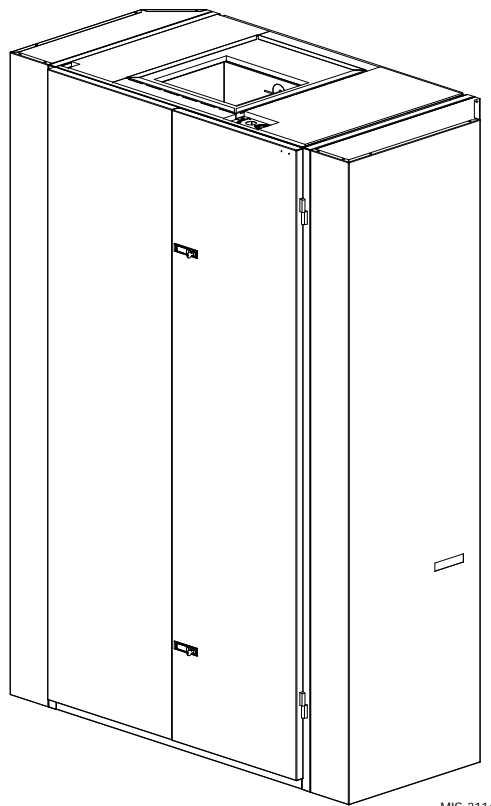

MS-3116



*Climate Control Solutions*

Bard Manufacturing Company, Inc.  
Bryan, Ohio 43506  
[www.bardhvac.com](http://www.bardhvac.com)

Manual: 2100-578P  
Supersedes: 2100-5780  
Date: 8-30-22

# CONTENTS

<b>Getting Other Information and Publications</b> .....	<b>3</b>
General .....	4
ANSI Z535.5 Definitions.....	4
<b>I-TEC Series General Information</b> .....	<b>5</b>
I-TEC Model Nomenclature .....	5
Shipping Damage .....	8
Unit Removal From Skid .....	8
Handling Unit After Removal from Skid .....	9
Required Steps After Final Placement .....	10
Minimum Installation Clearances .....	10
Securing Unit to Structure .....	10
Seismic Considerations .....	10
Rubber Mat .....	10
Duct Work.....	16
Filters .....	16
Condensate Drain .....	17
<b>Installation</b> .....	<b>20</b>
Mounting the Unit.....	20
Wiring – Main Wiring.....	20
Wiring – Low Voltage Wiring.....	20
Low Voltage Connections.....	21
General .....	21

## Figures

Figure 1	Unit Dimensions.....	7
	Center of Gravity.....	8
Figure 2A	Unit on Lift .....	9
Figure 2B	Unit Side .....	9
	Wall Mounting Bracket Location .....	10
	Bracket Wall Section View .....	11
	Wood Framed Installation .....	11
Figure 3	Compressor Shipping Bolts .....	12
Figure 4	Removal of Air Duct .....	12
Figure 5A	Ducted Application .....	13
Figure 5B	3" Riser Application .....	13
Figure 5C	6" Riser Application .....	14
Figure 5D	Required Clearances and Recommended Access.....	15
Figure 6	Supply Duct Connections.....	16
Figure 7	Filter Location .....	16
Figure 8	Drain Locations .....	17
Figure 9A	Unit Mounting .....	18
Figure 9B	Unit Mounting.....	19
Figure 10	Component Location .....	20
Figure 11	Basic Heat Pump w/No Vent Pkg. ....	22
Figure 12	Heat Pump w/CRV, without CO <sub>2</sub> Control ..	23
Figure 13	Heat Pump with CRV & CO <sub>2</sub> Control .....	24
Figure 14	Heat Pump Control Defrost Cycle.....	28
Figure 15	CRV Motor Speed/CFM Configuration .....	30
Figure 16	CRV Speed Change Terminal Access .....	31
Figure 17	Ventilation Airflow Diagram .....	32
Figure 18	Indoor Condensate Overflow Switch .....	35
Figure 19	Outdoor Condensate Sensor .....	35

<b>Start Up</b> .....	<b>25</b>
General .....	25
Topping Off System Charge .....	25
Safety Practices .....	25
Description of Standard Equipment.....	26
Important Installer Note.....	26
Phase Monitor .....	26
Three Phase Scroll Compressor Start Up Information ..	26
Service Hints .....	26
Sequence of Operation.....	27
Pressure Service Ports .....	27
Defrost Cycle .....	28
<b>I-TEC Commercial Room Ventilator System</b> .....	<b>29</b>
General Description .....	29
Control Wiring.....	29
Recommended Control Sequences .....	29
Setting the Ventilation CFM Levels.....	30
<b>Troubleshooting</b> .....	<b>33</b>
Solid State HP Control.....	33
Checking Temperature Sensor.....	34
Troubleshooting Condensate Overflow Systems .....	35
Troubleshooting ECM™ 142R Outdoor Fan Motors .....	36
Troubleshooting ECM™ Indoor Blower Motors .....	38
Fan Blade Setting Dimensions .....	41
Refrigerant Charge.....	41

Figure 20	Outdoor Condensate Control.....	35
Figure 21	Control Disassembly.....	39
Figure 22	Winding Test .....	39
Figure 23	Drip Loop.....	39
Figure 24	Control Connector Motor Half .....	40
Figure 25	Fan Blade Position.....	41

## Tables

Table 1	Factory Built-In Electric Heat Table .....	5
Table 1A	Indoor Blower Performance.....	5
Table 2	Electrical Specifications .....	6
	Center of Gravity Table .....	8
Table 3	Operating Voltage Range.....	21
Table 4	Wall Thermostats .....	21
Table 5	Troubleshooting .....	33
Table 6	Temperature (F) vs. Resistance (R) of Temperature Sensor .....	34
Table 7	Troubleshooting ECM™ 142R Outdoor Fan Motors.....	37
Table 8	Cooling Mode .....	37
Table 9	Heat Pump Mode.....	37
	Troubleshooting ECM™ Indoor Blower Motors .....	40
	Power Connector.....	40
Table 10A	Full Load Cooling Pressure/Temperature .....	42
Table 10B	Full Load Heating Pressure/Temperature.....	42
Table 11A	Part Load Cooling Pressure/Temperature .....	42
Table 11B	Part Load Heating Pressure/Temperature .....	42

---

## GETTING OTHER INFORMATION AND PUBLICATIONS

These publications can help when installing the air conditioner or heat pump. They can usually be found at the local library or purchase them directly from the publisher. Be sure to consult current edition of each standard.

National Electrical Code ..... ANSI/NFPA 70  
Standard for the Installation of Air Conditioning  
and Ventilating Systems

..... ANSI/NFPA 90A

Standard for Warm Air Heating and  
Air Conditioning Systems

..... ANSI/NFPA 90B

Load Calculation for Winter and Summer  
Air Conditioning ..... ACCA Manual J or Manual N

Low Pressure, Low Velocity Duct System Design

Winter and Summer Air Conditioning

..... ACCA Manual D or Manual Q

For more information, contact these publishers:

**ACCA**     **Air Conditioning Contractors of America**  
1712 New Hampshire Avenue  
Washington, DC 20009  
Telephone: (202) 483-9370  
Fax: (202) 234-4721

**ANSI**     **American National Standards Institute**  
11 West Street, 13th Floor  
New York, NY 10036  
Telephone: (212) 642-4900  
Fax: (212) 302-1286

**ASHRAE**   **American Society of Heating, Refrigeration,  
and Air Conditioning Engineers, Inc.**  
1791 Tullie Circle, N.E.  
Atlanta, GA 30329-2305  
Telephone: (404) 636-8400  
Fax: (404) 321-5478

**NFPA**     **National Fire Protection Association**  
Batterymarch Park  
P.O. Box 9101  
Quincy, MA 02269-9901  
Telephone: (800) 344-3555  
Fax: (617) 984-7057

## General

The equipment covered in this manual is to be installed by trained, experienced service and installation technicians.

*The I-TEC must be installed with the Bard manufactured IWS wall sleeve and ILG louver grille accessories. These are sold as separate accessories. Any substitutions will void the manufacturer's warranty.*

The unit is designed for use with or without ductwork. For use without ductwork, Plenum Box IPBDFZ18-color (18" height) or IPBDFZ12-color (12" height) is recommended.

These instructions explain the recommended method to install the air cooled self-contained unit and the electrical connections to it.

These instructions and any instructions packaged with any separate equipment required to make up the entire heating and air conditioning system should be carefully read before beginning the installation. Note particularly "Start Procedure" and any tags and/or labels attached to the equipment.

While these instructions are intended as a general recommended guide, they do not supersede any national and/or local codes in any way. Authorities having jurisdiction should be consulted before the installation is made. See page 3 for information on codes and standards.

Size of unit for a proposed installation should be based on heat loss or heat gain calculation made according to methods of Air Conditioning Contractors of America (ACCA). The air duct should be installed in accordance with the Standards of the National Fire Protection Systems of Other Than Residence Type, NFPA No. 90A and Residence Type Warm Air Heating and Air Conditioning Systems, NFPA No. 90B. Where local regulations are at a variance with instructions, installer should adhere to local codes.

## ANSI Z535.5 Definitions:

- **DANGER:** Indicate[s] a hazardous situation which, if not avoided, will result in death or serious injury. The signal word "DANGER" is to be limited to the most extreme situations. DANGER [signs] should not be used for property damage hazards unless personal injury risk appropriate to these levels is also involved.
- **WARNING:** Indicate[s] a hazardous situation which, if not avoided, could result in death or serious injury. WARNING [signs] should not be used for property damage hazards unless personal injury risk appropriate to this level is also involved.
- **CAUTION:** Indicate[s] a hazardous situation which, if not avoided, could result in minor or moderate injury. CAUTION [signs] without a safety alert symbol may be used to alert against unsafe practices that can result in property damage only.
- **NOTICE:** [this header is] preferred to address practices not related to personal injury. The safety alert symbol shall not be used with this signal word. As an alternative to "NOTICE" the word "CAUTION" without the safety alert symbol may be used to indicate a message not related to personal injury.



# I-TEC Series General Information

## I-TEC Model Nomenclature Z-Version (CA) 2-Stage Air Source Heat Pumps

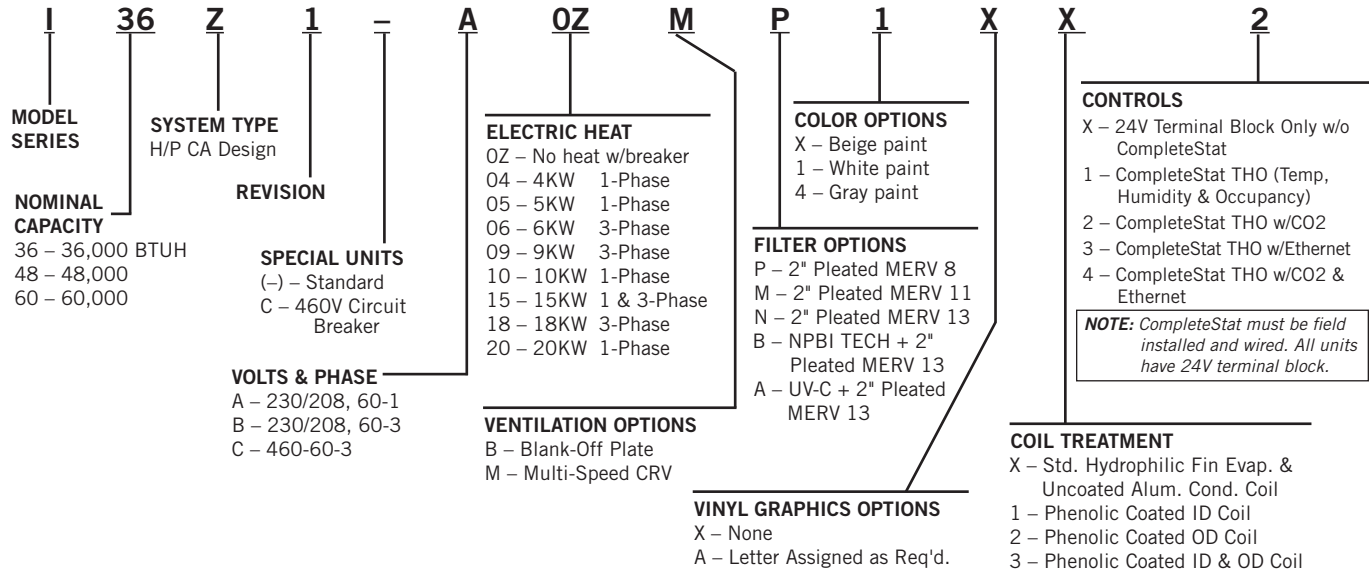

**TABLE 1**  
Factory Built-In Electric Heat Table

Models	I36Z1-A		I36Z1-B		I36Z1-C	I48Z1-A		I48Z1-B I60Z1-B		I48Z1-C I60Z1-C	I60Z1-A	
	240V-1 BTUH	208V-1 BTUH	240V-3 BTUH	208V-3 BTUH	460V-3 BTUH	240V-1 BTUH	208V-1 BTUH	240V-3 BTUH	208V-3 BTUH	460V-3 BTUH	240V-1 BTUH	208V-1 BTUH
4.0						13,652	10,239					
5.0	17,065	12,799				17,065	12,799				17,065	12,799
6.0			20,478	15,359	20,478			20,478	15,359	20,478		
9.0			30,717	23,038	30,717			30,717	23,038	30,717		
10.0	34,130	25,598				34,130	25,598				34,130	25,598
15.0	51,195	38,396	51,195	38,396	51,195	51,195	38,396	51,195	38,396	51,195	51,195	38,396
18.0								61,434	46,076	61,434		
20.0						68,260	51,195				68,260	51,195

**TABLE 1A**  
Indoor Blower Performance ①

Model	Rated ESP	Max. ESP	② Continuous CFM	Rated 2nd Stage CFM	Rated 1st Stage CFM	③ 4 - 10KW CFM	④ 15 - 20KW CFM
I36Z1	.15	0.50	600	1150	850	700	1050
I48Z1	.20	0.50	725	1400	1050	700	1400
I60Z1	.20	0.50	850	1600	1100	700	1400

① Motor will deliver consistent CFM through voltage supply range with no deterioration.  
 ② Continuous fan CFM is the total air being circulated during continuous fan mode.  
 ③ Will operate at rated Full Load Airflow when operating with heat pump.  
 ④ Will occur automatically with a call for "W3" or "Emergency Heat" signal from the thermostat (heat pump operation is terminated at this condition).

**TABLE 2  
Electrical Specifications**

MODEL	Rated Volts, Hertz & Phase	Single Circuit					Multiple Circuit							
		No. Field Power Circuits	Minimum Circuit Ampacity	Maximum External Fuse or Ckt. Brkr.	Field Power Wire Size	Ground Wire	Minimum Circuit Ampacity		Maximum External Fuse or Ckt. Breaker		Field Power Wire Size		Ground Wire Size	
							Ckt. A	Ckt. B	Ckt. A	Ckt. B	Ckt. A	Ckt. B	Ckt. A	Ckt. B
I36Z1-A0Z A05 A10 Ⓞ A15	230/208-1	1 1 1 or 2 1 or 2	26 52 78 84	40 60 80 90	8 6 4 4	10 10 8 8	26 26	52 52	40 40	60 60	8 8	6 6	10 10	10 10
I36Z1-B0Z B06 B09 Ⓞ B15	230/208-3	1 1 1 1	22 40 49 51	30 45 50 60	10 8 8 6	10 10 10 10								
I36Z1-C0Z C06 C09 Ⓞ C15	460-3	1 1 1 1	11 20 24 28	15 20 25 30	14 12 10 10	14 12 10 10								
I48Z1-A0Z A04 A05 A10 Ⓞ A15 Ⓞ A20	230/208-1	1 1 1 or 2 1 or 2 1 or 2 1 or 2	34 54 59 85 85 110	50 60 70 90 90 110	8 6 6 3 3 2	10 10 8 8 8 6	35 35 35 59	26 52 52 52	45 45 45 60	30 60 60 60	8 8 8 6	10 6 6 6	10 10 10 10	10 10 10 10
I48Z1-B0Z B06 B09 Ⓞ B15 Ⓞ B18	230/208-3	1 1 1 1 1	26 44 53 53 53	35 50 60 60 60	8 8 6 6 6	10 10 10 10 10								
I48Z1-C0Z C06 C09 Ⓞ C15 Ⓞ C18	230/208-1	1 1 1 1 1	15 25 29 29 29	20 30 30 30 30	12 10 10 10 10	12 10 10 10 10								
I60Z1-A0Z A05 A10 Ⓞ A15 Ⓞ A20	230/208-1	1 1 or 2 1 or 2 1 or 2 1 or 2	44 70 96 96 112	60 80 100 100 120	8 4 3 3 2	10 8 8 8 6	44 44 44 60	26 52 52 52	60 60 60 60	30 60 60 60	8 8 8 6	10 6 6 6	10 10 10 10	10 10 10 10
I60Z1-B0Z B06 B09 Ⓞ B15 Ⓞ B18	230/208-3	1 1 1 1 2	31 49 58 58 58	45 60 60 60 60	8 8 6 6 6	10 10 10 10 10	31	54	45	60	8	6	10	10
I60Z1-C0Z C06 C09 Ⓞ C15 Ⓞ C18	460-3	1 1 1 1 1	15 25 29 29 29	20 30 30 30 30	12 10 10 10 10	12 10 10 10 10								

These "Minimum Circuit Ampacity" values are to be used for sizing the field power conductors. Refer to the National Electric Code (latest revision), Article 310 for power conductor sizing.

**CAUTION:** When more than one field power conductor circuit is run through one conduit, the conductors must be derated. Pay special attention to Note 8 of Table 310 regarding Ampacity Adjustment Factors when more than three (3) current carrying conductors are in a raceway.

Maximum size of the time delay fuse or circuit breaker for protection of field wiring conductors.

Based on 75°C copper wire. All wiring must conform to the National Electrical Code and all local codes.

Maximum KW that can operate with the heat pump is 10KW for 1-Phase and 9KW for 3-Phase.

Ⓞ Represents Electric Heat only. Electric Control Circuit will lock-out Heat Pump Operation.

**FIGURE 1 – Unit Dimensions**

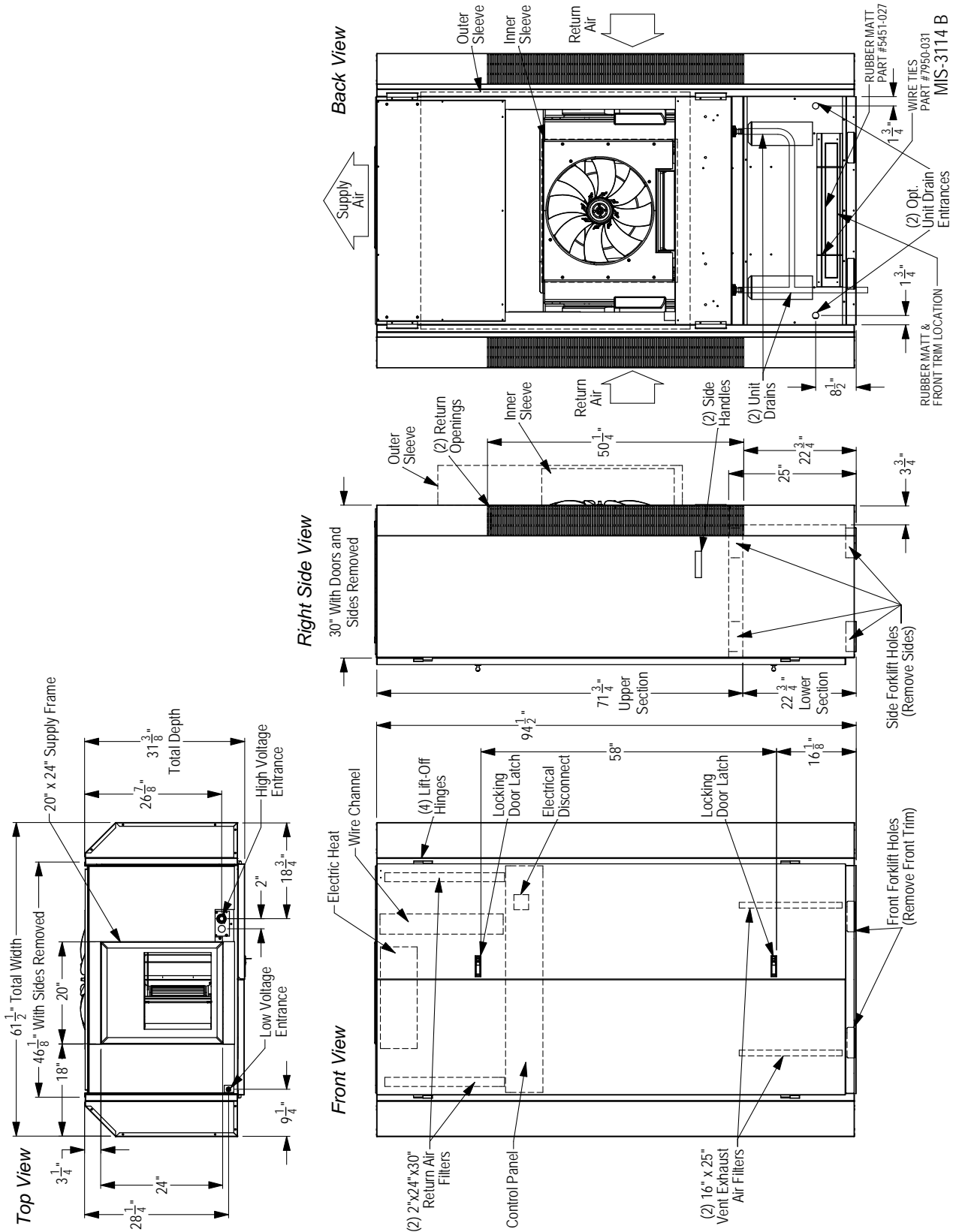

## Center of Gravity

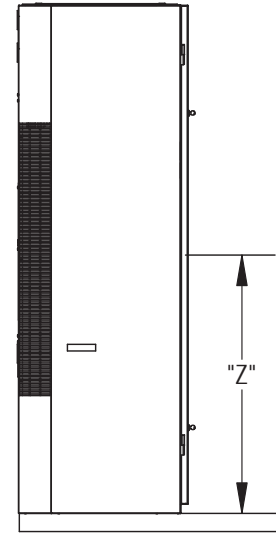
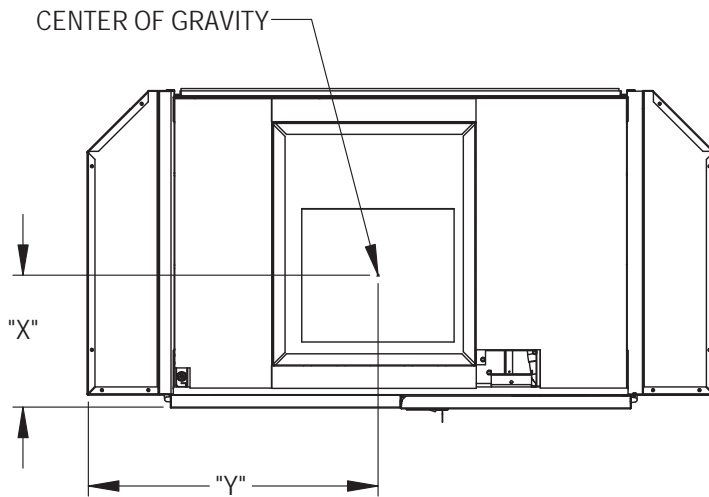

MIS-3268

Unit Tested	Front of Unit Door to center	Left side to center	Floor to Center Crv & erv	Floor to Center no vent
	"X" Dimension	"Y" Dimension	"Z" Dimension	"Z" Dimension
I36Z1-A, B	13½"	31"	43½"	47"
I36Z1-C	13½"	31½"	43½"	47"
I48Z1-A, B	13½"	31"	43½"	47"
I48Z1-C	13½"	31½"	43½"	47"
I60Z1-A, B	13½"	31"	43½"	47"
I60Z1-C	13½"	31½"	43½"	47"

### Shipping Damage

Upon receipt of equipment, the unit should be checked for external signs of shipping damage. The skid must remain attached until the unit is ready for installation. If damage is found, the receiving party must contact the last carrier immediately, preferably in writing, requesting inspection by the carrier's agent.

### Unit Removal from Skid

WARNING

*This unit is heavy and requires more than one person to handle during installation and removal from the skid. Extreme caution must be taken to prevent injury to personnel and damage to the unit. Use appropriate safety equipment, including gloves when handling. Failure to do so may result in serious injury.*

A forklift or a lift rated for the load (Figure 2A) is required to lift the unit off from the skid. This unit is top heavy and should never be tipped while moving it.

The I-TEC is designed to be lifted off the skid from the front or rear of the unit without having to remove any doors or side panels. See Figure 1 for fork openings. The shipping brackets on front and rear of the unit must be removed and discarded. The unit can now be lifted straight up and the skid can be slid out from underneath.

CAUTION

*Tip unit from left side only.  
Failure to do so may result in injury due to unit top-heaviness or compressor damage!*

## Handling Unit after Removal from Skid

If a wide and tall opening exists, the I-TEC can be moved as a complete assembled unit. If not, use the following directions for disassembly to allow it to pass through a 36" wide door.

1. Depress and release both top and bottom door latches and open doors.
2. Remove doors by lifting straight up and off from the hinge pins.
3. Remove cabinet sides by first removing the four (4) sheet metal screws from the front (leading edge) of the side panel. The panel will not fall off. Swing the panel away from the chassis 20-30° and then pull forward from the two tabs supporting the rear edge. At this point, the unit can be tipped on its left side enough to get dolly carts under it. Use dolly carts to move unit into installation area. Use care not to damage vent wire harness. This method is not suggested due to unit weight and if a forklift or unit lift is available, continue with the following steps for separation of top section and bottom base.
4. On each side of the unit is a tie plate that secures the top and bottom sections with four (4) cap bolts. Using a ½" wrench or socket, remove these screws from both plates and set aside.
5. If the unit is equipped with a CRV, unplug the wire harness on the left-hand side of the control box.
6. **A forklift or a lift rated for the load is required to lift the top section off from the bottom base. Do not attempt to do this manually! Failure to do so could result in the unit tipping over and causing bodily injury and/or damage to the unit.**
7. The top section can be forked from either the right-hand or left-hand side. See Figure 1 for fork openings.
8. Carefully lift the top section straight up avoiding tipping.
9. Move the top section through the doorway and place on flat surface free of debris.
10. The bottom base can now be moved through the doorway the same way.
11. Reassemble the unit by reversing this procedure.

**FIGURE 2A**  
Unit on Lift



**FIGURE 2B**  
Unit Side

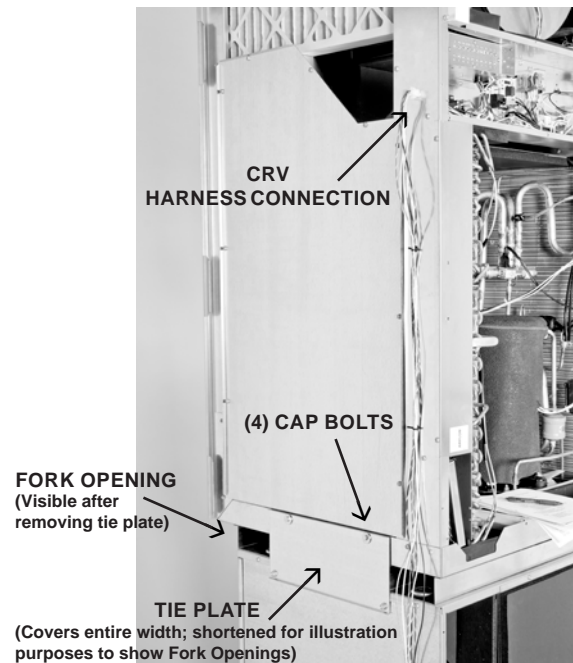

## Required Steps after Final Placement

The compressor is secured to the base with two (2) bolts for shipping. Although the unit will perform as designed with the shipping bolts in place, there may be noticeable additional noise and vibration noted. To obtain the lowest noise and vibration levels, remove the shipping bolts after the unit is in its final operating location. To gain access to the compressor, the compressor access panel must be removed (Figure 7). Once this panel is removed, the CRV air duct must be removed (see Figure 4).

The air duct is removed by pulling it straight out; there are no screws securing it in place. Both the top and bottom slide at the same time (*pull hard*). Once removed, the compressor is visible as well as the tags on the shipping bolts (see Figure 3).

After the compressor shipping bolts have been removed, the CRV air duct can be slid back in place and the compressor access panel attached.

## Minimum Installation Clearances

The minimum installation height to the bottom of the roof or fixed ceiling for ducted applications is 9' 7". This provides enough clearance to install the duct work. See Figure 5A.

The IWS Series wall sleeve has a built-in vertical adjustment to fit window sill heights from 31-34". If additional height is required, two riser platform accessories are available. The IRZ3 increases the unit height by 3" (Figure 5B) and the IRZ6 by 6" (Figure 5C).

Several construction options are available for unit installation of the IZ Series. Serviceability and filter access must be considered before installing. See Figure 5D for required clearances and recommended service access dimensions.

## Securing Unit to Structure

Shipped with the I-TEC unit is a wall-mounting bracket (screwed to shipping skid on backside of unit). This bracket can be utilized to secure the top portion of the unit to the wall using the appropriate field-supplied hardware based upon the material being fastened to. (*There are several offset holes, sized to accept up to a 1/4" diameter fastener, that will easily allow studs to be hit on a framed wall.*) See **Bracket Wall Section View** for locating this top wall bracket which will need to be applied after the unit is located in the final position.

Additional/optional mounting holes for up to a 3/8" diameter fastener are also available in the backside and base of the unit. These can be accessed by:

- Removing the air filters (uppermost set)
- Removing the compressor section service door (lower set)
- Removing vent door and vent partitions (base set)

Refer to **Wood Framed Installation** for additional framing required to secure unit to wall.

**The additional/optional mounting holes will require a long extension to drive the fasteners.**

## Seismic Considerations

The I-TEC product features several locations for product securement but all site conditions are different. Consult with a licensed Seismic Engineer to advise of particular needs when attaching the I-TEC unit to the structure.

## Rubber Mat

Unit rests on rubber mat placed under base rails during installation. Place mat on floor flush with wall and centered over wall opening.

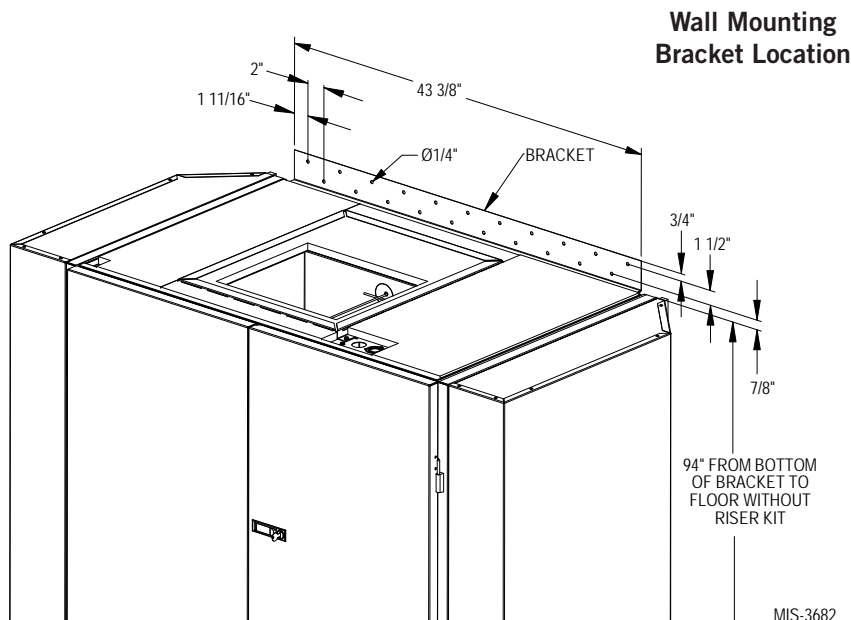

### Bracket Wall Section View

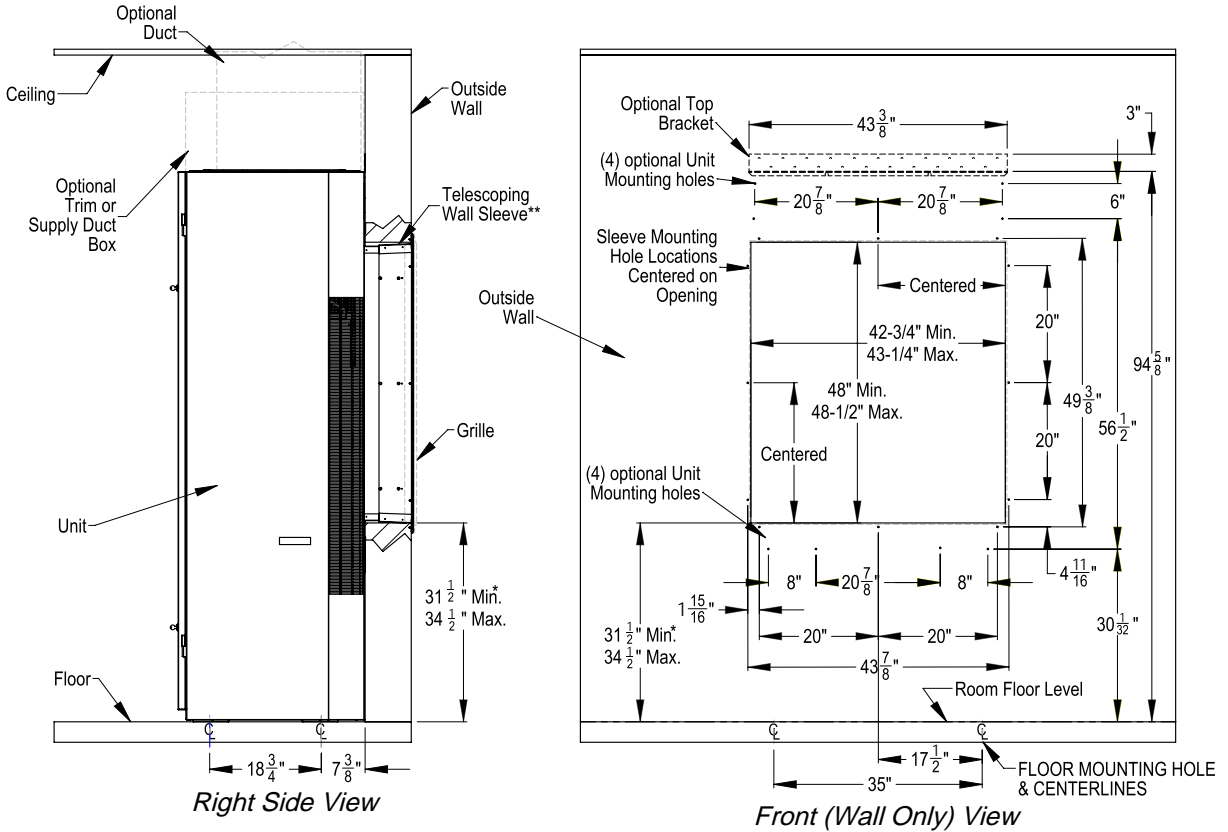

\* Higher Sill Heights Achievable With Base Kit.  
 \*\* Separate telescoping sleeves available for different wall thicknesses.

MIS-3196 B

### Wood Framed Installation (for Wall Attachment)

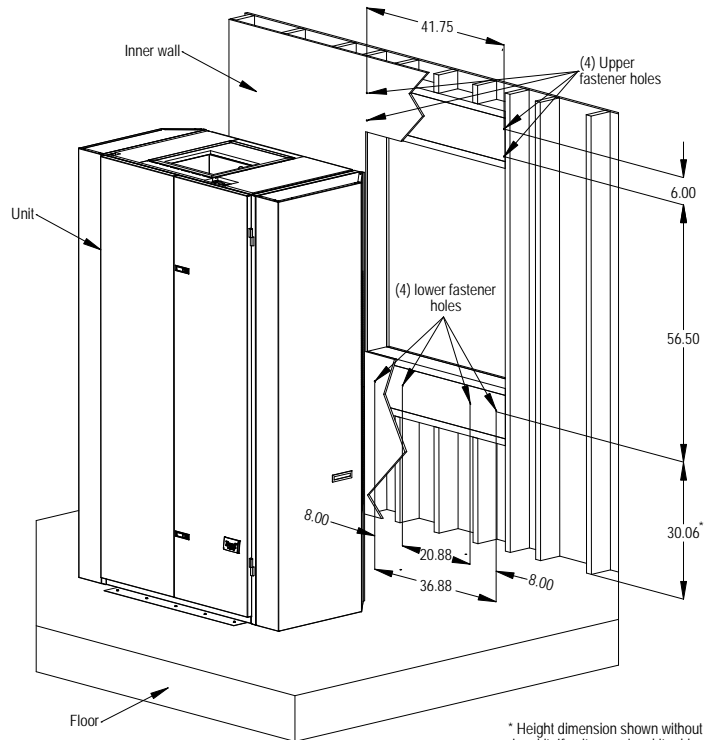

\* Height dimension shown without riser kit. If unit uses riser kit add appropriate dimension to height.

MIS-3197 A

**FIGURE 3**  
**Compressor Shipping Bolts**

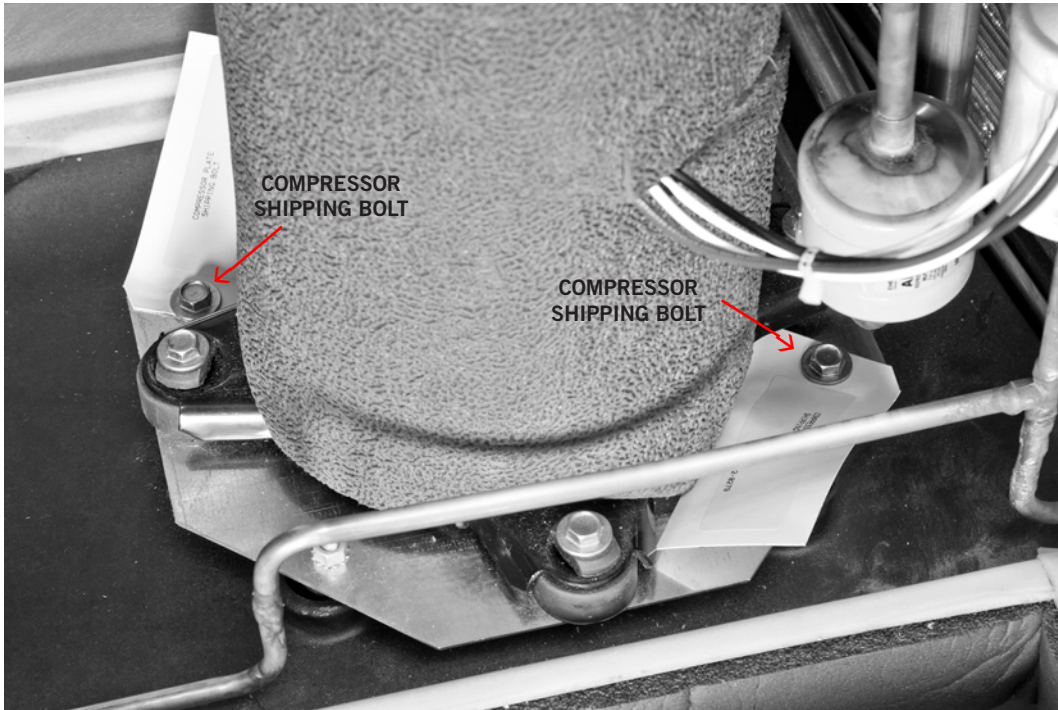
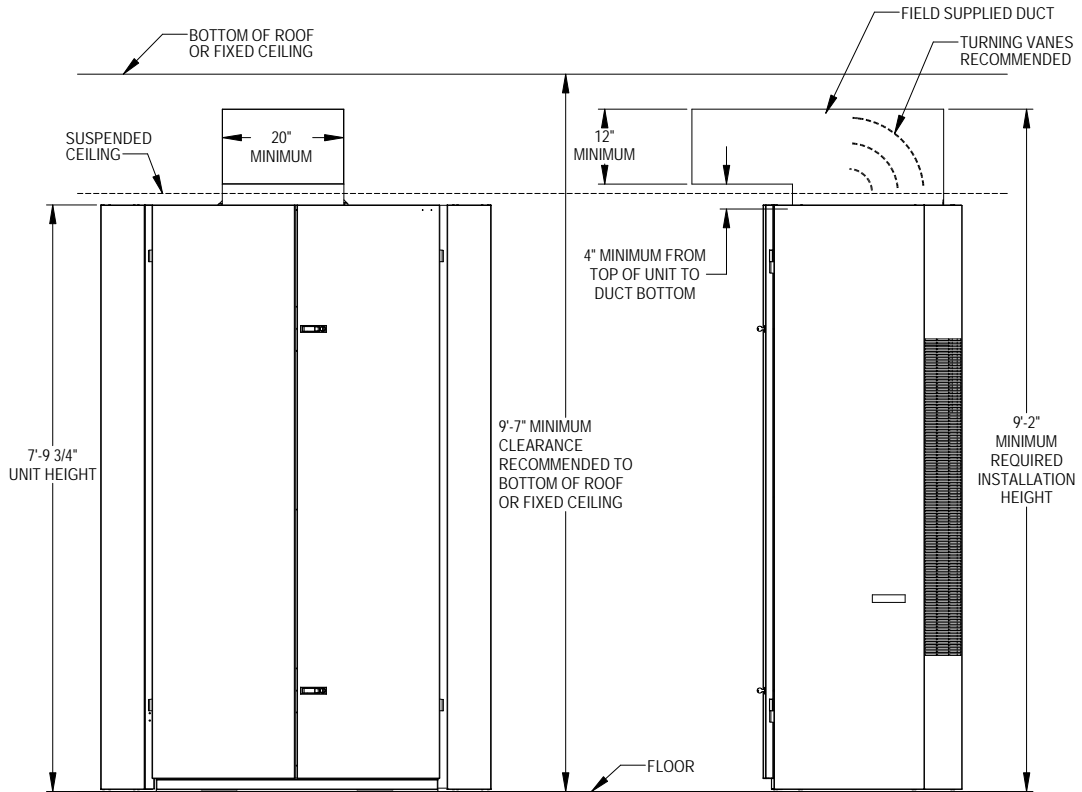

**FIGURE 4**  
**Removal of Air Duct**

CRV  
AIR DUCT

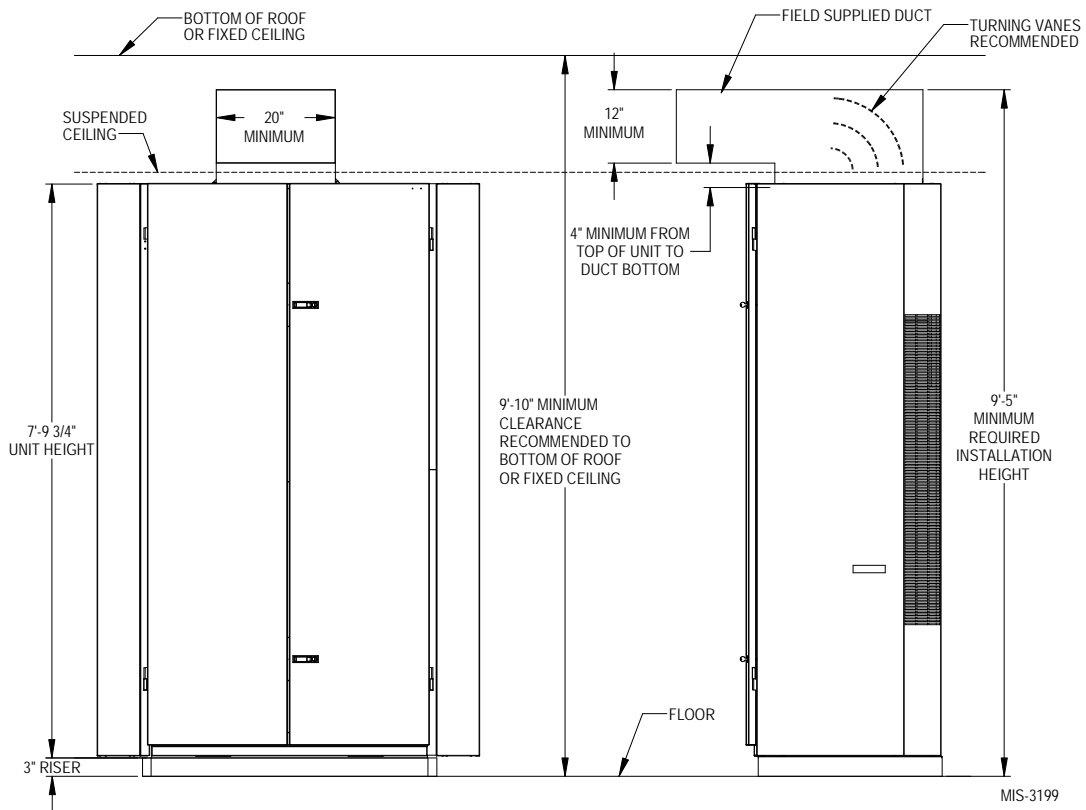

**FIGURE 5A**  
**Ducted Application – Basic Unit**



MIS-3198

**FIGURE 5B**  
**3\"/>**



MIS-3199

**FIGURE 5C**  
**6" Riser Application**

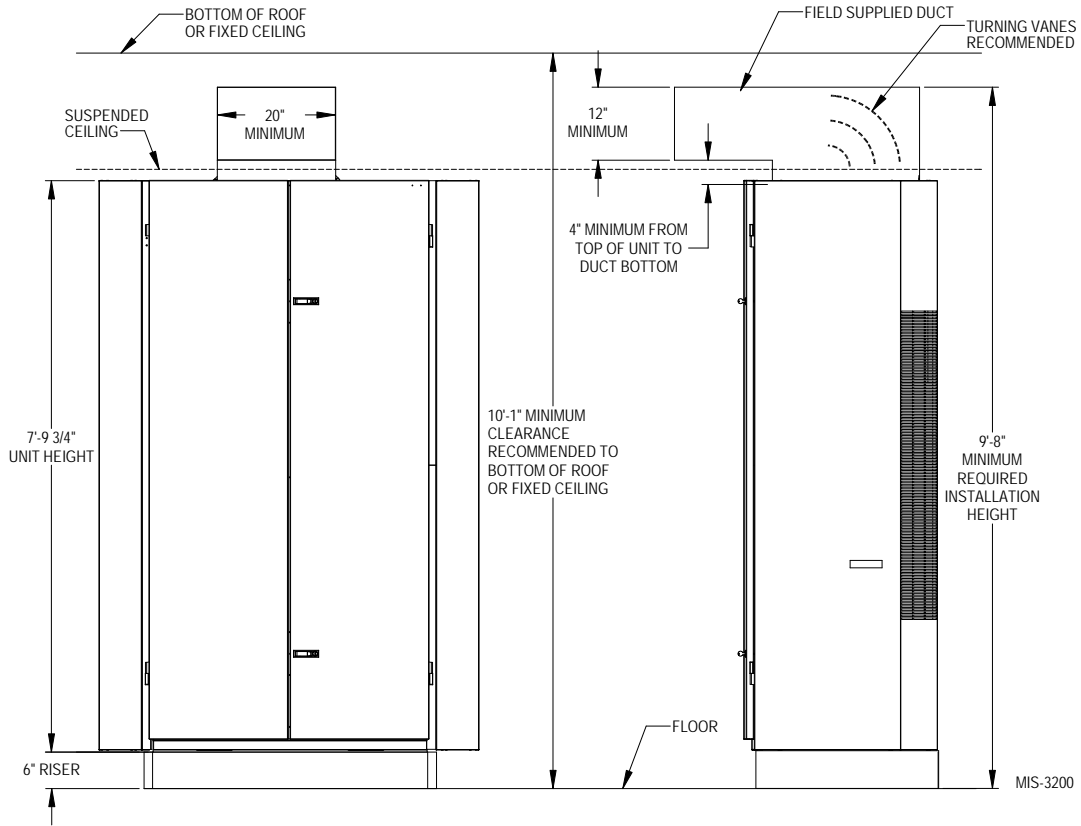

**FIGURE 5D**  
**Required Clearances and Recommended Access**

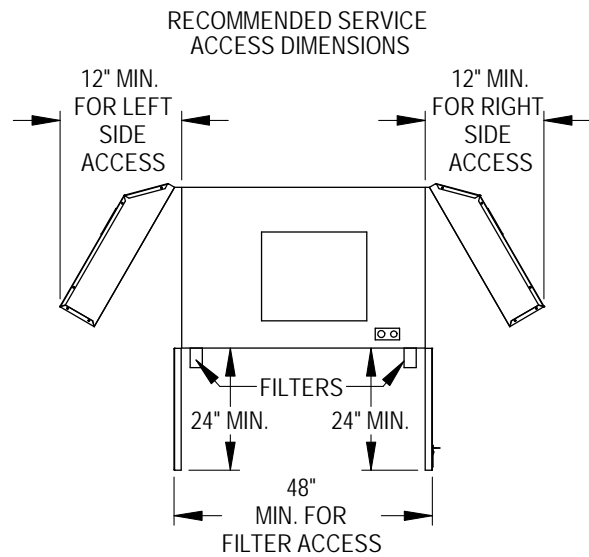
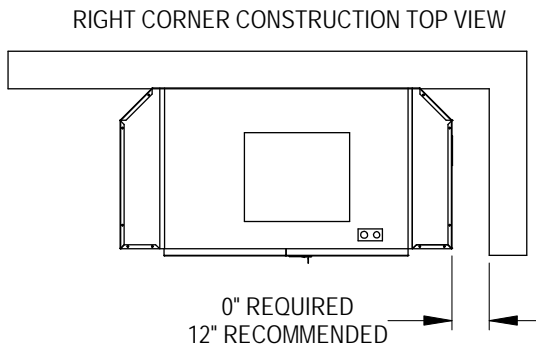
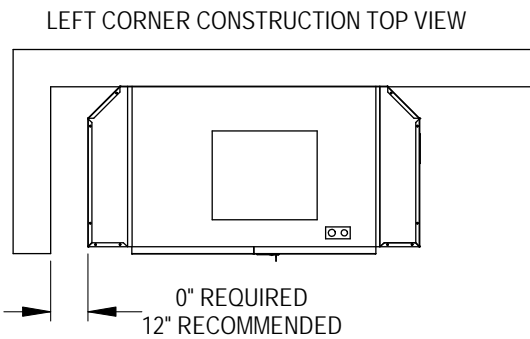
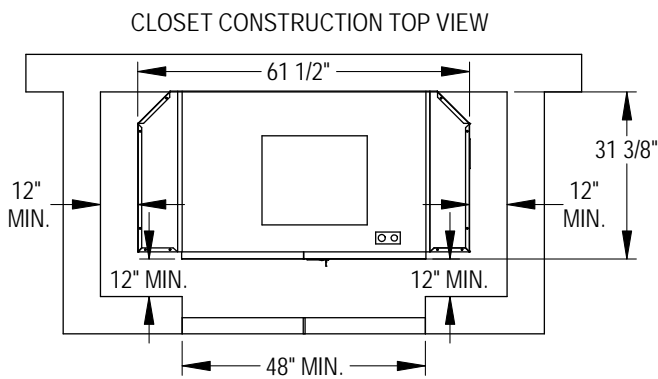
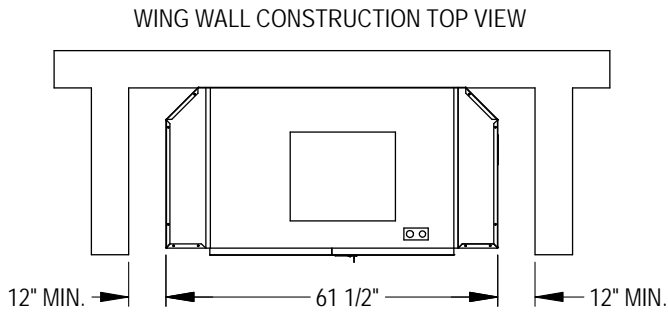

**IMPORTANT**  
 Unit can be located in corner with 0" clearance as long as other side is unobstructed

MIS-3230

## Duct Work

Any heat pump is more critical of proper operating charge and an adequate duct system than a straight air conditioning unit. All duct work must be properly sized for the design airflow requirement of the equipment. Air Conditioning Contractors of America (ACCA) is an excellent guide to proper sizing. All duct work or portions thereof not in the conditioned space should be properly insulated in order to both conserve energy and prevent condensation or moisture damage. When duct runs through unheated spaces, it should be insulated with a minimum of 1" of insulation. Use insulation with a vapor barrier on the outside of the insulation. Flexible joints should be used to connect the duct work to the equipment in order to keep the noise transmission to a minimum.

The I-TEC series heat pump has provision to attach a supply air duct to the top of the unit. Duct connection size is 20" x 24". The flanges are shipped flat and must be bent upward using sheet metal flanging pliers. The duct work is field supplied. See Figure 6 for suggested attachment method.

**Make sure to seal the slots in the bend-up flange at the time of securing the ductwork to the flange. This can be accomplished with either foil tape or caulk. Failing to do so may cause air leakage/whistling of air.**

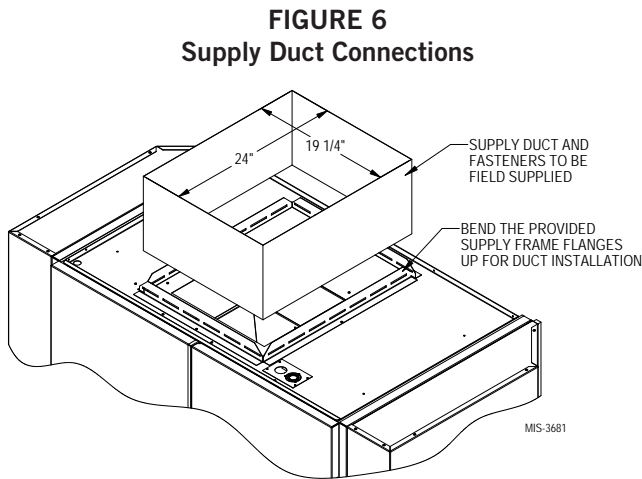

**NOTE:** Unit cabinet, supply air duct and duct free plenum are approved for 0" clearance to combustible material.

The I-TEC series heat pumps are designed for use with free return (non-ducted) and either duct free with the use of IPBDFZ Series Plenum Box (18" or 12") or a duct supply air system.

The IPBDZ Plenum Box mounts on top of the unit and has both vertically and horizontally adjustable louvers on the front discharge grille.

When used with a ducted supply, a cabinet extension may be used to conceal the ductwork above the unit to

the ceiling. The ICX28 extends 28" above the unit for a total height of 10'-2" or can be trimmed to any height.

The unit is equipped with a variable speed indoor blower motor which increases in speed with an increase in duct static pressure. The unit will therefore deliver proper rated airflow up to the maximum ESP shown in Table 1A. However, for quiet operation of the air system, the duct static should be kept as low as practical, within the guidelines of good duct design.

## Filters

Two 2" throw away filters (24 x 30) and two 1" throw away filters (16 x 25) are supplied with each unit. The 2" filters slide into brackets on both sides for the return air openings. If a CRV vent option is used, there are two additional 1" throw away filters included with that option. See Figure 7 for specific locations. The filters are serviced from the inside of the building by opening the cabinet doors and do not require any tools to access.

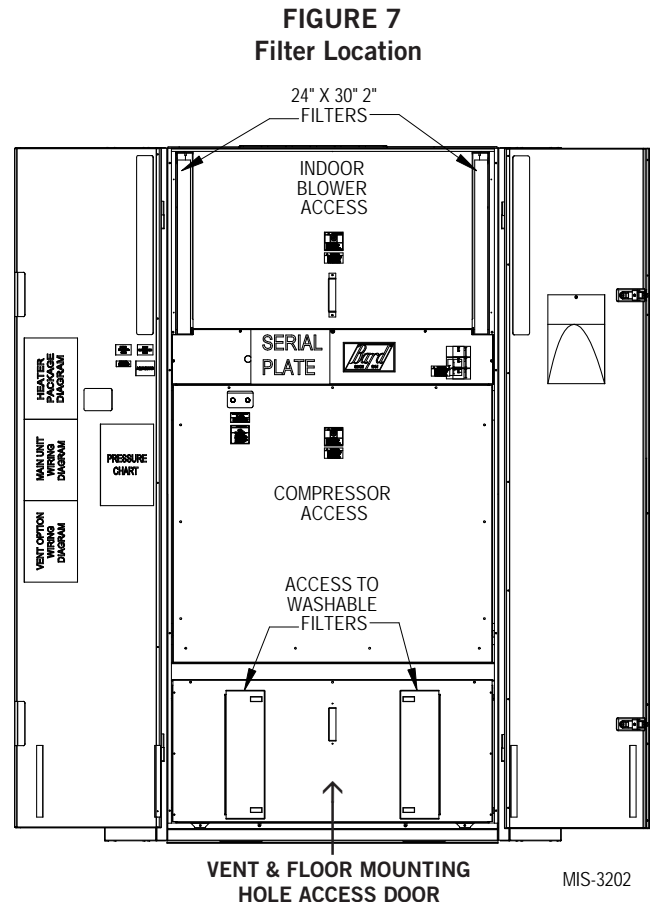

## Condensate Drain

There are two condensate drain connections from the condenser drain pan (compressor area). These are visible from the rear of the unit. Factory-installed tubing connects the two drains at a tee connection and then a single drain hose with a barbed hose connector carries the condensate to the draining option chosen. Enough tubing is provided to reach all drain options and can be cut down in length.

The unit is shipped from the factory with the drain line on the left-hand side when looking at the rear of the unit. The tubing can be removed from the drain connections and flipped for a right-hand drain (see Figure 8).

The drain can be routed directly through the floor or through the wall. There are also two optional drain locations in the lower rear back panel (see Figure 8).

The I-TEC design does not require a trap in the condensate disposal tubing. Check local codes to see if a "P" trap is required.

For a stand pipe floor drain or through the wall, there is adequate hose length to reach needed location behind the unit. The lower rear portion of the cabinet is recessed approximately 4" allowing room for a "P" trap (if required) to be installed with the cabinet flush with the wall. Keep in mind, the drain line must be able to be removed from the unit if necessary to remove the unit from the wall.

Access plates are located on the rear of the unit for servicing the drain trap (see Figure 8). ***If the drain line is to be routed through an unconditioned space, it must be protected from freezing.***

The condensate drain line can also be routed back into the unit through either the right-hand or left-hand optional drain locations on the rear of the unit. The hole is covered by insulation on the inside of the unit and will have to be cut away. Located inside the unit, about 12" in from the front on both the left and right side are drain holes in the bottom of the base. These holes are covered with insulation and are not visible from inside vent option area. They are located very close to the side panels and can be found by pressing down on the insulation or looking at back of vent option area (see Figure 8). Cut insulation away to expose the hole. A drain trap can now be installed inside of the cabinet, and the drain hose routed directly through the floor.

Once the I-TEC is installed, the rear drains exiting the condenser section can be easily serviced with removal of the pre-painted metal sides (lift-off doors, remove four [4] screws to remove side).

If side access is not available, the drain lines and trap can be serviced by removing either one of the drain access panels on the rear of the unit (in the ventilation package area (see Figure 8).

***After drain installation is complete, drain area must be insulated for sound purposes with 45" x 24¾" x 6" piece of insulation (see Figure 8).***

### With No Vent Option

To remove the drain access panels in the rear of this section, simply remove the front door/cover from the box. Rear drain access panels are now visible on both right-hand and left-hand sides in rear of box.

### With Commercial Room Ventilator

1. Open hinged front doors.
2. Disconnect unit power to eliminate shock hazard.
3. Remove front cover/door of CRV vent package. (Can leave filter access panels in place.)
4. Unplug wires coming in on left side from upper unit section.
5. Unplug two (2) wire harness from front (intake) blower.
6. Remove two (2) screws securing front (intake) blower and slide blower out of unit.
7. Remove four (4) screws that retain the partition behind/beneath intake blower removed in Step 6.
8. Rear drain access panels are now visible on both right-hand and left-hand sides in rear of box.

**FIGURE 8**  
**Drain Locations**

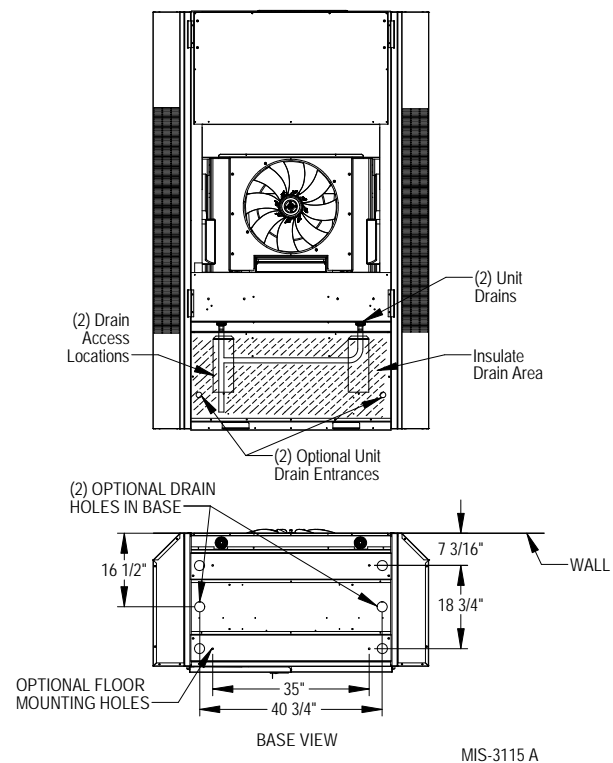

**FIGURE 9A**  
**Unit Mounting**

Use (12) Field Supplied Concrete or Wood Screws to Secure Outer Sleeve to Structure.

**IMPORTANT!**  
Apply liberal amount of caulk to back of flange before installing.

REF. A

Use (6) 3/4" Long Self Tapping Screws to Attach Inner Sleeve to Outer Sleeve

**IMPORTANT!**  
Apply Caulk bead to entire perimeter seam between inner and outer sleeve.

REF. B

Use (12) 3/4" Long Self Tapping Screws to Attach Inner Sleeve to Unit Back

**IMPORTANT!**  
Use care when inserting screws to not damage gasketing material. Doing so may compromise water seal between unit and sleeve.

Pull Inner Frame Out Until Flush With Grille Mounting Angle

REF. E  
Use (4) 1-1/2" Long Screws to Attach Louver Grille to Outer Sleeve.

REF. C  
Use (6) 3/4" Long Screws to Attach Exhaust Sleeve to Unit Fan Shroud

REF. D

Use (4) 1/2" Long Screws to Attach frame to Exhaust Sleeve

(18) 5/16" - 3/4" SELF TAPPING	REF. A AND B	
(6) 5/16" - 3/4" NON-TAPPING	REF. C	
(4) 5/16" - 1/2" NON-TAPPING	REF. D	
(4) 1-1/2" LONG SCREWS	REF. E	

MIS-3014 A

**FIGURE 9B**  
**Unit Mounting**

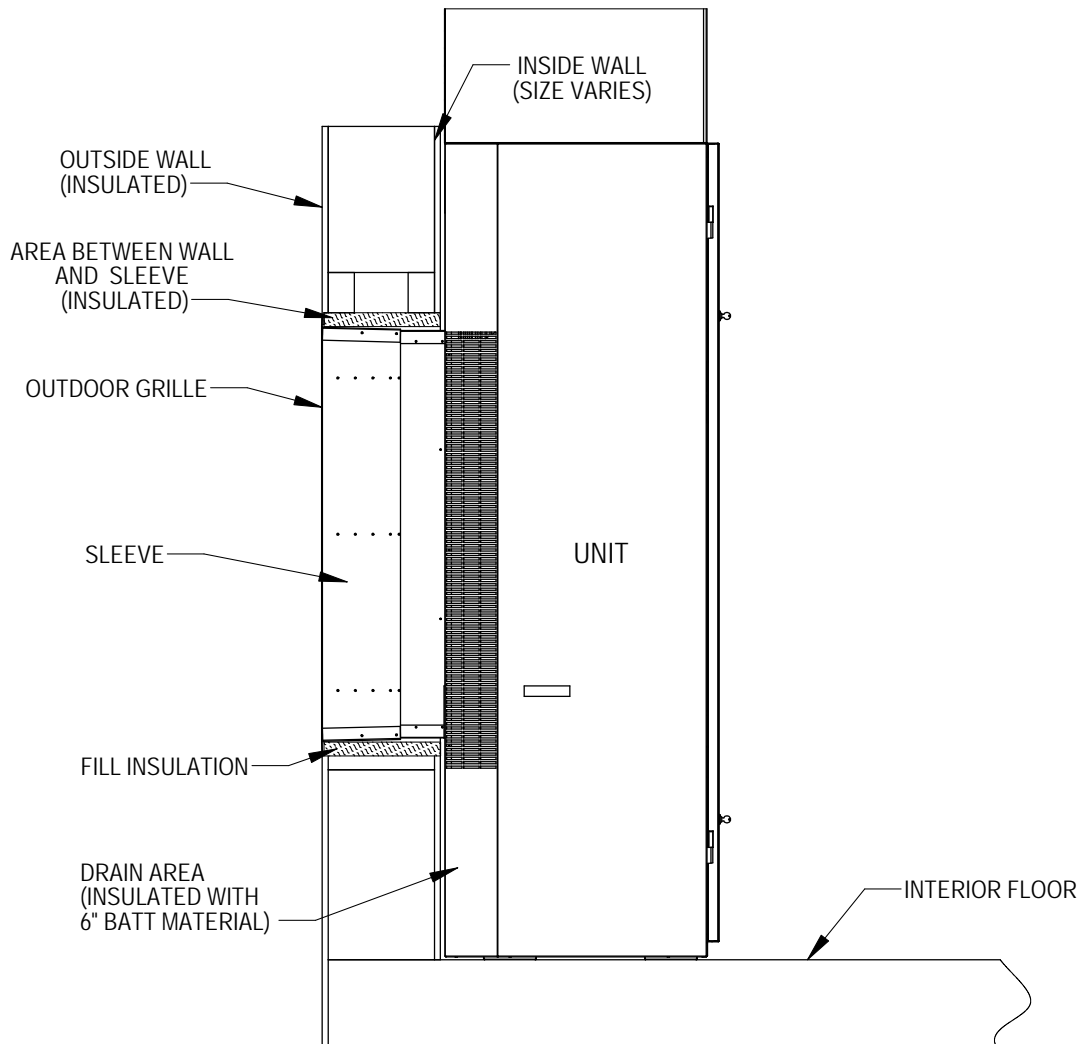

MIS-3201 A

**NOTICE:** *In order to achieve optimum sound reduction, the following areas need insulated:*

1. Outside wall.
2. Area between sleeve and wall.
3. Drain area behind unit.

# INSTALLATION

## Mounting the Unit

*The wall sleeve is attached to the I-TEC unit from the outside of the building. See Figures 9A and 9B. Refer to wall sleeve manual 2100-562 supplied with sleeve.*

Following are the steps for attaching the I-TEC to the wall sleeve.

1. Lift the unit into place making sure that it is aligned side-to-side. Align unit with rubber mat.
2. Push the unit back until the rear panel touches the sleeve gasket.
3. This unit must be level from side-to-side and from front-to-back. If adjustments are necessary, shim up under the base rails with sheets of metal or any substance not affected by moisture.
4. Attach the sleeve to the unit using the ten (10) 3/4" long self-tapping screws supplied with the sleeve.
5. The exhaust sleeve has three (3) 3/4" long screw slots in each side flange. Line these up with the screw engagement holes in the fan panel. Attach using six (6) 3/4" long pointed sheet metal screws supplied with the sleeve. Extend the sleeve out until it is flush with the louver grill attachment angles.
6. Lock the sleeve in place using two (2) 1/2" long pointed sheet metal screws on each side by shooting through the slot into a pre-punched hole.
7. A bottom trim piece is shipped loose for installation beneath the doors. Attach the trim piece to the unit with screws provided.
8. The compressor is secured to the base with two (2) bolts for shipping. Both bolts are identified with a tag. Remove shipping bolts (Figure 3).

## Wiring – Main Power

Refer to the unit rating plate and/or Table 2 for wire sizing information and maximum fuse or circuit breaker size. Each unit is marked with a "Minimum Circuit Ampacity". This means that the field wiring used must be sized to carry that amount of current. Depending on the installed KW of electric heat, there may be two field power circuits required. If this is the case, the unit serial plate will so indicate. All models are suitable only for connection with copper wire. Each unit and/or wiring diagram will be marked "Use Copper Conductors Only suitable for at least 75°C". **THESE INSTRUCTIONS MUST BE ADHERED TO.** Refer to the National Electrical Code (NEC) for complete current carrying capacity data on the various insulation grades of wiring material. All wiring must conform to NEC and all local codes.

The electrical data lists fuse and wire sizes (75°C copper) for all models, including the most commonly used heater sizes. Also shown are the number of field power circuits required for the various models with heaters.

The unit rating plate lists a "Maximum Time Delay Relay Fuse" or circuit breaker that is to be used with the equipment. The correct size must be used for proper circuit protection and also to ensure that there will be no nuisance tripping due to the momentary high starting current of the compressor motor.

See "START UP" section for information on three phase scroll compressor start-ups.

The field wiring conduit connections are located on the top right-hand corner of the unit with a wire raceway to feed the wires down to the circuit breaker(s). See Figure 10.

**FIGURE 10**  
**Component Location**

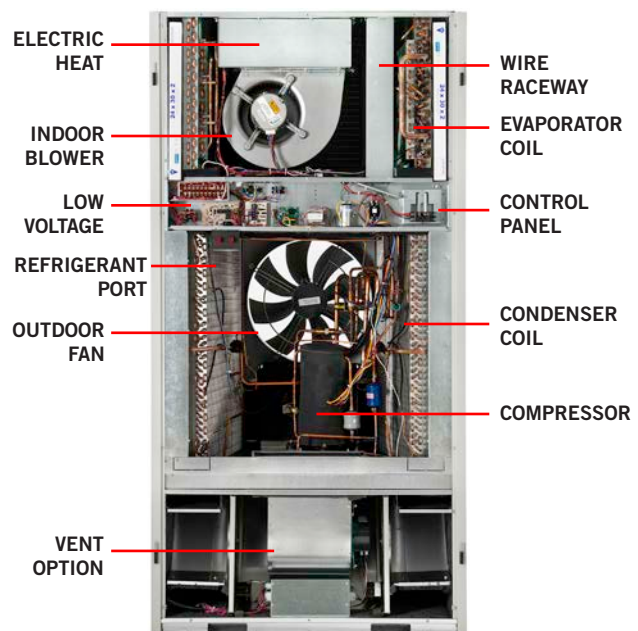

## Wiring – Low Voltage Wiring

### 230/208V, 1 Phase and 3 Phase Equipment Dual Primary Voltage Transformers

All equipment leaves the factory wired on 240V tap. For 208V operation, reconnect from 240V to 208V tap. The acceptable operating voltage range for the 240 and 208V taps are as noted in Table 3.

**TABLE 3 – Operating Voltage Range**

TAP	RANGE
240V	253 – 216
208V	220 – 187

**NOTE:** The voltage should be measured at the field power connection point in the unit and while the unit is operating at full load (maximum amperage operating condition).

The standard unit includes a remote thermostat connection terminal strip. See Figures 11 through 16 for connection diagrams. Compatible thermostats are listed in Table 4.

**TABLE 4 – Wall Thermostats**

Thermostat	Predominant Features
8403-060 (1120-445)	3 Stage Cool; 3 Stage Heat Programmable/Non-Programmable Electronic HP or Conventional Auto or Manual changeover
8403-096 (CDT-2W40-LCD-RLY)	Carbon Dioxide Sensor with LCD for Sensor Readings
8403-084 (VT8600U5000B)	2 stage Cool; 2 stage Heat Programmable/Non-Programmable Electronic HP or Conventional, Auto or Manual changeover with BACnet
CS9B-TH0A	3 Stage Heat, 3 Stage Cool, Prog/ NonProg, HP or Conv, Auto or Manual Changeover, Humidity Sensor w/dehumidification, Motion Sensor w/Intelligent Learning Control, BACnet-compatible
CS9B-THOCA	3 Stage Heat, 3 Stage Cool, Prog/ NonProg, HP or Conv, Auto or Manual Changeover, Humidity Sensor w/dehumidification, CO <sub>2</sub> Sensor, Motion Sensor w/Intelligent Learning Control, BACnet-compatible
CS9BE-TH0A	3 Stage Heat, 3 Stage Cool, Prog/ NonProg, HP or Conv, Auto or Manual Changeover, Humidity Sensor w/dehumidification, Motion Sensor, Intelligent Learning Control, BACnet-compatible, Ethernet-compatible
CS9BE-THOCA	3 Stage Heat, 3 Stage Cool, Prog/ NonProg, HP or Conv, Auto or Manual Changeover, Humidity Sensor w/ dehumidification, CO <sub>2</sub> Sensor, Motion Sensor w/Intelligent Learning Control, BACnet-compatible, Ethernet-compatible

## Low Voltage Connections

These units use a grounded 24 volt AC low voltage circuit.

“G” terminal is the *fan input*.

“Y1” terminal is the *compressor part load input*.

“Y2” terminal is the *compressor full load input*.

“B/W1” terminal is the *reversing valve input*. The reversing valve must be energized for heating mode.

“R” terminal is *24 VAC hot*.

“C” terminal is *24 VAC grounded*.

“L” terminal is *compressor lockout output*. This terminal is activated on a high or low pressure trip and

condensate overflow trip by the electronic heat pump control. This is a 24 VAC output.

“W2” terminal is *first stage electric heat* (if equipped). First stage electric heat can be operated simultaneously with the heat pump operating.

“A” terminal is the *ventilation input*. This terminal energizes any factory-installed ventilation option.

“W3” terminal is *second stage electric heat*. When “W3” terminal is energized, it locks out compressor operation to limit discharge air temperature and required branch circuit ampacity.

**NOTE:** For total and proper control using DDC, a minimum of nine (9) controlled outputs are needed when above 10KW electric heat is employed with ventilation, a total of eight (8) controlled outputs with below 10KW electric heat with ventilation, seven (7) controlled outputs below 10KW electric heat with no ventilation, seven (7) controlled outputs with no electric heat (but with ventilation) and six (6) controlled outputs with no electric heat and no ventilation. If dehumidification model and vent, ten (10) controlled outputs are needed when above 10KW electric heat is employed with ventilation.

Low Voltage Connections for DDC Control	
Fan Only	Energize G
Cooling Part Load	Energize G, Y1
Cooling Full Load	Energize G, Y1, Y2
HP Heating Part Load	Energize G, Y1, B/W1
HP Heating Full Load	Energize G, Y1, Y2, B/W1
HP Heating Full Load + Electric Heat (up to 10KW)	Energize G, Y1, Y2, B/W1, W2
Heating with Bank #1 Electric Heat Only	Energize G, W2
Emergency Heat ( <i>Heat pump operation is negated for this condition</i> )	Energize G, W2, W3
Ventilation	Energize A

## General

This unit is equipped with a variable speed ECM motor. The motor is designed to maintain rated airflow up to the maximum static allowed. ***It is important that the blower motor plugs are not plugged in or unplugged while the power is on. Failure to remove power prior to unplugging or plugging in the motor could result in motor failure.***



## CAUTION

***Do not plug in or unplug blower motor connectors while the power is on. Failure to do so may result in motor failure.***

**FIGURE 11**  
**Basic Heat Pump with No Ventilation Package**

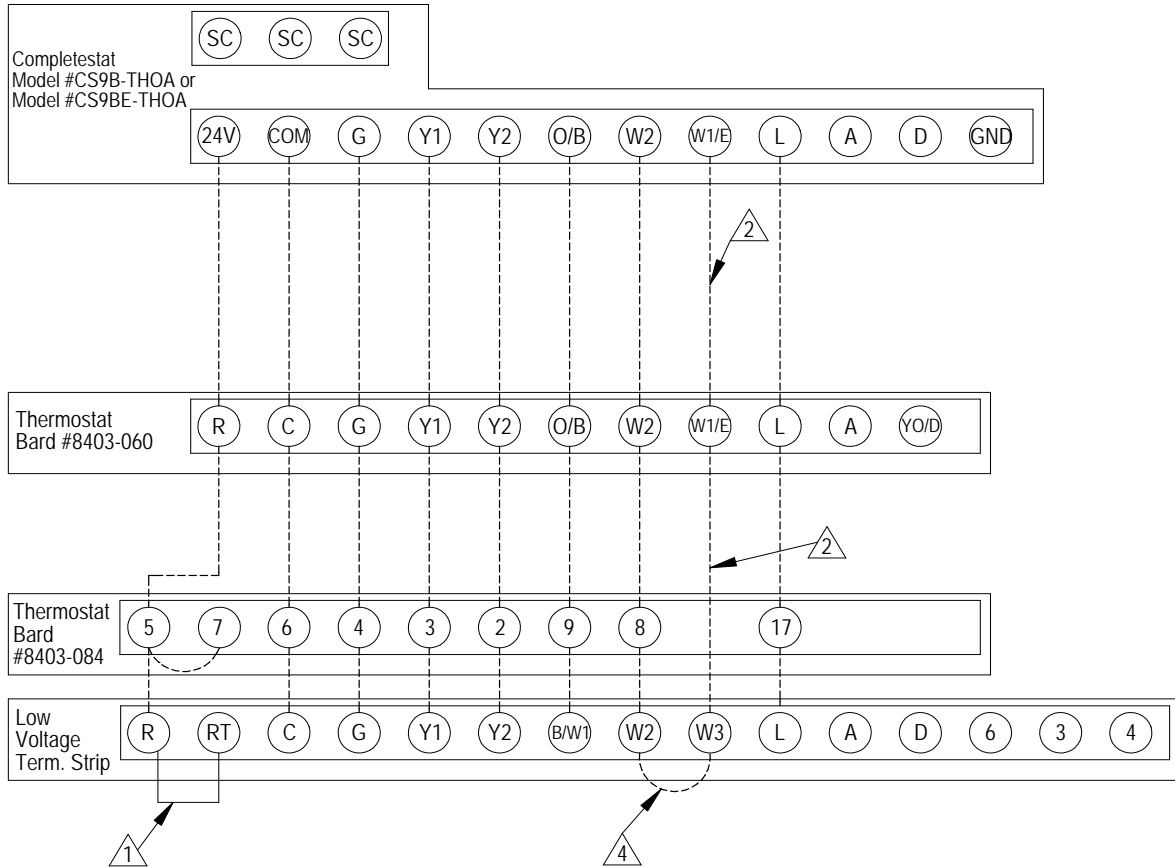

- ① Factory installed jumper. Remove jumper and connect to N.C fire alarm
- ② Not needed below 15KW
- ③ Relay Provided with Completestat
- ④ Jumper W2 to W3 at terminal block when using 8403-084 with unit with 15 KW

MIS-3203 C

**FIGURE 12**  
Heat Pump with CRV, without CO<sub>2</sub> Control

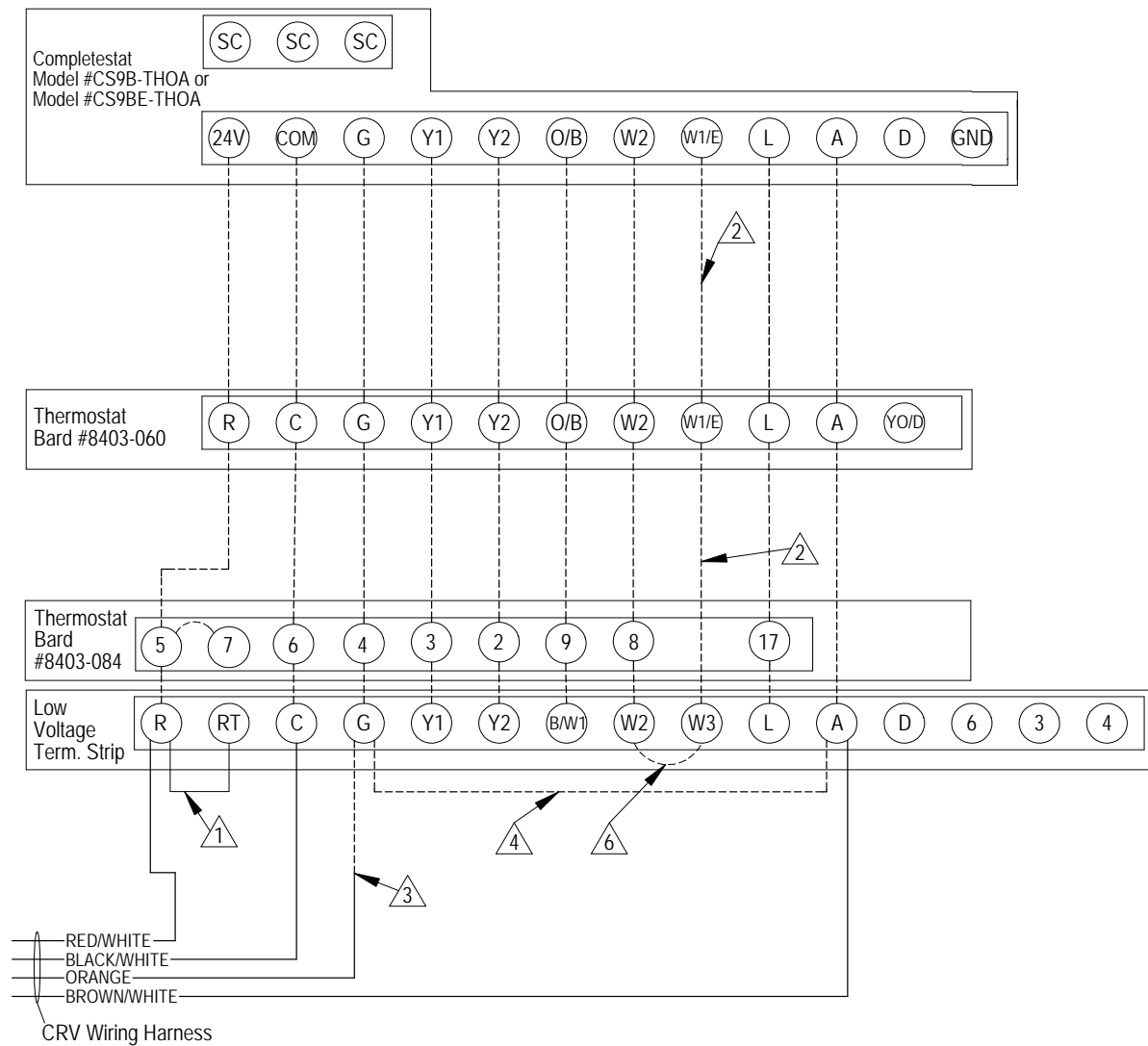

- |  |   |
|--|---|
| <p>△1 Factory installed jumper. Remove jumper and connect to N.C fire alarm circuit if emergency shutdown required.</p> <p>△2 Not needed below 15KW.</p> <p>△3 Connect to "G" terminal when thermostat has "Occupancy Signal".</p> | <p>△4 Install a jumper between "G" and "A" only when thermostat without "Occupancy Signal" is used.</p> <p>△5 Relay Provided with Completestat</p> <p>△6 Jumper W2 to W3 at terminal block when using 8403-084 with unit with 15 KW</p> |
|--|---|

MIS-3204 C

**FIGURE 13**  
Heat Pump with CRV and CO<sub>2</sub> Control

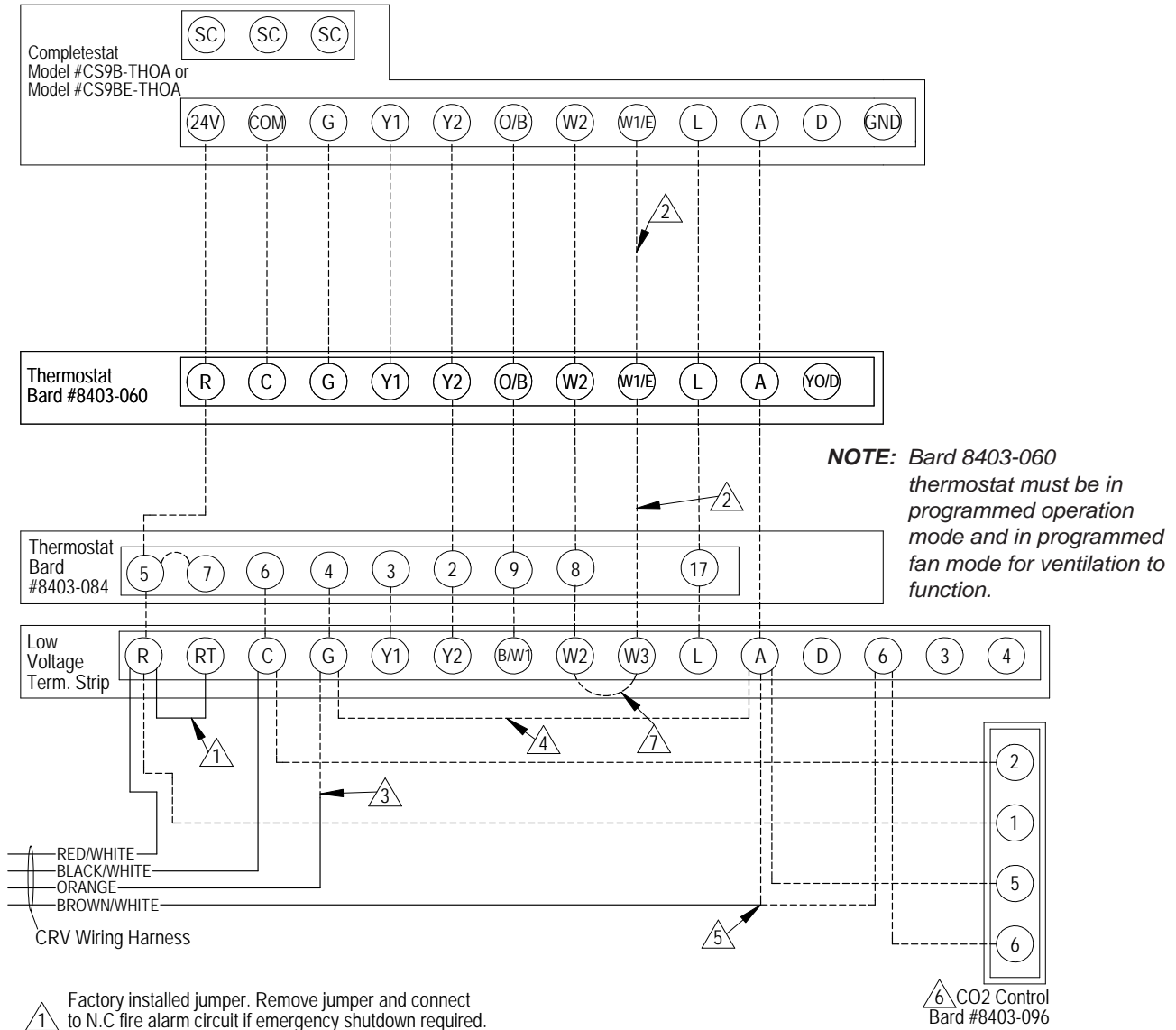

1 Factory installed jumper. Remove jumper and connect to N.C fire alarm circuit if emergency shutdown required.

2 Not needed below 15KW.

3 Connect to "G" terminal when thermostat has "Occupancy Signal".

4 Install a jumper between "G" and "A" only when thermostat without "Occupancy Signal" is used.

5 If CS9B-THOC or CS9BE-THOC is used, connect "Brown/White" directly to "A" and do not use separate CO2 controller.

6 Relay Provided with Completestat

7 Jumper W2 to W3 at terminal block when using 8403-084 with unit with 15 KW.

MIS-3205 D

These units require R-410A refrigerant and Polyol Ester oil.

## General

1. Use separate service equipment to avoid cross contamination of oil and refrigerants.
2. Use recovery equipment rated for R-410A refrigerant.
3. Use manifold gauges rated for R-410A (800 psi/250 psi low).
4. R-410A is a binary blend of HFC-32 and HFC-125.
5. R-410A is nearly azeotropic—similar to R-22 and R-12. Although nearly azeotropic, charge with liquid refrigerant.
6. R-410A operates at 40-70% higher pressure than R-22 and systems designed for R-22 cannot withstand this higher pressure.
7. R-410A has an ozone depletion potential of zero, but must be reclaimed due to its global warming potential.
8. R-410A compressors use Polyol Ester oil.
9. Polyol Ester oil is hygroscopic; it will rapidly absorb moisture and strongly hold this moisture in the oil.
10. A liquid line dryer must be used; even a deep vacuum will not separate moisture from the oil.
11. Limit atmospheric exposure to 15 minutes.
12. If compressor removal is necessary, always plug compressor immediately after removal. Purge with small amount of nitrogen when inserting plugs.

## Topping Off System Charge

If a leak has occurred in the system, Bard Manufacturing recommends reclaiming, evacuating (see criteria above) and charging to the nameplate charge. However, if done correctly, topping off the system charge can be done without problems.

With R-410A, there are no significant changes in the refrigerant composition during multiple leaks and recharges. R-410A refrigerant is close to being an azeotropic blend (it behaves like a pure compound or single component refrigerant). The remaining refrigerant charge, in the system, may be used after leaks have occurred and then “top-off” the charge by utilizing the charging charts on the inner control panel cover as a guideline.

REMEMBER: When adding R-410A refrigerant, it must come out of the charging cylinder/tank as a liquid to avoid any fractionation and to ensure optimal system performance. Refer to instructions for the cylinder that is being utilized for proper method of liquid extraction.



## Safety Practices

1. Never mix R-410A with other refrigerants.
2. Use gloves and safety glasses. Polyol Ester oils can be irritating to the skin and liquid refrigerant will freeze the skin.
3. Never use air and R-410A to leak check; the mixture may become flammable.
4. Do not inhale R-410A—the vapor attacks the nervous system, creating dizziness, loss of coordination and slurred speech. Cardiac irregularities, unconsciousness and ultimately death can result from breathing this concentration.
5. Do not burn R-410A. This decomposition produces hazardous vapors. Evacuate the area if exposed.
6. Use only cylinders rated DOT4BA/4BW 400.
7. Never fill cylinders over 80% of total capacity.
8. Store cylinders in a cool area, out of direct sunlight.
9. Never heat cylinders above 125°F.
10. Never trap liquid R-410A in manifold sets, gauge lines or cylinders. R-410A expands significantly at warmer temperatures. Once a cylinder or line is full of liquid, any further rise in temperature will cause it to burst.

## Description of Standard Equipment

### Solid State Electronic Heat Pump Control

Provides efficient 30-, 60- or 90-minute defrost cycle. A thermistor sensor and speed up terminal for service along with a 8-minute defrost override are standard on the electronic heat pump control. By default, the I-TEC are factory shipped on the 90-minute defrost cycle.

### High/Low Pressure Switch

Provides refrigerant circuit high pressure and loss of charge protection. Includes lockout circuit built into heat pump control that is resettable from room thermostat.

### Five Minute Compressor Time Delay

Provides short cycle protection for the compressor which extends compressor life. Built into the electronic heat pump control as standard.

### Condensate Overflow

Senses and provides system shut down if draining issue causes water level to rise in the lower drain pan.

### Low Ambient Control

The low ambient control permits cooling operation down to 0°F outdoor ambient.

### Important Installer Note

For improved start-up performance, wash the indoor coil with a dishwasher detergent.

### Phase Monitor

All units with three phase scroll compressors are equipped with a three phase line monitor to prevent compressor damage due to phase reversal.

The phase monitor in this unit is equipped with two LEDs. If the Y signal is present at the phase monitor and phases are correct, the green LED will light and the compressor contactor is allowed to energize.

If phases are reversed, the red fault LED will be lit and compressor operation is inhibited.

If a fault condition occurs, reverse two of the supply leads to the unit. Do not reverse any of the unit factory wires as damage may occur.

### Three Phase Scroll Compressor Start Up Information

Scroll compressors, like several other types of compressors, will only compress in one rotational direction. Direction of rotation is not an issue with single phase compressors since they will always start and run in the proper direction.

However, three phase compressors will rotate in either direction depending upon phasing of the power. Since there is a 50-50 chance of connecting power in such a way as to cause rotation in the reverse

direction, **verification of proper rotation must be made.** Verification of proper rotation direction is made by observing that suction pressure drops and discharge pressure rises when the compressor is energized. Reverse rotation also results in an elevated sound level over that with correct rotation, as well as substantially reduced current draw compared to tabulated values.

**Verification of proper rotation must be made at the time the equipment is put into service. If improper rotation is corrected at this time, there will be no negative impact on the durability of the compressor. However, reverse operation for even 1 hour may have a negative impact on the bearing due to oil pump out.**

All three phase scroll compressors used in the I-TEC series are wired identically internally. As a result, once the correct phasing is determined for a specific system or installation, connecting properly phased power leads to the same Fusite terminal should maintain proper rotation direction. The direction of rotation of the motor may be changed by reversing any two line connections to the unit.

### Service Hints

1. Caution user to maintain clean air filters at all times and to not needlessly close off supply air registers. This may reduce airflow through the system, which shortens equipment service life as well as increasing operating costs and noise levels.
2. Switching to heating cycle at 75°F or higher outside temperature may cause a nuisance trip of the remote reset high pressure switch. Turn thermostat off, then on to reset the high pressure switch.
3. The heat pump wall thermostats perform multiple functions. Be sure that all function switches are correctly set for the desired operating mode before trying to diagnose any reported service problems.
4. Check all power fuses or circuit breakers to be sure they are the correct rating.
5. Periodic cleaning of the outdoor coils to permit full and unrestricted airflow circulation is essential.
6. Annual maintenance is required to make sure that all of the systems are functioning properly.
  - a. Check to make sure that the drains are not obstructed in any way.
  - b. Remove any debris in the condenser section of the unit.
  - c. Inspect and wash outdoor coils as necessary.
7. All motors are sealed and require no oiling.

## Sequence of Operation

### Cooling Part Load

Circuit R-Y1 makes at thermostat pulling in compressor contactor, starting the compressor and outdoor motor. The G (indoor motor) circuit is automatically completed on any call for cooling operation or can be energized by manual fan switch on subbase for constant air circulation.

### Cooling Full Load

Circuit R-Y1 & Y2 makes at the thermostat energizing the 2nd stage solenoid in the compressor. The default position of the compressor staging solenoid is non-energized. The compressor will run at low capacity until this solenoid is energized.

### Heating Stage 1

A 24V solenoid coil on reversing valve controls heating cycle operation. Two thermostat options, one allowing "Auto" changeover from cycle to cycle and the other constantly energizing solenoid coil during heating season and thus eliminating pressure equalization noise except during defrost, are to be used. On "Auto" option, a circuit is completed from R-B and R-Y1 on each heating "on" cycle, energizing reversing valve solenoid and pulling in compressor contactor starting compressor and outdoor motor. R-G also make starting indoor blower motor. Heat pump heating cycle now in operation. The second option has no "Auto" changeover position, but instead energizes the reversing valve solenoid constantly whenever the system switch on subbase is placed in "Heat" position, the "B" terminal being constantly energized from R. A thermostat demand for Stage 1 heat completes R-Y1 circuit, pulling in compressor contactor starting compressor and outdoor motor. R-G also make starting indoor blower motor.

### Heating Stage 2

Circuit R-Y1 & Y2 makes at the thermostat energizing the 2nd stage solenoid in the compressor.

## Pressure Service Ports

High and low pressure service ports are installed on all units so that the system operating pressures can be observed. Pressure tables can be found later in the manual covering all models. It is imperative to match the correct pressure table to the unit by model number. Upper and lower service doors must be attached to obtain proper reading.

This unit employs high-flow Coremax valves instead of the typical Shrader type valves.

***WARNING! Do NOT use a Schrader valve core removal tool with these valves. Use of such a tool could result in eye injuries or refrigerant burns!***

To change a Coremax valve without first removing the refrigerant, a special tool is required which can be obtained at [www.fastestinc.com/en/SCCA07H](http://www.fastestinc.com/en/SCCA07H). See the replacement parts manual for replacement core part numbers.

## Defrost Cycle

The defrost cycle is controlled by temperature and time on the solid state heat pump control (see Figure 14).

When the outdoor temperature is in the lower 40°F temperature range or colder, the outdoor coil temperature is 32°F or below. This coil temperature is sensed by the coil temperature sensor mounted near the bottom of the outdoor coil. Once coil temperature reaches 30°F or below, the coil temperature sensor sends a signal to the control logic of the heat pump control and the defrost timer will start accumulating run time.

After 30, 60 or 90 minutes of heat pump operation at 30°F or below, the heat pump control will place the system in the defrost mode. Factory default setting is 90 minutes.

During the defrost mode, the refrigerant cycle switches back to the cooling cycle, the outdoor motor stops, electric heaters are energized and hot gas passing through the outdoor coil melts any accumulated frost. When the temperature rises to approximately 57°F, the coil temperature sensor will send a signal to the heat pump control which will return the system to heating operations automatically.

If some abnormal or temporary condition such as a high wind causes the heat pump to have a prolonged defrost cycle, the heat pump control will restore the system to heating operation automatically after 8 minutes.

The heat pump defrost control board has an option of 30-, 60- or 90-minute setting. All models are shipped from the factory on the 90-minute pin. If special circumstances require a change to another time, remove the wire from the 90-minute terminal and reconnect to the desired terminal.

The manufacturer's recommendation is for 90-minute defrost cycles. Refer to Figure 14.

There is a cycle speed up jumper on the control. This can be used for testing purposes to reduce the time between defrost cycle operation without waiting for time to elapse.

Use a small screwdriver or other metallic object, or another ¼" QC, to short between the *SPEEDUP* terminals to accelerate the HPC timer and initiate defrost.

Be careful not to touch any other terminals with the instrument used to short the *SPEEDUP* terminals. It may take up to 15 seconds with the *SPEEDUP* terminals shorted for the speedup to be completed and the defrost cycle to start.

**As soon as the defrost cycle kicks, in remove the shorting instrument from the *SPEEDUP* terminals.** Otherwise the timing will remain accelerated and run through the 1-minute minimum defrost length sequence in a matter of seconds and will automatically terminate the defrost sequence.

There is an initiate defrost jumper (*SEN JMP*) on the control that can be used at any outdoor ambient during the heating cycle to simulate a 0° coil temperature.

This can be used to check defrost operation of the unit without waiting for the outdoor ambient to fall into the defrost region.

By placing a jumper across the *SEN JMP* terminals (a ¼" QC terminal works best) the defrost sensor mounted on the outdoor coil is shunted out and will activate the timing circuit. This permits the defrost cycle to be checked out in warmer weather conditions without the outdoor temperature having to fall into the defrost region.

**In order to terminate the defrost test, the *SEN JMP* jumper must be removed.** If left in place too long, the compressor could stop due to the high pressure condition created by operating in the cooling mode with outdoor fan off. Pressure will rise rapidly as there is likely no actual frost on the outdoor coil in this artificial test condition.

There is also a 5-minute compressor time delay function built into the Heat Pump Control to protect the compressor from short cycling conditions. The board's LED will have a fast blink rate when in the compressor time delay function. In some instances, it is helpful to the service technician to override or speed up this timing period, and shorting out the *SPEEDUP* terminals for a few seconds can do this.

**FIGURE 14**  
**Heat Pump Control**  
**Defrost Cycle**

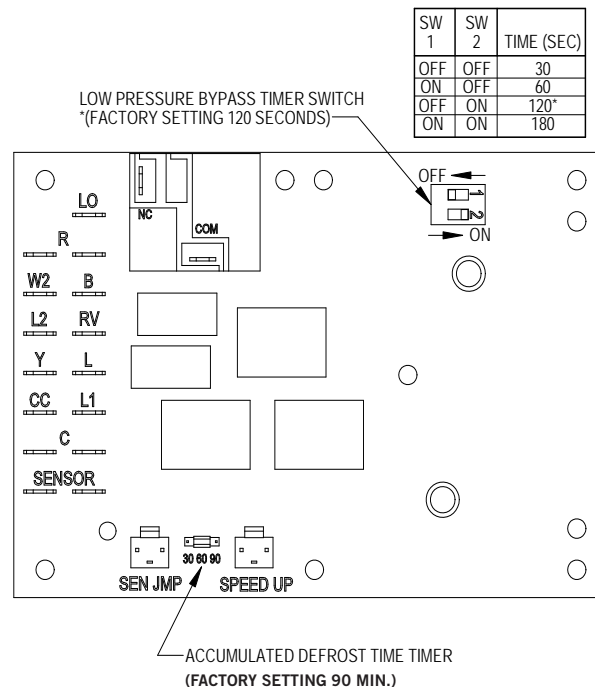

MIS-2668 A

# I-TEC COMMERCIAL ROOM VENTILATOR SYSTEM

## General Description

The I-TEC Commercial Room Ventilator (CRV) is designed to be used with all Bard I-TEC models. The only intent of this device is to provide the required ventilation by delivering fresh air to meet IAQ (Indoor Air Quality) requirements. In the installed application, this system also includes exhaust provisions which are balanced with the intake air to maintain building pressurization requirements of ASHRAE 62.1 Standard.

Ventilation is accomplished with two blower/motor assemblies for maximum ventilation at low sound levels. The intake and exhaust blowers are programmed independently and are balanced to maintain a slight positive pressurization in accordance to ASHRAE 62.1 Standard.

The I-TEC CRV is also provided with filters to reduce the required service needed and to further improve the IAQ. The exhaust air blowers and intake air blowers are protected by two (2) throw away filters. Both are accessible without the need for tools.

## Control Wiring

The I-TEC CRV comes wired from the factory set to 450 CFM of ventilation. Care must be taken when deciding how to control the operation of the ventilator. When designing the control circuit for the ventilator, the following requirements must be met.

1. The indoor blower must be run whenever the I-TEC CRV is run.
2. Select and configure the correct CFM ventilation level that the I-TEC CRV needs to operate and configure the system to this level following later instructions within this section. Over ventilating serves no useful purpose and significantly affects the overall efficiency of the heat pump system. System operating costs would also increase.
3. Run the I-TEC CRV only during periods when the conditioned space is occupied. Running the ventilation during unoccupied periods wastes energy, decreases the expected life of the CRV and can result in large moisture buildup in the structure. Running the CRV when the structure is unoccupied allows moisture to build up in the structure because there is little or no cooling load. Thus, the air conditioner is not running enough to remove the excess moisture being brought in. Use a control system that in some way can control the system based upon occupancy.

## NOTICE

Operating the I-TEC CRV during unoccupied periods can result in a build up of excess moisture in the structure.

## Recommended Control Sequences

Several possible scenarios are listed below:

1. Use a programmable electronic thermostat with auxiliary terminal to control the CRV based on daily programmed occupancy periods. Bard markets and recommends Bard Part #8403-060 programmable electronic thermostat.
2. Use Bard CompleteStat™ that incorporates temperature, humidity and occupancy control with learning capability into a single device. No programming required.
3. Use a DDC control system to control the CRV based upon a room occupancy schedule to control the CRV.
4. Tie the operation of the CRV into the light switch. The lights in a room are usually on only when occupied.
5. Use a manual timer that the occupants turn to energize the CRV for a specific number of hours.
6. Use a programmable mechanical timer to energize the CRV and indoor blower during occupied periods of the day.

**NOTE:** The ventilation package comes with a blower interlock function, but is disabled when it is shipped from the factory in case a thermostat with an occupancy output or occupancy sensor is not utilized and "A" terminal to "G" terminal must be tied to drive the ventilation package. If a thermostat or control does drive occupancy output, remove the tape from the orange wire located in the low voltage terminal box and connect it to the "G" terminal to activate this function (see Figures 11-13).

## Setting the Ventilation CFM Levels

The I-TEC CRV has four pre-set levels of ventilation CFM available. These are 300, 375, 450 and 525 CFM of ventilation air. The I-TEC CRV is shipped from the factory set on the 450 CFM ventilation level. To change between these four different levels of provided ventilation CFM, first refer to Figure 15 to look up the corresponding CFM needed for the intake and exhaust blowers to meet the design criteria and determine which “speed/wire color” is needed. Then, perform the following steps.

WARNING

- HAZARD OF ELECTRICAL SHOCK.
- ELECTRICAL SHOCK CAN RESULT IN SERIOUS INJURY OR DEATH.
- DISCONNECT THE REMOTE ELECTRIC POWER SUPPLY OR SUPPLIES BEFORE SERVICING.

7961-755-1

1. Open front swinging doors of main unit (by popping front door latches).
2. Throw main power disconnect to the “OFF” position to eliminate risk of injury or death due to electrical shock.
3. Remove six (6) screws holding front CRV door in place (see Figure 16).
4. Locate brown wire with white trace that has a black terminal on the end where it connects to the terminal strip (see Figure 15).
5. Move brown wire with white trace to the corresponding CFM level needed in accordance with Figure 15.

**FIGURE 15**  
**CRV Motor Speed/CFM Configuration**

VENT OPTION INTAKE/EXHAUST SPEEDS		
WIRE COLOR	SPEED	NOM. CFM
BLACK	HI	525
BLUE	MED-HI	450
ORANGE	MED-LO	375
RED	LO	300

TO CHANGE SPEEDS, MOVE BROWN WIRE WITH WHITE TRACE.

7961-755-2

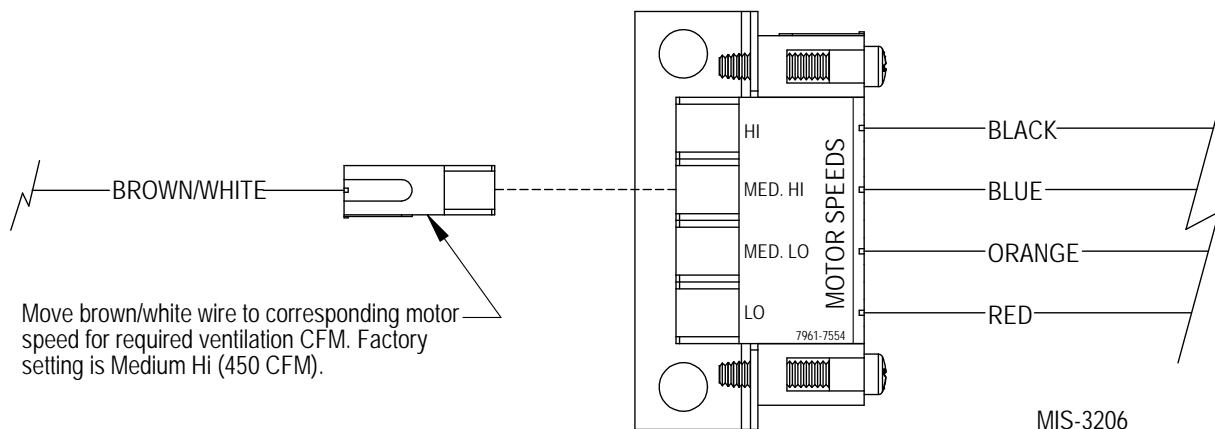

**FIGURE 16**  
**CRV Speed Change Terminal Access**

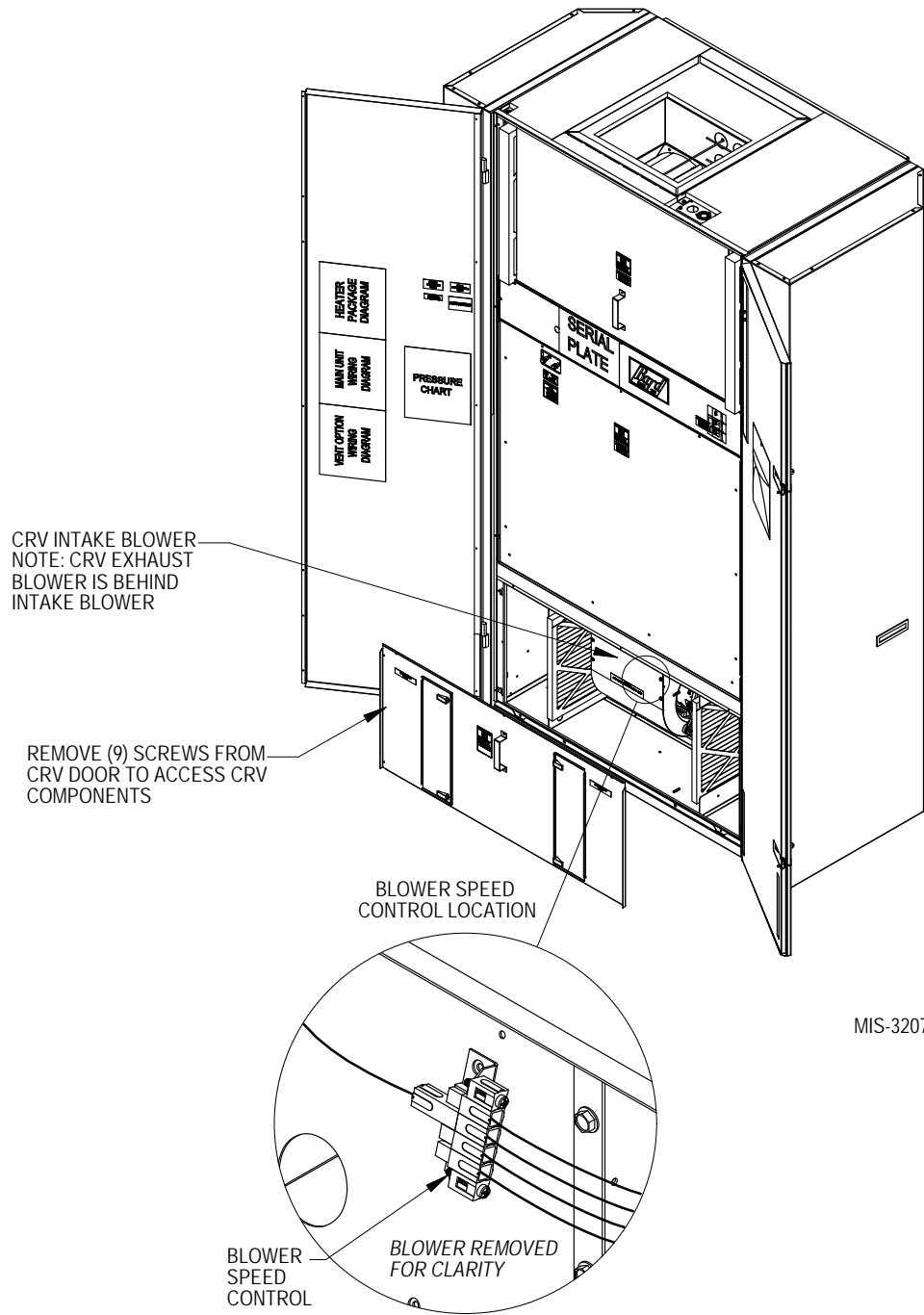

**FIGURE 17**  
**Ventilation Airflow Diagram**

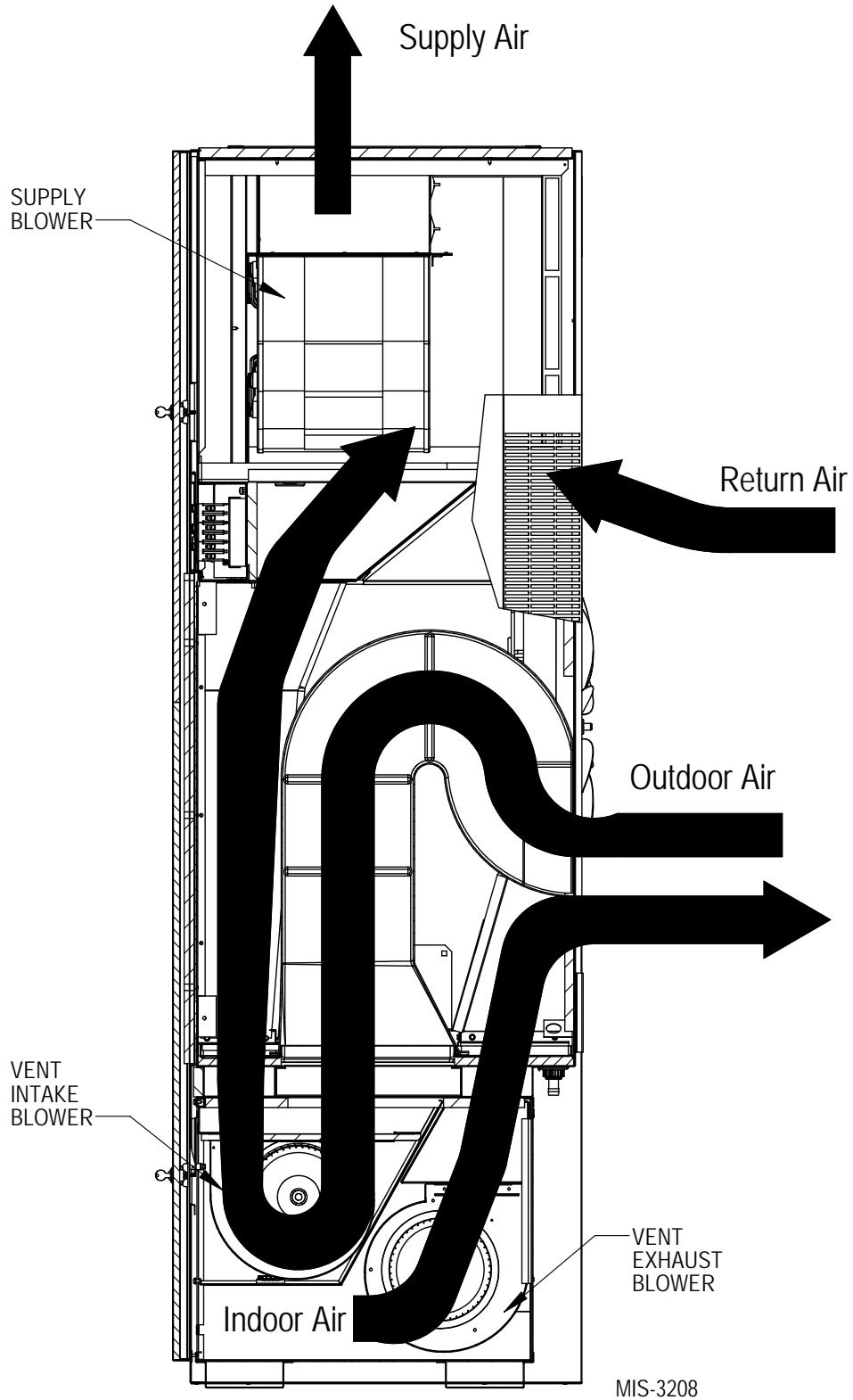

# TROUBLESHOOTING

## Solid State Heat Pump Control

1. **NOTE:** A thorough understanding of the defrost cycle sequence is essential. Review that section on page 28 prior to troubleshooting the control. Turn on AC power supply to unit.
2. Turn thermostat blower switch to “fan on”—the indoor blower should start. (If it doesn't, troubleshoot indoor unit and correct problem.)
3. Turn thermostat blower to “auto” position. Indoor blower should stop.
4. Set system switch to “heat” or “cool”. Adjust thermostat to call for heat or cool. The indoor blower, compressor and outdoor fan should start.

**NOTE:** If there was no power to 24 volt transformer, the compressor and outdoor fan motor will not start for 5 minutes. This is because of the compressor short cycle protection.

Code	Function
Slow Blink	Normal Operation
Fast Blink	Compressor Time Delay
1 Blink	Low Pressure Switch Failure
2 Blink	High Pressure Switch Failure or Condensate Overflow Switch Activated
3 Blink	Defrost Mode Active
4 Blink	High Pressure or Overflow Switch Lockout

**TABLE 5 – Troubleshooting**

Symptom	Description, Check & Possible Causes	What & How to Check / Repair
Compressor will not start (heating or cooling)	<b>1. Check for LED illumination.</b> Is there an LED illuminated on the board (flashing)?	Yes = go to Step #2; No = go to Step #3
	<b>2. Check for error codes.</b> Is the LED flashing a Code?	Yes = go to Step #4; No = go to Step #8
	<b>3. Check for power at board.</b> Is there 24 volts AC between R and C?	Yes = go to Step #13; No = go to Step #9
	<b>4. Check codes.</b> What code is blinking?	Code "1", go to Step #6; Code "2", go to Steps #7A & #7B; Fast Blink, go to Step #5
	<b>5. Compressor delay active.</b> Wait for 5 minute delay or jump board's "speed up pins".	Check for proper operation; if still needed, go back to Step #1.
	<b>6. Low pressure fault.</b>	Check wiring circuit and unit pressures.
	<b>7A. High pressure fault.</b>	Check wiring circuit and unit pressures.
	<b>7B. Condensate overflow fault.</b>	Check upper indoor coil drains; check lower outdoor coil drains; check main drain line.
	<b>8. Check for Compressor input signal.</b> Is there 24 volts AC between Y and C?	Yes = go to Step #10; No = go to Step #11
	<b>9. No power to board.</b>	The unit either does not have unit voltage, the transformer is bad or the unit wiring is incorrect.
	<b>10. Check for Compressor output signal.</b> Is there 24 volts AC between CC & C?	Yes = go to Step #12; No = go to Step #13
	<b>11. No "Y" compressor input signal.</b>	Check thermostat wiring, incorrect phase of unit (see section on Phase Monitor), and finally unit wiring.
	<b>12. No "CC" compressor output signal.</b>	Check compressor contactor for proper operation and finally check compressor.
<b>13. Faulty board.</b>	Replace defrost board.	
Fan outdoor motor does not run (cooling or heating except during defrost)	Heat pump control defective	Check across fan relay on heat pump control. (Com-NC) Replace heat pump control.
	Motor defective	Check for open or shorted motor winding. Replace motor.
	Motor capacitor defective	Check capacitor rating. Check for open or shorted capacitor. Replace capacitor.
Reversing valve does not energize (heating only)	Heat pump control defective	Check for 24V between RV-C and B-C. 1. Check control circuit wiring. 2. Replace heat pump control
	Reversing valve solenoid coil defective	Check for open or shorted coil. Replace solenoid coil.
Unit will not go into defrost (heating only)	Temperature sensor or heat pump control defective	Disconnect temperature sensor from board and jumper across "SPEEDUP" terminals and "SEN JMP" terminals. This should cause the unit to go through a defrost cycle within 1 minute. 1. If unit goes through defrost cycle, replace temperature sensor. 2. If unit does not go through defrost cycle, replace heat pump control.
Unit will not come out of defrost (heating only)	Temperature sensor or heat pump control defective.	Jumper across "SPEEDUP" terminal. This should cause the unit to come out of defrost within 1 minute. 1. If unit comes out of defrost cycle, replace temperature sensor. 2. If unit does not come out of defrost cycle, replace heat pump control.

## Checking Temperature Sensor

1. Disconnect temperature sensor from board and from right-hand outdoor coil.
2. Use an ohmmeter and measure the resistance of the sensor. Also use ohmmeter to check for short or open.
3. Check resistance reading to chart of resistance use sensor ambient temperature. (Tolerance of part is  $\pm 10\%$ .)
4. If sensor resistance reads very low, then sensor is shorted and will not allow proper operation of the heat pump control.
5. If sensor is out of tolerance, shorted, open or reads very low ohms, it should be replaced.

**TABLE 6**  
**Temperature (F) vs. Resistance (R) of Temperature Sensor**

F	R	F	R	F	R	F	R
-25	196871	13	56985	51	19374	89	7507
-24	190099	14	55284	52	18867	90	7334
-23	183585	15	53640	53	18375	91	7165
-22	177318	16	52051	54	17989	92	7000
-21	171289	17	50514	55	17434	93	6840
-20	165487	18	49028	56	16984	94	6683
-19	159904	19	47590	57	16547	95	6531
-18	154529	20	46200	58	16122	96	6383
-17	149355	21	44855	59	15710	97	6239
-16	144374	22	43554	60	15310	98	6098
-15	139576	23	42295	61	14921	99	5961
-14	134956	24	41077	62	14544	100	5827
-13	130506	25	39898	63	14177	101	5697
-12	126219	26	38757	64	13820	102	5570
-11	122089	27	37652	65	13474	103	5446
-10	118108	28	36583	66	13137	104	5326
-9	114272	29	35548	67	12810	105	5208
-8	110575	30	34545	68	12492	106	5094
-7	107010	31	33574	69	12183	107	4982
-6	103574	32	32634	70	11883	108	4873
-5	100260	33	31723	71	11591	109	4767
-4	97064	34	30840	72	11307	110	4663
-3	93981	35	29986	73	11031	111	4562
-2	91008	36	29157	74	10762	112	4464
-1	88139	37	28355	75	10501	113	4367
0	85371	38	27577	76	10247	114	4274
1	82699	39	26823	77	10000	115	4182
2	80121	40	26092	78	9760	116	4093
3	77632	41	25383	79	9526	117	4006
4	75230	42	24696	80	9299	118	3921
5	72910	43	24030	81	9077	119	3838
6	70670	44	23384	82	8862	120	3757
7	68507	45	22758	83	8653	121	3678
8	66418	46	22150	84	8449	122	3601
9	64399	47	21561	85	8250	123	3526
10	62449	48	20989	86	8057	124	3452
11	60565	49	20435	87	7869		
12	58745	50	19896	88	7686		

## Troubleshooting Condensate Overflow Systems

The Bard I-TEC Series is equipped with dual condensate overflow switches. One switch (float type) is located in the indoor drain pan. It is secured to the drain pan with a screw-down clamp (see Figure 18). The second switch (electronic/conductance) is located in the control panel with the sensor mounted adjacent to the left outdoor coil in the outdoor drain pan (see Figure 19).

The float type switch in the indoor drain pan is equipped with an LED light that indicates when an overflow condition is present.

Electrically, the two condensate switches are wired in series with the unit's high pressure switch. All three switches have normally closed contacts, but if any of them are activated, it will then activate initially a

soft lockout of the compressor circuit. If recurrence happens on the same cooling call cycle, a hard lockout of the compressor circuit will occur.

The electronic switch for the outdoor drain pan has three LED lights giving a status update (see Figure 20).

To test the electronic overflow switch function, bridge across the probes with a wet finger. The unit should stop, and the RED LED should come on. Remove the finger from the probe. After approximately 5 seconds, the RED LED should go off and the GREEN and AMBER LEDs should come on.

To Reset (Clear AMBER LED):

Bridge across the sensor probes with wet finger until the RED LED comes on, then remove the bridge quickly. While the RED LED is still on, bridge the probes again quickly (within 2 seconds). Hold until the AMBER LED goes off, then immediately remove the bridge.

**FIGURE 18**  
Indoor Condensate Overflow Switch



**FIGURE 19**  
Outdoor Condensate Sensor

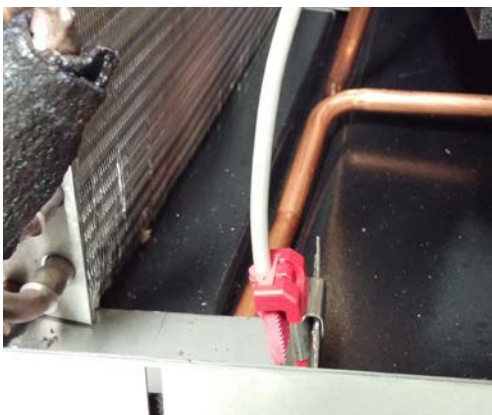

**FIGURE 20**  
Outdoor Condensate Control



**RED LED Illuminated:**  
Overflow currently being detected,  
switch activated

**GREEN LED Illuminated:**  
No overflow currently being  
detected

**AMBER LED Illuminated:**  
Previous condition detected

## Troubleshooting ECM™ 142R Outdoor Fan Motors

**WARNING**

- EXPOSED MOVING PARTS.
- DISCONNECT ALL ELECTRICAL POWER BEFORE SERVICING.
- FAILURE TO DO SO CAN RESULT IN SEVERE INJURY OR AMPUTATION.

**WARNING**

- HAZARD OF ELECTRICAL SHOCK.
- ELECTRICAL SHOCK CAN RESULT IN SERIOUS INJURY OR DEATH.
- DISCONNECT THE REMOTE ELECTRIC POWER SUPPLY OR SUPPLIES BEFORE SERVICING.

7961-755-1

1. In normal operation, this motor may rock back and forth on start up. Do not replace if this is the only symptom identified.
2. If the system is operating properly, but the motor appears to run slower than it should, the motor is good. High efficiency systems with optimized fan blades are engineered to run slow to decrease noise. The Bard I-TEC Series models also adjust fan speed based upon varied outdoor ambient conditions to optimize sound and unit efficiency.
3. If the system is noisy, freezing up, running a high head pressure, tripping the high pressure switch or compressor overload, check the following:
  - a. Ensure cleanliness of condenser coil(s) and fan blade/shroud.
  - b. Confirm the fan blade is not bent or deformed, isn't rubbing on the shroud and that it is tight on the motor shaft. Also ensure the motor is secure in its mounting system, and the mounting system is secure to the unit.
  - c. The Bard I-TEC is equipped with a low ambient control pressure switch. This pressure switch completes the 24VAC Common feed to the outdoor fan motor control in cooling mode. If this switch is defective, the outdoor air temperature is too cold to raise the head pressure to the 325# switch closing set-point or the system charge is too low, this could be the cause of the issue. (In heat pump {heating} mode, the low ambient fan cycling control is bypassed.)

### ⚠ CAUTION

**Do not operate motor without fan blade attached. Such operations will cause the motor to oscillate up and down.**

### ⚠ CAUTION

**The correct replacement motor from the manufacturer that is a direct replacement for the failed motor must be obtained.**

**USING THE WRONG MOTOR VOIDS ALL WARRANTIES AND MAY PRODUCE UNEXPECTED RESULTS.**

- d. If motor is not running, go to next section.
4. If the motor does not appear to be running at the proper speed or does not shut off, refer to the next section for voltage checks to determine if the motor is getting the proper input signals.

If the motor IS NOT receiving any communication, troubleshoot the communication issue using the diagnostic table for the fan logic control.

- a. This motor uses a 7 wire harness to control the motor.
  - Line power is connected as follows:
    - Red wire connects to "L1"
    - Black wire connects to "L2"
    - Green/yellow wire connects to ground
  - Control power is connected as follows:
    - Blue wire connects to fan relay of the defrost logic control, and subsequently connects to 24VAC common through the fan logic control board. Yellow wire connects to "Y" on the fan logic control board. White wire connects to "W" on the fan logic control board. Orange wire connects to "O" on the fan logic control board.

**NOTE:** A combination of the yellow, white and orange wires being energized (with 24V "R" signal) determines the five different speeds the fan motor will operate at. The fan logic control board uses an outdoor thermistor sensor to determine the speed the fan should operate. It also utilizes the "B" reversing valve input for heat pump mode to determine speed should operate.

**TABLE 7  
Troubleshooting ECM™ 142R Outdoor Fan Motor**

Check Line Power to Motor	Check between Red and Black Wires for Line Power
	Verify Ground by checking Green Wire to L1 and L2 Line Power
Check for 24VAC common signal to motor (against Transformer "R" Signal)	Check "BR" terminal of Fan Logic Control Board
	Check "Blue" Fan Lead on "Fan Relay Terminal" of "Defrost Logic Control"
	** Is not energized in cooling mode until Low Ambient Fan Cycling Control is closed by 325 PSIG refrigerant pressure. Above 65°F outdoors in cooling mode, the low ambient control is bypassed.
	** Circuit is completed automatically when "B" is energized on the Fan Logic Control Board
Check 24VAC "hot" outputs (to "Blue" on Fan Logic Control) to motor. See the following tables based upon outdoor temperature and model of operation.	

**Troubleshooting Fan Logic Control**

Please reference the Thermistor Temperature/Resistance Chart on page 34 (Table 6).

- GREEN STATUS LED – Blinks indicating there is a call for fan operation (simultaneous to call for compressor operation) and is normal.
- RED STATUS LIGHT (LA) – Is illuminated when low ambient control switch is in the closed position. *(NOTE: This is not required in heat pump operation as the low ambient switch is bypassed in this mode of operation. Low ambient switch is also negated in cooling mode above 65°F outdoor temperature.)*
- YELLOW STATUS LIGHT (B) – Is illuminated when there is a reversing valve call (for heat pump operation). *(NOTE: As mentioned above, this mode*

*of operation negates the low ambient fan cycling control.)*

If the board is reading a fan temperature thermistor value of 3375Ω or less (equivalent to 125°F or an "open" sensor), the fan will operate at the highest speed setting (energizes "W" and "Y" outputs on the board).

If the board is reading a fan temperature value of 118,110Ω or greater (equivalent to -10°F or a "shorted" sensor), the fan will operate at the highest speed setting (energizes "W" and "Y" outputs on the board).

If the low ambient switch is open, the red light will not be illuminated and the "BR" terminal will show open. The "BR" terminal is the "24 volt common" switching output to the outdoor fan motor.

**TABLE 8  
Cooling Mode**

O.D. Temp Sensor	24VAC Signals Between
Below 55°F	Orange to Blue
Between 56° - 69°F	White to Blue
Between 70° - 85°F	Yellow to Blue
Between 86° - 112°F	Orange and White to Blue
Above 112°F	White and Yellow to Blue

**TABLE 9  
Heat Pump Mode**

O.D. Temp Sensor	24VAC Signals Between
Above 56°F	Orange to Blue
Between 55° - 30°F	White to Blue
Between 29° - 14°F	Yellow to Blue
Below 13°F	Orange and White to Blue

*If the output signals are not matching the specified temperature range, go to Table 6 on page 34 and verify the thermistor output curve. If the motor is receiving proper communications and proper high voltage power, and is still not running, proceed with motor replacement.*

**Replacing the Motor**

This motor is replaced in one piece. The control cannot be replaced separately from the motor. Even if the control is remotely located, the replacement part will be a new control with harness and new motor.

The correct replacement motor from the manufacturer that is a direct replacement for the failed motor must be used.

**Using the wrong motor voids all product warranties and may produce unexpected results.**

Always mount the replacement motor and control according to the manufacturers specifications using all required hardware to reduce vibration. Make sure all wires are free of the fan blade and not pinched in mountings or cabinet through points.

# Troubleshooting ECM™ Indoor Blower Motors

## CAUTION:

Disconnect power from unit before removing or replacing connectors, or servicing motor. To avoid electric shock from the motor's capacitors, disconnect power and wait at least 5 minutes before opening motor.

### Symptom

**Motor rocks slightly when starting**

**Motor won't start**

- No movement

- Motor rocks, but won't start

**Motor oscillates up & down while being tested off of blower**

**Motor starts, but runs erratically**

- Varies up and down or intermittent

- "Hunts" or "puffs" at high CFM (speed)

- Stays at low CFM despite system call for cool or heat CFM

- Stays at high CFM

- Blower won't shut off

**Excessive noise**

- Air noise

### Cause/Procedure

- This is normal start-up for ECM

- Check blower turns by hand
- Check power at motor
- Check low voltage (24 Vac R to C) at motor
- Check low voltage connections (G, Y, W, R, C) at motor
- Check for unseated pins in connectors on motor harness
- Test with a temporary jumper between R - G
- Check motor for tight shaft
- Perform motor/control replacement check
- **Perform Moisture Check**

- Check for loose or compliant motor mount
- Make sure blower wheel is tight on shaft
- Perform motor/control replacement check

- It is normal for motor to oscillate with no load on shaft

- Check line voltage for variation or "sag"
- Check low voltage connections (G, Y, W, R, C) at motor, unseated pins in motor harness connectors
- Check "Bk" for erratic CFM command (in variable-speed applications)
- Check out system controls, Thermostat
- Perform Moisture Check

- Does removing panel or filter reduce "puffing"?
  - Reduce restriction
  - Reduce max airflow

- Check low voltage (Thermostat) wires and connections
- Verify fan is not in delay mode; wait until delay complete
- "R" missing/not connected at motor
- Perform motor/control replacement check

- "R" missing/not connected at motor
- Is fan in delay mode? - wait until delay time complete
- Perform motor/control replacement check

- Current leakage from controls into G, Y or W?
  - Check for Triac switched thermostat or solid-state relay

- Determine if it's air noise, cabinet, duct or motor noise; interview customer, if necessary
- High static creating high blower speed?
  - Is airflow set properly?
  - Does removing filter cause blower to slow down? Check filter
  - Use low-pressure drop filter
  - Check/correct duct restrictions

### Symptom

- Noisy blower or cabinet

- "Hunts" or "puffs" at high CFM (speed)

### Evidence of Moisture

- Motor failure or malfunction has occurred and moisture is present
- Evidence of moisture present inside air mover

### Do

- Check out motor, controls, wiring and connections thoroughly before replacing motor
- Orient connectors down so water can't get in
  - Install "drip loops"
- Use authorized motor and model #'s for replacement
- Keep static pressure to a minimum:
  - Recommend high efficiency, low static filters
  - Recommend keeping filters clean.
  - Design ductwork for min. static, max. comfort
  - Look for and recommend ductwork improvement, where necessary

- Size the equipment wisely

- Check orientation before inserting motor connectors

### Moisture Check

- Connectors are oriented "down" (or as recommended by equipment manufacturer)
- Arrange harness with "drip loop" under motor
- Is condensate drain plugged?
- Check for low airflow (too much latent capacity)
- Check for undercharged condition
- Check and plug leaks in return ducts, cabinet

### Comfort Check

- Check proper airflow settings
- Low static pressure for lowest noise
- Set low continuous-fan CFM
- Use humidistat and 2-speed cooling units
- Use zoning controls designed for ECM that regulate CFM
- Thermostat in bad location?

### Cause/Procedure

- Check for loose blower housing, panels, etc.
- High static creating high blower speed?
  - Check for air whistling through seams in ducts, cabinets or panels
  - Check for cabinet/duct deformation

- Does removing panel or filter reduce "puffing"?
  - Reduce restriction
  - Reduce max. airflow

- Replace motor and **Perform Moisture Check**

- **Perform Moisture Check**

### Don't

- Automatically assume the motor is bad.

- Locate connectors above 7 and 4 o'clock positions

- Replace one motor or control model # with another (unless an authorized replacement)
- Use high pressure drop filters; some have ½" H2O drop!
- Use restricted returns

- Oversize system, then compensate with low airflow

- Plug in power connector backwards
- Force plugs

## Replacing ECM Control Module

To replace the control module for the GE variable-speed indoor blower motor, take the following steps:

1. Have the correct replacement module. The controls are factory programmed for specific operating modes. Even though they look alike, different modules may have completely different functionality.  
**USING THE WRONG CONTROL MODULE VOIDS ALL PRODUCT WARRANTIES AND MAY PRODUCE UNEXPECTED RESULTS.**
2. Begin by removing AC power from the unit being serviced. **DO NOT WORK ON THE MOTOR WITH AC POWER APPLIED.** To avoid electric shock from the motor's capacitors, disconnect power and wait at least 5 minutes before opening motor.
3. It is not necessary to remove the motor from the blower assembly, nor the blower assembly from the unit. Unplug the two cable connectors to the motor control assembly. There are latches on each connector. **DO NOT PULL ON THE WIRES.** The plugs remove easily when properly released.
4. Locate the screws that retain to the motor control bracket to the sheet metal of the unit and remove them. Remove two (2) nuts that retain the control to the bracket and then remove two (2) nuts that retain sheet metal motor control end plate. Refer to Figure 21.
5. Disconnect the three (3) wires interior of the motor control using thumb and forefinger to squeeze the latch tab and the opposite side of the connector plug, gently pulling the connector. **DO NOT PULL ON THE WIRES, GRIP THE PLUG ONLY.** Refer to Figure 21.
6. The control module is now completely detached from the motor. Verify with a standard ohmmeter that the resistance from each motor lead (in the motor plug just removed) to the motor shell is >100K ohms. Refer to Figure 22. (Measure to unpainted motor end plate.) If any motor lead fails this test, do not proceed to install the control module. **THE MOTOR IS DEFECTIVE AND MUST BE REPLACED.** Installing the new control module will cause it to fail also.

7. Verify that the replacement control is correct for the application. Refer to the manufacturer's authorized replacement list. **USING THE WRONG CONTROL WILL RESULT IN IMPROPER OR NO BLOWER OPERATION.** Orient the control module so that the 3-wire motor plug can be inserted into the socket in the control. Carefully insert the plug and press it into the socket until it latches. **A SLIGHT CLICK WILL BE HEARD WHEN PROPERLY INSERTED.**
8. Reverse Steps #5, 4, 3 to reconnect the motor control to the motor wires, secure the motor control cover plate, mount the control to the bracket and mount the motor control bracket back into the unit. **MAKE SURE THE ORIENTATION SELECTED FOR REPLACING THE CONTROL ASSURES THE CONTROL'S CABLE CONNECTORS WILL BE LOCATED DOWNWARD IN THE APPLICATION SO THAT WATER CANNOT RUN DOWN THE CABLES AND INTO THE CONTROL. DO NOT OVERTIGHTEN THE BOLTS.**
9. Plug the 16-pin control plug into the motor. The plug is keyed. Make sure the connector is properly seated and latched.
10. Plug the 5-pin power connector into the motor. Even though the plug is keyed, **OBSERVE THE PROPER ORIENTATION. DO NOT FORCE THE CONNECTOR.** It plugs in very easily when properly oriented. **REVERSING THIS PLUG WILL CAUSE IMMEDIATE FAILURE OF THE CONTROL MODULE.**
11. Final installation check. Make sure the motor is installed as follows:
  - a. Motor connectors should be oriented between the 4 o'clock and 8 o'clock positions when the control is positioned in its final location and orientation.
  - b. Add a drip loop to the cables so that water cannot enter the motor by draining down the cables. Refer to Figure 23.

The installation is now complete. Reapply the AC power to the HVAC equipment and verify that the new motor control module is working properly. Follow the manufacturer's procedures for disposition of the old control module.

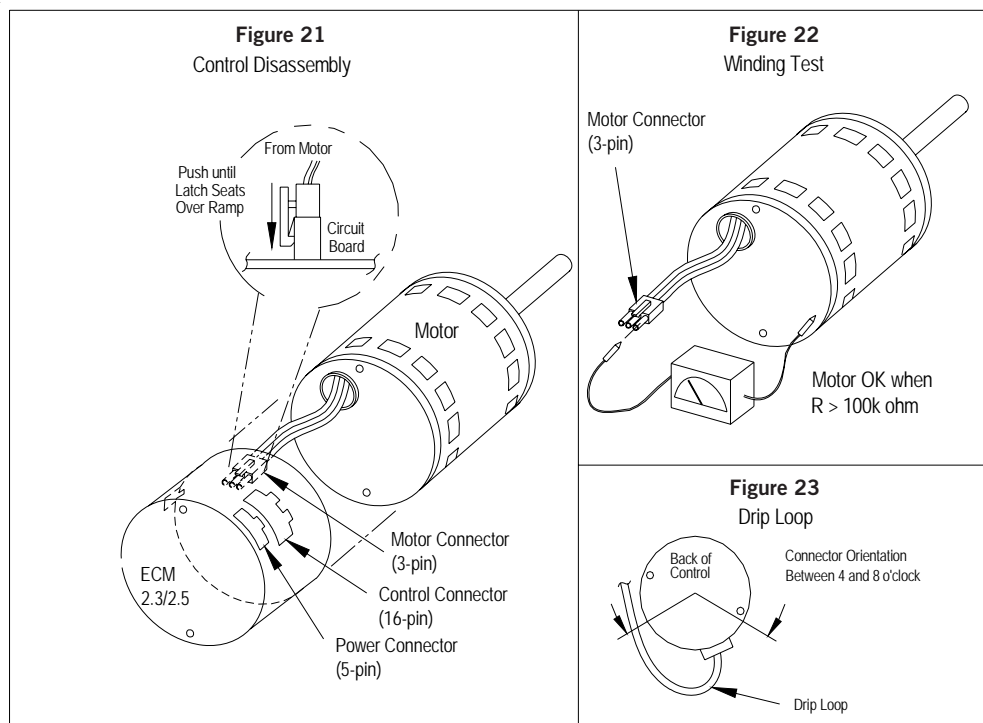

## Troubleshooting ECM™ Indoor Blower Motors

MODE of OPERATION	OFF	Continuous Blower (Ventilation Mode)	Part Load Cooling	Full Load Cooling	Dehum. Mode (when equipped)	Part Load Heat Pump	Full Load Heat Pump	Heat Pump Full Load w/ 1st Bank of Elec. Heat	Heat Pump Full Load w/ 1st & 2nd Bank of Elec. Heat	Emergency Heat Mode
Thermostat 24 VAC Input Signals	—	"G"	"G", "Y1", "Y2"	"G", "Y1", "Y2"	"D"	"G", "B", "Y1"	"G", "B", "Y1", "Y2"	"G", "Y1", "Y2", "B", "W1"	"G", "Y1", "Y2", "B", "W2", "W3"	"G", "W2", "W3"
Pin #1	24 VAC "C" (Common) Signal, Always Energized									
Pin #2								X		
Pin #3	24 VAC "C" (Common) Signal, Always Energized									
Pin #4	Not Used									
Pin #5	Not Used									
Pin #6			X	X	X	X	X	X	X	
Pin #7	Not Used									
Pin #8	Not Used									
Pin #9						X	X	X		
Pin #10	Not Used									
Pin #11	Not Used									
Pin #12	24 VAC Hot "R" Signal, Always Energized									
Pin #13									X	X
Pin #14				X	X	X		X	X	
Pin #15		X	X	X	X	X	X	X	X	X
Pin #16	Not Used									

**FIGURE 24 – Control Connector Motor Half**

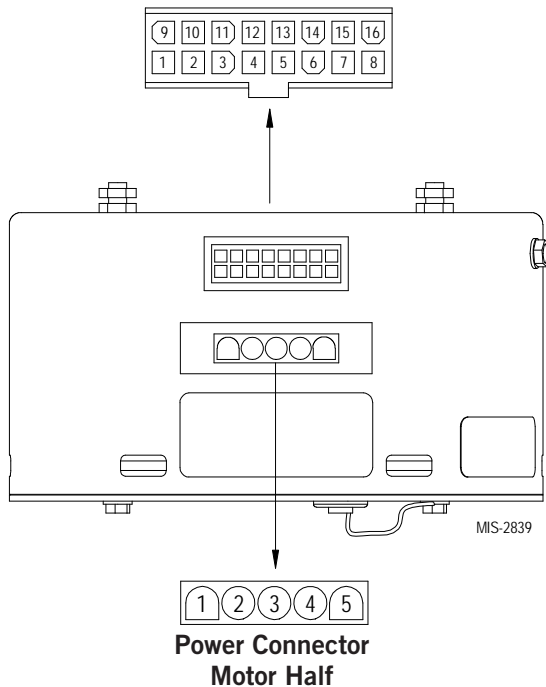

POWER CONNECTOR	
PWB HEADER	AMP 1-350945-0
PIN	Description
1	Jumper Pin 1 to Pin 2 for 120VAC Line Input Only **
2	
3	Chassis Ground
4	AC Line
5	AC Line

\* Suggested mating connector  
Housing – AMP 350809-1  
Contact – AMP 350537-1

\*\* **WARNING: Applying 240VAC line input with PIN 1 to PIN 2 jumper in place will permanently damage unit!**

## Fan Blade Setting Dimensions

The position of the fan blade should be set at 2.75", measuring from the motor mount to the closest point on the fan blade (as shown in Figure 25). Spin the blade by hand to make sure it does not hit the ring.

**FIGURE 25**  
**Fan Blade Position**

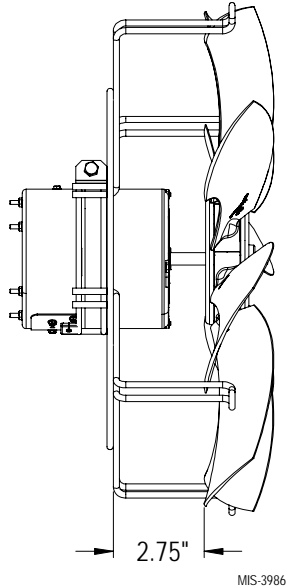

## Refrigerant Charge

This unit was charged at the factory with the quantity of refrigerant listed on the serial plate. AHRI capacity and efficiency ratings were determined by testing with this refrigerant charge quantity. The pressure tables on page 42 show nominal pressures and temperatures for the units. Since many installation specific situations can affect the pressure readings, this information should only be used by certified technicians as a guide for evaluating proper system performance. They shall not be used to adjust charge. If charge is in doubt, reclaim, evacuate and recharge the unit to the serial plate charge.

**TABLE 10A – Full Load Cooling Pressure/Temperature**

Model	Return Air Temp.	Pressure	55°	60°	65°	70°	75°	80°	85°	90°	95°	100°	105°	110°	115°	120°	125°
I36Z1	75° DB 62° WB	Low Side	126	127	129	130	131	132	134	135	136	137	138	139	140	141	141
		High Side	209	231	252	274	295	317	338	360	381	407	433	458	484	510	536
	80° DB 67° WB	Low Side	137	139	141	142	144	148	149	150	151	152	153	154	155	156	157
		High Side	219	239	260	280	300	314	341	359	381	407	433	458	484	510	535
	85° DB 72° WB	Low Side	154	155	157	158	159	160	162	163	164	165	166	167	168	169	171
		High Side	217	240	262	285	307	330	352	375	397	424	451	477	504	531	540
I48Z1	75° DB 62° WB	Low Side	118	121	124	126	129	131	134	136	139	140	141	142	143	144	145
		High Side	221	239	257	275	293	311	329	347	365	397	430	462	494	527	559
	80° DB 67° WB	Low Side	132	134	137	139	141	141	144	148	151	152	154	155	156	157	159
		High Side	223	242	261	280	299	348	373	366	375	408	442	475	508	541	575
	85° DB 72° WB	Low Side	140	144	147	151	154	158	161	165	168	170	171	173	174	175	177
		High Side	234	253	271	289	307	326	344	362	380	414	448	482	515	549	583
I60Z1	75° DB 62° WB	Low Side	123	124	124	125	126	127	128	129	129	131	132	134	135	136	138
		High Side	218	241	265	289	312	336	360	383	407	431	456	481	505	530	554
	80° DB 67° WB	Low Side	137	137	138	138	139	140	140	141	141	143	144	146	147	149	150
		High Side	219	244	269	294	319	341	375	392	418	443	469	494	519	544	570
	85° DB 72° WB	Low Side	146	147	148	150	151	153	154	156	157	159	161	162	164	166	167
		High Side	231	255	279	303	327	352	376	400	424	450	475	501	527	552	578

**TABLE 10B – Full Load Heating Pressure/Temperature**

Model	Return Air Temp.	Pressure	0°	5°	10°	15°	20°	25°	30°	35°	40°	45°	50°	55°	60°	65°	70°
I36Z1	70° DB	Low Side	38	45	51	57	63	70	76	82	92	101	107	114	120	127	133
		High Side	317	319	320	322	324	326	327	329	356	382	388	395	401	408	414
I48Z1	70° DB	Low Side	33	40	47	54	60	67	74	81	89	97	106	114	122	130	138
		High Side	268	276	285	293	301	309	318	326	334	342	349	356	363	370	377
I60Z1	70° DB	Low Side	38	42	46	50	54	58	63	67	80	94	100	107	114	120	127
		High Side	285	289	293	297	301	305	309	313	335	357	365	372	380	387	395

**TABLE 11A  
Part Load Cooling Pressure/Temperature**

Model	Return Air Temp.	Pressure	55°	60°	65°	70°	75°	80°	85°	90°	95°	100°	105°	110°	115°	120°	125°
I36Z1	75° DB 62° WB	Low Side	131	133	134	136	137	139	140	142	143	144	145	146	148	149	150
		High Side	188	209	230	250	271	292	313	333	354	379	403	428	453	478	502
	80° DB 67° WB	Low Side	145	146	148	149	150	154	154	155	155	156	158	159	160	161	163
		High Side	192	213	234	254	275	292	320	336	358	383	408	433	458	483	508
	85° DB 72° WB	Low Side	158	159	161	162	163	164	166	167	168	169	171	172	173	175	176
		High Side	198	219	240	260	281	302	323	343	364	389	415	440	466	491	517
I48Z1	75° DB 62° WB	Low Side	126	127	129	130	131	133	134	135	137	138	139	140	141	142	144
		High Side	172	196	221	245	269	294	318	343	367	390	414	438	461	485	508
	80° DB 67° WB	Low Side	137	139	141	142	144	147	148	150	151	152	154	155	156	157	159
		High Side	171	197	222	248	274	312	346	355	377	401	426	450	474	498	523
	85° DB 72° WB	Low Side	150	152	154	156	158	160	162	164	166	167	168	170	171	173	174
		High Side	177	203	229	254	280	305	331	357	382	407	431	456	481	505	530
I60Z1	75° DB 62° WB	Low Side	127	127	128	128	129	130	130	131	131	133	134	136	138	139	141
		High Side	196	218	240	261	283	305	326	348	370	394	418	443	467	491	515
	80° DB 67° WB	Low Side	138	139	140	141	142	143	144	144	145	147	149	150	152	154	156
		High Side	196	219	242	265	288	316	347	359	380	405	430	455	480	505	530
	85° DB 72° WB	Low Side	152	153	153	154	155	156	157	158	159	161	163	165	167	169	171
		High Side	203	226	249	271	294	317	340	363	385	411	436	461	487	512	537

**TABLE 11B  
Part Load Heating Pressure/Temperature**

Model	Return Air Temp.	Pressure	0°	5°	10°	15°	20°	25°	30°	35°	40°	45°	50°	55°	60°	65°	70°
I36Z1	70° DB	Low Side	45	51	57	63	69	75	81	87	94	100	110	119	129	138	148
		High Side	270	272	274	276	278	280	282	284	300	315	321	326	332	337	343
I48Z1	70° DB	Low Side	33	42	50	58	66	75	83	91	97	103	113	122	132	141	151
		High Side	261	267	272	278	284	290	295	301	311	320	330	340	350	360	370
I60Z1	70° DB	Low Side	37	44	52	59	67	74	82	89	97	104	111	119	126	134	141
		High Side	261	270	280	289	299	308	318	327	339	350	359	368	378	387	396

**Air Temperature Entering Outdoor Coil °F**