

---

# INSTALLATION INSTRUCTIONS

---

## COMMERCIAL ROOM VENTILATOR WITH PLUG-IN CONNECTIONS AND EXHAUST

Models:

WCRVPS2 WCRVPS3 WCRVPS5

For Use with Bard Single Stage Wall Mount Air  
Conditioner and Heat Pump Models:

WCRVPS2: W18A/L\*, W24A/L\*, W18H\*, W24H\*

WCRVPS3: W30A/L\*, W36A/L\*, W30H\*, W36H\*

WCRVPS5: W42A/L\*, W48A/L\*, W60A/L\*, W72A/L\*,  
W42H\*, W48H\*, W60H\*



*Climate Control Solutions*

Bard Manufacturing Company, Inc.  
Bryan, Ohio 43506  
[www.bardhvac.com](http://www.bardhvac.com)

Manual: 2100-638B  
Supersedes: 2100-638A  
Date: 9-19-16

# CONTENTS

---

## **General Information .....3**

Commercial Room Ventilator Model Nomenclature...	3
Unpacking .....	3
General .....	3
Description .....	3
Models .....	3

## **Installation of Field-Installed WCRVPS\* .....4**

Basic Installation.....	4
Control System Notes.....	9
Blade Adjustment for Desired Ventilation Air .....	14
Commercial Room Ventilator.....	17

## **Figures**

Figure 1	Wall Mount Unit Access Panels .....	4
Figure 2	Condenser Exhaust Plate with Screen.....	5
Figure 3	Filter Bracket and Filter Bracket Fill Plate Installation .....	6
Figure 4	Extension Cable Installation .....	7
Figure 5	Damper Assembly Installation .....	8
Figure 6	Vent Hood Assembly.....	8
Figure 7	CRV Control Board .....	10
Figure 8	Required Control Connections for CRV with Air Conditioners .....	11
Figure 9	Required Control Connections for CRV with Heat Pumps .....	12
Figure 10	CO <sub>2</sub> Sensor Default and Final Settings Bard Part #8403-067 CO <sub>2</sub> Controller ...	13
Figure 11	Call for Ventilation With or Without Compressor Operation .....	17
Figure 12	Call for Compressor or Fan Only with Ventilation Off .....	18

## **Graphs**

Graph 1	W18 and W24 Ventilation Delivery.....	14
Graph 2	W30 and W36 Ventilation Delivery.....	15
Graph 3	W42 and W48 Ventilation Delivery.....	15
Graph 4	W60 Ventilation Delivery.....	16
Graph 5	W72 Ventilation Delivery.....	16

**BARD MANUFACTURING COMPANY, INC.  
BRYAN, OHIO USA 43506**

# GENERAL INFORMATION

## COMMERCIAL ROOM VENTILATOR MODEL NOMENCLATURE

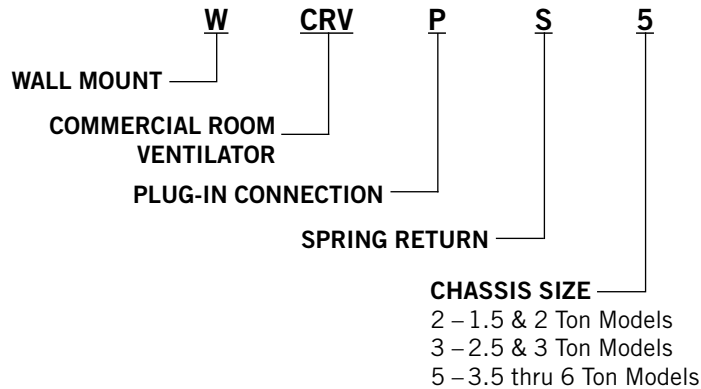

### UNPACKING

Upon receipt of the equipment be sure to compare the model number found on the shipping label with the accessory identification information on the ordering and shipping document to verify that the correct accessory has been shipped.

Inspect the carton housing of each ventilator as it is received, and before signing the freight bill, verify that all items have been received and that there is no visible damage. Note any shortages or damage on all copies of the freight bill. The receiving party must contact the last carrier immediately, preferably in writing, requesting inspection by the carrier's agent. Concealed damage not discovered until after loading must be reported to the carrier within 15 days of its receipt.

### GENERAL

The ventilator should only be installed by a trained heating and air conditioning technician. These instructions serve as a guide to the technician installing the ventilator package. They are not intended as a step-by-step procedure with which the mechanically inclined owner can install the package.

The ventilator housing is shipped in one carton which contains the electrical harness, miscellaneous hardware and installation instructions.

### DESCRIPTION

The WCRVPS\* ventilator is designed to be used with the specific models with "letter" revision codes as designated on the front page of this installation instructions manual.

The ventilator is an electromechanical vent system designed to provide fresh air to meet indoor air quality standards.

### MODELS

When installed in the models listed on the front page, the WCRVPS\* provides built-in exhaust provisions. When the damper blade opens to bring fresh air in, the damper also opens an exhaust relief. The exhaust air will flow into the condenser section of the unit. The condenser fan will help draw exhaust air out when it is operating with compressor in cooling or heat pump mode.

# INSTALLATION OF FIELD-INSTALLED WCRVPS\*

## BASIC INSTALLATION

### WARNING

**Electrical shock hazard.**

**Disconnect remote electrical power supply or supplies before servicing.**

**Failure to do so could result in electric shock or death.**

### Preparing Unit for WCRVPS\* Installation

1. Disconnect power to unit.
2. Unpack the WCRVPS\* assembly, which includes the integral controls and electrical harness, body panels, miscellaneous hardware and installation instructions.

3. From existing wall mount unit, remove and save (or discard) as directed (see Figure 1):
  - Ventilation option panel (discard)
  - Filter access panel (discard)
  - Filter (save)
  - Outer and inner control panel doors (save)
  - Filter tray (discard, if applicable)
4. Remove and discard the exhaust cover plate.
5. Install new condenser exhaust plate with screen over opening into condenser section (see Figure 2).
6. Remove filter brackets, if necessary. Two types of filter brackets have been used with these wall mount units. If the filter brackets are mounted flat, they can be used with the commercial room ventilator (CRV). If the brackets are set at a 30° angle, they must be removed and discarded. The circuit breaker offset plate must be loosened and moved slightly to gain access to several of the screws holding the filter brackets in place. Tighten the screws holding control panel after the filter brackets have been removed.

**FIGURE 1**  
**Wall Mount Unit Access Panels**

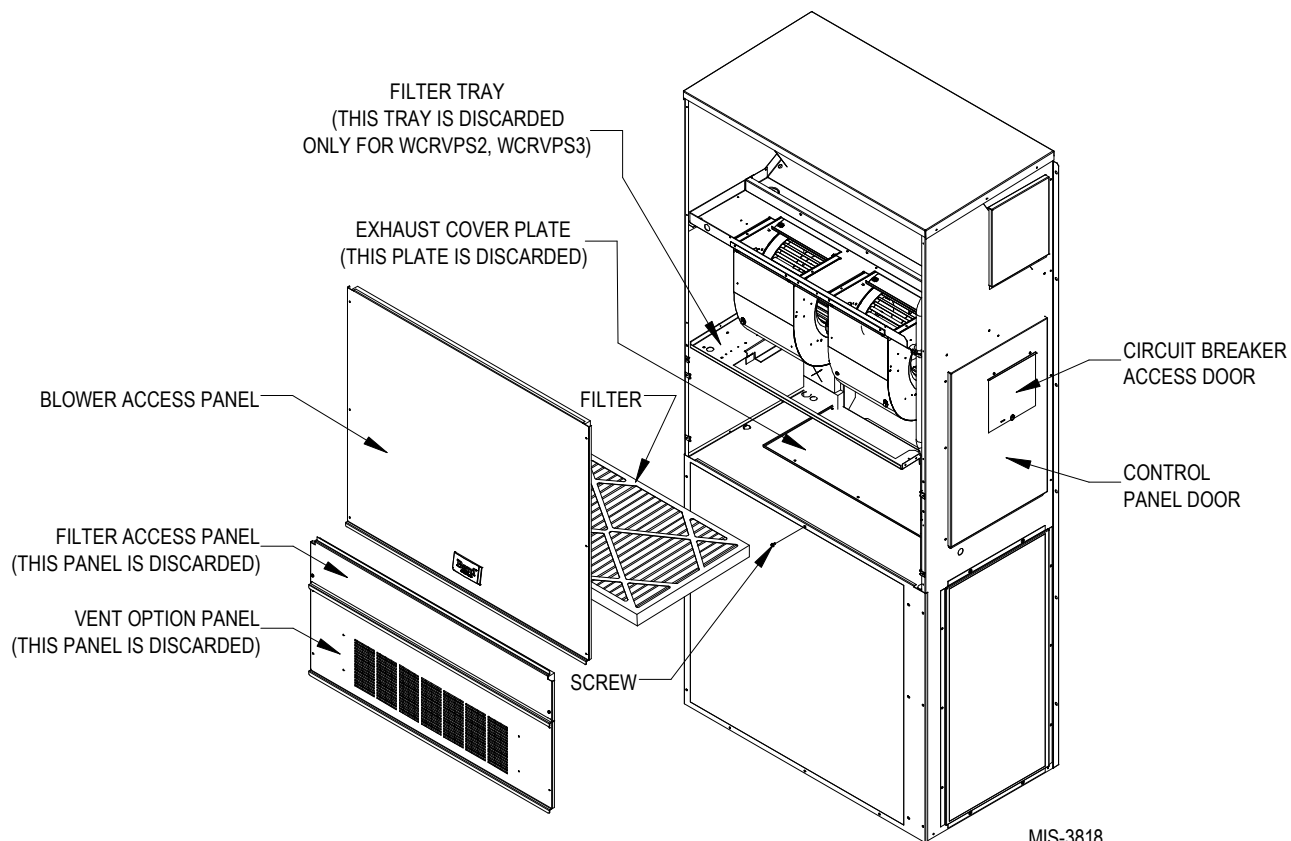

**FIGURE 2**  
**Condenser Exhaust Plate with Screen**

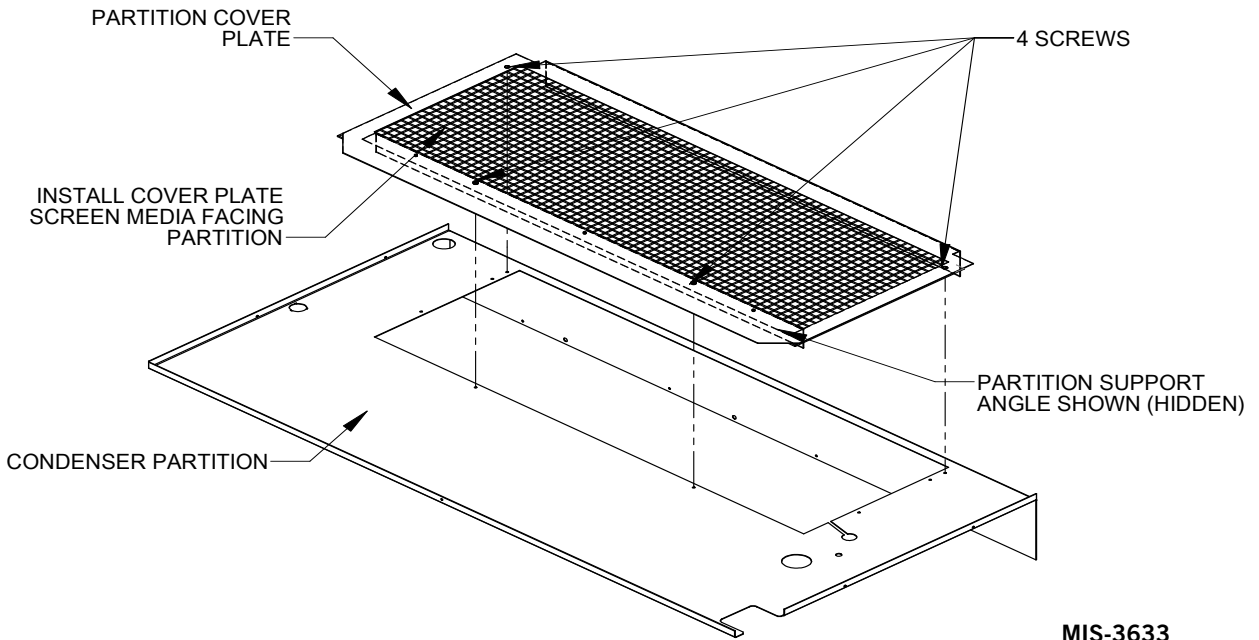

MIS-3633

If filter brackets were removed in Step 6, proceed to Step 7. If the brackets were not removed, proceed to **Commercial Room Ventilator (CRV) Installation** on page 7.

7. Install filter bracket fill plate (if applicable) as shown in Figure 3 on page 6.
8. Install provided filter brackets on WCRVPS\* assembly (see Figure 3).

**FIGURE 3**  
**Filter Bracket and Filter Bracket Fill Plate Installation**

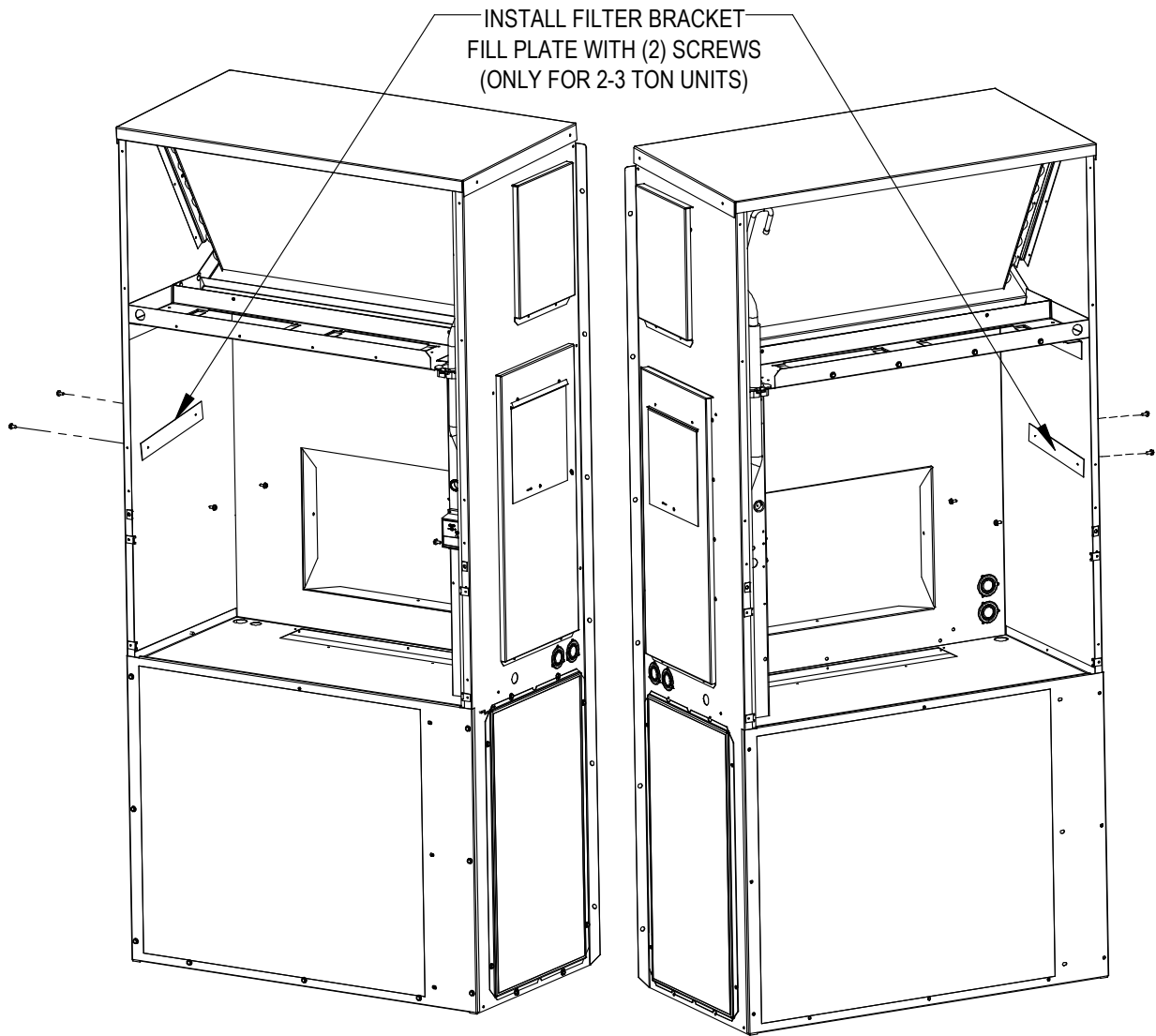

RIGHT HAND UNIT

LEFT HAND UNIT

LONG FILTER BRACKET (4) REGULAR SCREWS

(4) REGULAR SCREWS

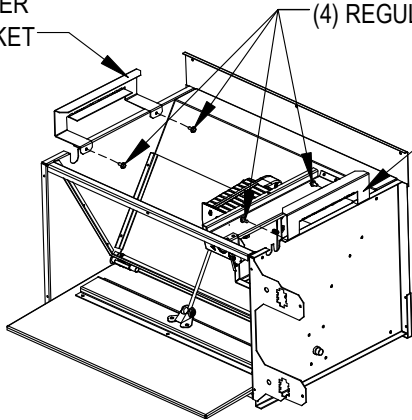

SHORT FILTER BRACKET

LONG FILTER BRACKET

RIGHT HAND VENT

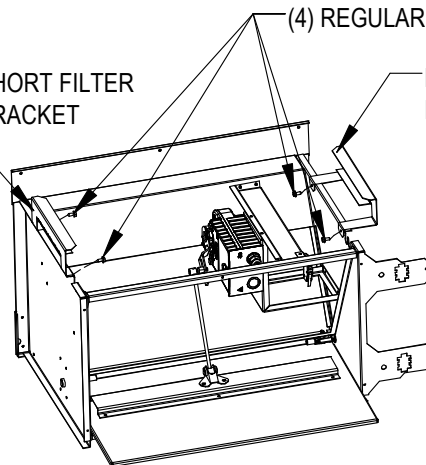

LEFT HAND VENT

MIS-3814

### Commercial Room Ventilator (CRV) Installation

1. Installed onto the WCRVPS\* are two 12-pin extension jumpers. One is 12" in length for right-hand models and the other is 72" in length for left-hand models. Lock the appropriate length jumper into the corresponding lower tab on the front of the ventilation package (see Figure 4).
2. Insert CRV into opening in the wall mount unit between the filter rack and the condenser section, being careful not to tear the unit insulation. Fully seat CRV assembly to rear of the cavity. Slide the CRV toward the control panel so that it lines up with the return air opening in the rear of the wall mount unit (see Figure 5 on page 8).
3. Insert and lock in the 12-pin extension cable installed in Step 1 into the front side of the control panel within the ventilation package section.
4. Replace the air filters if they were removed (airflow direction is up).
5. The next step involves installing the lower service panel, filter access cover and hood assembly that are included in the WCRVPS\* package. The front slotted vent hood cover and mist eliminator filter must be removed to access several mounted screws located behind them. Replace the mist eliminator and vent hood cover after the lower service panel, filter access cover and hood assembly have been installed (see Figure 6 on page 8).
6. Remove the vent control panel cover on the right-hand side of the vent hood.
7. Make all the required thermostat connections per the applicable connection diagram found on pages 11 or 12, and restore power to the unit.
8. Make any necessary changes required to the potentiometers to achieve the minimum continuous airflow and demand airflow desired.

**FIGURE 4**  
**Extension Cable Installation**

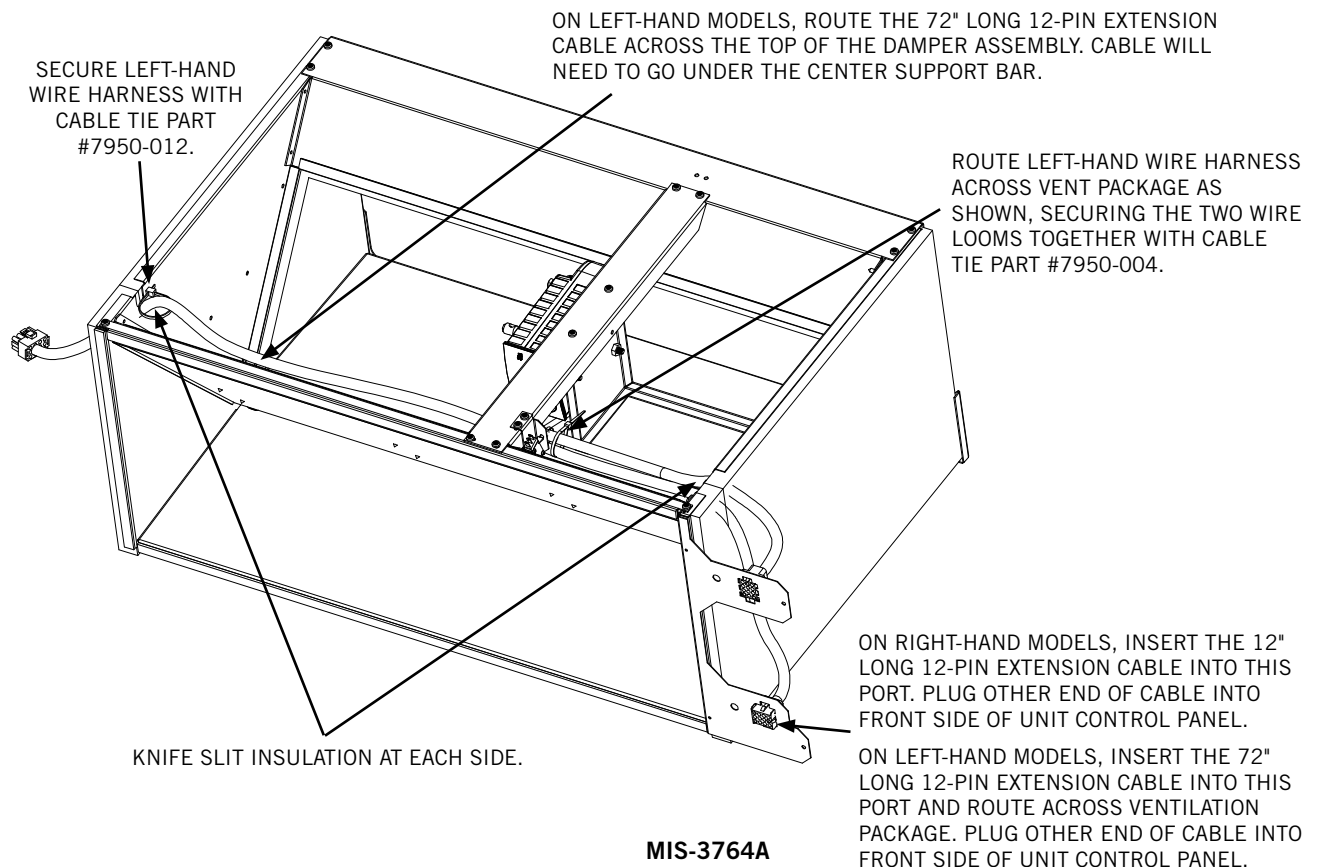

**FIGURE 5  
Damper Assembly Installation**

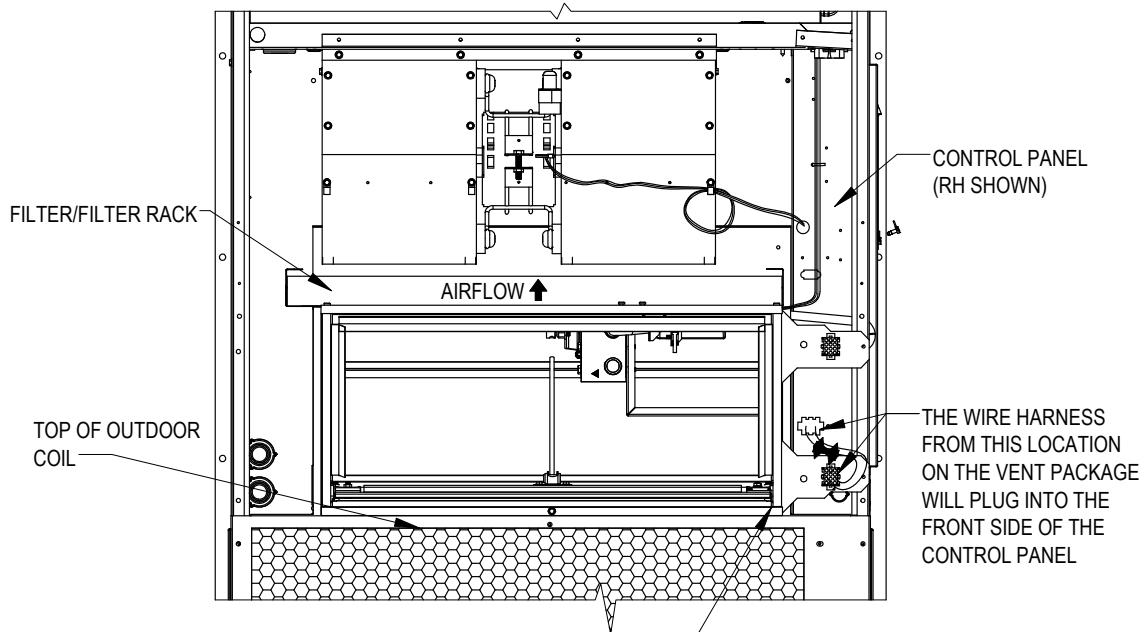

AFTER SLIDING THE VENT PACKAGE INTO THE WALL MOUNT, SLIDE IT TOWARD THE CONTROL PANEL SIDE ALIGNING IT WITH THE RETURN AIR OPENING IN THE REAR

MIS-3765

**FIGURE 6  
Vent Hood Assembly**

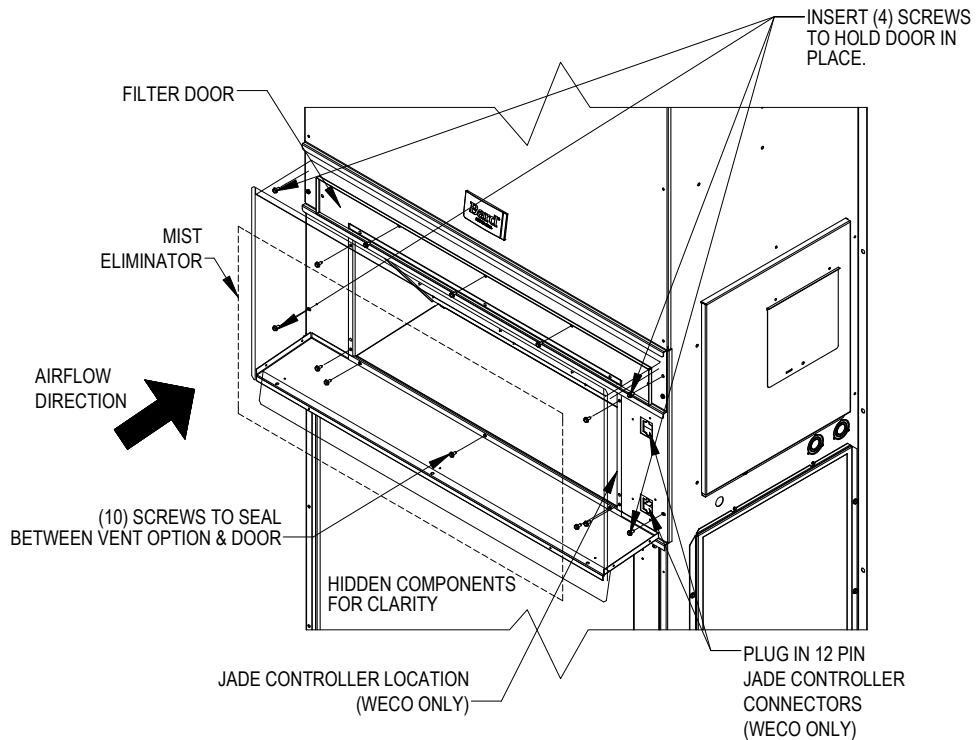

MIS-3635

## CO<sub>2</sub> Control

For CO<sub>2</sub>-based control, add a CO<sub>2</sub> sensor/controller (Bard part #8403-067) to the wall and run additional optional wires as shown in the wiring diagrams on pages 11 and 12.

The CO<sub>2</sub> controller must also be reconfigured from the standard default settings as shipped from the factory. See page 13 for complete details.

## Control System Notes

This ventilation package is set to meet the current ASHRAE specifications for minimum occupied airflow rates, with extended capability to meet demand ventilation requirements. There are two different provisions to optimize this control path. One is the utilization of switch closures (occupancy and CO<sub>2</sub> demand) and the other is the utilization of occupancy (switch closure) and modulating CO<sub>2</sub>.

### Two Switch Application

Energizing the A terminal in the low voltage connection box during occupied conditions will allow the minimum occupied airflow rate to be set to meet ASHRAE requirements. This can be accomplished by adjusting Potentiometer R1 on the CRV control board by aligning the damper position per the charts included on pages 14-16 (see Figure 7 on page 10). The factory default blade position for this condition is set to position 3.

Energizing Terminal 5 in the low voltage connection box will then drive the damper open to the CFM rate as set by Potentiometer R2 on the CRV control board (see Figure 7). Refer to the proper chart on pages 14-16 for the airflow to damper position correlation. The factory default blade position for this condition is set to position 4.5.

### Modulating CO<sub>2</sub> Control

Wire the R power wire of the CO<sub>2</sub> control to A of the low voltage terminal block, then energize A based upon occupancy.

Connect the brown/white wire that is landed on the PARK terminal in the CRV control board to the OCC terminal of the CRV control board.

Once things are powered up and the CO<sub>2</sub> control has equalized, adjust Potentiometer R7 to the minimum damper open position to yield the desired occupied airflow rates. The CO<sub>2</sub> control will then take over in modulating the damper position to maintain the proper CO<sub>2</sub> rates.

**FIGURE 7  
CRV Control Board**

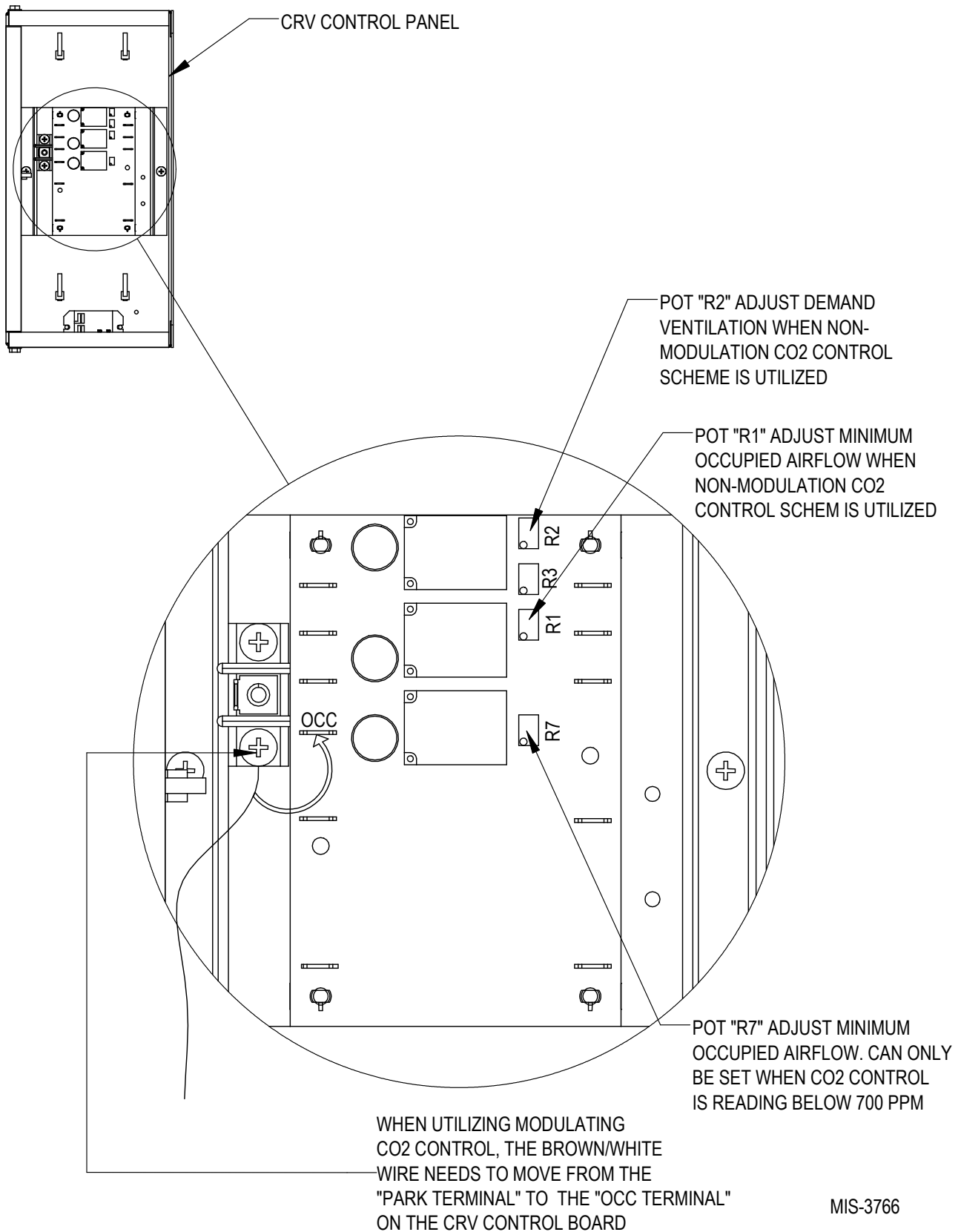

MIS-3766

**FIGURE 8**  
**Required Control Connections for CRV with Air Conditioners**

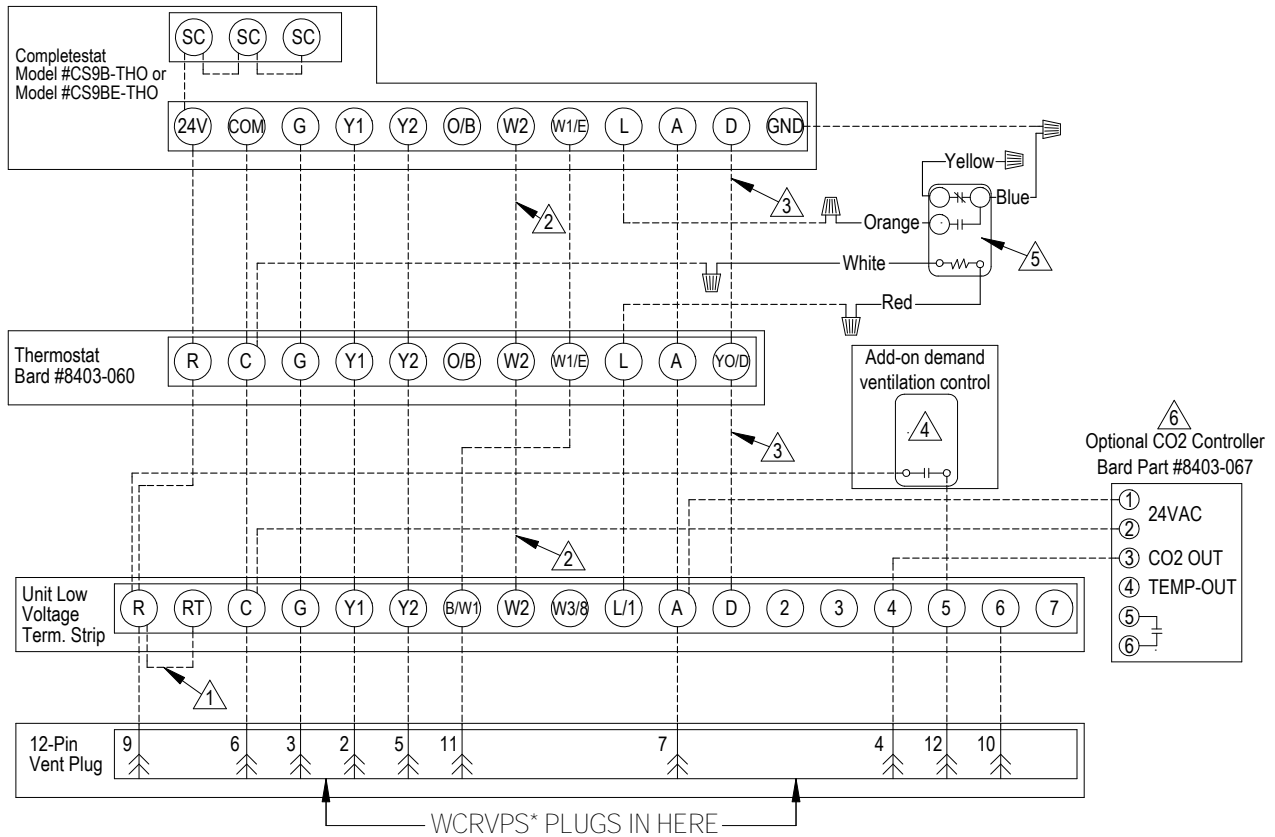

- ① Factory installed jumper. Remove jumper and connect to N.C fire alarm circuit if emergency shutdown required.
- ② Not needed below 15KW.
- ③ Additional wire required for dehumidification models.

- ④ Demand ventilation control, which could include switched CO2 control, or secondary motion activated switch. Would be negated with option 7 (CO2 with 0-10VDC modulating output)
- ⑤ Relay Provided with Completestat
- ⑥ 0-10 VDC Modulating CO2 control for modulating ventilation control

MIS-3726 A

**FIGURE 9**  
**Required Control Connections for CRV with Heat Pumps**

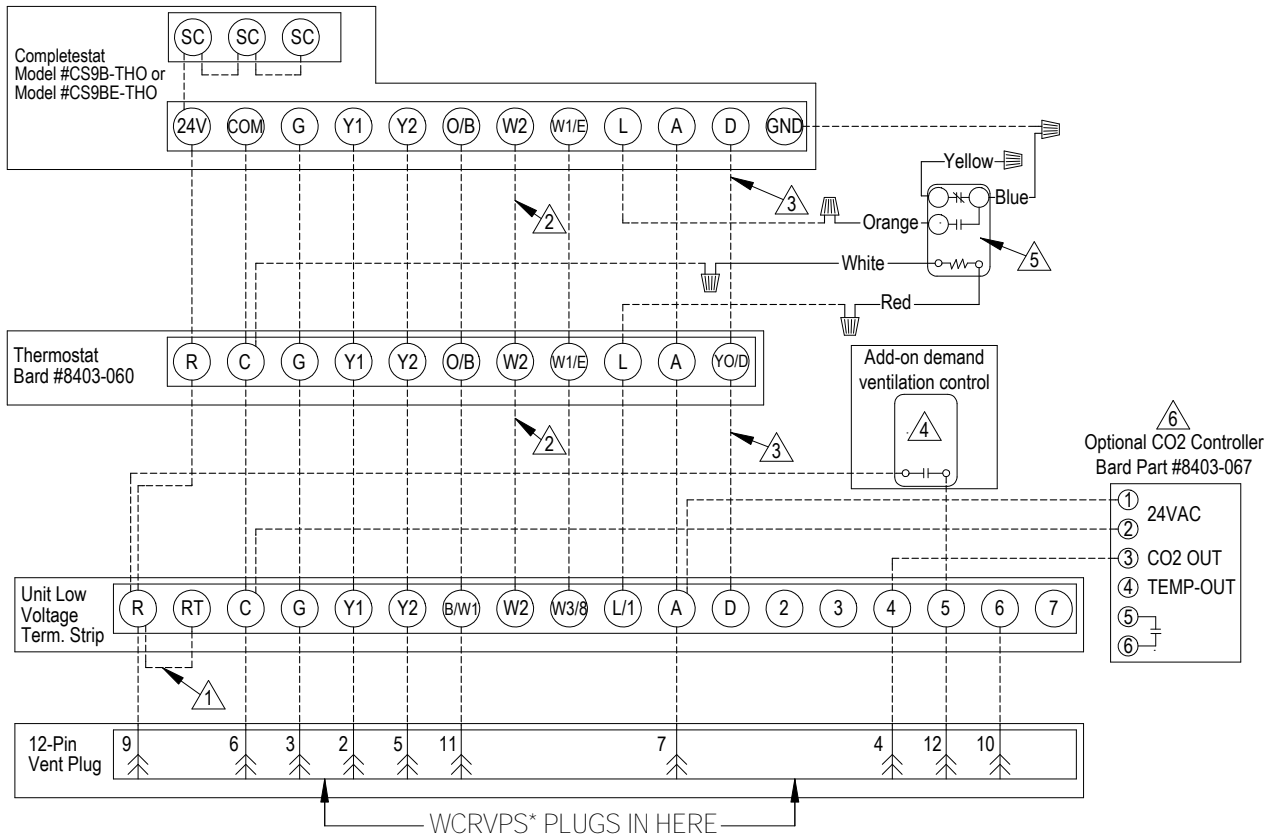

- ① Factory installed jumper. Remove jumper and connect to N.C fire alarm circuit if emergency shutdown required.
- ② Not needed below 15KW.
- ③ Additional wire required for dehumidification models.
- ④ Demand ventilation control, which could include switched CO2 control, or secondary motion activated switch. Would be negated with option 7 (CO2 with 0-10VDC modulating output)
- ⑤ Relay Provided with Completestat
- ⑥ 0-10 VDC Modulating CO2 control for modulating ventilation control

MIS-3727 A

**FIGURE 10**  
**CO<sub>2</sub> Sensor Default and Final Settings**  
**Bard Part #8403-067 CO<sub>2</sub> Controller**

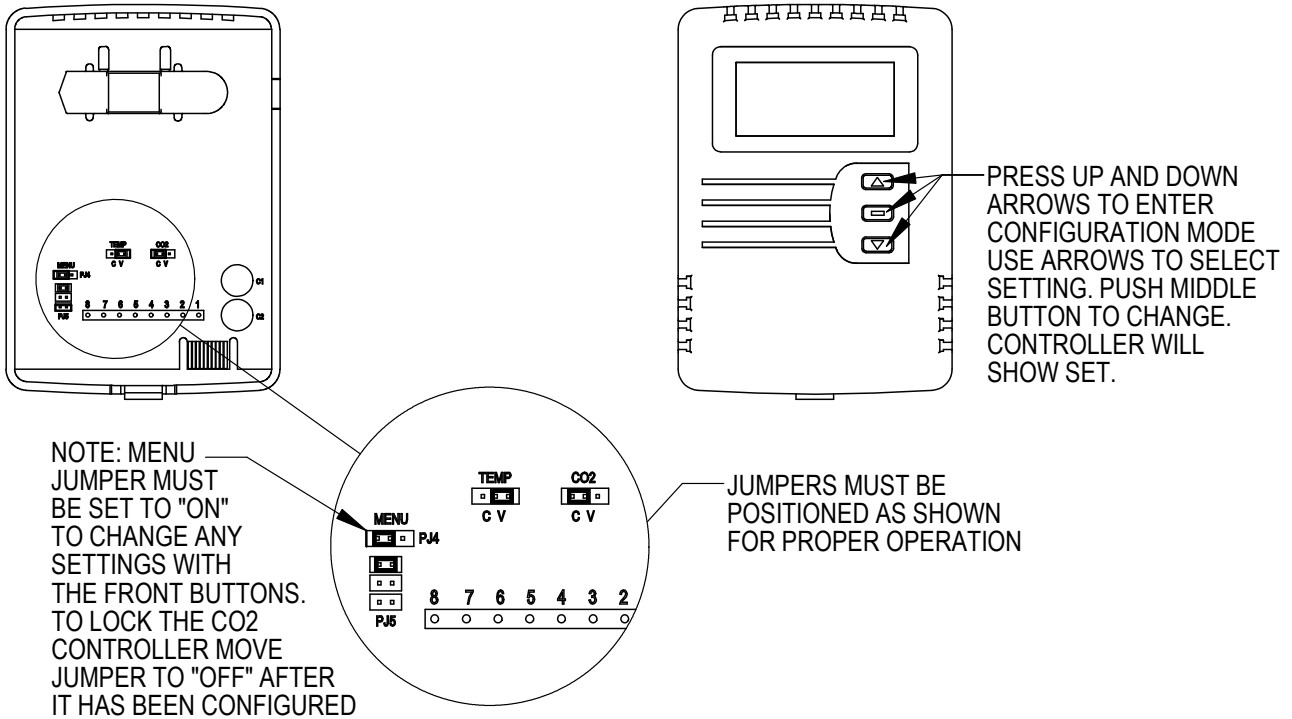

4-20mA	AN (ppm)	Damper (1)	Approx. Blade Position (2)
4	700	MIN. OCC. VENTILATION	0
5	750		.6
6	800		1.3
7	850		1.9
8	900		2.5
9	950		3.1
10	1000		3.8
11	1050		4.4
12	1100		5
13	1150		5.6
14	1200		6.3
15	1250		6.9
16	1300		7.5
17	1350		8.1
18	1400		8.8
19	1450		9.4
20	1500	FULLY OPEN	10

Settings	Recommended	Default
RON	Not Used	
ROF	Not Used	
DSP	C	CT
UNI	US	US
COL	700	0
COH	1500	2000
TOL	Not Used	
TOH	Not Used	
BAR	See Instrution with Controller For High Altitude Installations	
CAL	Used for Field Calibration	

(1) Damper should be at the required minimum occupied ventilation rate when the CO<sub>2</sub> control is at 700 ppm. Potentiometer R7 can be adjusted clockwise (CW) to close it down, or counter clockwise (CCW) to open it to the required setpoint.  
 (2) Blade as referenced to the Blade Position Label.

MIS-3763

## BLADE ADJUSTMENT FOR DESIRED VENTILATOR AIR

The amount of ventilation air supplied by the commercial room ventilator is dependant on four factors.

1. Return air duct static pressure drop.
2. Supply air duct static pressure drop.
3. Indoor blower motor speed.
4. Damper blade open position setting.

Refer to the appropriate graph below and on the following pages to determine the blade setting necessary to achieve the ventilation air required for each operating mode.

### Factory Default Settings

Potentiometer R1: 3

Potentiometer R2: 6

For more accurate adjustment, use a flowhood over the intake opening to measure and adjust the airflow operation.

Potentiometer R1 Adjusts the minimum constant airflow during occupied conditions

Potentiometer R2 Adjusts the airflow on a contact closure for demand ventilation

Energize occupied condition mode and adjust #1 Potentiometer to desired airflow.

Energize demand ventilation mode and adjust #2 Potentiometer to desired airflow.

Minimum damper position when using CO<sub>2</sub> control damper should be at minimum occupied airflow at 700 ppm or lower; if not, Potentiometer R7 can be adjusted clockwise (CW) to close it. If it is fully closed at 700 ppm or lower, no adjustments are required.

**GRAPH 1**  
**W18 and W24 Ventilation Delivery**

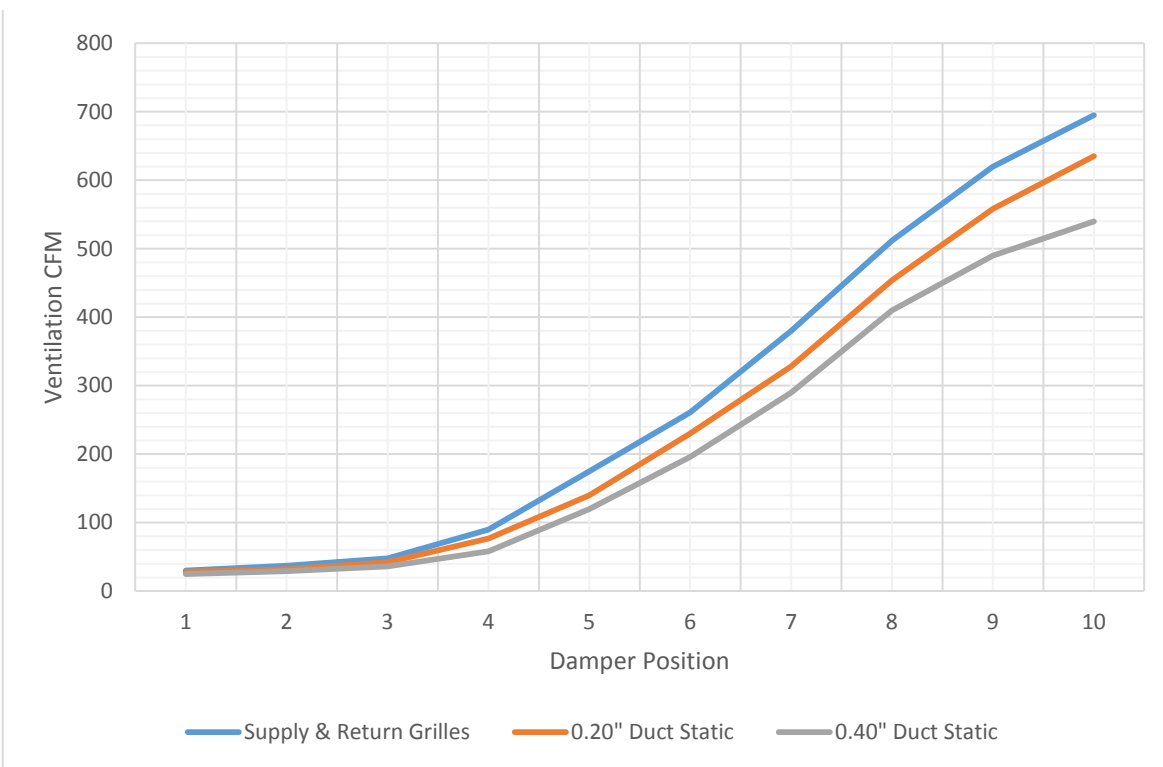

**GRAPH 2**  
**W30 and W36 Ventilation Delivery**

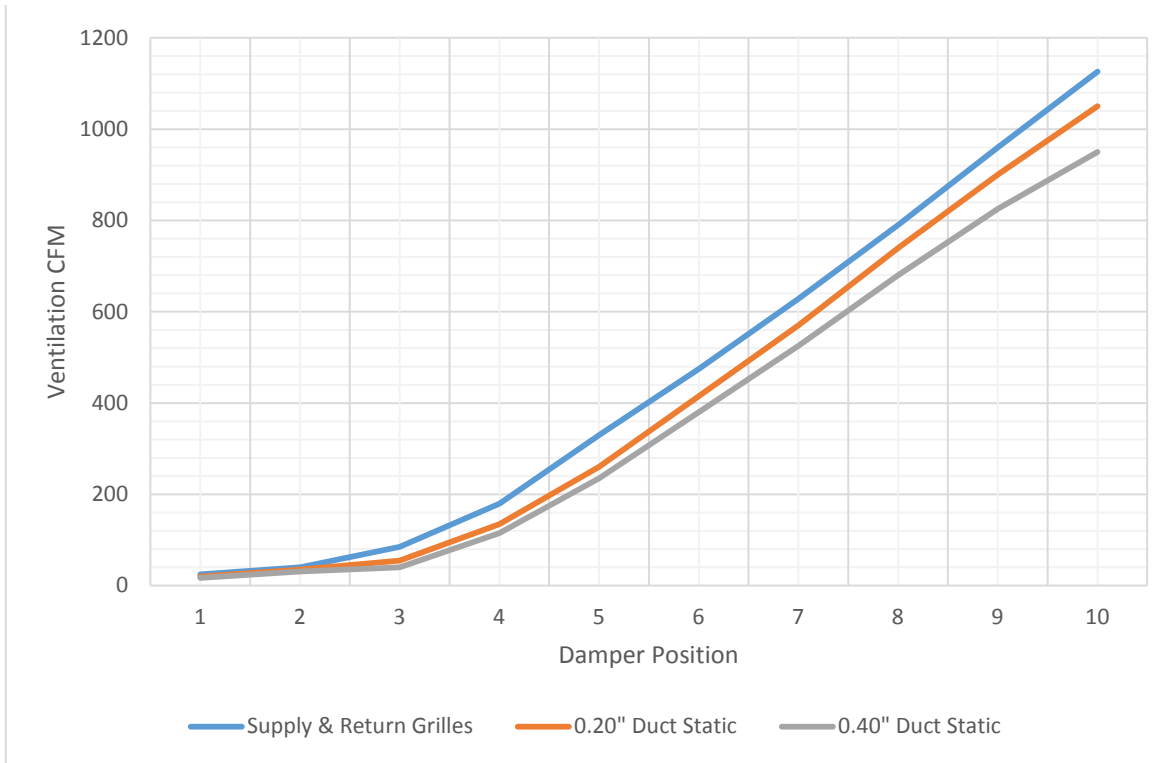

**GRAPH 3**  
**W42 and W48 Ventilation Delivery**

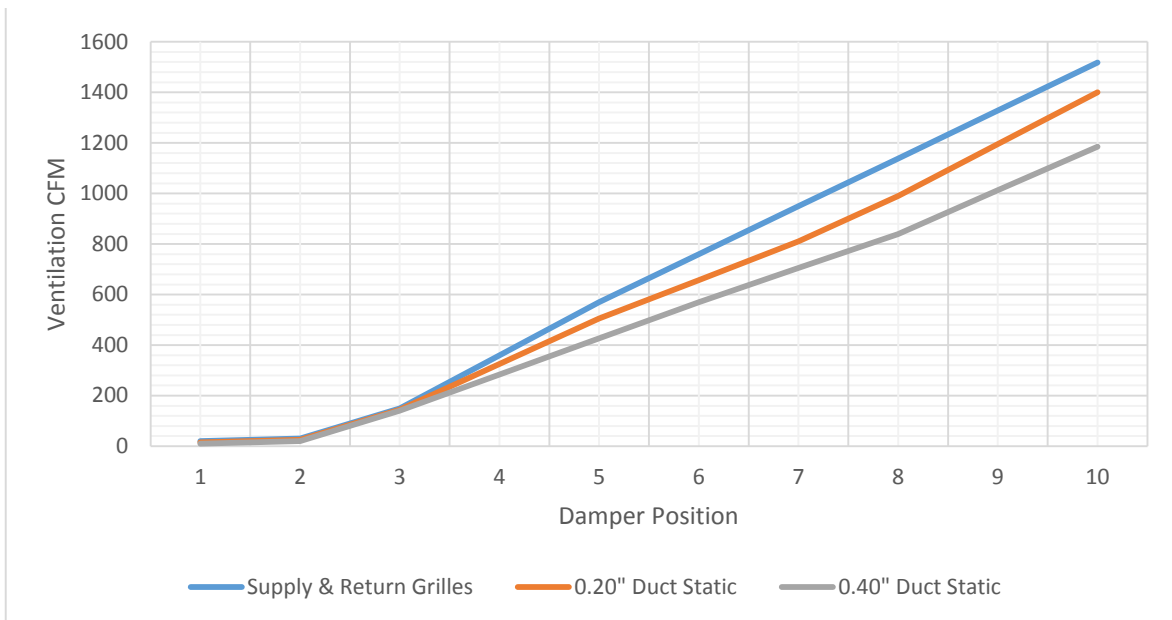

**GRAPH 4**  
**W60 Ventilation Delivery**

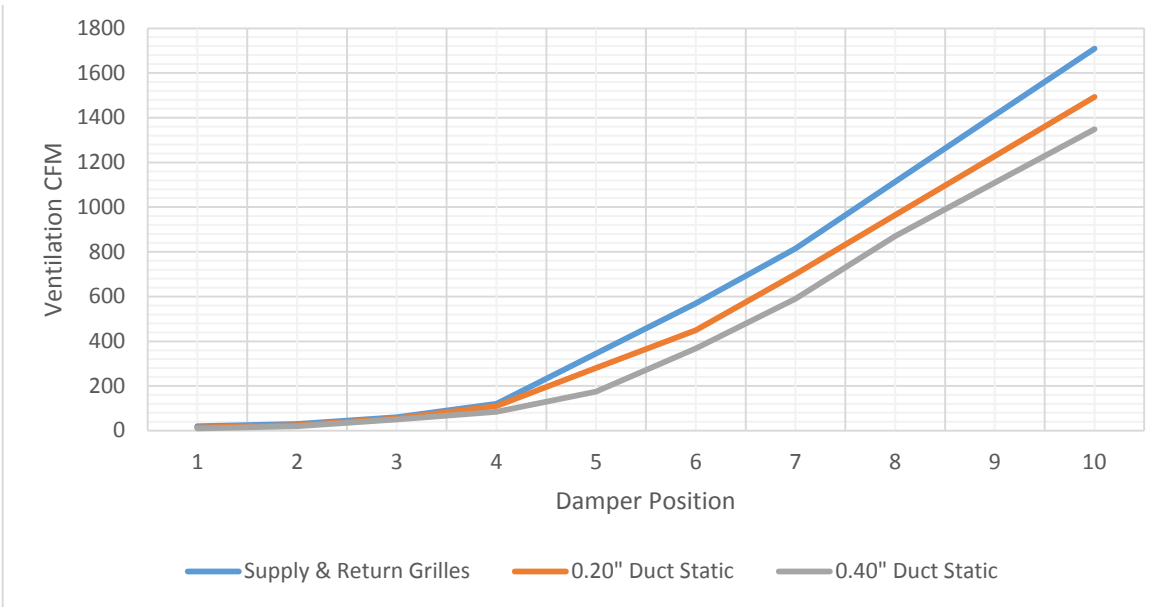

**GRAPH 5**  
**W72 Ventilation Delivery**

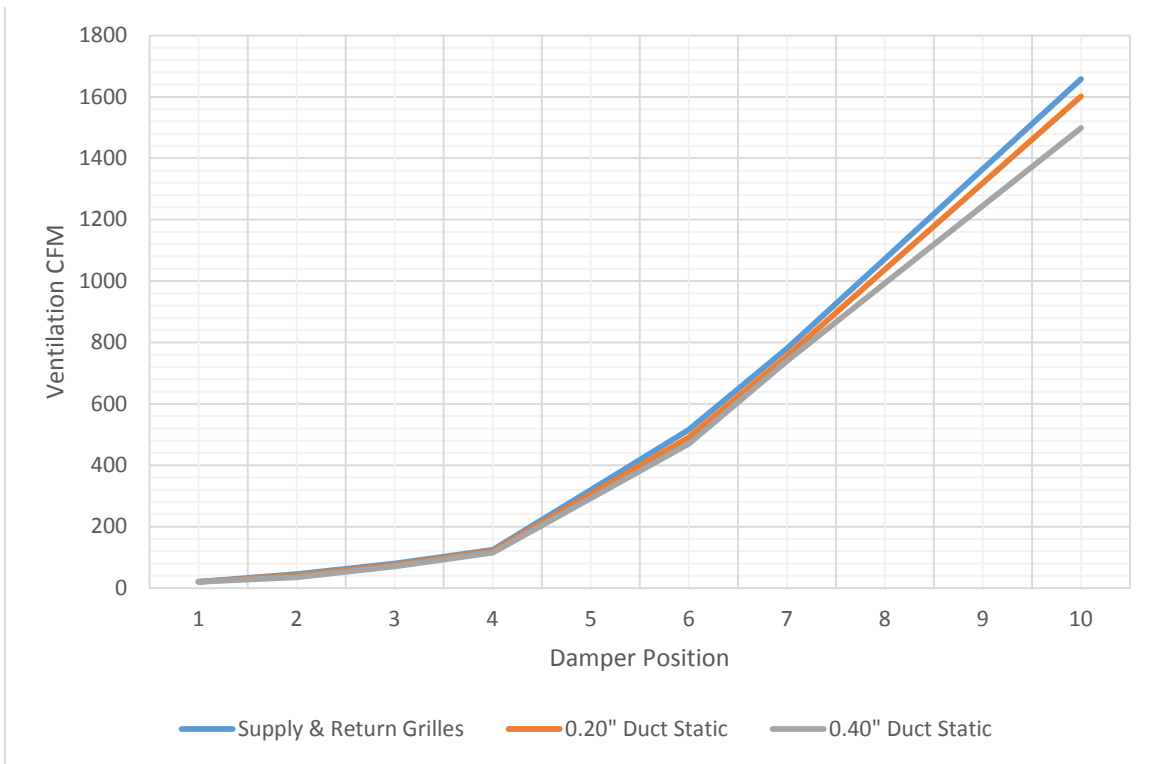

## COMMERCIAL ROOM VENTILATOR

### Features

- One piece construction – easy to install with no mechanical linkage adjustment required.
- Exhaust air damper – built in with positive closed position. Provides exhaust air capability to prevent pressurization of tight buildings.
- Actuator motor – 24 volt, power open, spring return with built in torque limiting switch.

### Commercial Room Ventilator Sequence of Operation

On a call for occupied conditions, CRV opens to a position as set by #1 Potentiometer (see Figure 11).

**NOTE:** These sequence descriptions do not apply if CO<sub>2</sub> controller is used. The CRV will control according to observed CO<sub>2</sub> levels in the conditioned space. Refer to information on page 13.

**FIGURE 11**  
Call for Ventilation With or Without Compressor Operation

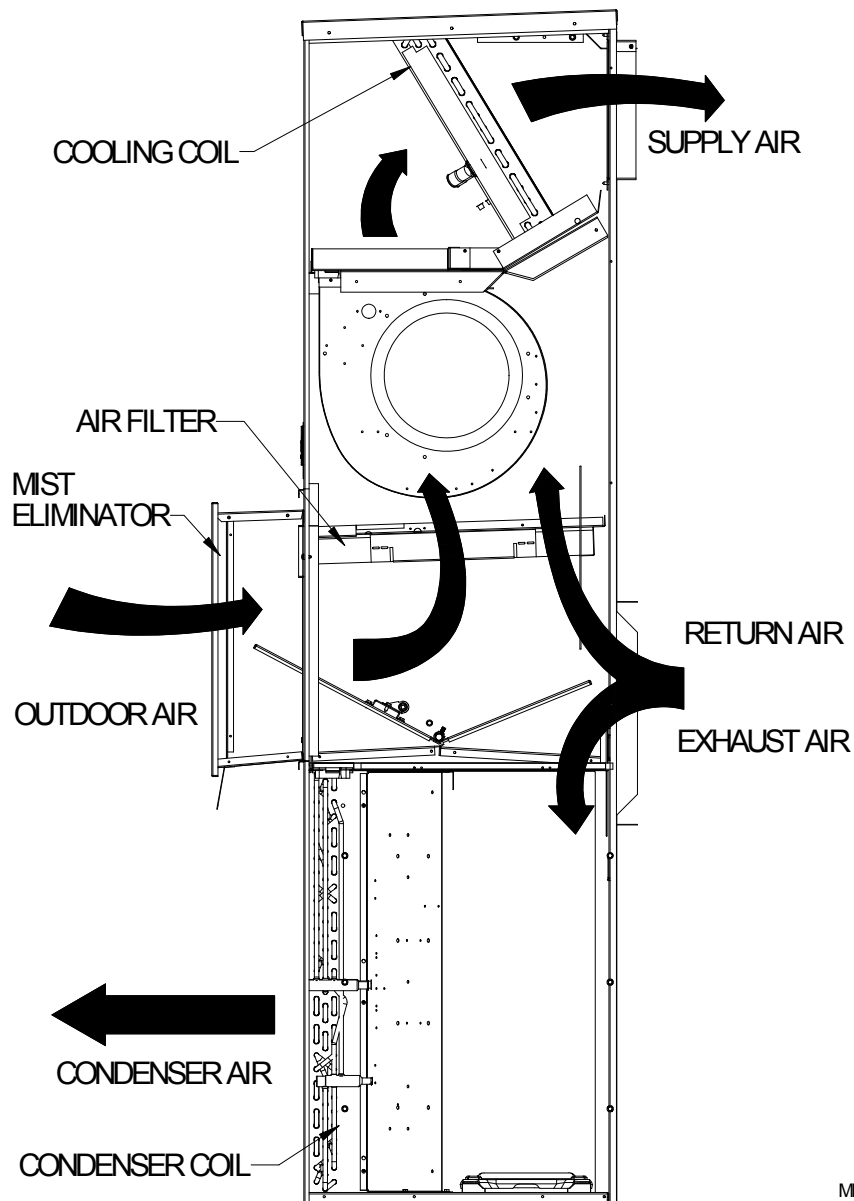

MS-3613

**FIGURE 12**  
**Call for Compressor or Fan Only with Ventilation Off**

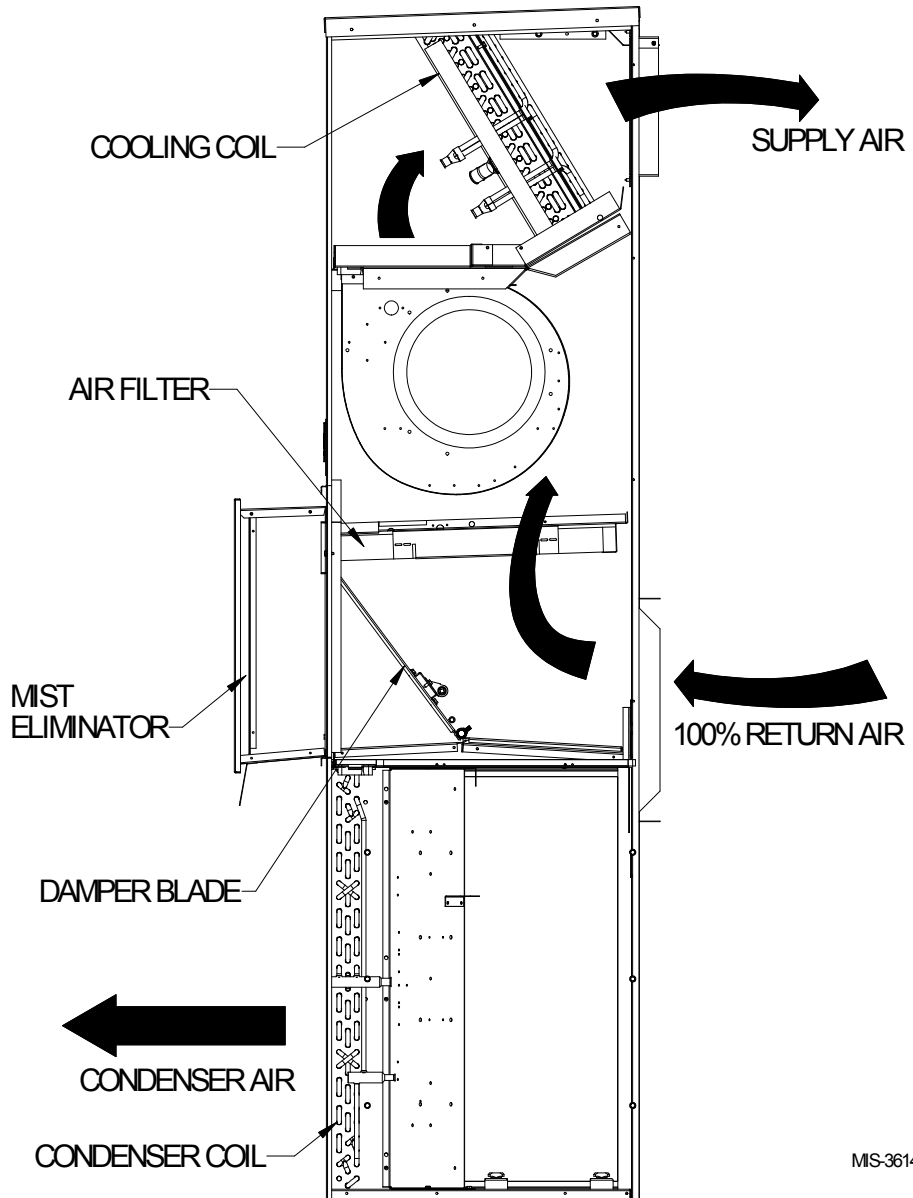

MIS-3614