

INSTALLATION INSTRUCTIONS

I-TEC Wall Sleeve for 4" and 6" Louvers

Model:
IWS-S02

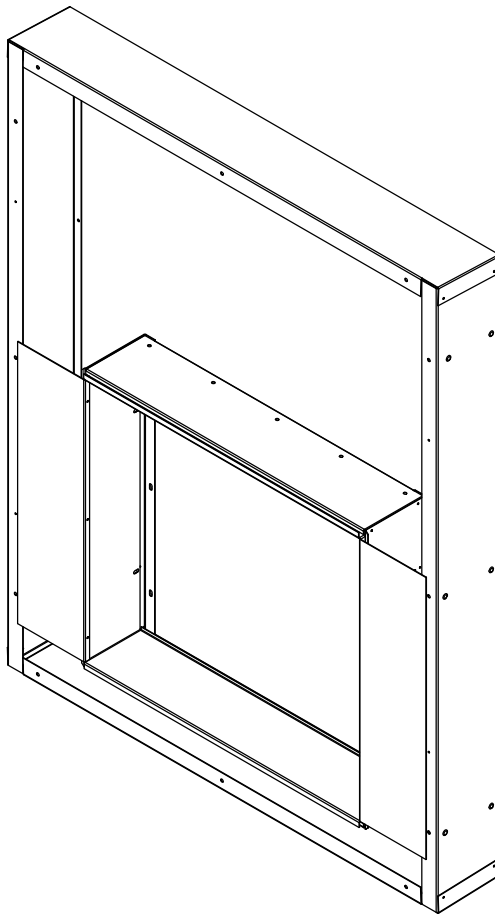

MIS-4538



Climate Control Solutions

Bard Manufacturing Company, Inc.
Bryan, Ohio 43506
www.bardhvac.com

Manual: 2100-668B
Supersedes: 2100-668A
Date: 8-29-24

CONTENTS

Installation

Shipping Damage	3
General	3
Installation – Masonry Construction Walls Only	3

Figures

Figure 1 Shipping Brackets	3
Figure 2 Wall Sleeve Dimensions	4
Figure 3 Masonry Construction Installation	5
Figure 4 Typical Installation	6
Figure 5 I-TEC and Wall Sleeve	7
Figure 6 Attachment of Wall Sleeve (Overview).....	8

Getting Other Information and Publications

These publications can help when installing the air conditioner or heat pump. They can usually be found at the local library or purchased directly from the publisher. Be sure to consult the current edition of each standard.

Standard for the Installation of Air Conditioning and Ventilating SystemsANSI/NFPA 90A

Standard for Warm Air Heating and Air Conditioning Systems.....ANSI/NFPA 90B

I-TEC Installation Instruction Manual (latest edition) Bard/2100-549

For more information, contact these publishers:

ACCA **Air Conditioning Contractors of America**
1712 New Hampshire Avenue, NW
Washington, DC 20009
Telephone: (202) 483-9370
Fax: (202) 234-4721

ANSI **American National Standards Institute**
11 West Street, 13th Floor
New York, NY 10036
Telephone: (212) 642-4900
Fax: (212) 302-1286

ASHRAE **American Society of Heating,
Refrigerating and Air Conditioning
Engineers, Inc.**
1791 Tullie Circle, N.E.
Atlanta, GA 30329-2305
Telephone: (404) 636-8400
Fax: (404) 321-5478

Bard **Bard Manufacturing Company, Inc.**
1914 Randolph Drive
Bryan, OH 43506
Telephone: (419) 636-1194
Fax: (419) 636-2640

Shipping Damage

Upon receipt of equipment, the carton should be checked for external signs of shipping damage. If damage is found, the receiving party must contact the last carrier immediately, preferably in writing, requesting inspection by the carrier's agent.

General

These instructions explain the recommended method to install the wall sleeve. The equipment covered in this manual is to be installed by trained service and installation technicians.

These instructions and any instructions packaged with any separate equipment required to make the entire air conditioning system should be carefully read before beginning the installation.

While intended as a general recommended guide, these instructions do not supersede any national and/or local codes in any way. Authorities having jurisdiction should be consulted before the installation is made.

Installation – Masonry Construction Walls Only

Remove shipping brackets prior to installation (see Figure 1).

This sleeve assembly is designed for special installation applications that require the louver and installation opening to be larger than 42-1/8" x 53". See Figure 2 (page 4) and Figure 3 (page 5). The field-supplied 4" to 6" deep louver design will meet up with the outer surface of the wall sleeve.

Begin the installation by attaching field-supplied louver to wall opening per local building codes and instructions provided by louver manufacturer (see Figure 4 on page 6). Measure distance from the louver to the inside wall surface. This distance plus 1/2" is needed to adjust sleeve assembly for installation (see Figure 3).

Remove inner and outer sleeve parts from packaging. Be sure to save parts bag and sleeve documentation.

FIGURE 1
Shipping Brackets

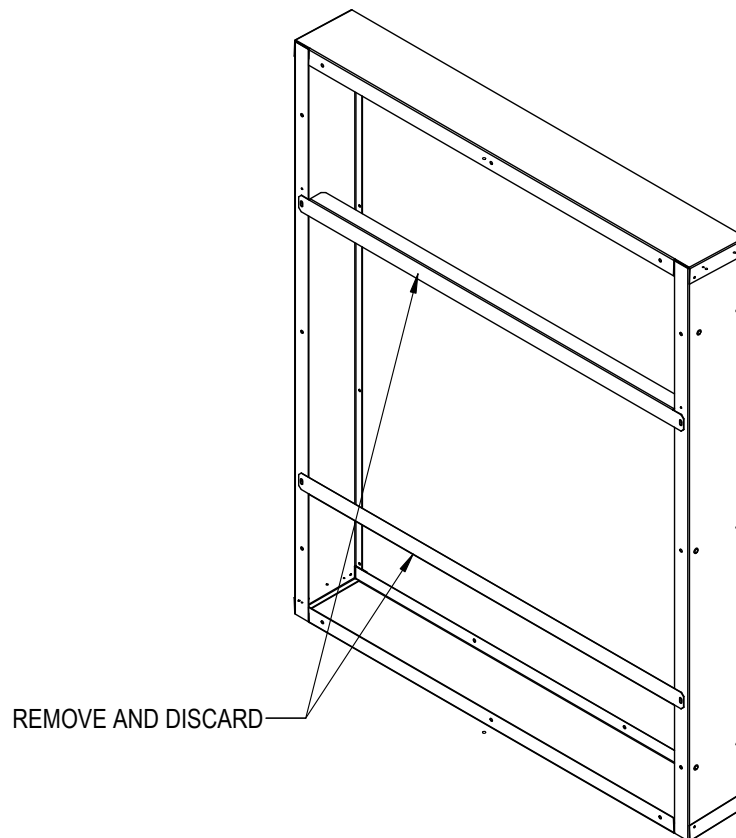

MIS-4537

FIGURE 2
Wall Sleeve Dimensions

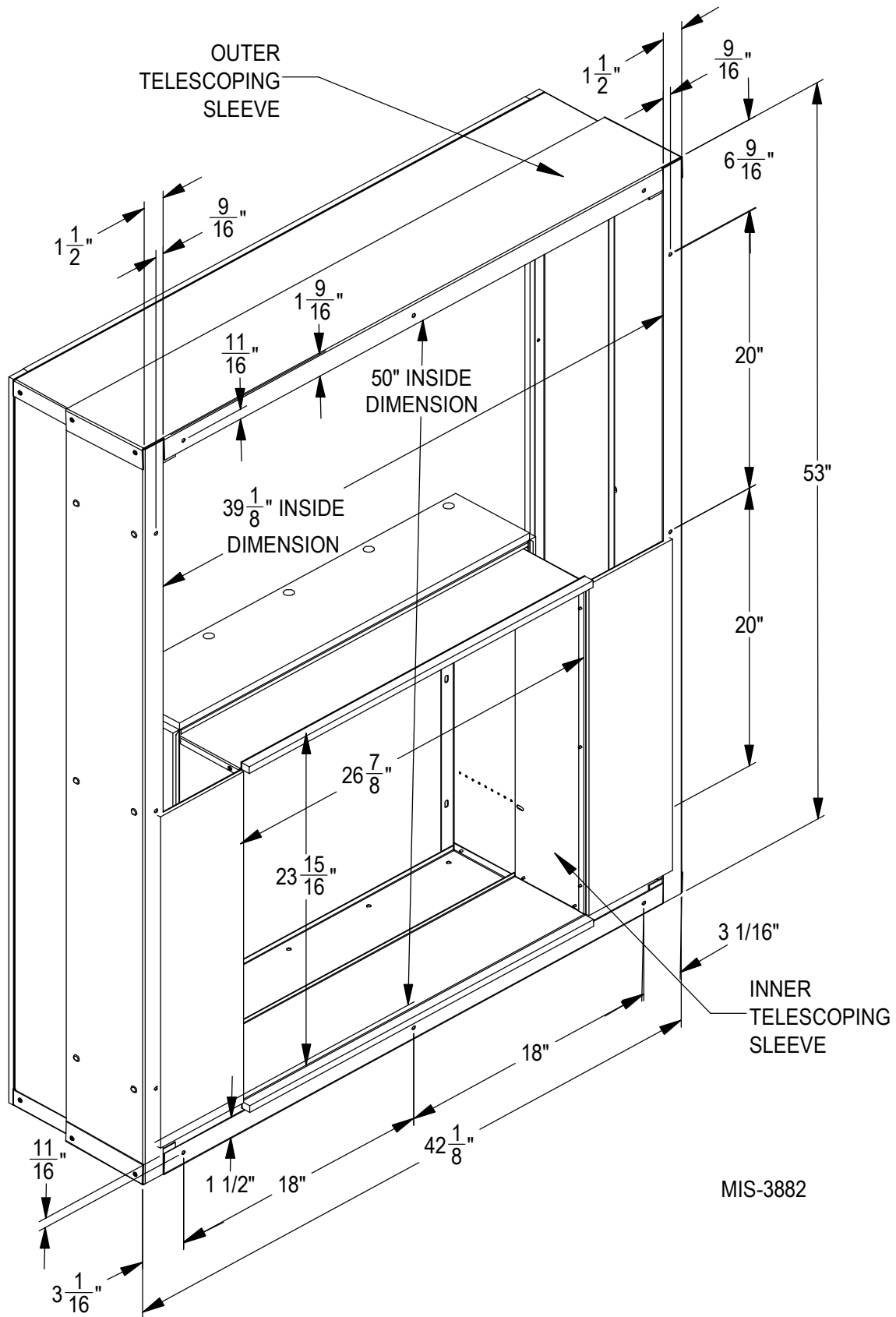
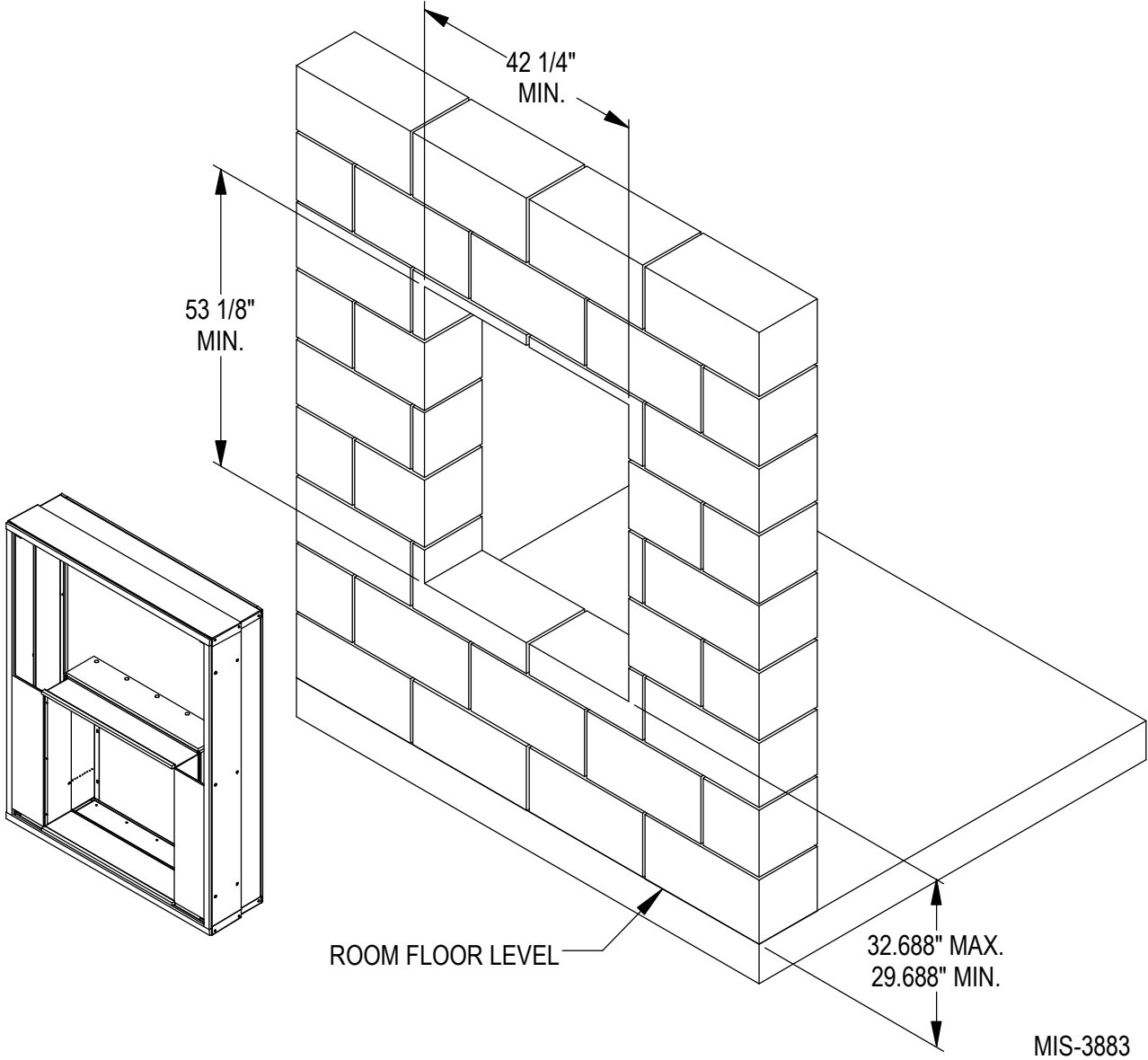
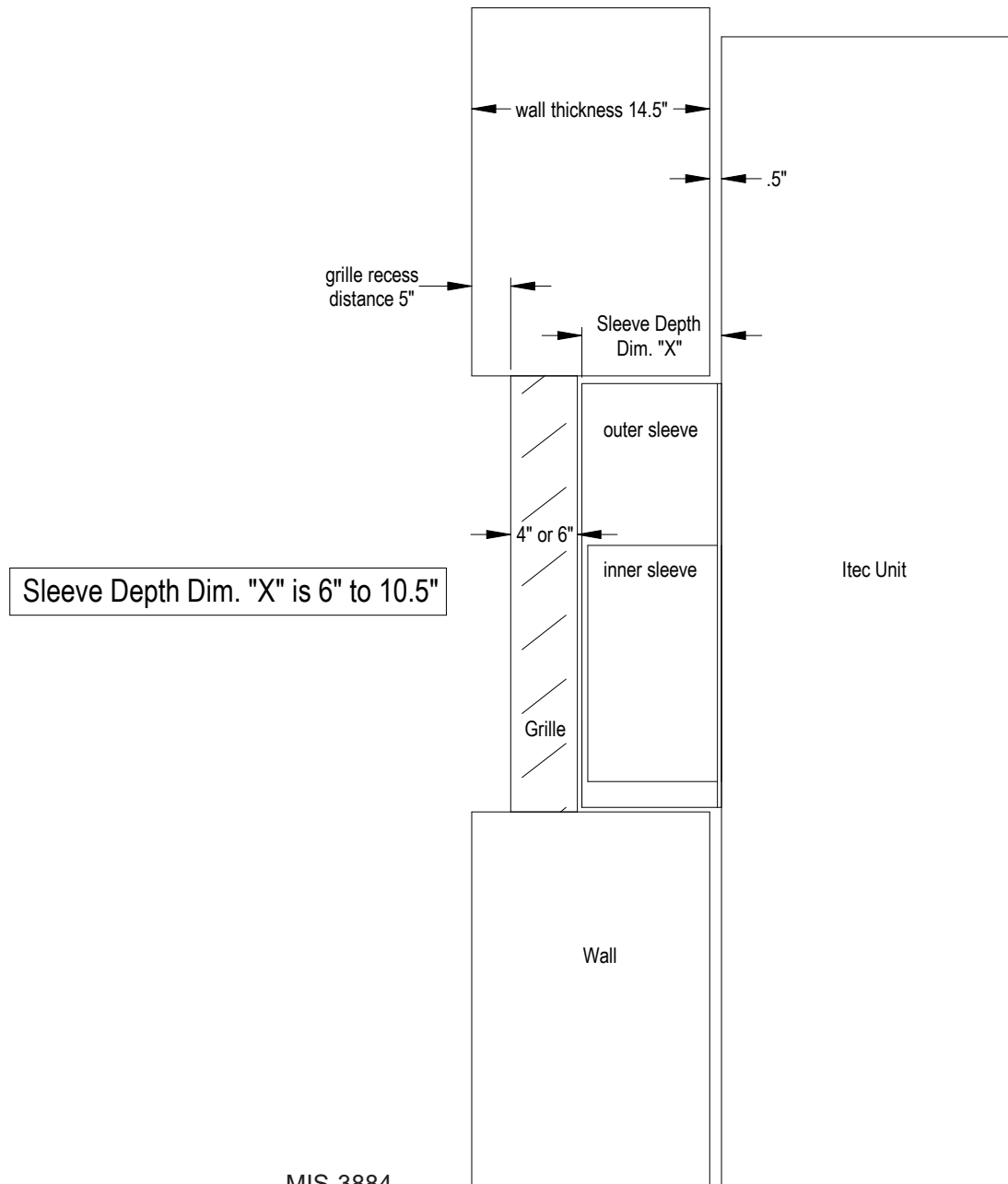

FIGURE 3
Masonry Construction Installation



MIS-3883

FIGURE 4
Typical Installation



Outer Telescoping Intake Sleeve Assembly and Installation

The outer telescoping intake sleeve is used to bring intake outdoor air into the unit (see Figure 5). Start assembly by setting sleeve parts on a flat surface. Extend assembly until outer finish size is the depth distance measured between the louver and the inner wall surface plus 1/2". Make sure assembly is square before attaching outer sleeve pieces using six (6) self-tapping 1/2" screws (supplied). Using the provided

caulk, seal all four (4) seams between the inner and outer parts of the assembly (see Figure 6 on page 8).

Next, measure distance from the bottom of the louver opening to the floor. This is the distance needed from the inner bottom surface of the outer sleeve to floor level (see Figure 5). The distance needed to ensure proper sleeve location on the unit is 31" to 34". Using this dimension and centering the sleeve side-to-side on the unit, attach the sleeve to the I-TEC unit using twelve (12) supplied self-tapping 3/4" long screws (see Figure 6).

FIGURE 5
I-TEC and Wall Sleeve

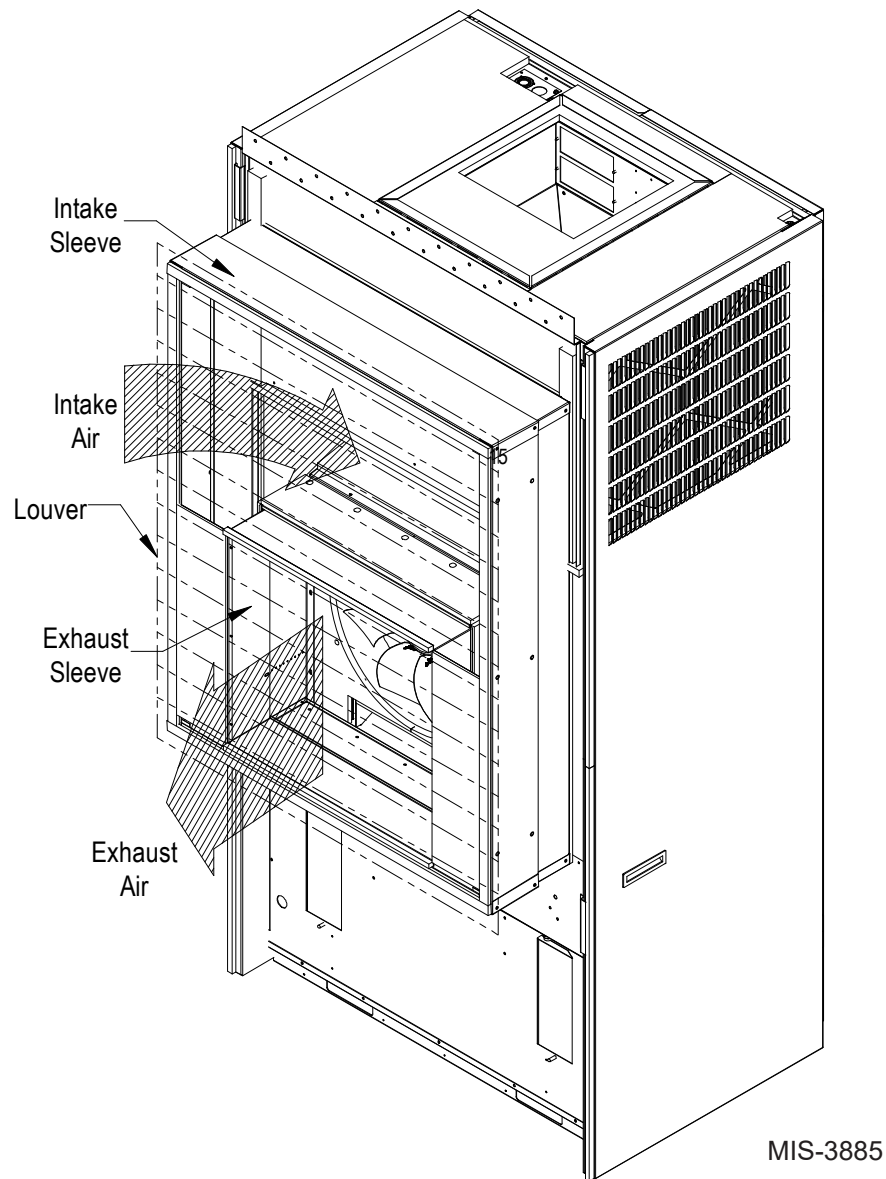

Inner Telescoping Exhaust Sleeve Assembly and Installation

The inner telescoping exhaust sleeve is used to direct condenser fan air out of the unit (see Figure 5). First, attach the inner exhaust sleeve to the I-TEC unit using six (6) 1/2" pointed sheet metal screws. Next, extend the inner frame of the exhaust sleeve until the outer surface is flush with the outer surface of the intake sleeve. Attach the inner frame of the exhaust sleeve to the outer portion using four (4) 1/2" pointed sheet metal screws (see Figure 6).

Sleeve and Louver Connection

Slide I-TEC unit and sleeve assembly into place until outer sleeve surface touches the louver (see Figures

4 and 6). This connection should compress the foam gasket attached to the outer sleeve surface. Using field-supplied fasteners, attach the louver to the sleeve assembly.

Final Inspection

After installation is complete, inspect all elements of the sleeve and louver assembly. Caulk may be needed to ensure air and water does not infiltrate room. Extra insulation may be required per installation variations to prevent sweating caused from surfaces being exposed to outdoor air. As a final step, verify that water entering the sleeve area can drain out of the sleeve and exit the louver. Weep holes may need to be provided in louver to ensure proper rain water drainage.

FIGURE 6
Attachment of Wall Sleeve (Overview)

