INSTALLATION INSTRUCTIONS

Multi-Position Commercial Room Ventilator with Exhaust and CO₂ Modulation (Optional)

Model:
WGSCRVMP-5A

For Use with Bard 3 Through 5 Ton
Step Capacity Wall Mount Air Conditioners
with Gas Heat



Climate Control Solutions

Bard Manufacturing Company, Inc.
Bryan, Ohio 43506
www.bardhvac.com

Manual : 2100-758B
Supersedes: 2100-758A
Date: 11-14-22

CONTENTS

General	3
General Information.....	3
Unpacking.....	3
Overview.....	3
Description.....	3
Models.....	3
Features.....	3
Installation	4
Basic Installation.....	4
“V” Option CRV Sequence of Operation.....	9
Blade Adjustment for Desired Ventilator Air.....	11
Adding Optional CO ₂ Control Sensor.....	14
Commercial Room Ventilator – WG*S Series.....	17

FIGURES

Figure 1	Removal of Exterior Panels.....	4
Figure 2	Install Ventilator	5
Figure 3	Install Loose Piece Wire Harness	6
Figure 4	Low Voltage Terminal Connections	7
Figure 5	WGSCRVMP-5A Lead Connections.....	8
Figure 6	CRV Control Board	9
Figure 7	8403-096 CO ₂ Sensor Set Up.....	15
Figure 8	Call for Blower Operation	16
Figure 9	Call for Cooling Operation	17
Figure 10	Low Voltage Wiring – Multi-Position Commercial Room Ventilator	18

TABLES

Table 1	For Use with Following Units.....	3
Table 2	Unit Operation with V (Variable CRV) Ventilation Option	10
Table 3	Factory Default Settings.....	11

GRAPHS

Graph 1	WG3S Ventilation Airflow	12
Graph 2	WG4S Ventilation Airflow	12
Graph 3	WG5S Ventilation Airflow	13

General Information

The ventilator should only be installed by a trained heating and air conditioning technician. These instructions serve as a guide to the technician installing the ventilator package. They are not intended as a step-by-step procedure with which the mechanically inclined owner can install the package.

The ventilator housing is shipped in one carton which contains the electrical harness, step control assembly, miscellaneous hardware and installation instructions.

Unpacking

Upon receipt of the equipment be sure to compare the model number found on the shipping label with the accessory identification information on the ordering and shipping document to verify that the correct accessory has been shipped.

Inspect the carton housing of each ventilator as it is received, and before signing the freight bill, verify that all items have been received and that there is no visible damage. Note any shortages or damage on all copies of the freight bill. The receiving party must contact the last carrier immediately, preferably in writing, requesting inspection by the carrier's agent. Concealed damage not discovered until after loading must be reported to the carrier within 15 days of its receipt.

Overview

The multi-position commercial room ventilator (CRV) allows outdoor air to be brought into a room or structure and simultaneously provides additional exhaust air to the condenser section. The CRV can be operated using either a 24VAC input or a 0-10V input from a controller or thermostat. The damper may also be wired to open during blower operation. A modulating damper motor with spring return is operated by a solid state board located on the ventilator.

Description

The WGSCRVMP-5A ventilator is designed to be used with Bard 3 through 5 ton WGS wall mount series step capacity air conditioners. It is an electromechanical vent system designed to provide fresh air to meet indoor air quality standards. It automatically adjusts to the mode of operation to maintain consistent fresh air intake levels. Examples are blower only, stage 1 cooling and stage 2 cooling, which are all set for different total airflows. This is achieved via a ventilation control board located on the vent itself. Potentiometers on the CRV control board are provided to adjust damper blade positions during all modes of operation. Pre-purge, occupied and unoccupied airflow amounts are possible with capable thermostats and controllers.

The WGSCRVMP-5A also allows for 0-10V input for modulating ventilation control based on CO₂ levels.

Models

When installed in the models listed in Table 1, the WGSCRVMP-5A provides built-in exhaust provisions. When the damper blade opens to bring fresh air in, the damper also opens an exhaust relief. The exhaust air will flow into the condenser section of the unit. The condenser fan will help draw exhaust air out.

TABLE 1

Models	For Use with the Following Units
WGSCRVMP-5A	WG3S WG4S WG5S

Features

- One piece construction: Easy to install with no mechanical linkage adjustment required.
- Exhaust air damper: Built in with positive closed position. Provides exhaust air capability to prevent pressurization of tight buildings.
- Actuator motor – 24 volt, power open, spring return with built-in torque limiting switch.
- Solid state control board – can be used for ON/OFF or 2-10VDC operation. Timed pre-purge feature to provide increased ventilation before occupancy. Potentiometers used to set blade position for ON/OFF ventilation amount.
- Provides up to 75% of outside air.

INSTALLATION

WARNING

Open and lock unit disconnect switch before installing this accessory to prevent injury or death due to electrical shock or contact with moving parts. Turn the thermostat to off.

Basic Installation

1. Unpack the ventilator assembly which includes the integral ventilator with attached electrical harness, step control assembly and miscellaneous hardware.
2. Remove and save the existing exterior blower access and service access panels (see Figure 1).
3. Remove and discard exhaust cover plate (see Figure 1).
4. In rear of opening towards duct connection, install exhaust opening adaptor plate (included).
5. Install ventilator sheet metal assembly by inserting the ventilator into the unit, centering between the tubing on the left and the control panel on the

FIGURE 1
Removal of Exterior Panels

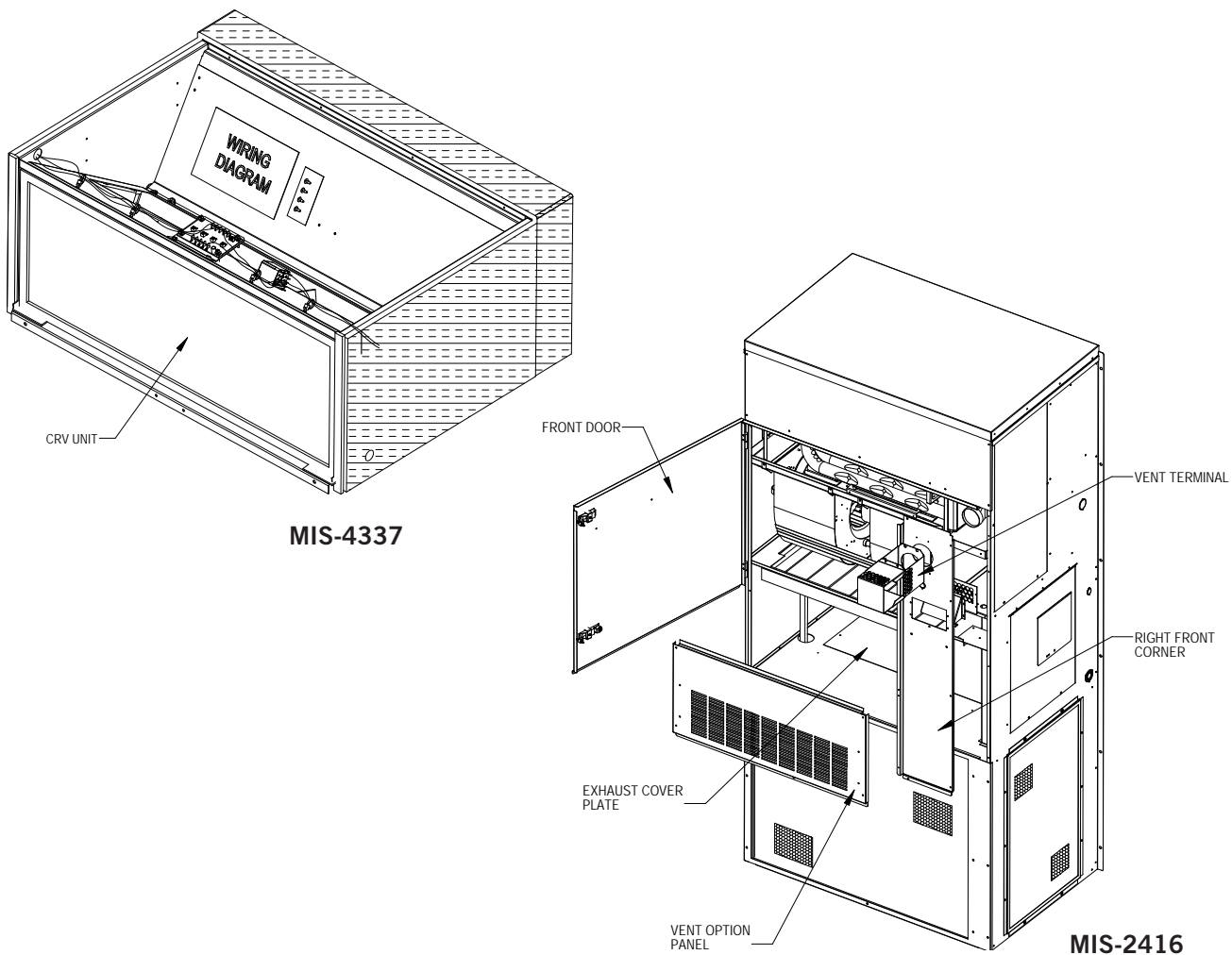

right. Once the ventilator is fully inserted, slide the ventilator to align screw hole through the front of the condenser grille (see Figure 2).

IMPORTANT: Position front lip of ventilator on top of front grille and condenser partition (see Figure 2 inset). This is important to ensure proper drainage of any water entering damper assembly.

6. Open control panel to gain access to unit low voltage terminal block.
7. Install loose piece wire harness plug into filter tray and route wires into low voltage box (see Figure 3 on page 6).
8. Plug wire plug from vent package installed in Steps #1 through #6 into plug installed in Step #7.

FIGURE 2
Install Ventilator

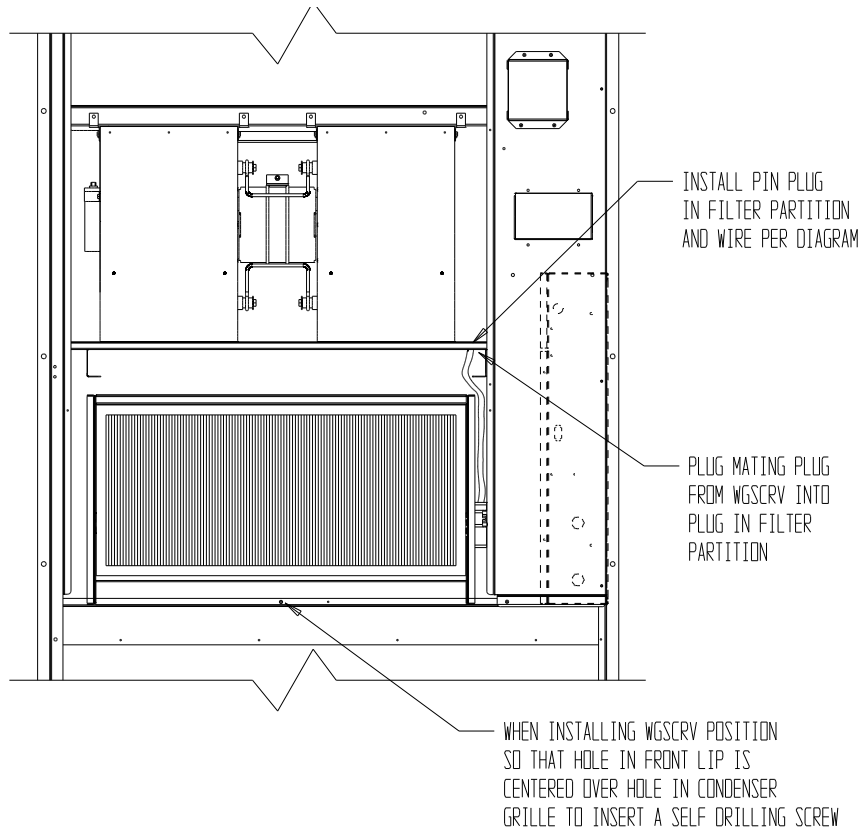
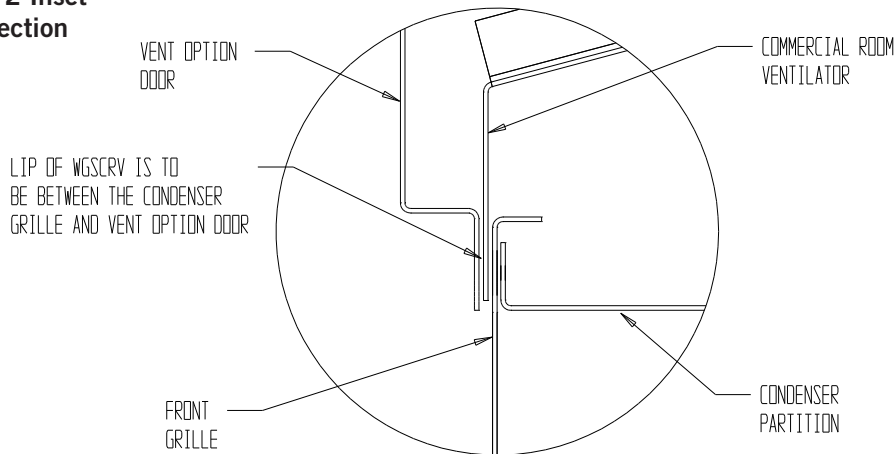
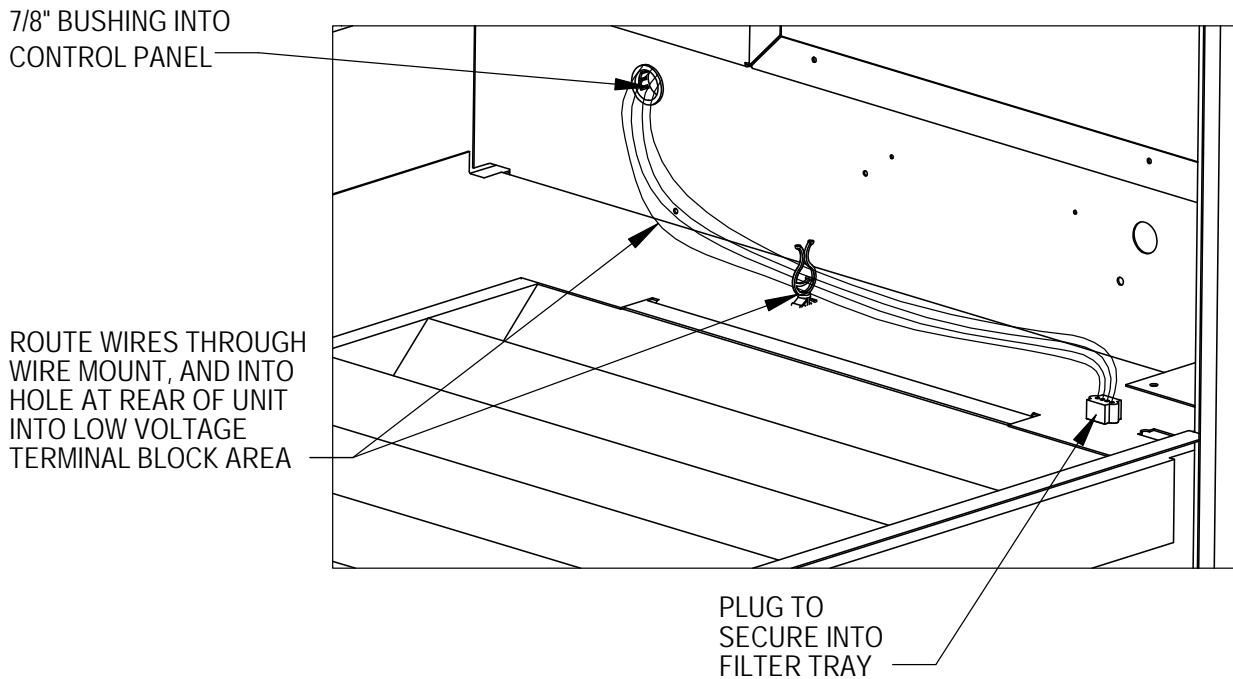

FIGURE 2 Inset
Side Section



MIS-2455 A

FIGURE 3
Install Loose Piece Wire Harness Plug



MIS-2415 A

9. The wires in the low voltage box from Step #8 connect to the 24 volt thermostat connection strip as follows per Figure 4 and Figure 5 (page 8):
 - Black/White to terminal "C"
 - Red/White to terminal "R"
 - Yellow/White to terminal "Y1"
 - Purple to terminal "Y2"
 - Blue to terminal "W1"
 - Brown to terminal "W2"
 - Brown/White to terminal "A". If connected to "A" and it is a thermostat or control system with an occupied output, ventilation can be regulated during occupied conditions. Wire "A" to "G" to operate the ventilator during blower operation if the controls do not have an occupied output.
 - Gray wire with tab connector will be unlanded in control panel unless a 0-10V control is used (tape off if 0-10V control is not used).
10. Replace right front unit corner and vent terminal.
11. Close upper unit door to seal blower discharge air.
12. Ventilator checkout

NOTE: *It may be more efficient to disconnect the thermostat from the low voltage terminal strip and use a set of jumper wires to perform these steps.*

- A. Resupply power to the unit.
- B. Move the pre-purge jumper to the 30-minute position on the step control board located behind the front fill partition, accessible from the top of the vent through the filter tray.
- C. Energize the evaporator blower by switching thermostat to the manual fan position with heat/cool in OFF position. (**Jumper "R" to "G" to "A"**)
- D. Ventilator should open to the position set by the PP potentiometer on step control board (see Figure 6 on page 9).
- E. Move the pre-purge jumper back to the "O" position on the step control board.
- F. Ventilator should open to the position set by OCC potentiometer on step control board (see Figure 6).
- G. Now energize Stage #1 cooling/heating by switching the thermostat to the corresponding mode and setting the temperature offset slightly beyond the actual room temperature. (**Jumper "R" to "G" to "A" and "Y1"**)
- H. Ventilator should now open to the position set by Y1 potentiometer on step control board (see Figure 6).
- I. Now energize the Stage #2 cooling/heating by increasing the thermostat setting to a greater

FIGURE 4
Low Voltage Terminal Connections

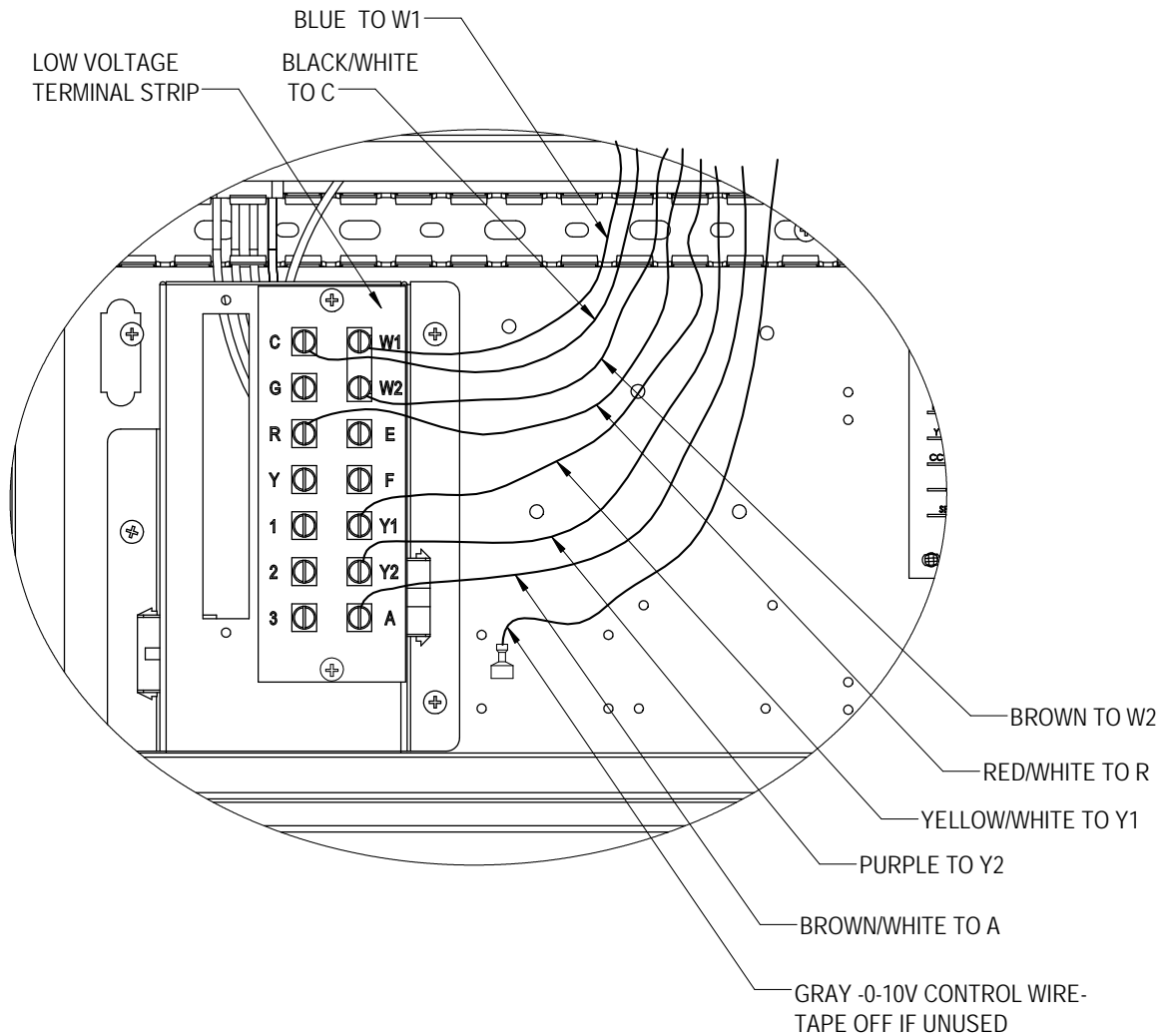

- offset than the actual room temperature.
(Jumper "R" to "G" to "A", "Y1" and "Y2")
- J. Ventilator should now open to the position set by Y2 potentiometer on step control board (see Figure 6).
 - K. Now turn the heat/cool selector to OFF and set the fan switch back to AUTO; the damper blade should close. **(Remove all jumper connections)**
 - L. This completes the ventilator checkout.
13. Adjust damper blade for required ventilation. (See **Blade Adjustment for Desired Ventilator Air** on page 10.)
 14. Replace mist eliminator filter. Be sure that it is installed with the drain holes to the bottom.
 15. Remove blank off plate installed on lower service access door. Plug four (4) mounting holes with the plastic plugs provided with the ventilator.
 16. Replace service access panel.
 17. Close control panel cover.
 18. Ventilator is now ready for operation.

FIGURE 5
WGSCRVP-5A Lead Connections

*A - ON/OFF CO2 CONTROL	KEY
*B - ADD FOR CO2 CONTROL	
 ALTERNATE CONNECTION FOR CONSTANT VENTILATION ON A BLOWER SIGNAL	
----- REQUIRED FIELD WIRING FOR OPTIONAL CO2 CONTROL	

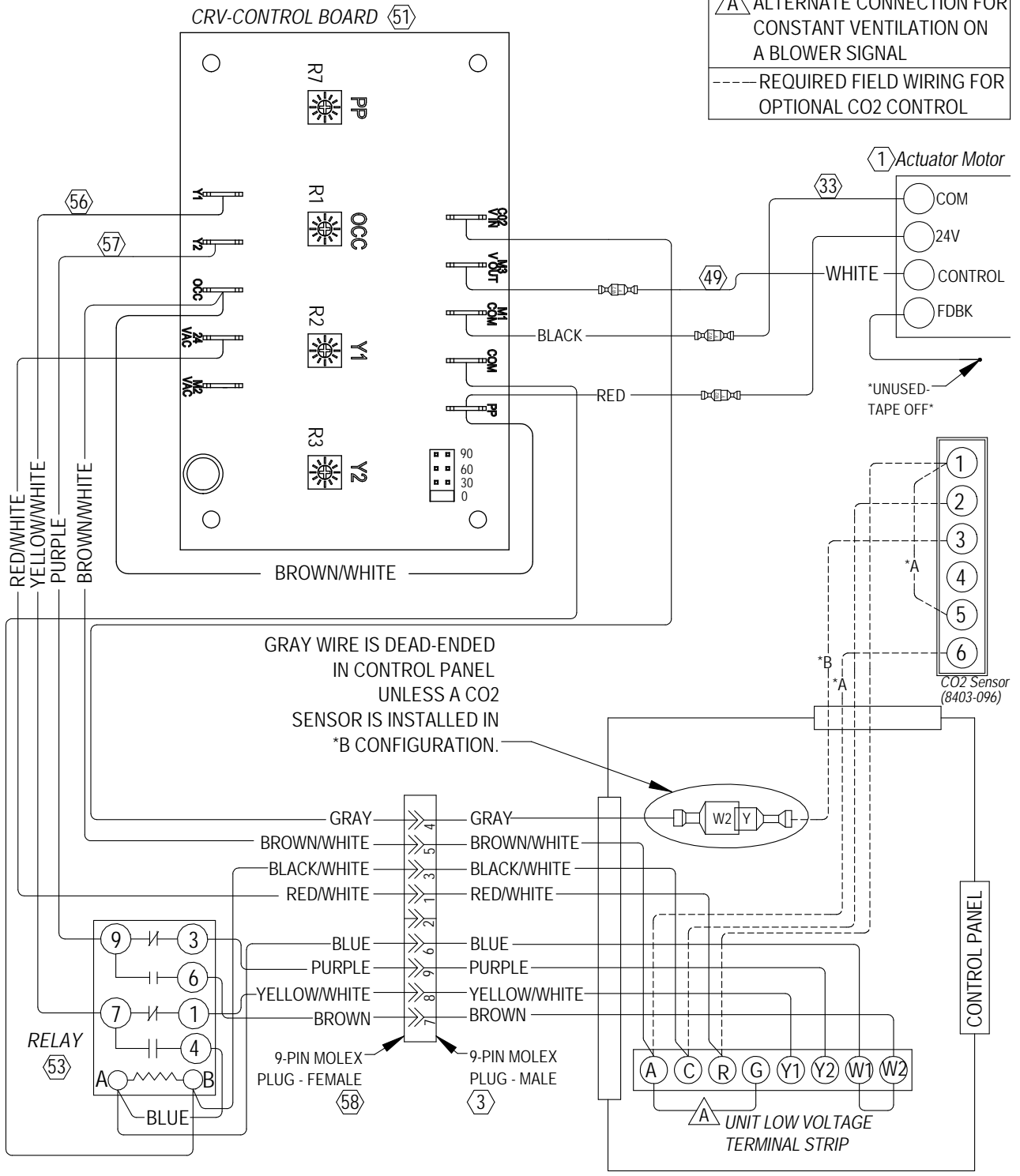

4056-264 D

"V" Option CRV Sequence of Operation

The "V" Ventilation option includes a control board with blade positioning potentiometers along with an input for a 2-10V input signal (see Figure 6).

Adjustable potentiometers:

"PP" Potentiometer setting: This potentiometer can be used to adjust the blade setting for outdoor air intake during a pre-purge cycle. The pre-purge cycle time is based on the setting of the pre-purge timer.

"OCC" Potentiometer setting: This potentiometer can be used to adjust the blade setting for outdoor air intake when the "A" terminal is energized on the low voltage terminal strip indicating occupancy.

"Y1" Potentiometer setting: This potentiometer can be used to adjust the blade setting for outdoor air intake when the "Y1" terminal is energized on the low voltage terminal strip indicating 1st stage cooling or Balanced Climate operation. When energized, it overrides the "OCC" potentiometer setting.

"Y2" Potentiometer setting: This potentiometer can be used to adjust the blade setting for outdoor air intake when the "Y2" terminal is energized on the low voltage terminal strip indicating 2nd stage cooling operation. When energized, it overrides the "OCC" and "Y1" potentiometer settings.

Pre-Purge Feature

Pre-purge is used to ventilate a specified CFM amount before occupants enter the room or structure. The control board has a built-in pre-purge timer that can be set to 30, 60 and 90 minute intervals by moving the jumper noted in Figure 6. This timer will start when the jumper is installed and the A terminal is energized on the low voltage terminal strip. Blade adjustment can be made on the PP potentiometer. Once the timer has timed out, the board will default to the occupied setting and this blade position can be adjusted on the OCC potentiometer. If the timer is set to 0 (off—shipped position), the occupied setting is instantaneous and the pre-purge setting (PP) is no longer in the sequence.

FIGURE 6
CRV Control Board

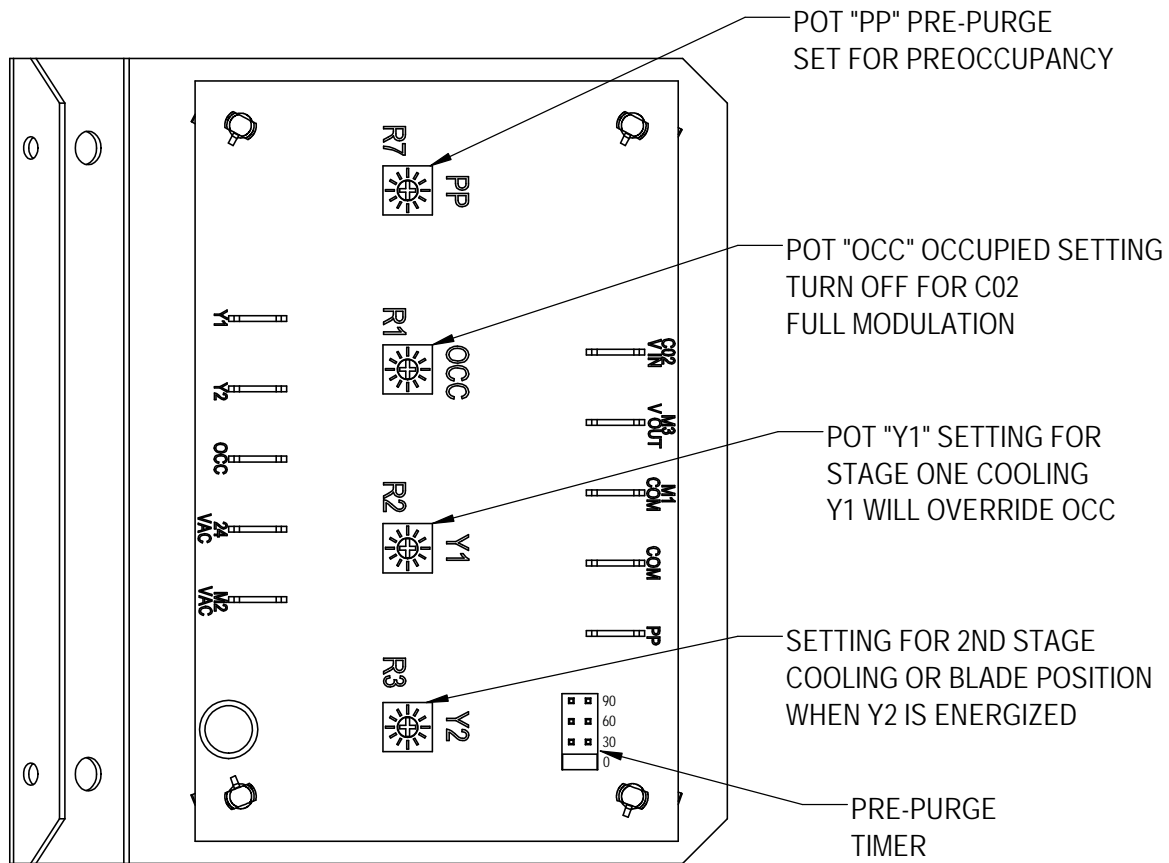

MIS-4362 B

Occupied Setting

Occupied is used to ventilate a specified CFM amount when occupants enter the room or structure. The control board will energize the occupied setting after the pre-purge cycle, or if pre-purge is disabled immediately when the A terminal is energized on the low voltage strip. Blade adjustment can be made on the OCC potentiometer.

Y1 Setting

Y1 is used to ventilate a specified CFM amount when Y1 cooling is energized. If Balanced Climate operation is used, the Y1 setting should be set to a blade setting that will allow additional outdoor intake air. The control board will energize the Y1 setting when Y1 is energized on the low voltage strip. Blade adjustment can be made on the Y1 potentiometer. This potentiometer setting overrides the OCC occupied setting.

Y2 Setting

Y2 is used to ventilate a specified CFM amount when Y2 cooling is energized. The blade setting for the Y2 potentiometer must be set to match the occupied setting (OCC potentiometer) in order to bring in the same amount of outdoor air when non-Balanced Climate cooling occurs. The control board will energize the Y2 setting when Y2 is energized on the low voltage strip. Blade adjustment can be made on the Y2 potentiometer. This potentiometer setting overrides the OCC occupied and the Y1 setting.

2-10V Operation

A CO₂ sensor or other device sending a 2-10V signal can be used to control the damper motor. Two control methods are available to control the damper motor:

- Method 1: The control board will accept a 2-10VDC signal with a resistive load greater than 5000 ohms. Bard CO₂ sensor part #8403-096 can be used when the 2-10V output is connected to the unlanded gray wired on the vent control harness using a 1/4" quick-connect. The occupied OCC potentiometer setting must be set to the off position for total modulation. The OCC potentiometer can be used to maintain a minimum blade position when A is energized.
- Method 2: The damper motor will accept a 2-10VDC signal with a resistive load less than 5000 ohms. This method involves bypassing the control board and powering the motor directly from the device providing the 2-10VDC modulating signal. The unlanded gray wired on the vent control harness (2-10V IN on control board) must be spliced with the white wire ran to the damper motor (2-10V OUT on control board). The 2-10VDC signal can be connected to the quick-connect fitting on the unlanded gray wire in the unit control panel.

During 2-10VDC operation with A energized and pre-purge timed operation active, DC voltage signaling occupancy from a source such as a CO₂ sensor will increase ventilation amounts as needed.

TABLE 2
Unit Operation with V (Variable CRV) Ventilation Option

Unit Operation	Occ. Signal	Low Voltage 24VAC							Fan Speed	Comp. Oper.	Damper Pot.	
		G	Y1	Y2	W1	W2	A	D				
Fan Only	Yes	X						X		Vent	Off	PP/OCC
Fan Only	No	X								Vent	Off	Closed
BC Cooling*	Yes		X					X		B Climate	On	Y1
BC Cooling*	No		X							B Climate	On	Closed
Full Load Cool	Yes		X	X				X		Full Load	On	Y2
Full Load Cool	No		X	X						Full Load	On	Closed
1st Stage Heat	Yes				X			X		Full Load	Off	Y2
1st Stage Heat	No				X					Full Load	Off	Closed
2nd Stage Heat	Yes				X	X		X		Full Load	Off	Y2
2nd Stage Heat	No				X	X				Full Load	Off	Closed

BC and B Climate – Balanced Climate

* Y1 and Y2 jumper must be removed on low voltage terminal block connections and 2 stage thermostat must be utilized.

Blade Adjustment for Desired Ventilation Air

The amount of ventilation air supplied by the commercial room ventilator is dependent on five factors.

1. Return air duct static pressure drop.
2. Supply air duct static pressure drop.
3. Indoor blower motor speed.
4. Damper blade open position setting for each mode of operation.
5. Tightness or looseness of building envelope.

Set the damper position for each mode of operation using the set-point potentiometers on the step control board (see Figure 6 on page 9). See Table 3 for factory default settings.

Refer to the graphs on the following pages to determine the necessary blade setting to achieve the ventilation air required based upon blower only Stage #1 and Stage #2 modes of operation. Match the chart to the specific model being worked on as the charts are model specific.

TABLE 3
Factory Default Settings

Mode of Operation	Potentiometer	WG3		WG4		WG5	
		Blade Setting	Approx. CFM	Blade Setting	Approx. CFM	Blade Setting	Approx. CFM
Vent	R1	4	125	4	125	4	125
Part Load (Stage 1)	R2	3.5	100	3.5	150	3.5	200
Full Load (Stage 2)	R3	2.5	125	2.5	150	2.5	175

NOTE: Heating operation will always be equivalent to Full Load Cooling (Stage 2).

GRAPH 1
WG3S Ventilation Airflow

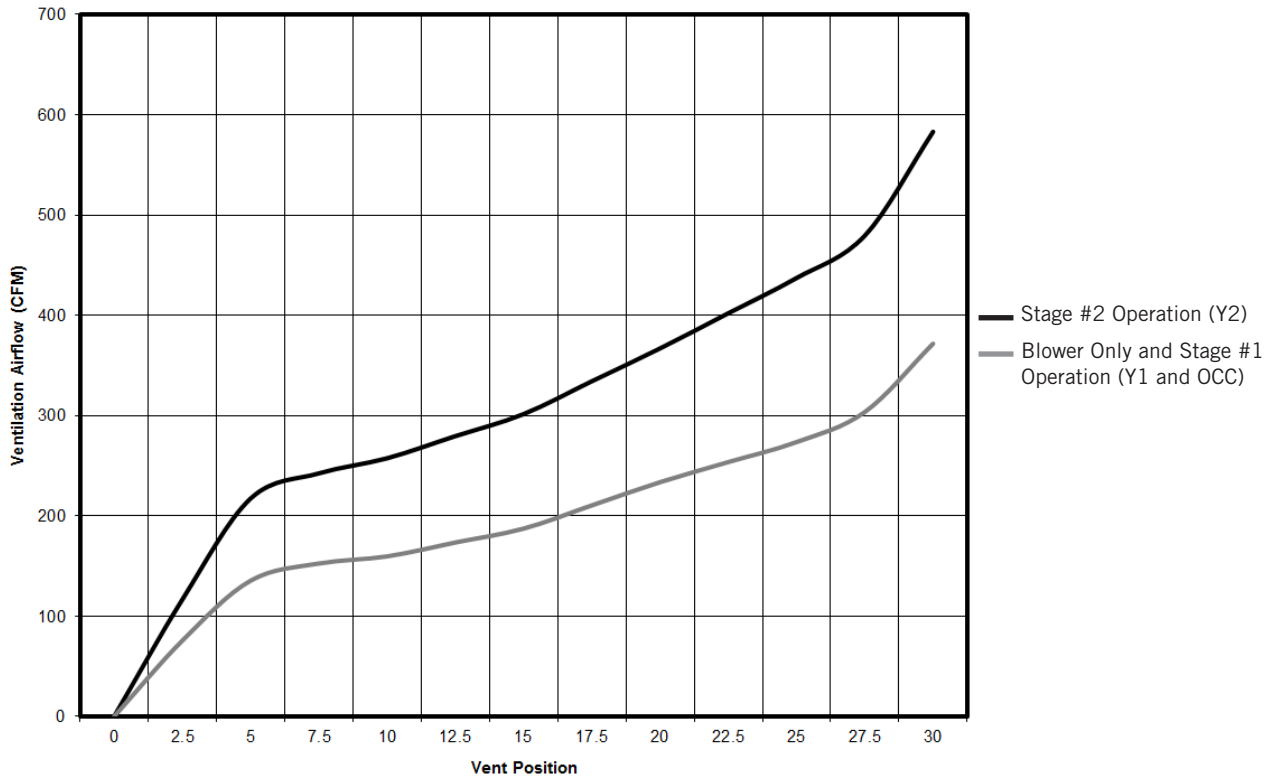

GRAPH 2
WG4S Ventilation Airflow

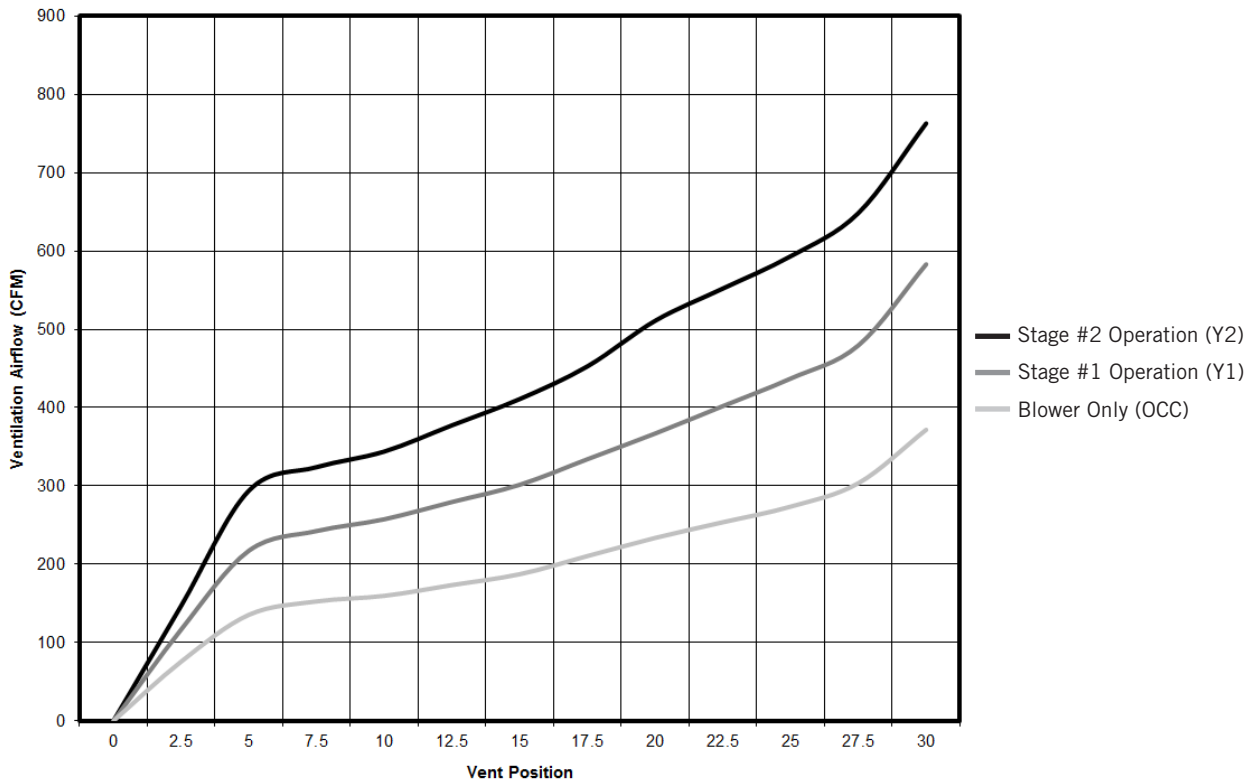

GRAPH 3
WG5S Ventilation Airflow

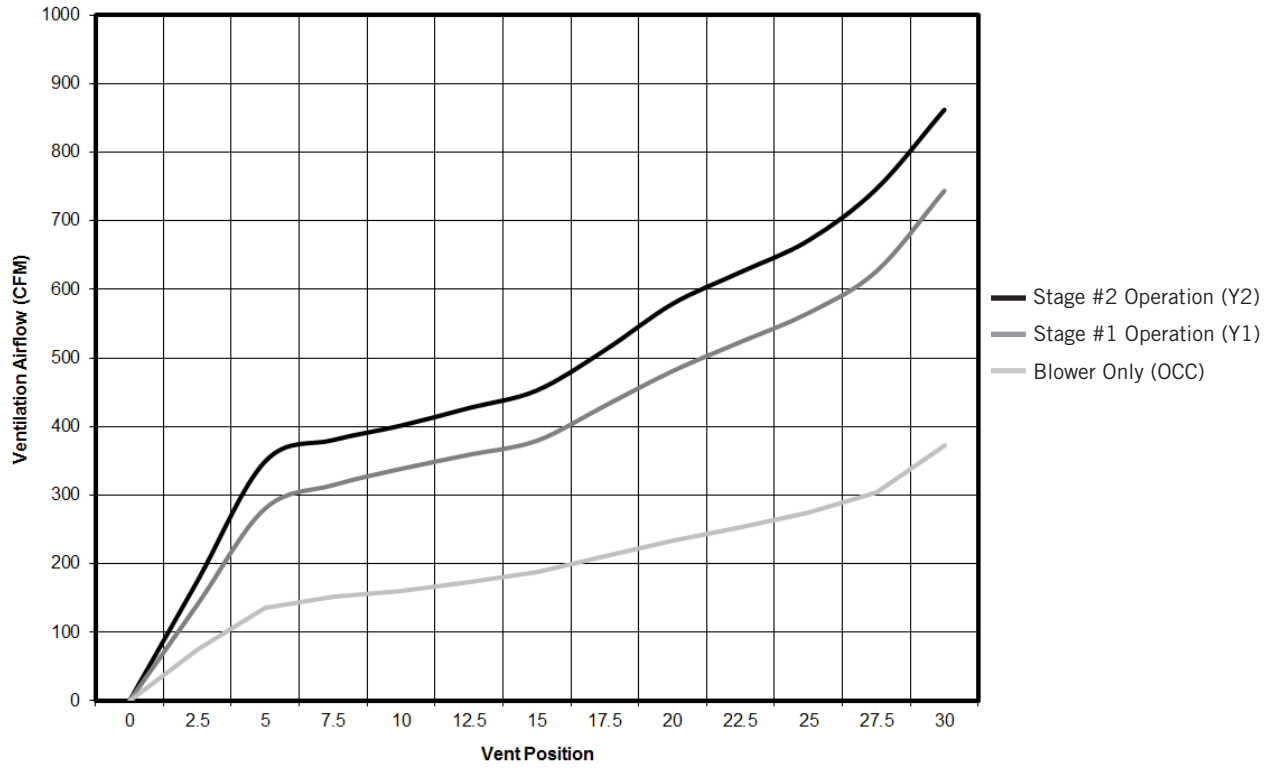

Adding Optional CO₂ Control Sensor

Adding an optional CO₂ control sensor (Bard Part #8403-096) to this control will maximize the capabilities of this vent by only supplying fresh air intake to maintain CO₂ levels. This has multiple benefits.

- Minimizes ventilation load on structure as it only brings in what is required to maintain CO₂ levels thus lowering reconditioning requirements (not having to heat/cool as much outside air).
- Will self-adjust for various occupancy levels so that fresh air is not being brought in beyond need. For example, if a room is designed for a maximum occupancy of 40 persons (standard ventilation control would have to be set for that occupancy), but the room typically only contains 25 persons. This control will self-adjust the amount of fresh air intake from 600 to 375 CFM automatically (based upon 15 CFM per person standard rate to ASHRAE standards).

Basic Installation

1. Make sure power is turned off to the unit
2. Follow steps beginning on page 4 for installation for standard control and vent assembly, then proceed with the following steps.
3. Run four (4) wire thermostat wire from the unit to the desired CO₂ sensor location.
4. Follow Figure 7 to configure the CO₂ sensor for proper operation.
5. Connect the thermostat wiring from the CO₂ sensor to step control assembly following the wiring diagram in Figure 10 on page 18 or the one on the ventilator assembly.
6. To check operation, restore power to the unit.
7. Make sure that thermostatic control is in “occupied” mode of operation calling for ventilation. Terminal “A” on the low voltage terminal strip must be energized to open damper.
8. Have someone stand in front of the CO₂ sensor and breathe on it. The display should show an increase in CO₂ ppm, and the damper blade in the ventilation package should increase. (It may be best to have two people to do this—one to breathe on control and one to observe damper.)

FIGURE 7
8403-096 CO₂ Sensor Set Up

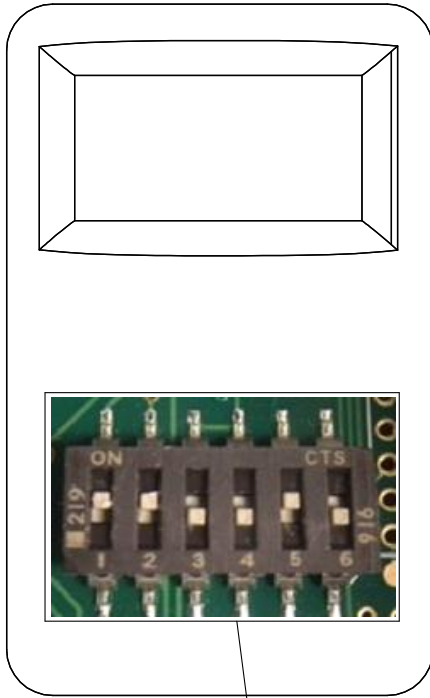

PRESS UP AND DOWN ARROWS TO ENTER CONFIGURATION MODE. USE ARROWS TO SELECT SETTING. PUSH MIDDLE BUTTON TO CHANGE. CONTROLLER WILL SHOW SET.

NOTE: MENU DIP SWITCH MUST BE IN "ON" POSITION #5 TO CHANGE ANY SETTINGS WITH THE SIDE BUTTONS. TO LOCK THE CO2 CONTROLLER MOVE DIP SWITCH TO "OFF" AFTER IT HAS BEEN CONFIGURED.

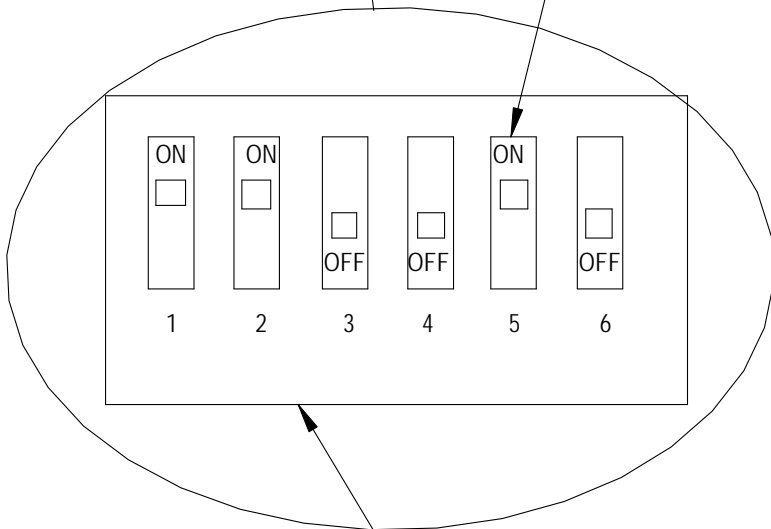
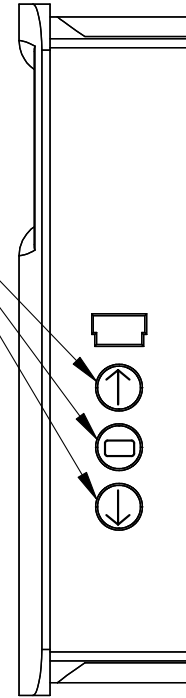

DIP SWITCHES MUST BE POSITIONED AS SHOWN FOR PROPER OPERATION

Settings	Recommended	Default
RON (RELAY ON SET POINT)	725	
ROF (RELAY OFF SET POINT)	700	
DSP (DISPLAY CONFIGURATION)	C	CT
UNI (UNITS SELECTION)	US	US
COL (CO2 LOW OUTPUT RANGE)	700	0
COH (CO2 HIGH OUTPUT RANGE)	1500	2000
TOL (TEMP. LOW OUTPUT RANGE)	Not Used	
TOH (TEMP. HIGH OUTPUT RANGE)	Not Used	
BAR (BAROMETRIC PRESSURE)	See Instructions with Controller For High Altitude Installations	
CAL (CALIBRATION)	Used for Field Calibration	

MIS-4025 C

Commercial Room Ventilator – WG*S Series

Features

- One piece construction—easy to install with no mechanical linkage adjustment required.
- Exhaust air damper built in with positive closed position. Provides exhaust air capability to prevent pressurization of tight buildings.
- Actuator motor: 24 volt, power open, spring return with built in torque limiting switch.
- Provides up to 75% of outside air.

Commercial Room Ventilator Sequence of Operation

On a call for blower operation, CRV opens to a position as set by step control position assembly (see Figure 8).

FIGURE 8
Call for Blower Operation

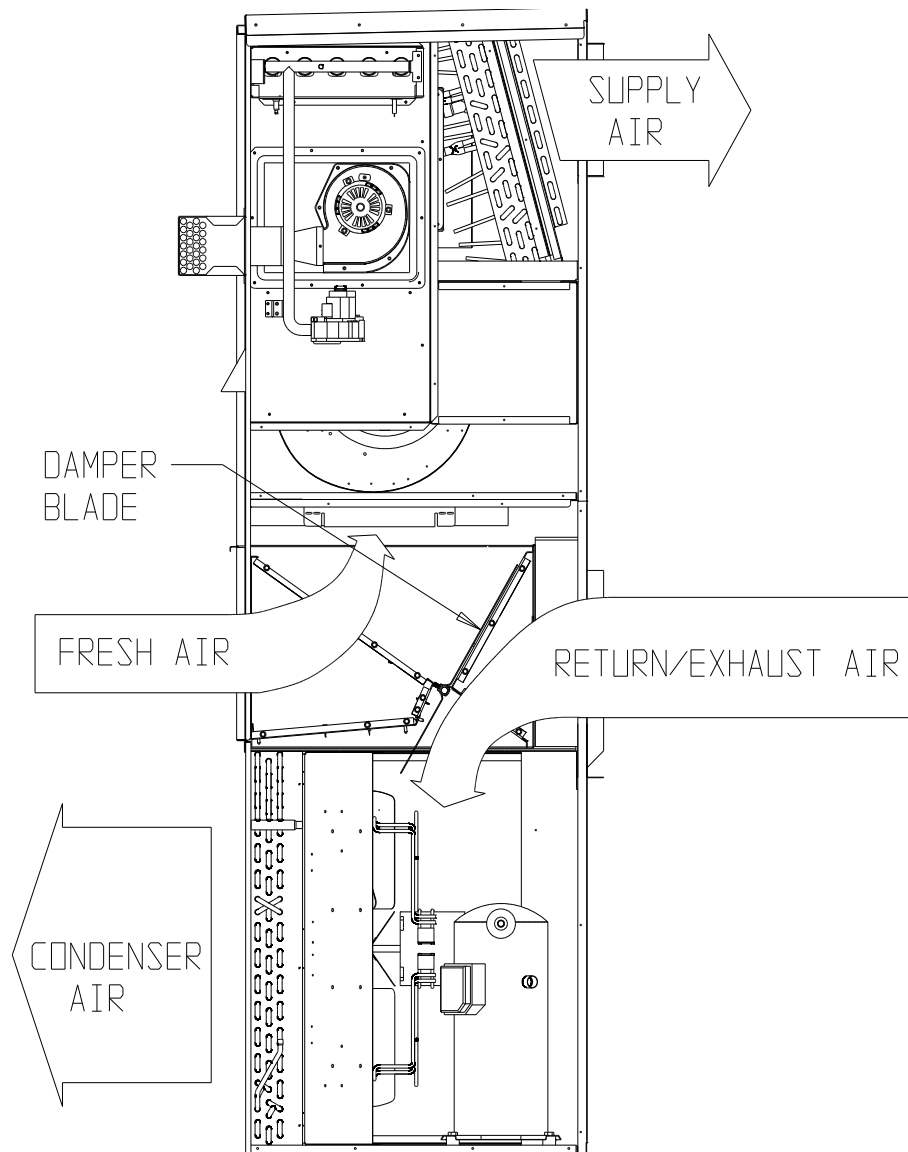

MIS-2413 A

A call for cooling cycles the compressor, and dampers remain in the ventilation mode. On loss of blower operation, CRV closes fully (see Figure 9).

FIGURE 9
Call for Cooling Operation

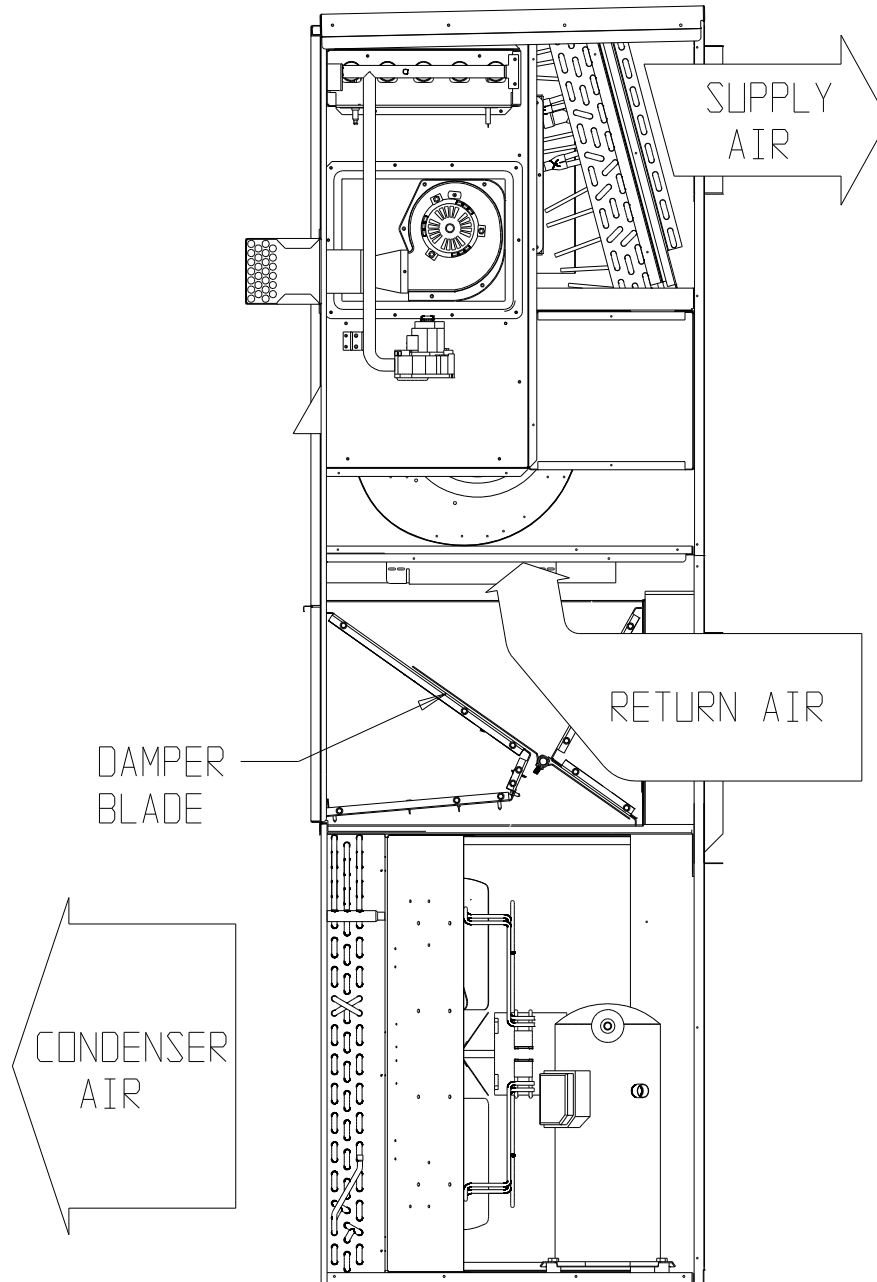

MIS-2412 A

FIGURE 10
Low Voltage Wiring – Multi-Position Commercial Room Ventilator

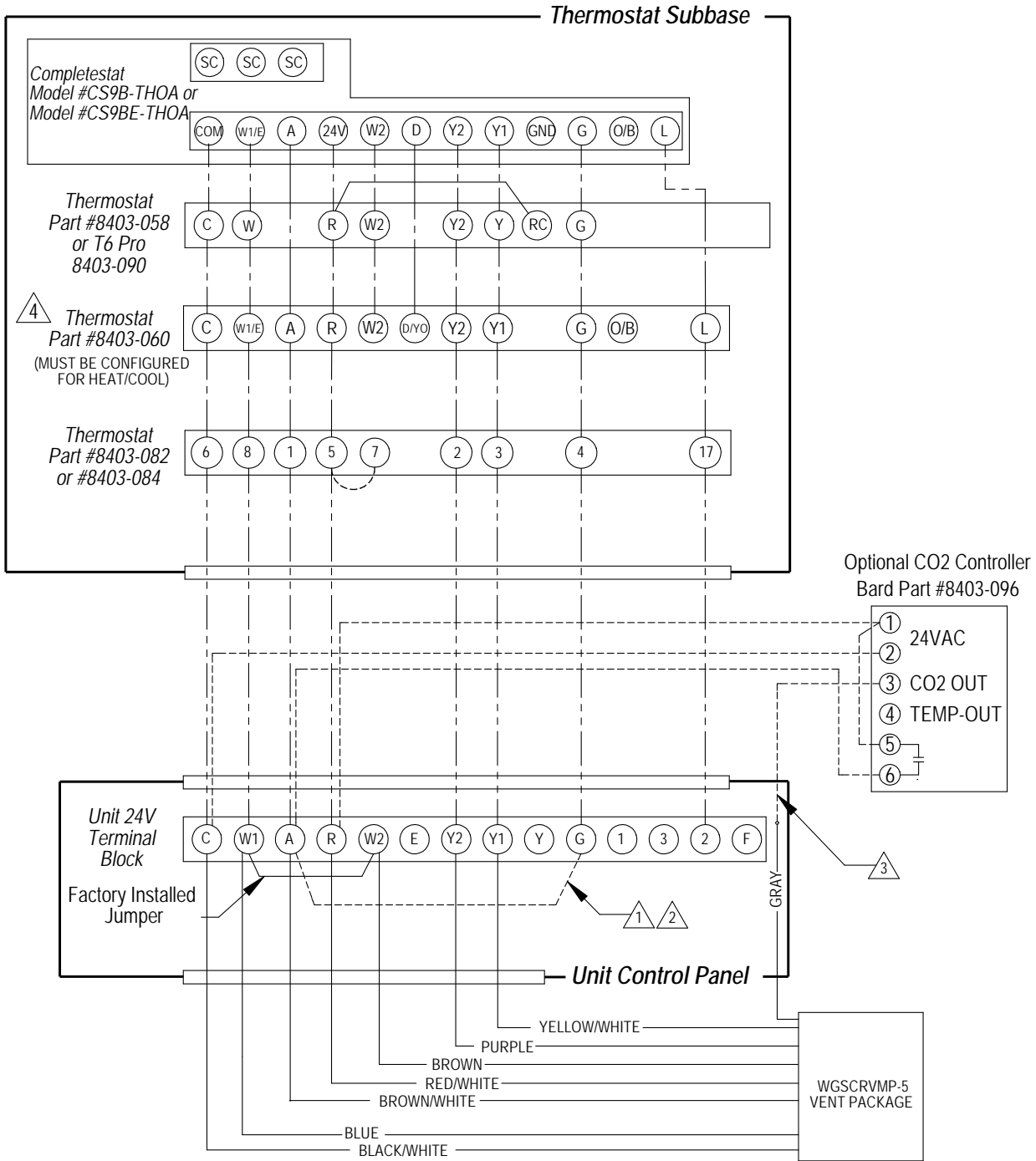

- ⚠️ 1 MUST INSTALL JUMPER FOR 8403-058 OR OTHER THERMOSTAT THAT DOES NOT HAVE OCCUPANCY OUTPUT.
- ⚠️ 2 INSTALL IF YOU REQUIRE VENTILATION ANYTIME BLOWER IS ON.
- ⚠️ 3 0-10 VDC MODULATING CO2 CONTROL SIGNAL FOR MODULATING VENTILATION CONTROL (OPTIONAL - SEE VENT INSTRUCTION MANUALS)
- ⚠️ 4 FOR VENT OPERATION STAT MUST BE CONFIGURED FOR PROGRAMMABLE, EVENTS PER DAY MUST BE 2 BUSINESS, AND FAN MUST BE SET TO PROGRAMMED FAN. THE BLOWER AND VENT WILL OPERATE DURING OCCUPIED PERIOD

MIS-4333 A