INSTALLATION INSTRUCTIONS

11EER Q-TEC™ Q**AFD Series Packaged Air Conditioner

Models:

Q36AFDA	Q42AFDA	Q48AFDA
Q36AFDB	Q42AFDB	Q48AFDB
Q36AFDC	Q42AFDC	Q48AFDC



Bard Manufacturing Company, Inc.
Bryan, Ohio 43506
www.bardvac.com

Manual: 2100-837
Supersedes: **NEW**
Date: 12-9-24

CONTENTS

Safety Instructions 4

Getting Other Information and Publications 12

Q-TEC™ General Information 13

Q-TEC Model Nomenclature 13
 Shipping Damage..... 13
 Unit Removal from Skid..... 14
 Handling Unit after Removal from Skid 15
 General 15
 Minimum Installation Height..... 16
 Duct Work 17
 Filters 17
 Switching Filter Sizes 18
 Fresh Air Intake..... 18
 Vent Options 18
 Barometric Fresh Air Damper (Standard) 18
 Commercial Room Ventilator (Option)..... 19
 Q-TEC Energy Recovery Ventilator (Option) 19

Installation 20

Basic Installation Design and Application Planning .. 20
 Mounting the Unit..... 20
 Condensate Drain..... 22
 Optional Rear Drain Kits..... 23
 Indoor Ducted and Non-Ducted Applications..... 27
 Indoor Supply Airflow..... 27
 Indoor Return Airflow..... 27
 Ducted Applications..... 27
 Free Blow Applications..... 27
 Thermostat or Indoor Temperature Sensor
 Placement 27
 Wiring – Main Power..... 29
 High Voltage Connections 29
 Wiring – Low Voltage 30
 Low Voltage Connections 30
 Unit Shutdown Feature 30
 Balanced Climate™ Feature..... 30
 Dehumidification Feature 30
 Ventilation Features 30
 Low Ambient Control..... 30
 Freeze Protection Thermostat 31

Start Up 34

General 34
 Topping Off System Charge 34
 Safety Practices..... 34
 Vent Connection Plug 34
 Pressure Service Ports 35
 Important Installer Notes 35
 Dehumidification Models..... 35
 Service Hints..... 35
 High and Low Pressure Switches 35
 Pressure Switch Lockout 35
 Three Phase Scroll Compressor Start Up
 Information 35
 Compressor Control Logic Board 35
 Over and Under Voltage Protection 36
 Intelligent Reset..... 36
 Alarm Output 36
 High Pressure Switch and Lockout Sequence .. 36

Troubleshooting Compressor Logic Control
 Board 36
 High Pressure Switch 36
 Low Pressure Switch 36
 Freeze Stat Switch 37
 Logic Control Board..... 37
 Phase Monitor 37
 Refrigerant Leak Detection System (RDS)..... 37
 Condenser Fan Operation..... 38
 Sequence of Operation 38
 Balanced Climate™ Mode..... 38

Troubleshooting 39

Troubleshooting ECM 142R Outdoor Fan Motors..... 39
 Replacing the Motor 40
 Troubleshooting ECM Indoor Blower Motors 41
 Replacing ECM Control Module..... 42
 Fan Blade Setting Dimensions..... 45
 R-454B Refrigerant Charge..... 45
 Removal of Fan Shroud..... 45
 Refrigerant Leak Detection System (RDS)..... 47
 Why RDS?..... 46
 Sequence of Operations 48
 Power Up and Self Test 48
 Normal Operation..... 48
 Alarm State 48
 Sensor Fault Mode 48
 Mitigation Mode 48
 Alarm Reset..... 48
 RDS Diagnosis 48
 Sensor End-of-Life..... 48

TABLES

Table 1 Wall Thermostats 31
 Table 2 Humidity Controls 31
 Table 3 CO₂ Controllers 31
 Table 4 Thermostat Wire Size..... 31
 Table 5 Troubleshooting ECM 142R Outdoor
 Fan Motors..... 40
 Table 6 Troubleshooting ECM Blower Motors 44
 Table 7 Fan Blade Dimensions..... 45
 Table 8A Cooling Pressure – Standard Airflow..... 46
 Table 8B Cooling Pressure – Balanced Climate
 Airflow 46
 Table 9 Electrical Specifications Q**AFD Series..... 51
 Table 10 Indoor Blower Performance 52
 Table 11 Maximum ESP Electric Heat Only..... 52
 Table 12 Electric Heat 52

FIGURES

Figure 1 Air Seal Under Q-TEC Unit..... 14
 Figure 2 Removal of Q-TEC Unit from Skid..... 14
 Figure 3 Fan Assembly Removal 15
 Figure 4 Q-TEC Unit on Appliance Cart 15
 Figure 5 Installation with Duct-Free Plenum 16
 Figure 6 Ducted Application 16
 Figure 7 Supply Duct Connections..... 17
 Figure 8 Filter Location 17
 Figure 9 Filter Tabs in Up Position..... 18

Figure 10	Bend Filter Tabs Down	18
Figure 11	Fresh Air Damper Assembly	18
Figure 12	Remove Compressor Shipping Brackets....	20
Figure 13A	Unit Mounting – Method 1	21
Figure 13B	Unit Mounting – Method 2.....	21
Figure 14	Remove Locking Screws from Wheels.....	22
Figure 15	Optional Side Drain (Side View).....	22
Figure 16	Standard Rear Drain.....	22
Figure 17	Rear Drain (Top View)	23
Figure 18A	24
Figure 18B	24
Figure 18C	25
Figure 18D	26
Figure 19	Unit Dimensions	28
Figure 20	High Voltage Connections	29
Figure 21	Thermostat Connections	32
Figure 22	Thermostat Connections	33
Figure 23	Compressor Logic Control Board	36
Figure 24	LED Fault Illumination.....	37
Figure 25	Control Disassembly	43
Figure 26	Winding Test.....	43
Figure 27	Drip Loop.....	43
Figure 28	Control Connector Motor Half	44
Figure 29	Fan Blade Setting	45
Figure 30	Fan Shroud Removal	45
Figure 31	Refrigerant Leak Detection System	47
Figure 32	Sensor Status LED Blink Code.....	48
Figure 33	Refrigerant Leak Detection System (RDS) Troubleshooting	49
Figure 34	Refrigerant Leak Detection System (RDS) Wiring Diagram	50

GRAPHS

Graph 1	Q36AFD FAD Ventilation Delivery	53
Graph 2	Q42AFD FAD Ventilation Delivery	53
Graph 3	Q48AFD FAD Ventilation Delivery	54

SAFETY INSTRUCTIONS

READ ALL INSTRUCTIONS BEFORE USE

Your safety and the safety of others are very important.

We have provided many important safety messages in this manual and on your appliance. Always read and follow all safety messages.

ANSI Z535.5 Definitions:

DANGER: Indicate[s] a hazardous situation which, if not avoided, will result in death or serious injury. The signal word “DANGER” is to be limited to the most extreme situations. DANGER [signs] should not be used for property damage hazards unless personal injury risk appropriate to these levels is also involved.

WARNING: Indicate[s] a hazardous situation which, if not avoided, could result in death or serious injury. WARNING [signs] should not be used for property damage hazards unless personal injury risk appropriate to this level is also involved.

CAUTION: Indicate[s] a hazardous situation which, if not avoided, could result in minor or moderate injury. CAUTION [signs] without a safety alert symbol may be used to alert against unsafe practices that can result in property damage only.

NOTICE: [this header is] preferred to address practices not related to personal injury. The safety alert symbol shall not be used with this signal word. As an alternative to “NOTICE” the word “CAUTION” without the safety alert symbol may be used to indicate a message not related to personal injury.

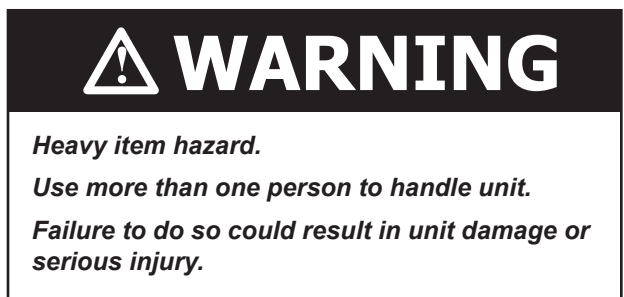
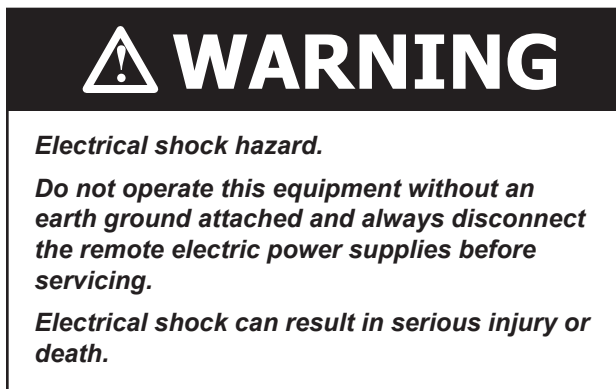
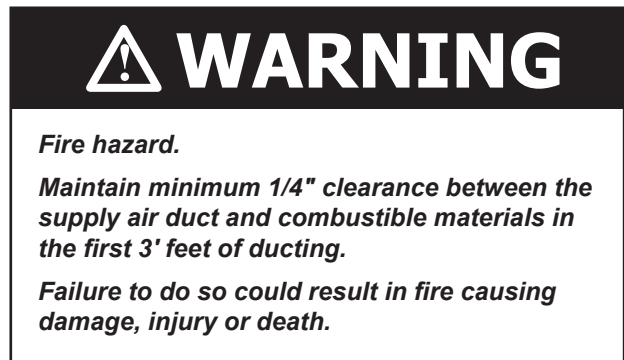

WARNING

Electrical shock hazard.

Have a properly trained individual perform these tasks.

Failure to do so could result in electric shock or death.

CAUTION

Sharp metallic edges.

Take care and wear appropriate protective devices to avoid accidental contact with sharp edges.

Failure to do so can result in personal injury.

WARNING

Do not use means to accelerate the defrosting process or to clean, other than those recommended by the manufacturer.

This appliance shall be stored in a room without continuously operating ignition sources (for example: open flames, an operating gas appliance or an operating electric heater.)

WARNING

Do not pierce or burn through copper.

Be aware that the refrigerant used in system may not contain an odor.

Ducts connected to appliance shall not contain a POTENTIAL IGNITION SOURCE.

The following symbols are displayed on units.



This symbol indicates that the unit contains a mildly flammable refrigerant.

Refrigerant
Safety Group
A2L

This symbol indicates that the refrigerant used is classified as an A2L, or mildly flammable refrigerant.



This symbol indicates that the Operation Manual should be read carefully.



This symbol indicates that a service personnel should be handling this equipment with reference to the Installation Manual.



This symbol indicates that information is available such as the Operation Manual or Installation Manual.

IMPORTANT SAFETY INSTRUCTIONS



WARNING

To reduce the risk of explosion, fire, death, electric shock, scalding or injury to persons when using this product, follow basic precautions, including the following:

GENERAL

- The equipment covered in this manual is to be installed by trained, experienced service and installation technicians.
- This appliance is not intended for use by persons (including children) with reduced physical, sensory or mental capabilities, or lack of experience and knowledge, unless they have been given supervision or instruction concerning use of the appliance by a person responsible for their safety.
- The refrigerant system is completely assembled and charged. All internal wiring is complete.
- The unit is designed for use with or without duct work. Flanges are provided for attaching the supply and return ducts.
- These instructions explain the recommended method to install the air-cooled self-contained unit and the electrical wiring connections to the unit.
- These instructions and any instructions packaged with any separate equipment required to make up the entire air conditioning system should be carefully read before beginning the installation. Note particularly “Starting Procedure” and any tags and/or labels attached to the equipment.
- While these instructions are intended as a general recommended guide, they do not supersede any national and/or local codes in any way. Authorities having jurisdiction should be consulted before the installation is made. See Additional Publications for information on codes and standards.
- Size of unit for a proposed installation should be based on heat loss calculation made according to methods of Air Conditioning Contractors of America (ACCA). The air duct should be installed in accordance with the Standards of the National Fire Protection Association for the Installation of Air Conditioning and Ventilating Systems of Other Than Residence Type, NFPA No. 90A, and Residence Type Warm Air Heating and Air Conditioning Systems, NFPA No. 90B. Where local regulations are at a variance with instructions, installer should adhere to local codes.

INSTALLATION

- For appliances intended for use at altitudes exceeding 2,000 meters (6,562 feet), the maximum altitude of use shall be stated.
- Before use, the appliance must be properly installed as described in this manual.
- Contact the authorized service technician for repair or maintenance of this unit.
- Contact the installer for installation of this unit.
- The air conditioner is not intended for use by young children or invalids without supervision.
- Young children should be supervised to ensure that they do not play with the air conditioner.
- Installation work must be performed in accordance with the National Electric Code by qualified and authorized personnel only.
- Connect to a properly rated, protected, and sized power circuit to avoid electrical overload.
- Adhere to all industry recommended safety procedures including the use of long-sleeved gloves and safety glasses.
- Use care when unpacking and installing. The edges of the product may be sharp.
- Keep packaging materials out of the reach of children. These materials can pose a suffocation risk to children.
- Auxiliary devices which may be a POTENTIAL IGNITION SOURCE shall not be installed in the duct work. Examples of such POTENTIAL IGNITION SOURCES are hot surfaces with a temperature exceeding 700°C and electric switching devices.

IMPORTANT SAFETY INSTRUCTIONS



WARNING

OPERATION

- This appliance is not intended for use by persons (including children) with reduced physical, sensory, or mental capabilities, or lack of experience and knowledge, unless they have been given supervision or instruction concerning use of the appliance by a person responsible for their safety.
- Use this appliance only for its intended purpose.
- Never attempt to operate this appliance if it is damaged, malfunctioning, partially disassembled, or has missing or broken parts.
- Do not tamper with controls.
- Keep all required ventilation openings clear of obstructions.
- Ducts connected to an appliance shall not contain a POTENTIAL IGNITION SOURCE.

INSTRUCTIONS DE SÉCURITÉ

LIRE TOUTES LES INSTRUCTIONS AVANT UTILISATION

Votre sécurité et celle des autres sont très importantes.

Nous avons fourni de nombreux messages de sécurité importants dans ce manuel et sur votre appareil. Lisez et suivez toujours tous les messages de sécurité.

Définitions ANSI Z535.5 :

DANGER : Indique une situation dangereuse qui, si elle n'est pas évitée, entraînera certainement la mort ou des blessures graves. Le mot « DANGER » doit être limité aux situations extrêmes. Les indications « DANGER » ne doivent pas être utilisées pour les risques de dégâts matériels, à moins qu'il n'existe un risque concomitant de blessures corporelles.

AVERTISSEMENT : Indique une situation dangereuse qui, si elle n'est pas évitée, peut entraîner la mort ou des blessures graves. Les indications « AVERTISSEMENT » ne doivent pas être utilisées pour les risques de dégâts matériels, à moins qu'il n'existe un risque concomitant de blessures corporelles.

ATTENTION : Indique une situation dangereuse qui, si elle n'est pas évitée, peut entraîner des blessures mineures à modérées. Les indications « ATTENTION », sans symbole d'avertissement, peuvent être utilisées pour alerter sur des pratiques dangereuses pouvant entraîner des dégâts matériels uniquement.

REMARQUE : cet avis concerne les pratiques n'entraînant aucune blessure corporelle. Le symbole d'avertissement ne doit pas être utilisé avec ce mot. Comme alternative à « AVIS », le mot « ATTENTION » sans symbole d'avertissement peut être utilisé pour indiquer un message non lié à des blessures corporelles.



AVERTISSEMENT

Risque de choc électrique.

Ne pas faire fonctionner cet équipement sans qu'il soit relié à la terre et toujours débrancher les alimentations électriques avant de procéder aux opérations d'entretien.

Une électrisation peut entraîner des blessures graves ou la mort.

REMARQUE

APPAREIL ACCESSIBLE AU GRAND PUBLIC.

AVERTISSEMENT

Risque d'incendie.

Conserver un dégagement minimal de 6,35 mm/1/4 po entre le conduit d'air soufflé et les matériaux combustibles sur les 900 premiers millimètres (3 pi) du conduit.

Le non-respect de cette consigne entraîne des risques de dégâts matériels, de blessures corporelles ou de décès.

AVERTISSEMENT

Risque lié aux objets lourds.

Plusieurs personnes sont nécessaires à la manipulation de l'unité.

Le non-respect de cette consigne peut entraîner dégâts à l'unité ou des blessures graves.



AVERTISSEMENT

Risque de choc électrique.

Ces tâches doivent être réalisées par une personne parfaitement qualifiée et formée.

Le non-respect de cette consigne peut entraîner des chocs électriques ou la mort.



ATTENTION

Arêtes métalliques vives.

Faites attention et portez des dispositifs de protection appropriés pour éviter tout contact accidentel avec des arêtes vives.

Le non-respect de cette consigne peut entraîner des blessures corporelles.



AVERTISSEMENT

N'utilisez pas de moyens pour accélérer le processus de dégivrage ou pour nettoyer, autres que ceux recommandés par le fabricant.

Cet appareil doit être entreposé dans une pièce sans sources d'inflammation fonctionnant en continu (par exemple : flammes nues, un appareil à gaz en fonctionnement ou un appareil de chauffage électrique en fonctionnement).



AVERTISSEMENT

Ne percez pas ou ne brûlez pas à travers le cuivre.

Sachez que le réfrigérant utilisé dans le système peut ne pas contenir d'odeur.

*Les conduits raccordés à l'appareillage ne doivent pas contenir de **SOURCE D'INFLAMMATION POTENTIELLE**.*

Les symboles suivants sont affichés sur les unités.



Ce symbole indique que l'unité contient un réfrigérant légèrement inflammable.

Refrigerant
Safety Group
A2L

Ce symbole indique que le réfrigérant utilisé est classé comme réfrigérant A2L ou légèrement inflammable.



Ce symbole indique que le manuel d'utilisation doit être lu attentivement.



Ce symbole indique qu'un membre du personnel de service devrait manipuler cet équipement en se référant au manuel d'installation.



Ce symbole indique que des informations sont disponibles telles que le manuel d'utilisation ou le manuel d'installation.

INSTRUCTIONS DE SÉCURITÉ IMPORTANTES



AVERTISSEMENT

Pour réduire le risque d'explosion, d'incendie, de décès, de choc électrique, d'échaudure ou de blessures pour les personnes lors de l'utilisation de ce produit, suivez les précautions de base, notamment les suivantes :

GÉNÉRALITÉS

- L'équipement couvert dans ce manuel doit être installé par des techniciens de service et d'installation formés et expérimentés.
- Cet appareil n'est pas destiné à être utilisé par des personnes (y compris des enfants) ayant des capacités physiques, sensorielles ou mentales réduites, ou un manque d'expérience et de connaissances, à moins qu'elles n'aient reçu la supervision ou l'instruction concernant l'utilisation de l'appareil par une personne responsable de leur sécurité.
- Le système de réfrigérant est complètement assemblé et chargé. Tout le câblage interne est complet.
- L'unité est conçue pour être utilisée avec ou sans conduits. Des brides sont prévues pour fixer les conduits d'alimentation et de retour.
- Ces instructions expliquent la méthode recommandée pour installer l'unité autonome refroidie à l'air et les connexions de câblage électrique à l'unité.
- Ces instructions et toutes les instructions emballées avec tout équipement distinct requis pour constituer l'ensemble du système de climatisation doivent être lues attentivement avant de commencer l'installation. Notez en particulier « Procédure de démarrage » et les étiquettes et / ou étiquettes attachées à l'équipement.
- Bien que ces instructions soient conçues comme un guide général recommandé, elles ne remplacent en aucune façon les codes nationaux et/ou locaux. Les autorités compétentes devraient être consultées avant que l'installation ne soit effectuée. Voir d'autres publications pour obtenir des renseignements sur les codes et les normes.
- La taille de l'unité pour une installation proposée devrait être basée sur le calcul de la perte de chaleur effectué selon les méthodes de Air Conditioning Contractors of America (ACCA). Le conduit d'air devrait être installé conformément aux Normes de la National Fire Protection Association for the Installation of Air Conditioning and Ventilating Systems of Other Than Residence Type, NFPA No. 90A, et aux Systèmes de chauffage et de climatisation d'air chaud de type résidence, NFPA No. 90B. Lorsque les réglementations locales sont en contradiction avec les instructions, l'installateur doit respecter les codes locaux.

L'INSTALLATION

- Pour les appareils destinés à être utilisés à des altitudes supérieures à 2 000 mètres (6 562 pieds), l'altitude maximale d'utilisation doit être indiquée.
- Avant utilisation, l'apppliance doit être correctement installée comme décrit dans ce manuel.
- Communiquez avec le technicien d'entretien autorisé pour la réparation ou l'entretien de cette unité.
- Contactez le programme d'installation pour l'installation de cet appareil.
- Le climatiseur n'est pas destiné à être utilisé par de jeunes enfants ou des invalides sans surveillance.
- Les jeunes enfants devraient être surveillés pour s'assurer qu'ils ne jouent pas avec le climatiseur.
- Les travaux d'installation doivent être effectués conformément au Code national de l'électricité par du personnel qualifié et autorisé uniquement.
- Connectez-vous à un circuit d'alimentation correctement évalué, protégé et dimensionné pour éviter les surcharges électriques.
- Respectez toutes les procédures de sécurité recommandées par l'industrie, y compris l'utilisation de gants à manches longues et de lunettes de sécurité.
- Faites attention lors du déballage et de l'installation. Les bords du produit peuvent être tranchants.
- Gardez les matériaux d'emballage hors de la portée des enfants. Ces matériaux peuvent poser un risque d'étouffement pour les enfants.
- Les dispositifs auxiliaires qui peuvent être une SOURCE D'INFLAMMATION POTENTIELLE ne doivent pas être installés dans les conduits. Des exemples de telles SOURCES D'INFLAMMATION POTENTIELLES sont les surfaces chaudes dont la température dépasse 700 °C et les dispositifs de commutation électrique.

INSTRUCTIONS DE SÉCURITÉ IMPORTANTES



AVERTISSEMENT

OPÉRATION

- Cet appareil n'est pas destiné à être utilisé par des personnes (y compris des enfants) ayant des capacités physiques, sensorielles ou mentales réduites, ou un manque d'expérience et de connaissances, à moins qu'elles n'aient reçu une supervision ou une instruction concernant l'utilisation de l'appareil par une personne responsable de leur sécurité.
- Utilisez cet appareil uniquement aux fins prévues.
- N'essayez jamais de faire fonctionner cet appareil s'il est endommagé, défectueux, partiellement démonté ou s'il a des pièces manquantes ou cassées.
- Ne pas altérer les contrôles.
- Gardez toutes les ouvertures de ventilation nécessaires à l'écart des obstacles.
- Les conduits raccordés à un appareil ne doivent pas contenir de SOURCE D'INFLAMMATION POTENTIELLE.

GETTING OTHER INFORMATION AND PUBLICATIONS

These publications can help when installing the air conditioner. They can usually be found at the local library or purchased directly from the publisher. Be sure to consult the current edition of each standard.

National Electrical Code	ANSI/NFPA 70
Standard for the Installation of Air Conditioning and Ventilating Systems	ANSI/NFPA 90A
Standard for Warm Air Heating and Air Conditioning Systems	ANSI/NFPA 90B
Load Calculation for Winter and Summer Air Conditioning	ACCA Manual J Residential
Duct Design for Residential Winter and Summer Air Conditioning and Equipment Selection	ACCA Manual D

For more information, contact these publishers:

ACCA	Air Conditioning Contractors of America 1712 New Hampshire Ave. N.W. Washington, DC 20009 Telephone: (202) 483-9370 Fax: (202) 234-4721
ANSI	American National Standards Institute 11 West Street, 13th Floor New York, NY 10036 Telephone: (212) 642-4900 Fax: (212) 302-1286
ASHRAE	American Society of Heating, Refrigeration and Air Conditioning Engineers, Inc. 1791 Tullie Circle, N.E. Atlanta, GA 30329-2305 Telephone: (404) 636-8400 Fax: (404) 321-5478
NFPA	National Fire Protection Association Batterymarch Park P.O. Box 9101 Quincy, MA 02269-9901 Telephone: (800) 344-3555 Fax: (617) 984-7057

WARNING

Electrical shock hazard.
Disconnect the remote electric power supply or supplies before servicing.
Failure to do so can result in serious injury or death.

WARNING

Exposed moving parts.
Disconnect all electrical power before servicing.
Failure to do so can result in severe injury or amputation.

WARNING

Heavy item hazard.
Use more than one person to handle unit.
Check unit wheels to ensure that wheels are locked before removing from skid.
Failure to do so could result in unit damage or serious injury.

Q-TEC GENERAL INFORMATION

Q-TEC Model Nomenclature

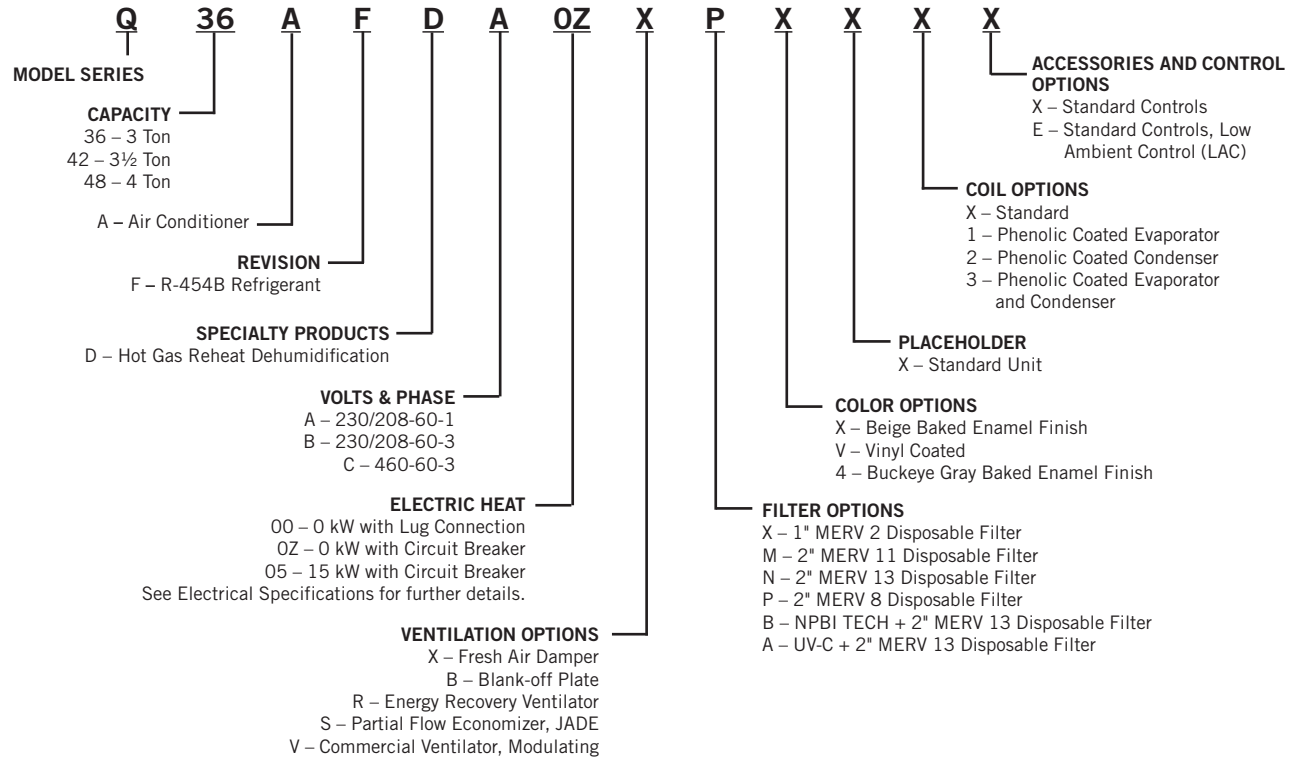

Shipping Damage

Upon receipt of equipment, the carton should be checked for external signs of shipping damage. The skid must remain attached to the unit until the unit is ready for installation. If damage is found, the receiving party must contact the last carrier immediately, preferably in writing, requesting inspection by the carrier's agent.

Unit Removal from Skid

It is **not** recommended that the unit be removed from the skid with a fork lift as the air seal under the unit could be damaged (see Figure 1).

The shipping brackets on each side of the unit must be removed and discarded (see Figure 2). The return air grille panel can be removed to provide a place to hold the unit.

The unit can be tipped forward and slid down the edge of the skid until the front wheels touch the ground. The wheels will not roll as they are shipped from the factory locked. The back of the skid will have to be held down to keep it from tipping up. The skid can be slid out from under the unit. The unit can then be set upright.

FIGURE 1
Air Seal Under Q-TEC Unit

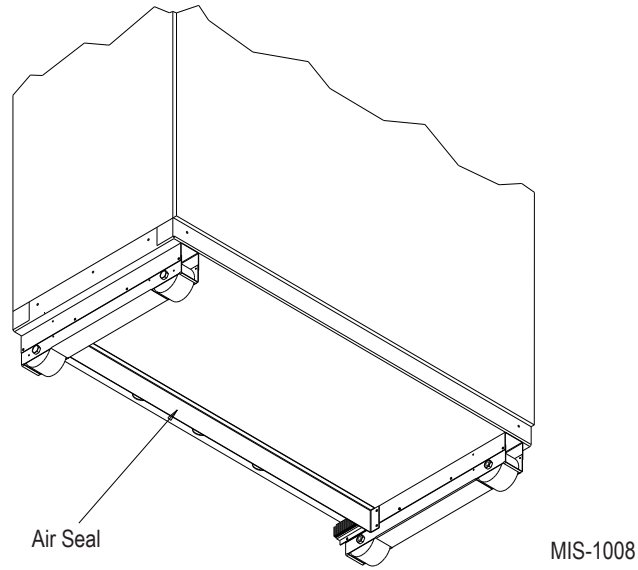
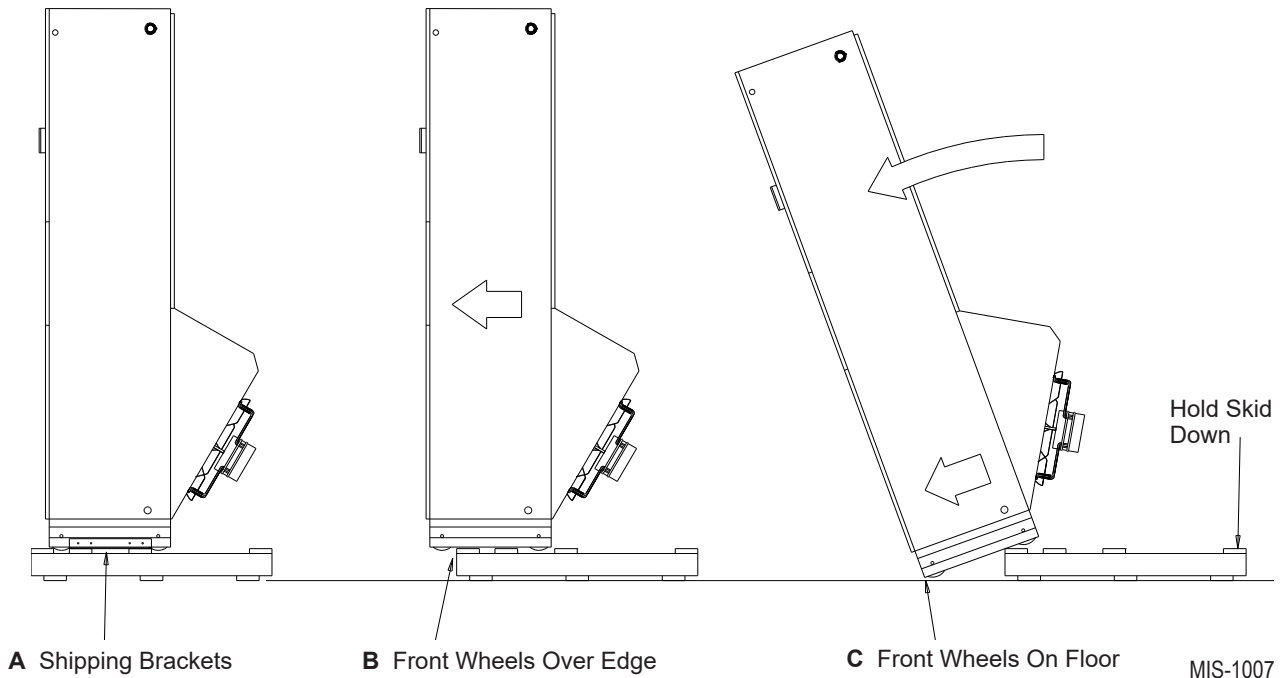
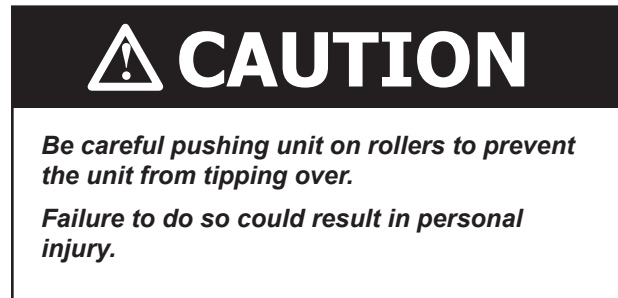

FIGURE 2
Removal of Q-TEC Unit from Skid



Handling Unit after Removal from Skid



The unit will have to be turned sideways and removed from skid to fit through a doorway. If the door height allows, the unit can be slid sideways through the door. The fan assembly can be easily removed to reduce depth to 34" for fitting through 36" doorway (see Figure 3).

FIGURE 3
Fan Assembly Removal

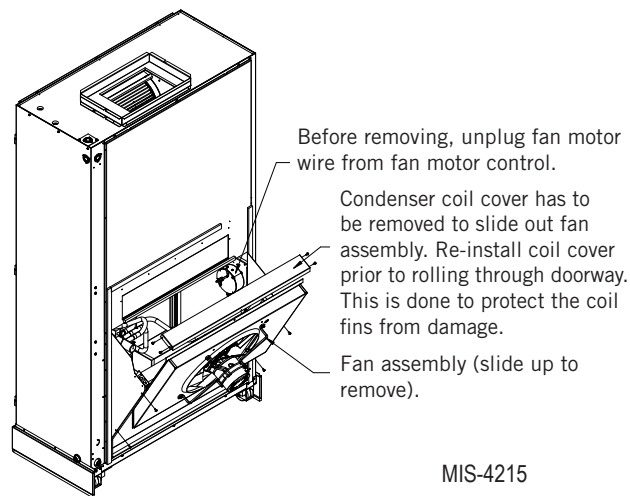

If the unit cannot be slid through the doorway, then the unit will have to be put on a appliance cart and tipped down to roll through the doorway. It is recommended that a strap be used hold the unit down on the cart. The wheels of the unit **must be locked**. If the wheels were allowed to roll, the unit could roll off the cart. **The unit should always be carted from the right side** which is the side where the compressor is located (see Figure 4).

The blade of the appliance cart should be slid under the wheels of the unit. The strap of the appliance cart should be placed around the unit and strapped tight. Help will be required to tip the unit back on to the cart. The unit can be leaned far enough back to be rolled through the doorway. Be careful when setting the unit back up to keep from damaging the unit.

FIGURE 4
Q-TEC Unit on Appliance Cart

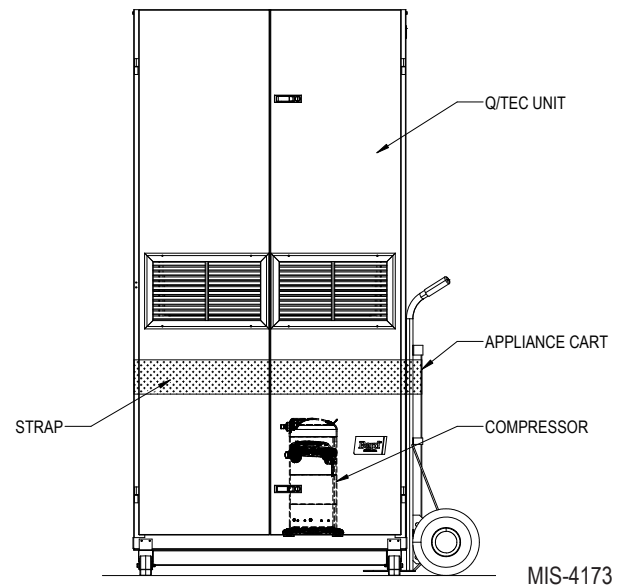

General

The equipment covered in this manual is to be installed by trained, experienced service and installation technicians.

A Q-TEC Series wall sleeve offered as a separate accessory must be ordered and installed with Q-TEC unit.

The unit is designed for use with or without duct work. For use without duct work, Plenum Box QPB36 is recommended.

These instructions explain the recommended method to install the air cooled self-contained unit and the electrical wiring connections to the unit.

These instructions and any instructions packaged with any separate equipment required to make up the entire air conditioning system should be carefully read before beginning the installation. Note particularly "Start Procedure" and any tags and/or labels attached to the equipment.

While these instructions are intended as a general recommended guide, they do not supersede any national and/or local codes in any way. Authorities having jurisdiction should be consulted before the installation is made. See page 12 for information on codes and standards.

Size of unit for a proposed installation should be based on heat loss calculation made according to methods of Air Conditioning Contractors of America (ACCA). The air duct should be installed in accordance with the Standards of the National Fire Protection Systems of Other Than Residence Type, NFPA No. 90A, and Residence Type Warm Air Heating and Air Conditioning Systems, NFPA No. 90B. Where local regulations are at a variance with instructions, installer should adhere to local codes.

Minimum Installation Height

The minimum installation height of the unit with a free blow plenum is 8' 6". This provides enough clearance for the plenum to be removed (see Figure 5).

The minimum installation height for ducted applications is 8' 4-1/2". This provides enough clearance to install the duct work (see Figure 6).

FIGURE 5
Installation with Duct-Free Plenum

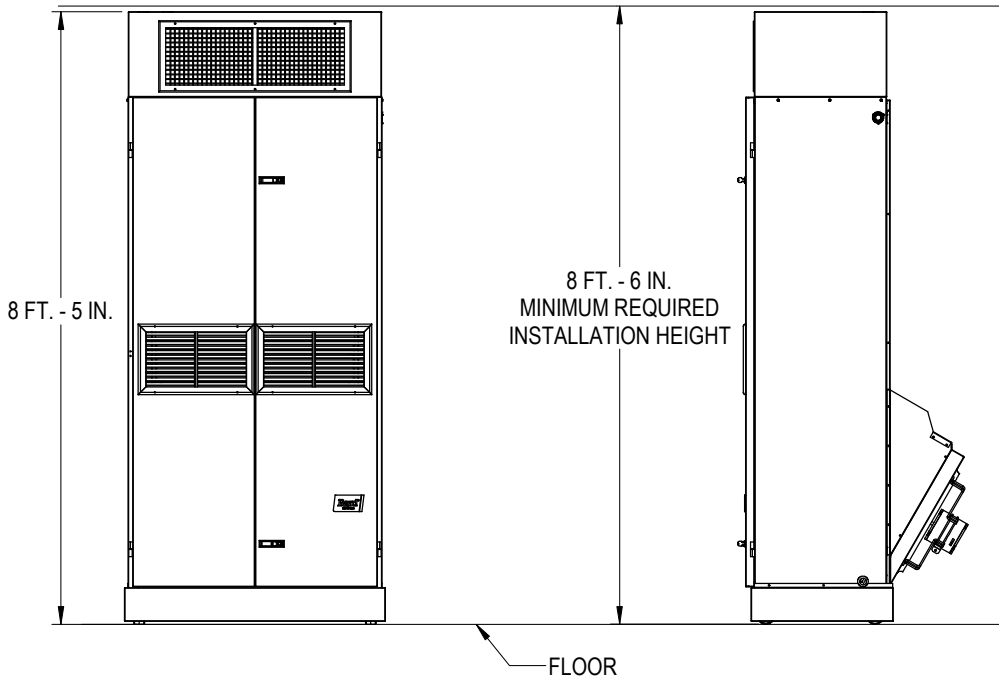

MIS-4174

FIGURE 6
Ducted Application

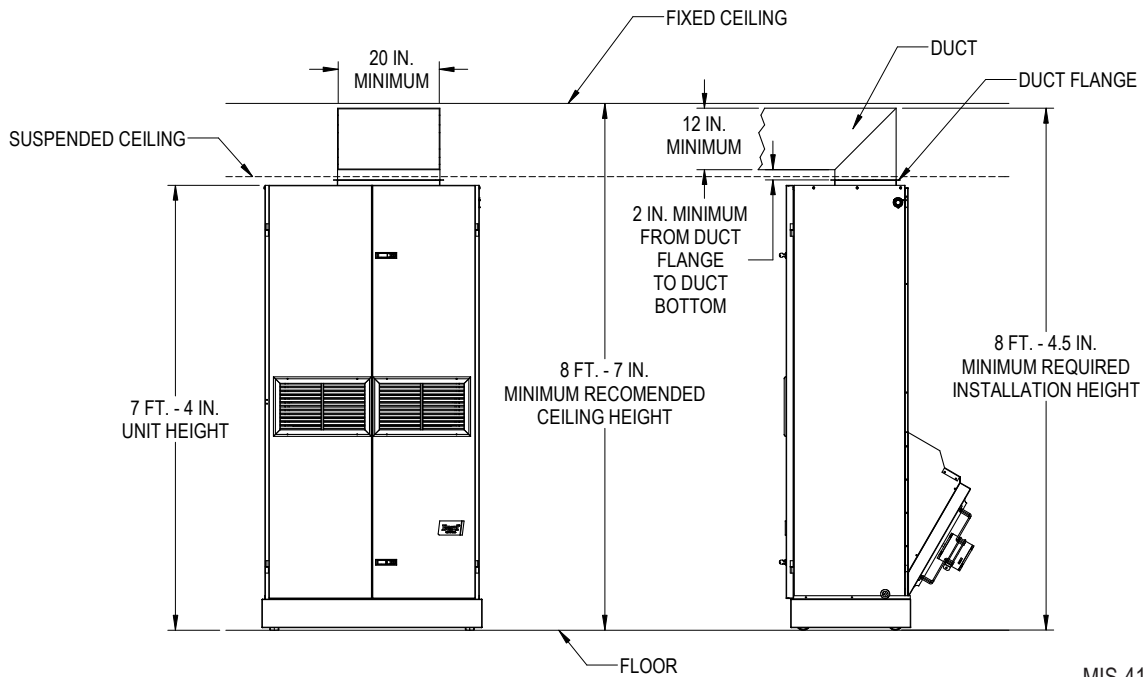

MIS-4175

Duct Work

All duct work must be properly sized for the design airflow requirement of the equipment. Air Conditioning Contractors of America (ACCA) is an excellent guide to proper sizing. All duct work or portions thereof not in the conditioned space should be properly insulated in order to both conserve energy and prevent condensation or moisture damage.

Refer to Maximum ESP of Operation – Electric Heat Only table on page 52.

Design the duct work according to methods given by the Air Conditioning Contractors of America (ACCA). When duct runs through unheated spaces, it should be insulated with a minimum of 1" of insulation. Use insulation with a vapor barrier on the outside of the insulation. Flexible joints should be used to connect the duct work to the equipment in order to keep the noise transmission to a minimum.

The Q-TEC series has provision to attach a supply air duct to the top of the unit. Duct connection size is 12" x 20". The duct work is field supplied and must be attached in a manner to allow for ease of removal when it becomes necessary to slide the unit out from the wall for service. See Figure 7 for suggested attachment method.

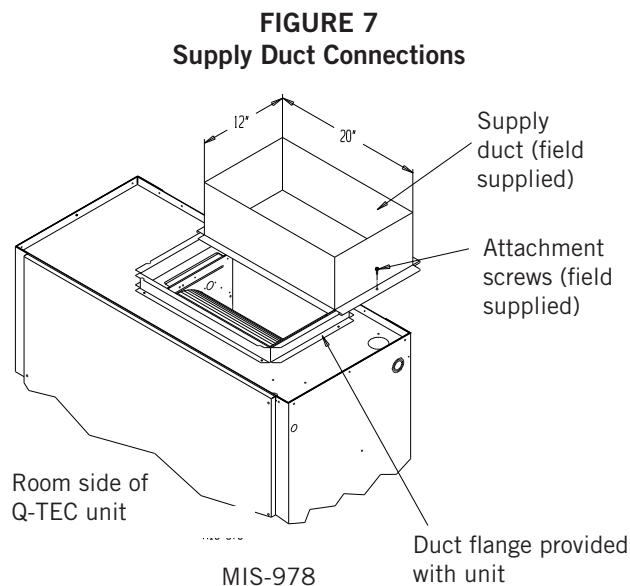

NOTE: Unit cabinet, supply air duct and duct free plenum are approved for "0" clearance to combustible material.

The Q-TEC series are designed for use with free return (non-ducted) and either free blow with the use of QPB Plenum Box or a duct supply air system.

The QPB and QPBHW Plenum Box mounts on top of the unit and has both vertically and horizontally adjustable louvers on the front discharge grille.

For hot water coil option, a QPBHW**-F for free blow or QPBHW**-D for ducted airflow is used.

When used with a ducted supply, a Q4CX Cabinet Extension can be used to conceal the duct work above the unit to the ceiling. This extends 20" above the unit for a total height above the floor of 10'-7/8". The unit is equipped with a variable speed indoor blower motor which increases in speed with an increase in duct static pressure. The unit will therefore deliver proper rated air flow up to the maximum ESP shown in Table 11 on page 52. However, for quiet operation of the air system, the duct static should be kept as low as practical, within the guidelines of good duct design.

Filters

The filters can be serviced from the front by opening the hinged main doors (see Figure 8). Two (2) 1" throwaway filters come standard with each unit. Additional 1" and 2" filter options are available as optional accessories.

NOTE: When installing new filters, make sure that airflow arrows on filters point up.

FIGURE 8
Filter Location

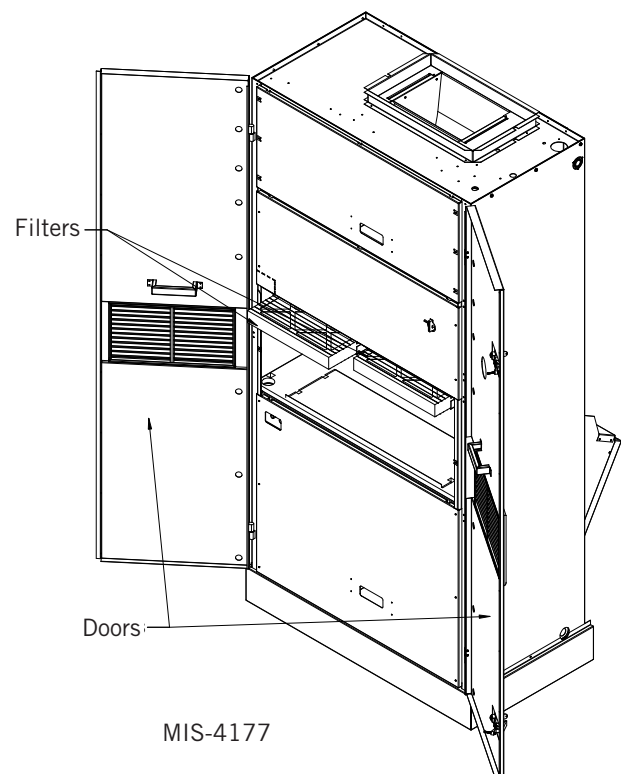

Switching Filter Sizes

To switch from 1" to 2" filters, remove the filter slide and bend the tabs down out of the way to accommodate the 2" filter (see Figures 9 and 10).

FIGURE 9
Filter Tabs in Up Position

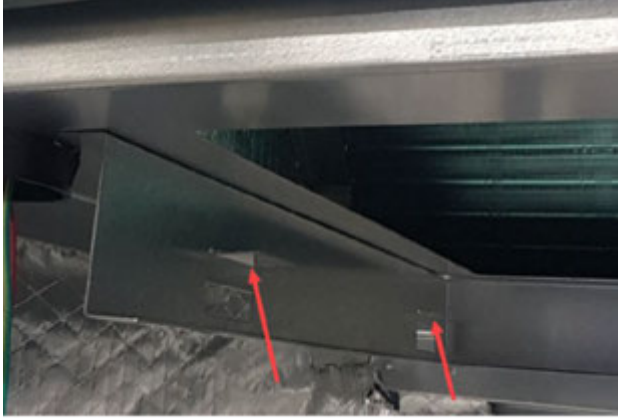

FIGURE 10
Bend Filter Tabs Down



Fresh Air Intake

This unit may be equipped with a fresh air damper assembly. The damper blade is locked in the closed position when the unit is shipped from the factory. To allow the damper to operate, remove the two plastic locking pins, one on each end of the blade. This will allow for maximum fresh airflow. The damper blade will now open when the indoor blower is operating. If less than maximum fresh airflow is required, re-insert the plastic pins to limit damper blade opening to desired level. Two extra pins are provided (taped to the inside of the assembly) which may be used to hold the blade in some position other than minimum or maximum position. This fresh air assembly is located in the rear of the unit and to gain access to make these adjustments remove the air filter service door.

All capacity, efficiency and cost of operation information as required for Department of Energy "Energyguide" Fact Sheets are based upon the fresh air blank-off plate in place and is recommended for maximum energy efficiency.

The blank-off plate is available upon request from the factory and is installed in place of the fresh air damper shipped with each unit.

Vent Options

Barometric Fresh Air Damper (Standard)

Before starting, make sure the power has been turned off. The return air grille panel must be removed. The fresh air damper assembly can be seen on the back of the unit (see Figure 11).

1. The fresh air damper is attached to the back of the unit with one screw on either side of the assembly. Both of the screws must be removed.
2. Once the mounting screws are removed, tilt the assembly down and lift it out.

The mist eliminator can be seen through the opening. The mist eliminator must be raised up and the bottom can be pulled toward the front of the unit and removed.

FIGURE 11
Fresh Air Damper Assembly

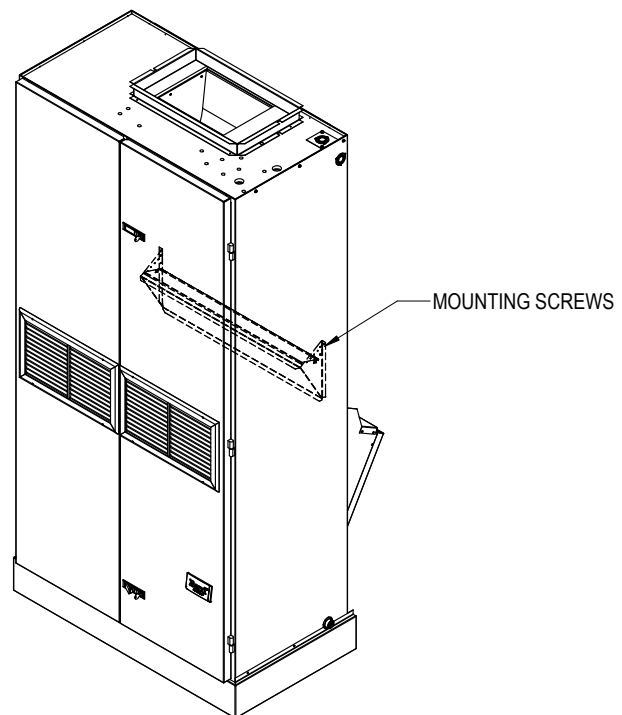

MIS-4182

Commercial Room Ventilator (Option)

Before starting, make sure the power has been turned off. The commercial room ventilator (CRV) can be seen after the main front doors are opened. The CRV must be removed to gain access to the mist eliminator.

1. The two mounting screws in the front of the CRV must be removed.
2. The power connectors for the CRV which are located on the left side (unplug from left side of voltage box in the control panel) must be disconnected. Squeeze the tabs on the sides of the connector and pull straight out.
3. Slide the CRV straight out of the unit.

The mist eliminator can be seen through the opening in the back of the unit. The mist eliminator must be raised up and the bottom can be pulled toward the front of the unit and removed.

Q-TEC Energy Recovery Ventilator (Option)

Before starting, make sure that the power has been turned off. The return air grille panel must be removed. The energy recovery ventilator (QERV) can be seen after the panel has been removed. To gain access to the mist eliminator, the QERV must be removed.

1. The front fill plate of the QERV must be removed. There is one screw on either side of the plate. Remove these screws and remove the plate.
2. On either side of the QERV there are mounting screws that hold the QERV in place. Remove both of these screws.
3. Underneath the heat recovery cassette is a power connector for the lower blower assembly. To disconnect this plug, squeeze the tabs on both sides of the plug to release the plug. While squeezing the tabs, pull the plug out of the socket.
4. The QERV power plug is on the right side (unplug from filter partition) and the control plug is on the left (unplug from left side of voltage box in the control panel). Both of these plugs must be disconnected to remove the QERV. Squeeze the tabs on the sides of the connector and pull straight out.
5. Slide the QERV assembly straight out of the unit, being careful not to let the cassette slide out of the QERV.

The mist eliminator can be seen through the opening in the back of the unit. The mist eliminator must be raised up and the bottom can be pulled toward the front of the unit and removed.

INSTALLATION

Basic Installation Design and Application Planning

Successful unit installations require proper planning and site inspection before installation begins. Before installing the unit, make sure that all service and airflow clearances are met and that the unit can meet all applicable code and regulation requirements. Provide an inspection of both the inside and outside of the structure by reviewing floorplans and/or visiting the installation site.

Mounting the Unit

The unit is shipped with the compressor secured to the compressor rails with two (2) shipping brackets. Although the unit will perform as designed with the shipping brackets in place, there may be an increase in noise and vibration levels. Remove and discard the shipping brackets once unit is positioned at its final installation location (see Figure 12).

The unit should now be unpackaged, removed from the skid and placed on a level floor near its install location. If the front doors are not aligned when closed, six (6) nylon washers have been provided, located on each door hinge, to be moved as needed to adjust the door alignment.

When installing a Q-TEC unit near an interior wall on the left side, a minimum of 8" is required but 12" is preferred.

When installing a Q-TEC unit near an interior wall on the right side, a minimum of 18" is required as additional space is needed to connect the side drain. If rear condensate drain kit QCDS48 is used, the minimum can be reduced to 8".

This clearance is required to allow for the attachment of the unit to the sleeve and side trim pieces to the wall.

This unit is to be secured to the wall sleeve with mounting brackets provided. The unit itself, the supply duct and the free blow plenum are suitable of "0" clearance to combustible material.

Following are the steps for mounting the Q-TEC. For reference see Figure 13A for external mounting bracket or 13B for internal bolt secured bracket (recommended).

1. Attach mounting brackets to the wall sleeve with screws provided. Either use external mounting bracket (Figure 13A) or internal bolt bracket (Figure 13B).
2. Position the unit in front of the sleeve with the condenser section toward the sleeve.
3. Remove the locking screws from the wheels (see Figure 14 on page 22).
4. Roll the unit into the sleeve. Make sure to check both sides of the unit as it is being rolled to keep it centered in the sleeve. Also check the alignment to the mounting brackets. This unit must be level from side to side. If adjustments are necessary, shim up under the rollers with sheets of steel or any substance that is not affected by moisture.
5. Make sure the gasket on the rear of the unit is touching the sleeve across the top and down both sides. This is a rain water seal.
6. Secure the mounting brackets to the unit with screws provided, #10 hex head sheet metal screws (Figure 13A) or use nut and washer to secure sleeve (Figure 13B).

FIGURE 12
Remove Compressor Shipping Brackets

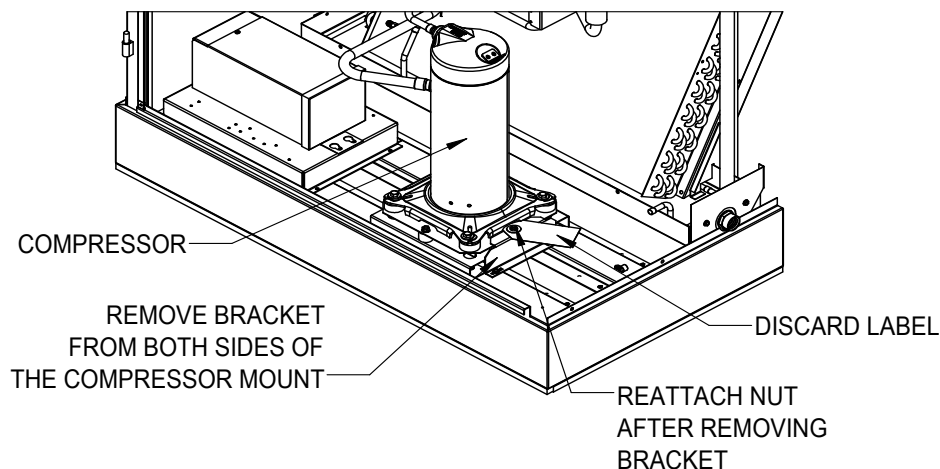

MIS-4240

FIGURE 13A
Unit Mounting – Method 1

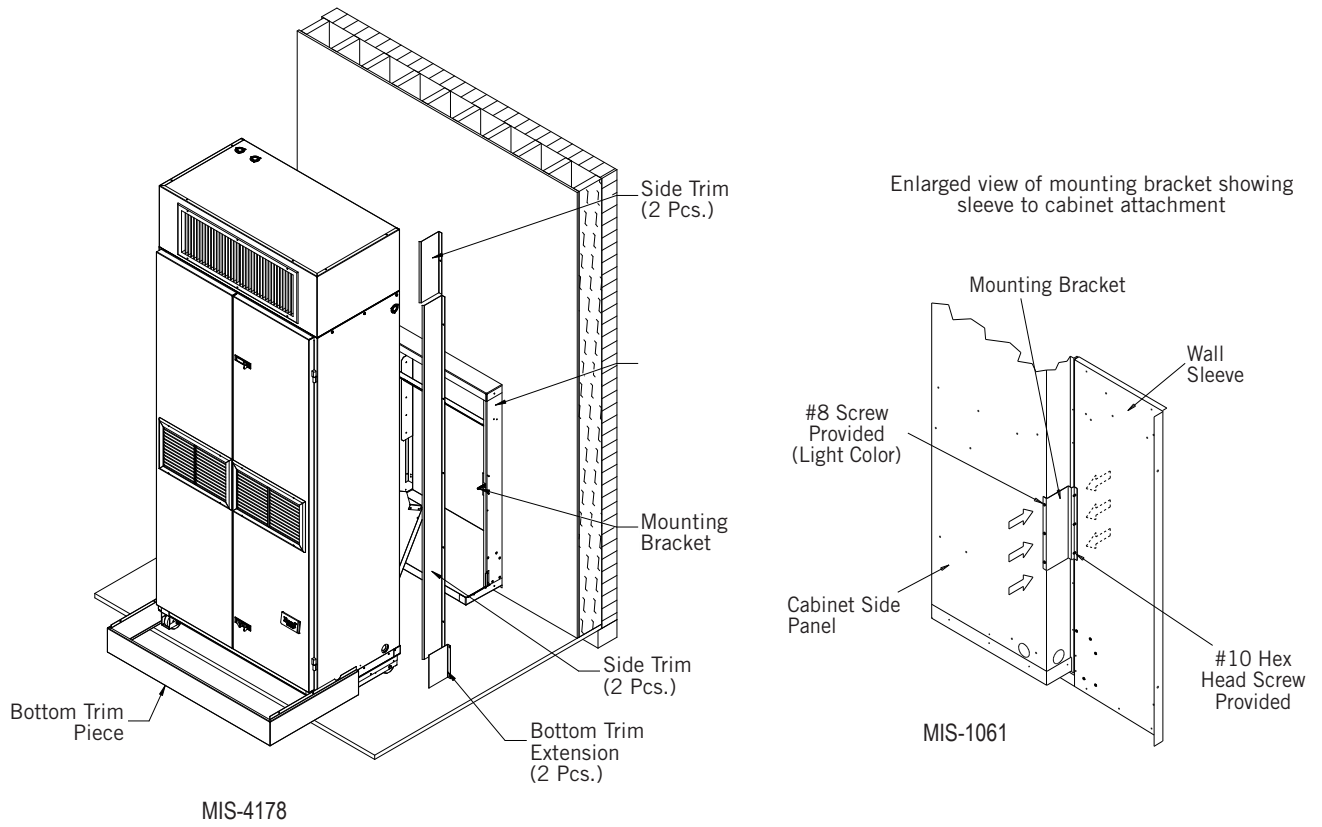

FIGURE 13B
Unit Mounting – Method 2

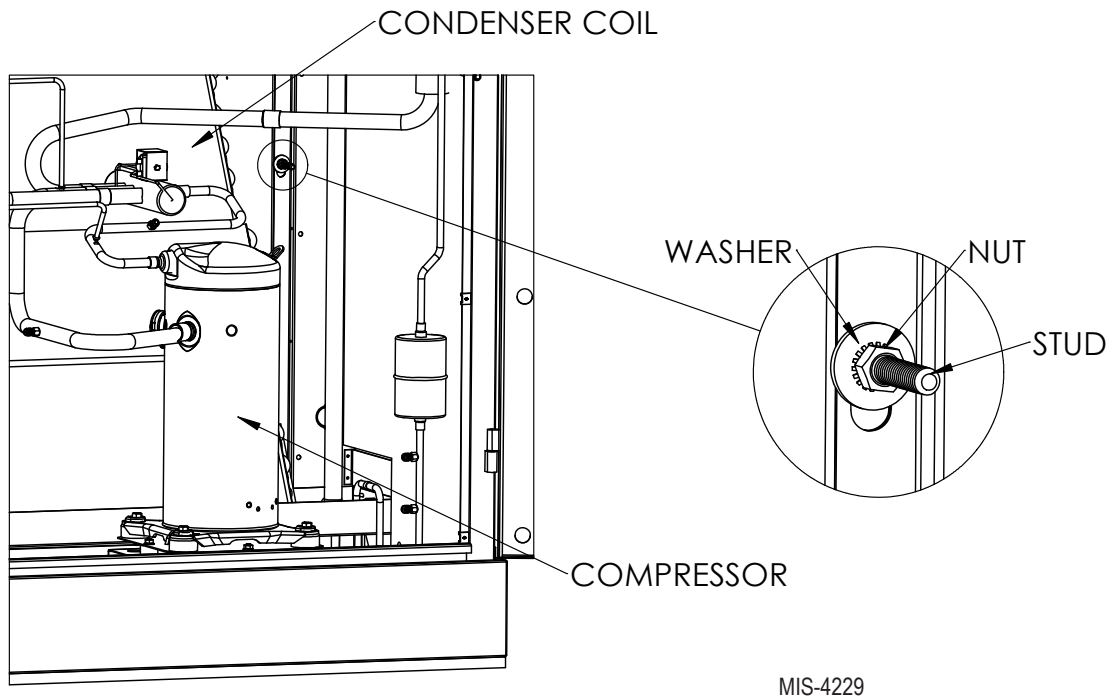
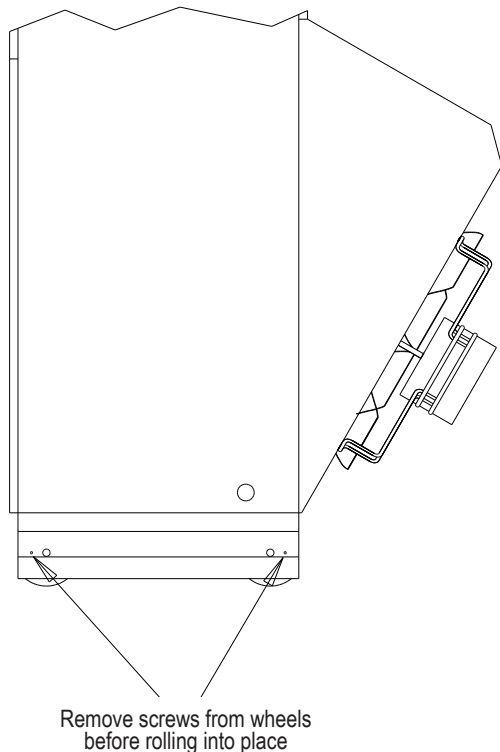

FIGURE 14
Remove Locking Screws from Wheels



MIS-1018

7. Bottom trim extensions are provided for use when wall is less than 14" but greater than 10.5". Secure to wall with screws (not provided).
8. Attach the bottom trim piece to the unit with the screws provided (dark colored).
9. Position side trim pieces to wall and attach with field-supplied screws. There are two long pieces and two short pieces supplied. The long pieces are to enclose the gap behind the unit. The short pieces are to fill the gap behind the cabinet extension or the free blow plenum box. They may be cut to suit ceiling height or overlap the unit side trim. There is sufficient length to trim up to a 10' 2" ceiling.

NOTE: If the exterior wall thickness is between 5" and 10.5", a side trim extension piece kit, model QSTX42, is available.

Condensate Drain

There are two drain connections on the unit. The rear drain is the primary drain, and is located on the right lower rear panel of the unit. The optional side drain is located on the bottom right side of the unit. The side drain is shipped with a plug installed.

The **side drain** requires a water trap for proper drainage (see Figure 15). The drain can be routed through the

floor or through the wall. **If the drain is to be routed through an unconditioned space, it must be protected from freezing.** The drain line must be able to be removed from the unit if it is necessary to remove the unit from the wall. When the side drain is used, the plug must be removed and installed in the rear drain outlet.

FIGURE 15
Optional Side Drain (Side View)

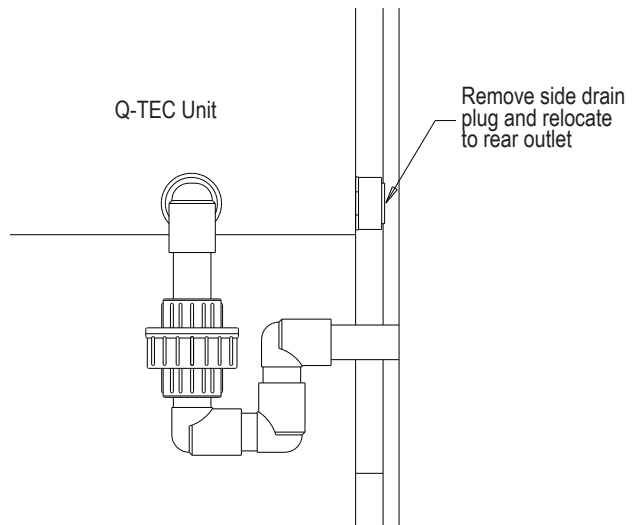

MIS-976

The **rear drain** can be used with wall thickness of up to 10" where a water trap can be installed between the unit and the interior wall (see Figure 16). The trap cannot extend beyond the edge of the unit or it will interfere with the wall mounting bracket. The drain can be routed through the floor or through the wall. If the drain is routed through the wall, the drain line must be positioned such that it will not interfere with the sleeve flange or the grille (see Figure 17). **If the drain is to be routed through an unconditioned space, it must be protected from freezing.**

FIGURE 16
Standard Rear Drain

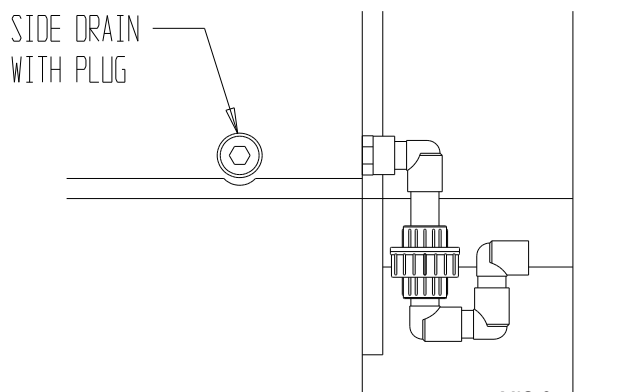

MIS-975

FIGURE 17
Rear Drain (Top View)

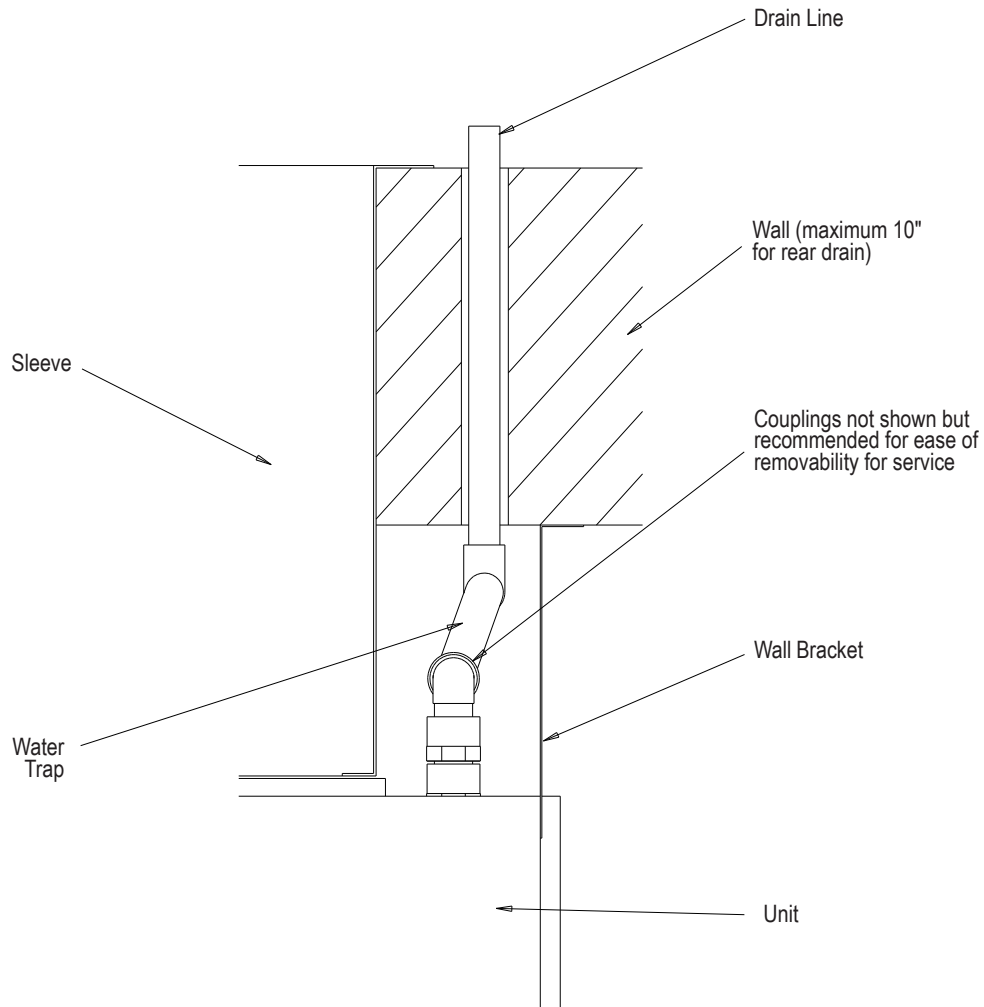

MIS-977

Optional Rear Drain Kits

Optional Rear Drain Kit Model QCDS48A is also available for these products. The optional rear drain kit offers multiple benefits that include the following:

- Allows unit to be rolled away from the sleeve without having to disconnect any hard plumbing connections.
- Allows indoor coil condensate to be easily connected to the rear drain box while bypassing the outdoor coil drain pan. This aids in minimizing the potential for biological growth to occur by minimizing the standing water and exposing it to warm temperatures.

See Figures 18A, 18B, 18C and 18D on pages 24-26.

The drain box permanently mounts onto the wall sleeve and is then either piped directly outdoors, or can be piped vertically. The Q-TEC unit is then equipped with fittings on the rear of the unit that slide into the drain box as it is wheeled towards the wall sleeve.

NOTE: Models equipped with a refrigerant subcooler in the lower drain pan may experience a 2-3% decrease in cooling performance and efficiency when the indoor condensate is routed around the outdoor coil drain pan/subcooler assembly. Unit rated performance and efficiency are with the indoor condensate routed to the outdoor coil pan.

There is also a heated version of the rear drain box available (Model #QCDS48H) for installation in northern climates where freezing may occur.

FIGURE 18A

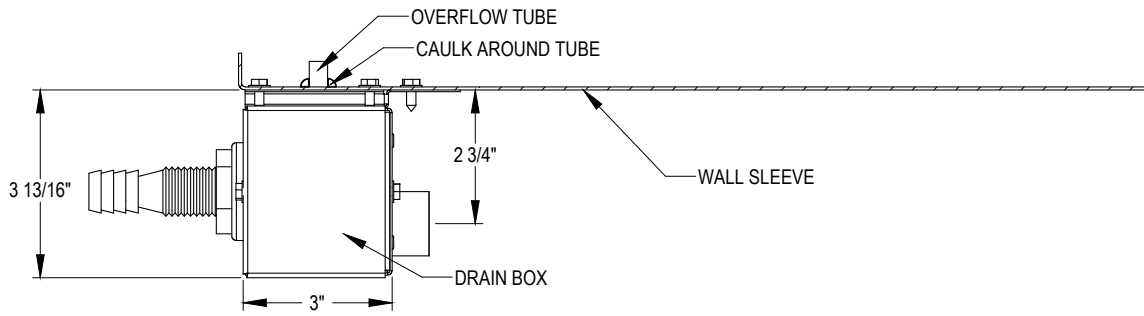

MIS-2469A

FIGURE 18B

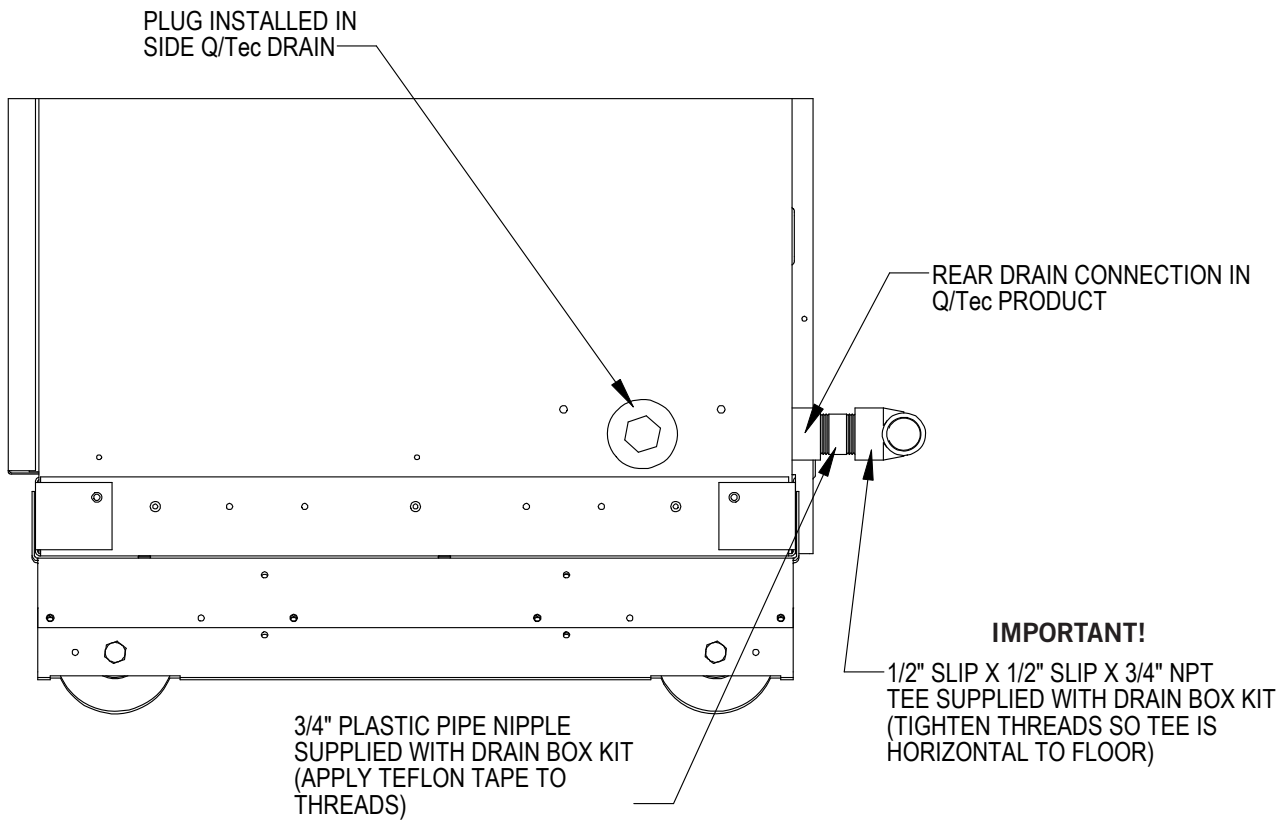

MIS-2470

FIGURE 18C

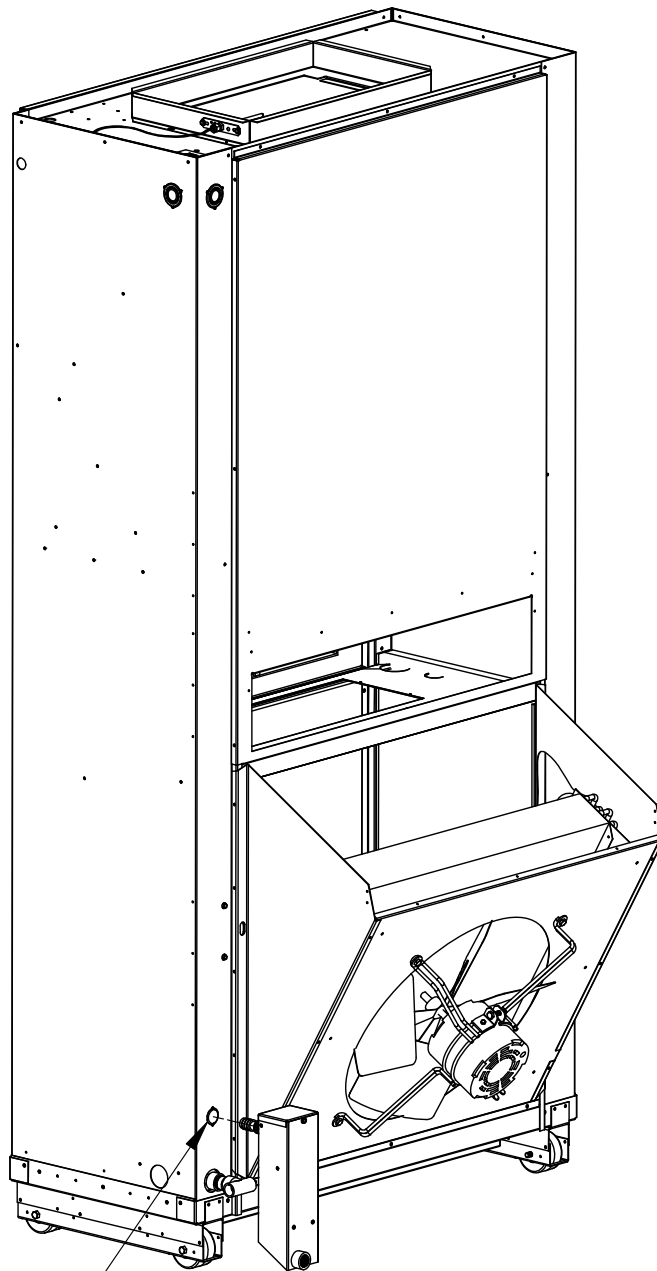

REMOVE KNOCK-OUT FOR
INDOOR DRAIN HOSE CONNECTOR
(If used)

MIS-2471 A

FIGURE 18D

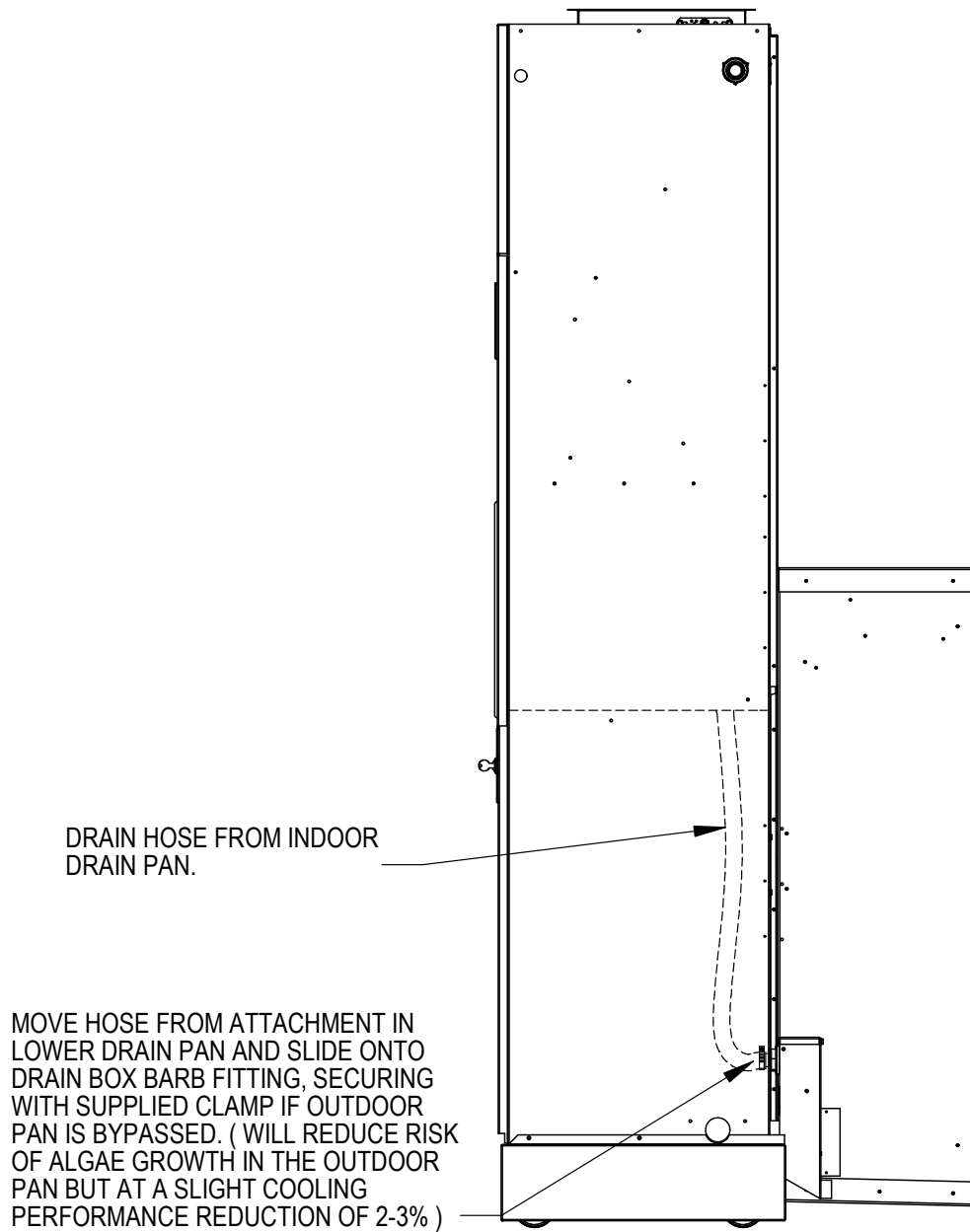

MIS-2472 A

Indoor Ducted and Non-Ducted Applications

Air distribution inside the structure being conditioned plays an important role in making sure the area is a consistent temperature. Improper air distribution can result in areas being cooler or warmer, electrical equipment not receiving sufficient airflow or occupancy discomfort felt inside an area. Thermostat or indoor temperature sensor placement inside the area being conditioned also plays an important role in indoor climate control.

Indoor Supply Airflow

Indoor installation areas must provide a non-restrictive path for the conditioned supply air to leave supply grilles and registers. Inspect the area to ensure that all indoor portions of the room or rooms will have access to supply air. Ductwork may be used to ensure proper air circulation and all provided ductwork guidelines and clearances must be followed. Non-ducted applications must use a supply box with supply grilles that installs on top of the unit. Be sure to adjust supply deflectors to properly disperse the conditioned supply air to all parts of the room. Avoid closing sections of the supply grilles which would cause unneeded supply duct pressurization.

Indoor Return Airflow

A non-restrictive path for room air returning to the center section of the unit must be provided inside the room. Avoid placing objects including furniture, electronics equipment, equipment racks and cabinets directly in front of the unit return grilles and registers. Bard recommends at least 2' between solid objects and return grilles or registers.

Ducted Applications

Field fabricated supply duct work may be installed inside the structure being conditioned. A short supply duct may be connected to the unit supply flanges before unit installation to help with duct connections inside the structure. Supply ducts must be properly sized for the design airflow requirement of the equipment. Air Conditioning Contractors of America (ACCA) is an excellent guide to proper sizing. All duct work or portions thereof not in the conditioned space should be properly insulated in order to conserve energy, reduce heat conductivity, and prevent condensation or moisture damage. Refer to Maximum External Static Pressure (ESP) of Operation table on page 52. Design the duct work according to methods given by the Air Conditioning Contractors of America (ACCA). When duct work is installed in unheated spaces, it should be insulated with a minimum of 1" of insulation. Use insulation with a vapor barrier on the outside of the insulation. Flexible joints should be used to connect the duct work to the equipment in order to keep the noise transmission to a minimum. Ducts

through the walls must be insulated and all joints taped or sealed to prevent air or moisture from entering the wall cavity.

All model series require a 1/4" clearance to combustible material for the first 3' of duct attached to the outlet air frame is required.

WARNING

Fire hazard.

Maintain minimum 1/4" clearance between the supply air duct and combustible materials in the first 3' of ducting.

Failure to do so could result in fire causing damage, injury or death.

Free Blow Applications

Some installations may not require extensive supply duct work throughout the structure and are referred to as free blow applications. Follow all clearances including distances to combustible materials and all instructions provided in this manual. A non-restrictive metallic supply air grille with deflectors is required for free blow applications. Contact the local Bard distributor or visit www.bardhvac.com for ordering information.

A top supply box is required for non-ducted applications. The spacing between louvers on the grille shall not be larger than 5/8".

Thermostat or Indoor Temperature Sensor Placement

The location and installation of the thermostat or temperature sensor that monitors indoor temperature is very important regarding unit operation. Avoid placing the thermostat in an area exposed to direct sunlight or air from doorways leading outdoors. Use a piece of insulating material to close off conduit openings or holes in the wall surface for wire entry into the thermostat or temperature sensor. This will help avoid non-conditioned air from entering the thermostat and effecting temperature and/or humidity readings. As common practice, the thermostat or temperature sensor should measure the temperature of the air being returned to the unit, and not the conditioned air being supplied by the unit. Placing the thermostat or temperature sensor near a return air opening will normally result in optimal unit performance.

FIGURE 19
Unit Dimensions

	A	B (Width)	C (Plenum Supply)	D (Returns)	E (Trim Width)
Q36AF Q42AF	5.0	42.0	30.0	(2) 17.0	43.0
Q48AF	3.0	48.0	40.0	(2) 20.0	49.0

All dimensions are in inches. Dimensional drawings are not to scale.

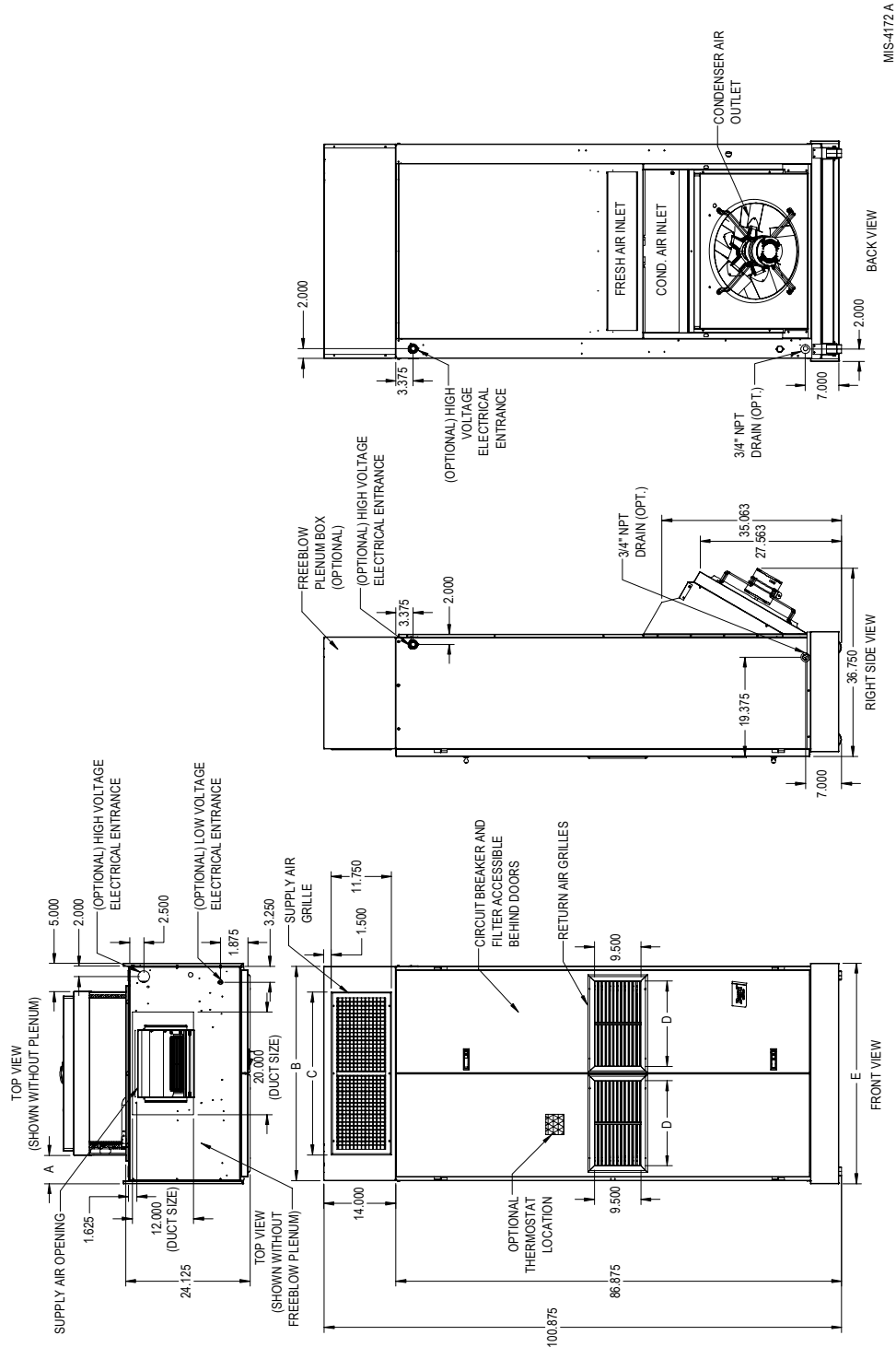

Wiring – Main Power

Main electrical power must be supplied to the unit from a clean, reliable power source. Verify voltage being supplied to the unit is consistent during all times of the day and within the range specified for the unit in the unit specifications and on the unit serial plate. Voltage must be measured at the field power connection point in the unit and while the unit is operating at full load (maximum amperage operating condition).

Refer to the unit serial plate and unit specifications for maximum fuse or circuit breaker size. Each outdoor unit is marked with a “Minimum Circuit Ampacity”. This means that the field wiring used must be sized to carry that amount of current. Depending on the installed kW of electric heat, there may be two field power circuits required. If this is the case, the unit serial plate will so indicate.

All models are suitable only for connection with copper wire. Each unit and/or wiring diagram will be marked “Use Copper Conductors Only”. These instructions must be adhered to. Refer to the National Electrical Code (NEC) for complete current carrying capacity data on the various insulation grades of wiring material. All wiring must conform to NEC and all local codes.

The electrical data on the serial plate, in the unit specifications and also in Table 9 on page 51 list fuse sizes for all models including the most commonly used heater sizes. Also shown are the number of field power circuits required for the various models with heaters. The unit rating plate lists a “Maximum Time Delay Relay Fuse” or circuit breaker that is to be used with the equipment. The correct type and size must be used for proper circuit protection and also to ensure that there will be no nuisance tripping due to the momentary high starting current of the compressor motor.

Three phase models must have proper phasing. A phase monitor is included in all three phase models, and will indicate improper phasing during a call for cooling (24VAC at Y1 terminal). See provided information included in this document regarding the phase monitor.

High Voltage Connections

Field wires can enter the cabinet through either a top or side knock-out on the right. Both entrance points will utilize the wire channel to direct field wires to the control panel. Figure 20 shows the entrance points and wire routing.

FIGURE 20
High Voltage Connections

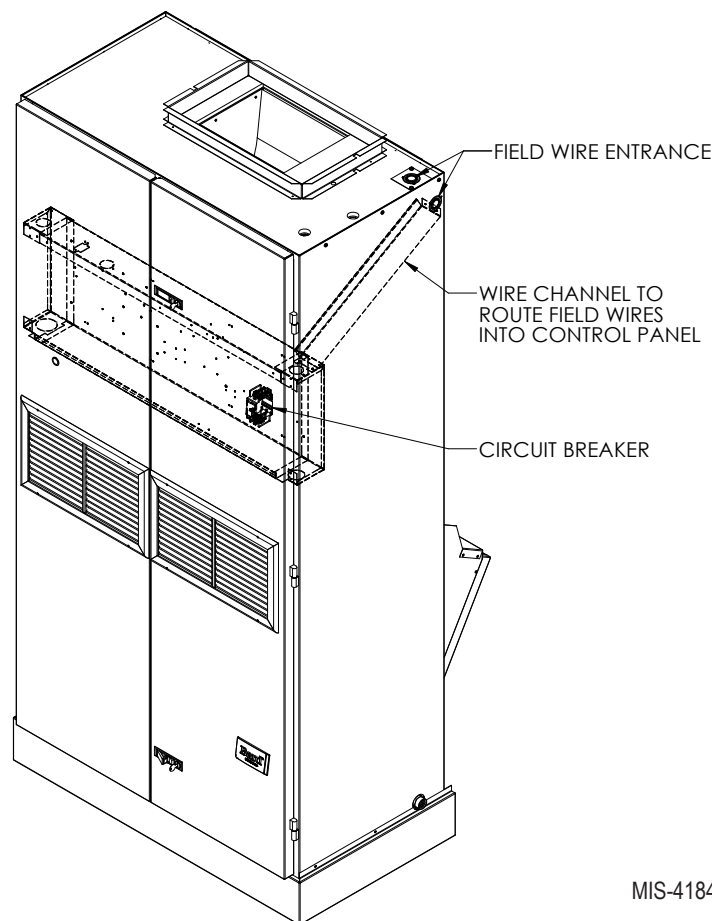

MIS-4184

Wiring – Low Voltage

All 230/208V 1 phase and 3 phase equipment have dual primary voltage transformers. All equipment leaves the factory wired on 240V tap. For 208V operation, reconnect from 240V to 208V tap. The acceptable operating voltage range for the 240 and 208V taps are:

Tap: 240 Range: 253 – 216
Tap: 208 Range: 215 – 197

NOTE: *The voltage should be measured at the field power connection point in the unit and while the unit is operating at full load (maximum amperage operating condition).*

For low voltage wiring, an 18 gauge copper, color-coded cable is recommended. See Table 3 for more information.

Low Voltage Connections

These units use a 24-volt AC low voltage circuit.

C terminal is the *24VAC common and is grounded.*

G terminal is the *indoor blower input.*

Y1 terminal is the *1st Stage input for cooling.*

Y2 terminal is the *2nd Stage input for cooling* (if equipped with an economizer) or *Y2 disables Balanced Climate mode if the Y1-Y2 jumper is removed* (see page 30).

B/W1 terminal is the *first stage electric heat* (if equipped).

W2 terminal is the *2nd stage of electric heat or emergency heat* (if equipped).

A terminal is the *ventilation input*. This terminal energizes any factory-installed ventilation option and indoor blower.

D terminal is the *dehumidification input*. This terminal energizes dehumidification.

L terminal is *24 volt alarm active output*.

Unit Shutdown Feature (Standard on All Models)

The RT terminal is the 24VAC transformer output, and the R terminal is the 24VAC hot terminal for the operation of the equipment. RT and R are connected with a brass jumper bar which can be removed and RT and R connected to an external NC (normally closed) contact such as a fire/smoke detector that will cause shutdown of the equipment upon activation.

Balanced Climate™ Feature (Standard on All Models)

All units are equipped with the capability of running in Balanced Climate mode. This mode is designed to enhance the comfort level by reducing the indoor airflow amount and extending the run time to help extract more humidity during cooling operation. In heating mode, the reduced airflow provides a warmer supply air temperature creating more comfortable heat. The Y1 terminal is the 24VAC input for Balanced Climate

compressor cooling operation. The Y2 terminal is the 24VAC input for compressor cooling standard operation. Y1 and Y2 are connected with a brass jumper bar which can be removed to enable Balanced Climate mode. The Q-TEC products come standard with two low voltage strips (one in the blower section and another in the control panel). Each low voltage strip will need the Y1-Y2 jumper removed for proper Balanced Climate operation. Units with an economizer will not have the brass jumper installed. Refer to vent manuals for instructions on how Balanced Climate works with each vent.

NOTE: *Units with mechanical dehumidification require an additional connection to be made when enabling Balanced Climate. Refer to the dehumidification supplemental instructions for this step.*

To operate in Balanced Climate mode, a 2-stage thermostat is required. The lower indoor airflow operation is overridden by utilizing a 2-stage thermostat. If the call for cooling is not satisfied within a given time frame or temperature differential (specified by the thermostat), the thermostat will send a signal to Y2 which then increases the blower speed back to the selected speed.

Refer to page 38 for additional Balanced Climate requirements and limitations.

Dehumidification Feature

The D terminal is the 24VAC input for dehumidification operation. When 24VAC is applied to the D terminal, a 3-way valve solenoid is energized. The reheat coil located behind the evaporator coil is then active to reheat the supply air during cooling mode. This allows humidity to be removed from the air entering the unit without a large amount of sensible cooling capacity. During dehumidification, the indoor blower speed is reduced to help with the humidity removal. A humidity sensing thermostat or humidistat is required to control dehumidification operation.

If there is a call for dehumidification and comfort cooling at the same time, the call for cooling takes precedence over dehumidification.

If there is a call for dehumidification and first stage heating, the call for dehumidification takes precedence over first stage heating. A second stage heating call will cancel dehumidification.

Ventilation Features (Optional)

See ventilation instructions provided with unit for low voltage wiring.

Low Ambient Control (Optional)

The low ambient control (LAC) is a pressure switch that is attached to the liquid line of the system and monitors

high side system pressure. Operation of the LAC occurs as outdoor temperatures drop below 60°F. LAC operation cycles the condenser fan on/off based on outdoor temperature.

Freeze Protection Thermostat

An evaporator freeze protection thermostat is supplied with all units. The freeze thermostat cuts out compressor operation if the evaporator begins to freeze up.

**TABLE 1
Low Voltage Connections for DDC Control**

	Standard Units	Units w/ Economizers
Fan Only	Energize G	Energize G
1st Stage Cooling Mode/ Balanced Climate	Energize Y1, G	Energize Y1, G
2nd Stage Cooling Mode	Energize Y2 to override Balanced Climate mode when Y1-Y2 jumper is removed	Energize Y1, Y2, G
1st Stage Heating	Energize B/W1	Energize B/W1
2nd Stage Heating (if employed)	Energize B/W1, W2	Energize B/W1, W2
Ventilation	Energize A	Energize A
Dehumidification (if employed)	Energize D	Energize D

**TABLE 2
CO₂ Controllers**

Part Number	Predominate Features
8403-096	Normally Open SPST relay closes-on-rise 24V dual wave length sensor. Default setting 950ppm, adjustable to 0-2000ppm Default off setting 1000ppm, adjustable to 0-200 ppm can be calibrated

**TABLE 3
Thermostat Wire Size**

Transformer VA	FLA	Wire Gauge	Maximum Distance In Feet
55	2.3	18 gauge	60
		16 gauge	100
		14 gauge	160
		12 gauge	250

**TABLE 4
Wall Thermostats**

Thermostat	Predominant Features
8403-060 (1120-445)	3 Stage Cool, 3 Stage Heat Programmable/Non-Programmable Electronic HP or Conventional Auto or Manual Changeover Dehumidification Output
8403-081 (BrightStat)	2 Stage Cool, 2 Stage Heat Programmable/Non-Programmable Electronic HP or Conventional Auto or Manual Changeover with Humidity and Occupancy Sensor BACnet (Thermostat option only permissible for units up to 12 kW electric heat)
8403-083 (BrightStat)	2 Stage Cool, 2 Stage Heat Programmable/Non-Programmable Electronic HP or Conventional Auto or Manual Changeover with Humidity (only) BACnet (Thermostat option only permissible for units up to 12 kW electric heat)
8403-089 (T4 Pro)	1 stage Cool, 1 stage Heat – Heat Pump; 1 stage Cool, 1 stage Heat – Conventional; Programmable/Non-Programmable Electronic; Auto or Manual changeover
8403-090 (T6 Pro)	2 Stage Cool, 3 Stage Heat – Heat Pump 2 Stage Cool, 2 Stage Heat – Conventional Programmable/Non-Programmable Electronic Auto or Manual Changeover
8403-091	1 stage Cool, 1 stage Heat; Non-Programmable; FEMA use
8403-092 (T6 Pro Wi-Fi)	2 Stage Cool, 3 Stage Heat – Heat Pump 2 Stage Cool, 2 Stage Heat – Conventional Programmable/Non-Programmable Electronic Auto or Manual Changeover Wi-Fi
8403-095 (T4 Pro)	1 stage Cool, 2 stage Heat – Heat Pump; 1 stage Cool, 1 stage Heat – Conventional; Programmable/Non-Programmable Electronic; Auto or Manual changeover

**TABLE 5
Humidity Controls**

Part Number	Predominate Features
8403-100* (H6062A1000)	Electronic humidistat DPST Humidity range 10-90% with adjustable stops
8403-047 (H200-10-21-10)	Electronic dehumidistat SPST closes-on-rise Humidity range 10-90% with adjustable stops

* If using Honeywell HumidiPRO (H6062A1000) 8403-100 humidistat, it must be configured for dehumidification in the menu.

FIGURE 21
Thermostat Connections

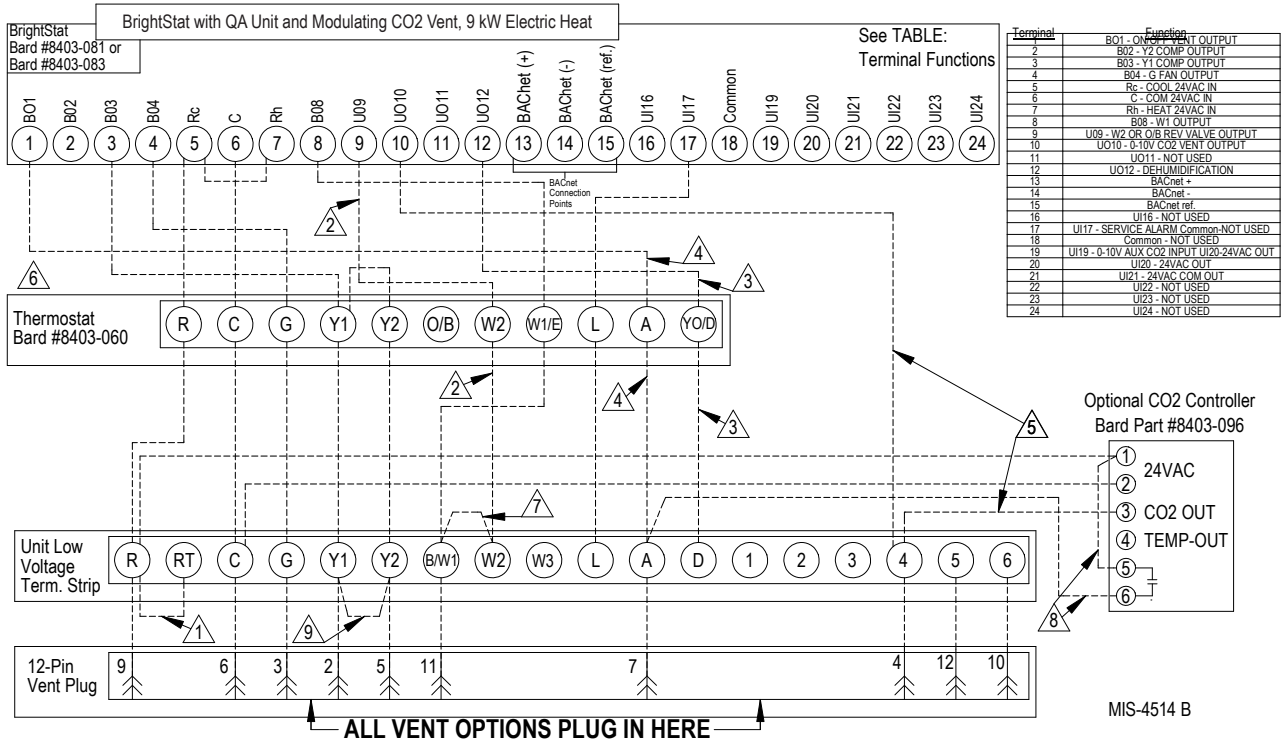

- 1 Factory installed jumper. Remove jumper and connect to N.C fire alarm circuit if emergency shutdown required.
- 2 Wire not needed below 15KW.
- 3 Wire required for dehumidification models only.
- 4 Do not connect "A" from thermostat if optional CO2 controller is used
- 5 0-10 VDC modulating CO2 control signal for modulating ventilation control (optional for ECON only - see vent instruction manuals)
- 6 Change model configuration from heat pump to heat/cool. Must be configured to programmable and fan set to be programmed fan for the "A" output to function during scheduled occupied periods. Must be configured for multi-stage for Y1 output to be active 1st stage cooling. For dehumidification, must be configured for "No Economizer" for YO/D to be active for humidity control.
- 7 Install jumper for 1 stage electric heat on units with more than 10KW
- 8 Do not add these wires if setting up for modulating control. See note 5.
- 9 Factory installed jumper. Remove jumper to activate Balanced Climate™ mode. A 2-stage thermostat is recommended for Balanced Climate mode.

FIGURE 22
Thermostat Connections

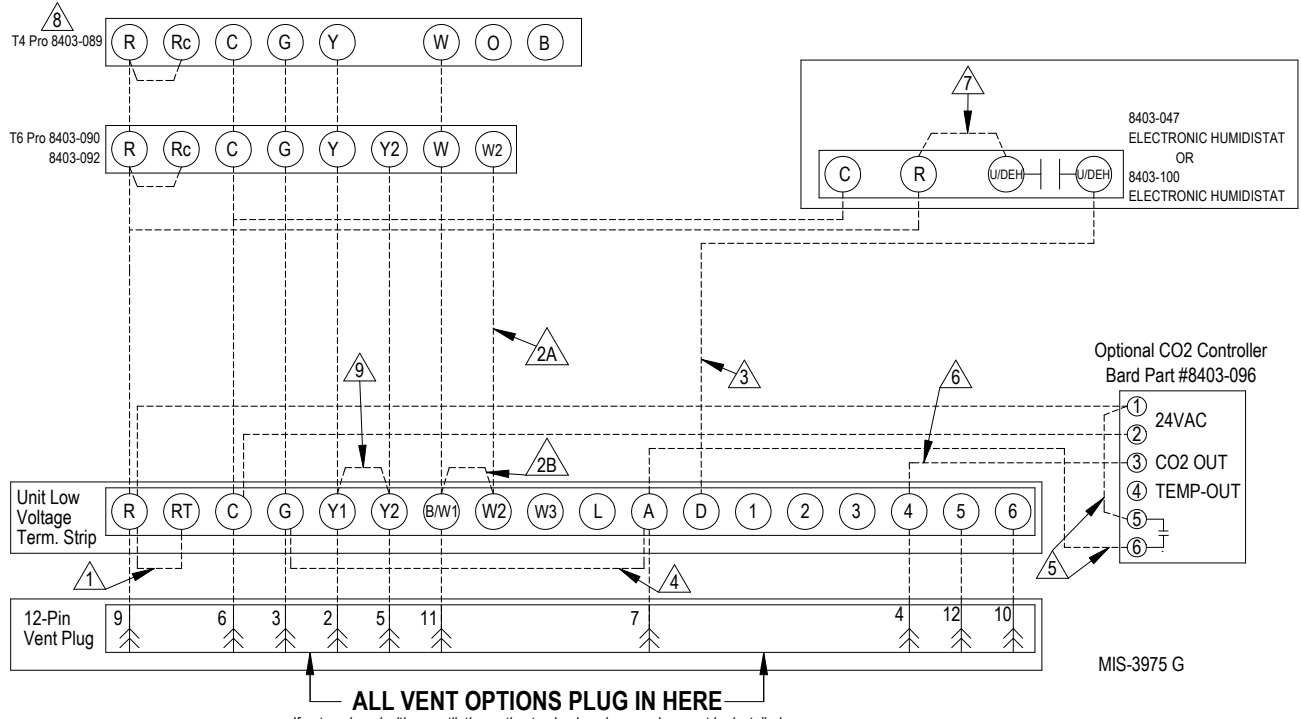

- ⚠️ FACTORY INSTALLED JUMPER. REMOVE JUMPER AND CONNECT TO N.C FIRE ALARM CIRCUIT IF EMERGENCY SHUTDOWN REQUIRED.
- ⚠️ WIRE NOT NEEDED BELOW 15KW.
- ⚠️ INSTALL JUMPER FOR 1 STAGE ELECTRIC HEAT ON UNITS WITH MORE THAN 10KW.
- ⚠️ WIRE REQUIRED FOR DEHUMIDIFICATION MODELS ONLY.
- ⚠️ FOR VENT OPERATION, ADD JUMPER IF OPTIONAL CO2 CONTROLLER IS NOT USED. VENT WILL RUN WHILE BLOWER IS ENERGIZED. FOR ECON & CRV-V AN ADDITIONAL WIRE CHANGE IS REQUIRED SEE INSTALL MANUAL.
- ⚠️ DO NOT ADD THESE WIRES IF SETTING UP FOR MODULATING CONTROL. SEE NOTE 6.
- ⚠️ 0-10 VDC MODULATING CO2 CONTROL SIGNAL FOR MODULATING VENTILATION CONTROL (OPTIONAL FOR ECON ONLY) - SEE VENT INSTALLATION MANUAL.
- ⚠️ JUMPER NEEDS ADDED.
- ⚠️ THERMOSTAT WILL NOT WORK WITH UNITS EQUIPPED WITH ECONOMIZERS UNLESS CO2 CONTROLLER IS USED.
- ⚠️ FACTORY INSTALLED JUMPER. REMOVE JUMPER TO ACTIVATE BALANCED CLIMATE™ MODE. A 2-STAGE THERMOSTAT IS RECOMMENDED FOR BALANCED CLIMATE MODE. Y1 Y2 JUMPER NOT PRESENT IF ECONOMIZER IS FACTORY INSTALLED. UNITS WITH ECONOMIZERS HAVE BALANCED CLIMATE. JUMPER IN ECONOMIZER, REFER TO ECONOMIZER MANUAL.
- ⚠️ HUMIDISTAT 8403-100 WILL NEED TO BE CONFIGURED FOR DEHUMIDIFICATION IN THE MENU. SEE USER'S MANUAL.

START UP

NOTICE

These units require R-454B refrigerant and polyol ester oil.

General

1. R-454B refrigerant is classified as an A2L, or mildly flammable refrigerant. Refer to A2L Refrigerant Safety Manual 2100-810 for information regarding safe practices for charging, recovering, decommissioning and general handling of A2L refrigerants.
2. Use separate service equipment to avoid cross contamination of oil and refrigerants.
3. Use recovery equipment rated for R-454B refrigerant.
4. Use manifold gauges rated for R-454B (800 psi/250 psi low).
5. R-454B is a zeotropic blend of HFC-32 and HFO-1234yf. Charge with liquid refrigerant.
6. R-454B has an ozone depletion potential of zero, but must be recovered due to its global warming potential.
7. R-454B compressors use polyol ester oil.
8. Polyol ester oil is hygroscopic; it will rapidly absorb moisture and strongly hold this moisture in the oil.
9. A liquid line dryer must be used—even a deep vacuum will not separate moisture from the oil.
10. Limit atmospheric exposure to 15 minutes.
11. If compressor removal is necessary, always plug compressor immediately after removal. Purge with small amount of nitrogen when inserting plugs.

Topping Off System Charge

If a leak has occurred in the system, Bard Manufacturing recommends recovering, evacuating (see manual 2100-810) and charging to the nameplate charge.

Since R-454B is a zeotropic blend, one component may leak off before another component in the event of a leak. This can cause significant changes to the concentration of each component in the system. For this reason, Bard Manufacturing does not recommend topping off the system charge.

REMEMBER: When adding R-454B refrigerant, it must come out of the charging cylinder/tank as a liquid to avoid any fractionation, and to ensure optimal system performance. Refer to instructions for the cylinder that is being utilized for proper method of liquid extraction.

WARNING

Failure to conform to these practices could lead to damage, injury or death.

Safety Practices

1. Never mix R-454B with other refrigerants.
2. Use gloves and safety glasses. Polyol ester oils can be irritating to the skin, and liquid refrigerant will freeze the skin.
3. Never use air and R-454B to leak check; the mixture is flammable.
4. Do not inhale R-454B—the vapor attacks the nervous system, creating dizziness, loss of coordination and slurred speech. Cardiac irregularities, unconsciousness and ultimate death can result from breathing this concentration.
5. Do not burn R-454B. This decomposition produces hazardous vapors. Evacuate the area if exposed.
6. Use only cylinders rated DOT4BA/4BW 400.
7. Never fill cylinders over 80% of total capacity.
8. Store cylinders in a cool area, out of direct sunlight.
9. Never heat cylinders above 125°F.
10. Never trap liquid R-454B in manifold sets, gauge lines or cylinders. R-454B expands significantly at warmer temperatures. Once a cylinder or line is full of liquid, any further rise in temperature will cause it to burst.

Vent Connection Plug

All units are equipped with a vent connection plug in the side of the low voltage box inside the control panel on the left side for the different ventilation packages to plug in to. If the compressor will not start and there is no "Y1" at the compressor control logic board, first check to make sure that either the optional vent is plugged into the vent connection plug or the supplied jumper plug is in place.

The unit will not operate without anything plugged in.

This plug is located in the side of the low voltage box inside the control panel on the left side behind the inner

control panel cover. If the unit is supplied with a factory-installed vent package, it will be plugged in but the jumper plug will also be tethered next to the connection for troubleshooting purposes, if necessary.

Pressure Service Ports

High and low pressure service ports are installed on all units so that the system operating pressures can be observed. Pressure tables covering all models can be found on page 46. It is imperative to match the correct pressure table to the unit by model number.

This unit employs high-flow Coremax valves instead of the typical Schrader-type valves.

WARNING! Do NOT use a Schrader valve core removal tool with these valves. Use of such a tool could result in eye injuries or refrigerant burns!

To change a Coremax valve without first removing the refrigerant, a special tool is required which can be obtained at www.fastestinc.com/en/SCCA07H. See the replacement parts manual for replacement core part numbers.

Important Installer Notes

For improved start up performance, wash the indoor coil with a dishwashing detergent.

Dehumidification Models

Exposure to high pressure refrigerant hazard.

Dehumidification models are equipped with an electronic expansion valve (EEV). In order to fully recover refrigerant or evacuate system during repairs, either use service tool P/N 2151-021 to manually open the EEV or be sure to recover and evacuate from all service ports: suction, liquid and discharge.

Failure to do so could result in eye injuries and/or refrigerant burns.

Service Hints

1. Caution owner/operator to maintain clean air filters at all times and also not to needlessly close off supply and return air registers. This reduces airflow through the system, which shortens equipment service life as well as increasing operating costs.
2. Check all power fuses or circuit breakers to be sure they are the correct rating.
3. Periodic cleaning of the outdoor coil to permit full and unrestricted airflow circulation is essential.

High and Low Pressure Switches

All Q**AF series models are supplied with high and low pressure switches that reset automatically in response to system pressures. High pressure switch settings: Opens 615 +/- 15 PSI, closes 490 +/- 15 PSI. Low pressure switch settings: Opens 14 +/- 4 PSI, closes 30 +/- 5 PSI.

Pressure Switch Lockout

The high and low pressure switches are included in a lockout circuit that is re-settable from the room. In the event of a high or low pressure switch lockout, a visual indication can be seen from the compressor logic control board. See **Troubleshooting Compressor Logic Control Board** on page 36 for further explanation.

Three Phase Scroll Compressor Start Up Information

Scroll compressors, like several other types of compressors, will only compress in one rotational direction. Upon start up, direction of rotation is not an issue with single phase compressors since they will always start and run in the proper direction.

However, three phase compressors will rotate in either direction depending upon phasing of the power. Since there is a 50-50 chance of connecting power in such a way as to cause rotation in the reverse direction, verification of proper rotation must be made. A phase rotation meter can be used to verify a clockwise phase is being supplied. Verification of proper rotation direction can also be made by observing that suction pressure drops and discharge pressure rises when the compressor is energized. Reverse rotation also results in an elevated sound level over that with correct rotation, as well as substantially reduced current draw compared to tabulated values.

Verification of **proper rotation** must be made at the time the equipment is put into service. If improper rotation is corrected at this time, there will be no negative impact on the durability of the compressor. However, reverse operation for over 1 hour may have a negative impact on the bearing due to oil pump out.

NOTE: *If compressor is allowed to run in reverse rotation for an extended period of time, the compressor's internal protector will trip.*

All three phase compressors are wired identically internally. As a result, once the correct phasing is determined for a specific system or installation, connecting properly phased power leads to the same Fusite terminal should maintain proper rotation direction.

The direction of rotation of the compressor may be changed by reversing any two line connections to the unit.

Compressor Control Logic Board

When the green status light blinks, this indicates that 24 volt power is applied to the board and the controller is running in normal operation (see Figure 23 on page 36).

On initial power up and call for compressor, a 5-minute delay plus a random start delay of 0 to 60 seconds is applied. After the random delay, the compressor relay is energized (terminal CC). When the Y1 input opens, the compressor de-energizes.

The compressor logic control board is standard on all models covered by this manual. It is an anti-short cycle/lockout timer with high pressure, low pressure and freeze stat switch monitoring and alarm output.

After compressor shutdown, or power disruption, a 5-minute timer is applied which prevents the compressor from operating.

Over and Under Voltage Protection

When an under or over voltage condition exists, the controller locks out the unit. When condition clears, the controller automatically releases the unit to normal operation and the compressor restarts after the random start and anti-short cycle timings are met. The under and over voltage protection starts at plus or minus 20% from nominal voltage and returns to operation at plus or minus 10% from nominal voltage. All four LED fault lights will flash when an over or under voltage conditions occurs. The over voltage protection can be disabled by removing the O/V jumper on the logic control board (see Figure 23).

FIGURE 23
Compressor Logic Control Board

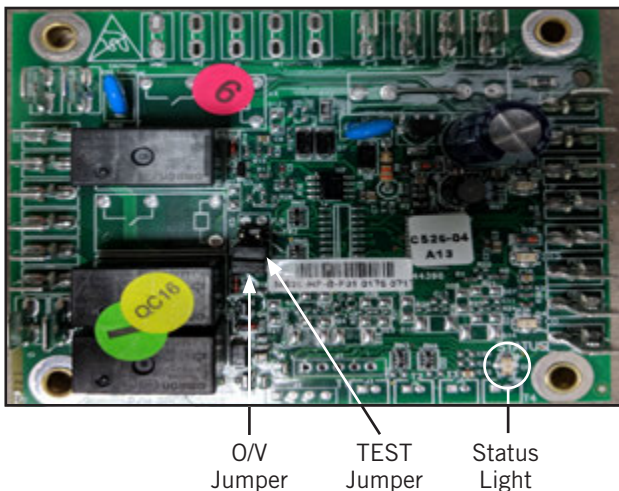

Intelligent Reset

The compressor logic control board has an intelligent reset feature after a safety control is activated. The controller locks out the unit for 5 minutes; at the end of this period, the controller checks to verify that all faults have been cleared. If faults have been cleared, the controller restarts the unit. If a second fault occurs, the controller will lockout the unit until the control is reset by breaking Y signal from thermostat. The last fault will be kept in memory after a full lockout; this is only cleared by cycling the unit power.

Alarm Output

The L terminal has 24 volts applied when a hard lockout occurs. This can be used to drive a fault light or a low voltage relay.

During routine operation of the unit with no power interruptions, the compressor will operate on demand with no delay.

High Pressure Switch and Lockout Sequence

If the high pressure switch opens, the compressor contactor will de-energize immediately. The lockout timer will go into a *soft lockout* and stay in soft lockout until the high pressure switch closes **and** the delay on break time has expired. If the high pressure switch opens again in the same operating cycle, the unit will go into *manual lockout* condition and the alarm relay circuit will energize. Recycling the wall thermostat resets the manual lockout.

NOTE: *Both high and low pressure switch controls are inherently automatic reset devices. The high pressure switch and low pressure switch cut out and cut in settings are fixed by specific unit model. The lockout feature, both soft and manual, are a function of the compressor logic control board.*

Troubleshooting Compressor Control Logic Board

The Bard Q**AFD Series is equipped with a high pressure switch, low pressure switch and freeze stat switch. The switches are all located in the condenser section of the unit. Each switch has its own illuminated diagnostic light, which provides the user an easy solution for basic troubleshooting.

High Pressure Switch

(Terminals HP1 and HP2) Circuit will be proved as “closed” prior to energizing A or CC terminals. If pressure switch opens, compressor will go into soft lockout mode and compressor operation will be terminated; green fault light will be illuminated. Logic control will then go through 5-minute delay on break plus random start sequence. If no fault is found on next run cycle, compressor will continue operation. If fault reoccurs, a hard lockout will be initiated and fault signal is sent to L terminal.

Low Pressure Switch

(Terminals LP1 and LP2) Circuit will be proved as “closed” prior to energizing A or CC terminals. The condition of the LP terminals will then be ignored for the first 90 seconds after a demand for compressor operation. Following this 90-second period, if pressure switch opens, compressor will go into soft lockout mode and compressor operation will be terminated; orange fault light will be illuminated. The compressor control board will then go through a 5-minute delay on break plus random start sequence. If no fault is found on next run cycle, compressor will continue operation. If fault reoccurs, hard lockout will be initiated and the fault signal is sent to the L terminal.

Freeze Stat Switch

(Terminals FS1 and FS2) Circuit will be proved as “closed” prior to energizing CC terminal. If freeze stat switch opens, compressor will go into soft lockout mode and compressor operation will be terminated; red fault light will be illuminated. Compressor logic control will then go through 5-minute delay on break plus random start sequence. If no fault is found on next run cycle, compressor will continue operation. If fault reoccurs, hard lockout will be initiated and fault signal is sent to L terminal.

The freeze stat switch is located on the return bend tube located on the evaporator coil. When there is a fault related to the freeze stat switch, a red LED light will give notice by illumination, indicating a fault condition is present.

Logic Control Board

Three of the four switches have normally closed contacts and one contact (CO = unused) has a normally open contact. If any of the four switches fault, their corresponding light will blink and initialize a soft lockout of the compressor circuit. If recurrence happens on the same cooling call cycle, a hard lockout of the compressor circuit will occur requiring a manual system reset.

The compressor logic control board has five LED lights providing status updates of the system operation (see Figure 24). When the green status light is blinking, this is an indication that there is 24V power to the board. Upon an alarm detection from one of the four safety switches, there will be a blinking light indicating a fault. The faults are as follows:

HP = Green fault illumination (High Pressure)

LP = Orange fault illumination (Low Pressure)

FS = Red fault illumination (Freeze Stat)

CO = Yellow fault illumination (Not Used)

Phase Monitor

All units with three phase scroll compressors are equipped with a three phase line monitor to prevent compressor damage due to phase reversal.

The phase monitor in this unit is equipped with two LEDs. If the Y signal (call for cooling) is present at the phase monitor and phases are correct, the green LED will light.

NOTE: *The phase monitor will not show phase reversal until the compressor is energized during a call for cooling operation.*

If phases are reversed, the red fault LED will be lit and compressor operation is inhibited. The phase monitor will also inhibit operation for an imbalance exceeding 12% at 208 VAC and 8% at 460 VAC.

FIGURE 24
LED Fault Illumination

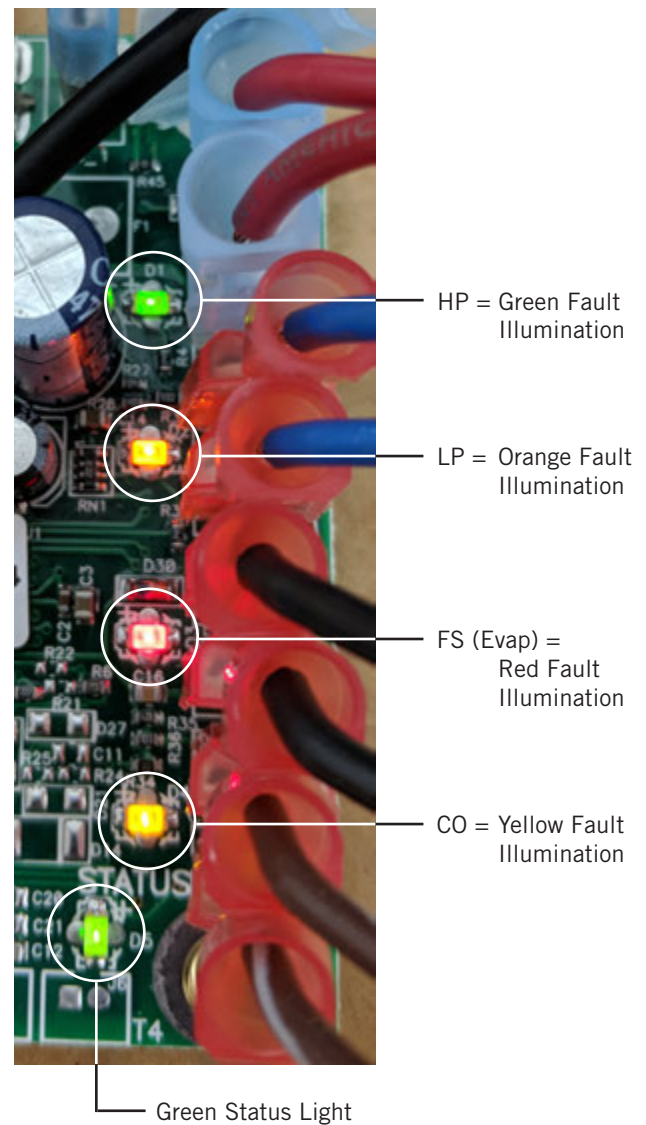

If a fault condition occurs, reverse two of the supply leads to the unit. **Do not reverse any of the unit factory wires as damage may occur.**

Refrigerant Leak Detection System (RDS)

The RDS continuously monitors air in the indoor section of the unit for leaked refrigerant. In the event of a refrigerant leak, the RDS will initiate mitigation actions to disperse the refrigerant and prevent potentially dangerous refrigerant concentration levels. The RDS will also provide a 24VAC alarm output signal on the "L" terminal of the unit low-voltage terminal strip.

Refer to page 47 for more information.

Condenser Fan Operation

NOTE: *Certain models may be equipped with a low ambient control (LAC), and if so, the condenser fan motor will have a delayed start until system refrigerant operating pressure builds up. After starting, the fan motor may or may not cycle depending upon ambient conditions. This is normal operation.*

Sequence of Operation

With Y1-Y2 jumpers installed, circuit R-Y1 makes at thermostat pulling in compressor contactor, starting the compressor, indoor blower (rated air) and outdoor motor. (See **NOTE** under **Condenser Fan Operation** concerning models equipped with low ambient control.) The G (indoor motor) circuit is automatically completed by the thermostat on any call for cooling operation or can be energized by manual fan switch on subbase for constant air circulation.

On a call for heating, circuit R-B/W1 makes at the thermostat pulling in the heat contactor for the strip heat and blower operation. On a call for emergency heat, R-W2 makes, bringing on second heat contactor, if so equipped.

Balanced Climate™ Mode

Balanced Climate™ is a great comfort feature that can easily be applied under any normal circumstances. If the Bard air conditioning system is being set up in a typical environment where 72°F is the lowest cooling setpoint, remove the Y1/Y2 jumpers from the upper and lower low voltage strips and install a 2-stage cooling thermostat. This will increase the humidity removal up to 35% and provide a much more comfortable environment. This mode will also increase the supply temperature when in heating mode. When Balanced Climate mode is activated, it is employed in both heating and cooling modes.

Balanced Climate can readily be applied to duct-free (supply and return air grille) applications. It may also be applied to ducted applications with **limited static of 0.20" ESP (total including both supply and return statics)**. Consult Bard Application Engineering for details prior to implementation.

CAUTION: *Balanced Climate is not a replacement for a dehumidification (hot gas reheat) unit for extreme applications, but rather an enhancement feature for limited climates and applications.*

Troubleshooting ECM™ 142R Outdoor Fan Motors

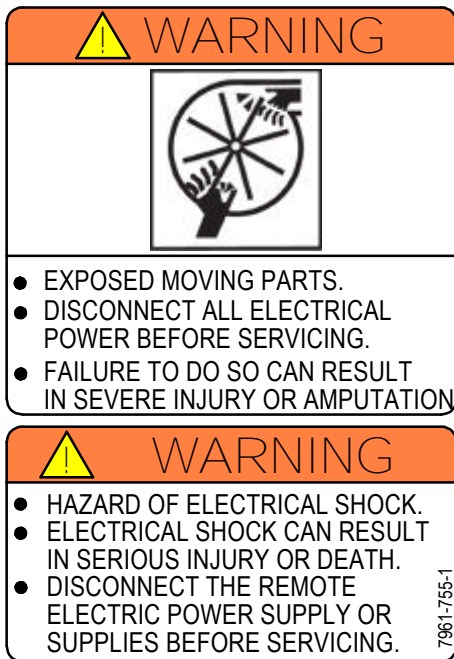

CAUTION

Do not operate motor without fan blade attached. Such operations will cause the motor to oscillate up and down.

CAUTION

Only use the correct replacement motor from the manufacturer that is a direct replacement for the failed motor.

USING THE WRONG MOTOR VOIDS ALL WARRANTIES AND MAY PRODUCE UNEXPECTED RESULTS.

1. In normal operation, this motor may rock back and forth on start up. Do not replace if this is the only symptom identified.
2. If the system is operating properly, but the motor appears to run slower than it should, the motor is good. High efficiency systems with optimized fan blades are engineered to run slow to decrease noise. The Bard Q-TEC Series models also adjust fan speed based upon varied outdoor ambient conditions to optimize sound and unit efficiency.
3. If the system is noisy, freezing up, running a high head pressure, tripping the high pressure switch or compressor overload, check the following:
 - a. Ensure cleanliness of condenser coil(s) and fan blade/shroud.
 - b. Confirm the fan blade is not bent or deformed, isn't rubbing on the shroud and that it is tight on the motor shaft. Also ensure the motor is secure in its mounting system, and the mounting system is secure to the unit.
 - c. The Bard Q-TEC may be equipped with a low ambient control pressure switch. This pressure switch completes the 24VAC common feed to the outdoor fan motor control in cooling mode. If this switch is defective, the outdoor air temperature is too cold to raise the head pressure to the 325# switch closing set point or the system charge is too low, this could be the cause of the issue.
 - d. If motor is not running, go to next section.
4. If the motor does not appear to be running at the proper speed or does not shut off, refer to the next section for voltage checks to determine if the motor is getting the proper input signals.

If the motor IS NOT receiving any communication, troubleshoot the communication issue using the diagnostic table for the fan logic control.

 - a. Power is connected to motor leads
High Voltage:
Brown connects to L1
Black connects to L2
Green connects to ground
 - b. This motor uses a 24v signal to cycle fan operation
Blue connects to C1 on compressor logic control board
Yellow connects to either the optional LAC switch or the compressor contactor

Replacing the Motor

This motor is replaced in one piece. The control cannot be replaced separately from the motor. Even if the control is remotely located, the replacement part will be a new control with harness and new motor.

The correct replacement motor from the manufacturer that is a direct replacement for the failed motor must be used.

Using the wrong motor voids all product warranties and may produce unexpected results.

Always mount the replacement motor and control according to the manufacturers specifications using all required hardware to reduce vibration. Make sure all wires are free of the fan blade and not pinched in mountings or cabinet through points.

TABLE 5
Troubleshooting ECM™ 142R Outdoor Fan Motors

Check line power to motor	Check between brown and black wires for line power.
	Verify ground by checking green wire to L1 and L2 line power.
Check for 24VAC common signal to motor (against transformer "R" signal)	Check yellow/red wire from CC on logic board to compressor contactor.
	Not energized in cooling mode until low ambient fan cycling control is closed by 350 PSIG refrigerant pressure.
	Fan should run when compressor contactor coil is energized, unless low ambient switch control is open.

Troubleshooting ECM™ Indoor Blower Motors

CAUTION: Disconnect power from unit before removing or replacing connectors, or servicing motor. To avoid electric shock from the motor's capacitors, disconnect power and wait at least 5 minutes before opening motor.

Symptom	Cause/Procedure
Motor rocks slightly when starting	This is normal start-up for ECM
Motor won't start: No movement	Check blower turns by hand Check power at motor Check low voltage (24 Vac R to C) at motor Check low voltage connections (G, R, C) at motor Check for unseated pins in connectors on motor harness (see Table 6 on page 44) Test with a temporary jumper between R - G Check motor for tight shaft Perform motor/control replacement check Perform Moisture Check
Motor won't start: Motor rocks but won't start	Check for loose or compliant motor mount Make sure blower wheel is tight on shaft Perform motor/control replacement check
Motor oscillates up and down while being tested off of blower	It is normal for motor to oscillate with no load on shaft
Motor starts but runs erratically: Varies up or down or intermittent	Check line voltage for variation or "sag" Check low voltage connections (G, R, C) at motor, unseated pins in motor harness connectors Check out system controls, thermostat Perform Moisture Check
Motor starts but runs erratically: "Hunts" or "puffs"	Does removing panel or filter reduce "puffing"? - Reduce restriction
Motor starts but runs erratically: Blower won't shut off	Current leakage from controls into G, Y? - Check for Triac-switched thermostat or solid-state relay
Excessive noise	Determine if it's air noise, cabinet, duct or motor noise; interview customer, if necessary
Excessive noise: Air noise	High static creating high blower speed? - Is airflow set properly? - Does removing filter cause blower to slow down? Check filter - Use low-pressure drop filter - Check/correct duct restrictions
Excessive noise: Noisy blower or cabinet	Check for loose blower housing, panels, etc. High static creating high blower speed? - Check for air whistling through seams in ducts, cabinets or panels - Check for cabinet/duct deformation
Evidence of Moisture: Motor failure or malfunction has occurred and moisture is present	Replace motor and Perform Moisture Check
Evidence of Moisture: Evidence of moisture present inside air mover	Perform Moisture Check

Do's and Dont's	
Do	Don't
Check out motor, controls, wiring and connections thoroughly before replacing motor	Automatically assume motor is bad
Orient connectors down so water can't get in - Install "drip loops"	Locate connectors above 8 and 4 o'clock positions
Use authorized motor and model #s for replacement	Replace one motor or control model # with another (unless an authorized replacement)
Keep static pressure to a minimum: - Recommend high efficiency, low static filters - Recommend keeping filters clean - Design ductwork for minimum static, maximum comfort - Look for and recommend ductwork improvement, where necessary	Use high pressure drop filters—some have ½" WC drop! Use restricted returns
Size equipment wisely	Oversize system then compensate with low airflow
Check orientation before inserting motor connectors	Plug in power connector backwards Force plug

Moisture Check

- Connectors are oriented "down" (or as recommended by equipment manufacturer)
- Arrange harness with "drip loop" under motor
- Is condensate drain plugged?
- Check for low airflow (too much latent capacity)
- Check for undercharged condition
- Check and plug leaks in return ducts, cabinet

Comfort Check

- Check proper airflow settings
- Low static pressure for lowest noise
- Thermostat in bad location?

Replacing ECM Control Module

The following steps must be taken to replace the control module for the GE variable-speed indoor blower motor:

1. MUST have the correct replacement module. The controls are factory programmed for specific operating modes. Even though they look alike, different modules may have completely different functionality.
Using the wrong control module voids all product warranties and may produce unexpected results.
2. Begin by removing AC power from the unit being serviced. **Do not work on the motor with AC power applied.** To avoid electric shock from the motor's capacitors, disconnect power and wait at least 5 minutes before opening motor.
3. It is not necessary to remove the motor from the blower assembly, nor the blower assembly from the unit. Unplug the two cable connectors to the motor control assembly. There are latches on each connector. **Do not pull on the wires.** The plugs remove easily when properly released.
4. Locate the screws that retain to the motor control bracket to the sheet metal of the unit and remove them. Remove two (2) nuts that retain the control to the bracket and then remove two (2) nuts that retain sheet metal motor control end plate (see Figure 25).
5. Using thumb and forefinger to squeeze the latch tab and the opposite side of the connector plug and gently pulling the connector, disconnect the three (3) wires interior of the motor control. **Do not pull on the wires; grip the plug only.** See Figure 25.
6. The control module is now completely detached from the motor. Verify with a standard ohmmeter the motors winding resistance:
 - A. Measure that there is resistance between pins 1 to 2, 1 to 3 and 2 to 3. The readings should not be 0 ohms and all three measurements should be within $\pm 10\%$ of each other. Move to step B if the windings resistance are within range. **If any motor lead fails this test, the motor is defective and must be replaced.**
 - B. Test that each lead to the motor shell is $>100K$ ohms (see Figure 26). (Take measurement to unpainted motor end plate.) **If any motor lead fails this test, the motor is defective and must be replaced.**

NOTE: *Installing the new control module will cause it to fail also.*

7. Verify that the replacement control is correct for the application. Refer to the manufacturer's authorized replacement list. **Using the wrong control will result in improper or no blower operation.** Orient the control module so that the 3-wire motor plug can be inserted into the socket in the control. Carefully insert the plug and press it into the socket until it latches. **A slight click will be heard when properly inserted.**
8. Reverse Steps #5, 4 and 3 to reconnect the motor control to the motor wires, securing the motor control cover plate, mounting the control to the bracket and mounting the motor control bracket back into the unit. **Make sure the orientation selected for replacing the control ensures the control's cable connectors will be located downward in the application so that water cannot run down the cables and into the control. Do not overtighten the bolts.**
9. Plug the 16-pin control plug into the motor. The plug is keyed. Make sure the connector is properly seated and latched.
10. Plug the 5-pin power connector into the motor. Even though the plug is keyed, **observe the proper orientation. Do not force the connector.** It plugs in very easily when properly oriented. **Reversing this plug will cause immediate failure of the control module.**
11. Final installation check. Make sure the motor is installed as follows:
 - A. Motor connectors should be oriented between the 4 o'clock and 8 o'clock positions when the control is positioned in its final location and orientation.
 - B. Add a drip loop to the cables so that water cannot enter the motor by draining down the cables (see Figure 27).

The installation is now complete. Reapply AC power to the HVAC equipment and verify that the new motor control module is working properly. Follow the manufacturer's procedures for disposition of the old control module.

FIGURE 25
Control Disassembly

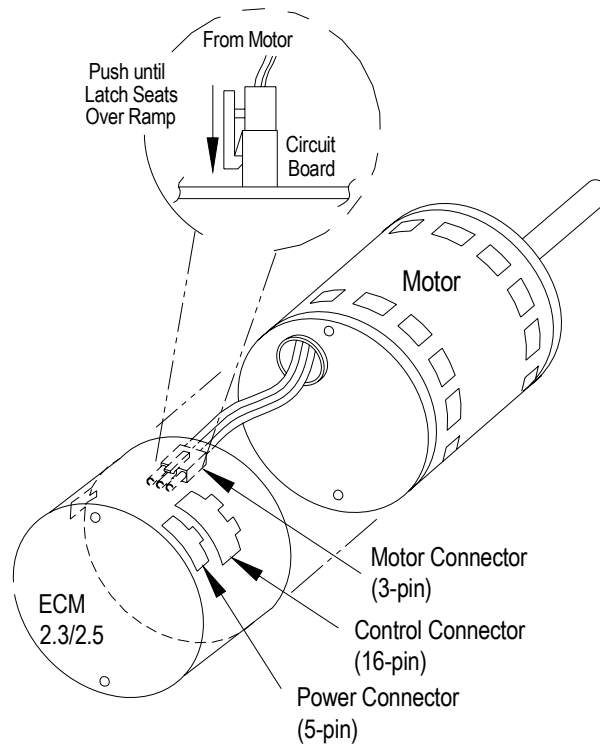

FIGURE 26
Winding Test

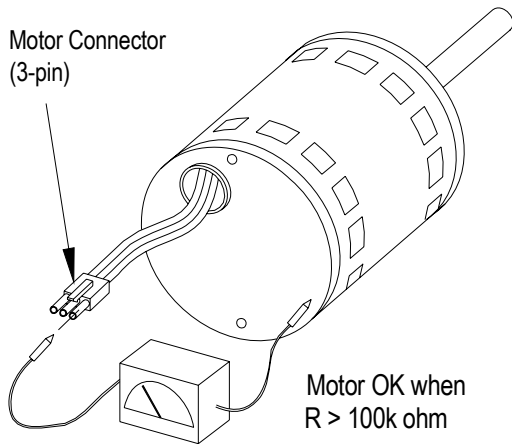

FIGURE 27
Drip Loop

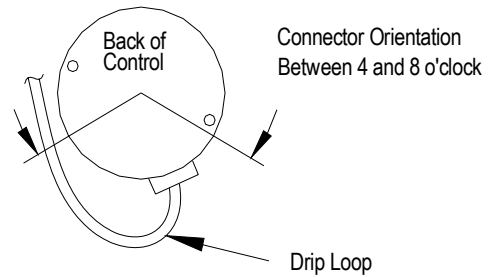
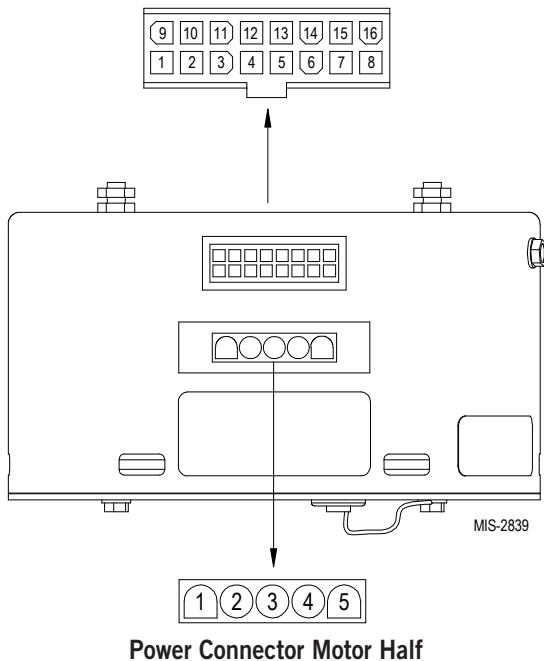

TABLE 6
Troubleshooting ECM™ Indoor Blower Motors

Mode of Operation	OFF	Continuous Blower (Ventilation Mode)	Part Load Cooling ("Y1-Y2" Jumper Removed)	Full Load Cooling	Dehum. Mode	Heat 1st Bank of Elec. Heat	Heat 1st & 2nd Bank of Elec. Heat
Thermostat 24 VAC Input Signals	—	"G"	"G", "Y1"	"G", "Y1", "Y2"	"D"	"G", "B/W1"	"G", "B/W1", "W2"
Pin #1	24 VAC "C" (Common) Signal, Always Energized						
Pin #2	Not Used						
Pin #3	24 VAC "C" (Common) Signal, Always Energized						
Pin #4	Not Used						
Pin #5	Not Used						
Pin #6			X	X	X		
Pin #7	Not Used						
Pin #8	Not Used						
Pin #9						X	X
Pin #10			X	X	X	X	X
Pin #11	Not Used						
Pin #12	24 VAC Hot "R" Signal, Always Energized						
Pin #13						X	X
Pin #14				X			
Pin #15		X	X	X		X	X
Pin #16	Not Used						

FIGURE 28
Control Connector Motor Half



Power Connector	
PWB Header	AMP 1-350945-0
PIN	Description
1	Jumper Pin 1 to Pin 2 for 120VAC Line Input Only **
2	
3	Chassis Ground
4	AC Line
5	AC Line

* Suggested mating connector
Housing — AMP 350809-1
Contact — AMP 350537-1

** **WARNING** – Applying 240VAC line input with PIN 1 to PIN 2 jumper in place **will permanently damage unit!**

Fan Blade Setting Dimensions

The correct fan blade setting for proper air delivery across the outdoor coil is shown in Figure 29. Refer to Table 7 for unit specific dimension.

Any service work requiring removal or adjustment in the fan and/or motor area will require that the dimensions below be checked and blade adjusted in or out on the motor shaft accordingly.

FIGURE 29
Fan Blade Setting

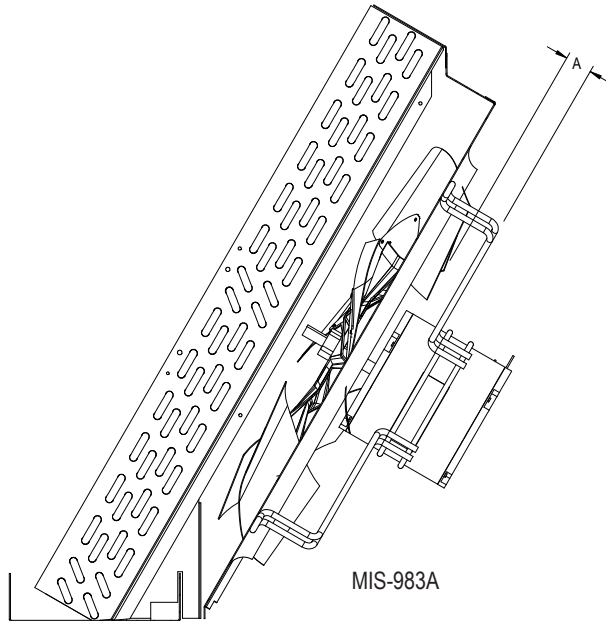

TABLE 7
Fan Blade Dimensions

Model	Dimension A
Q36AF Q42AF Q48AF	.50"

R-454B Refrigerant Charge

This unit was charged at the factory with the quantity of refrigerant listed on the serial plate. AHRI capacity and efficiency ratings were determined by testing with this refrigerant charge quantity.

The pressure tables found on page 46 show nominal pressures for the units. Since many installation specific situations can affect the pressure readings, this information should only be used by certified technicians as a guide for evaluating proper system performance. They shall not be used to adjust charge. If charge is in doubt, recover, evacuate and recharge the unit to the serial plate charge.

Removal of Fan Shroud

1. Disconnect all power to the unit before servicing.
2. The unit can be rolled into the room, or the wall sleeve louver can be removed from outside of the building to access the condenser coil for cleaning or to service the outdoor fan.
3. The fan shroud and motor assembly can be removed from the unit by four (4) screws and the coil top fill, then the six (6) screws from the shroud sides. Fan motor must be unplugged from motor controller. The assembly can now be lifted/slid out from the condenser section (see Figure 30).
4. The fan assembly or coil can now be serviced.
5. Reverse the steps to reassemble.

FIGURE 30
Fan Shroud Removal

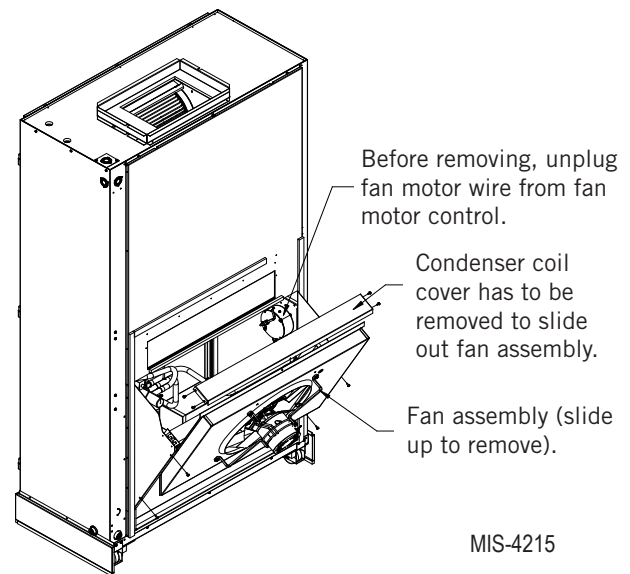

TABLE 8A
Cooling Pressure – Standard Airflow

Air Temperature Entering Outdoor Coil °F

Model	Return Air Temp (DB/WB)	Pressure	75	80	85	90	95	100	105	110	115	120	125
Q36AFD	75/62	Low Side	122	123	124	125	126	127	128	129	131	132	133
		High Side	306	329	352	375	400	424	450	476	502	529	557
	80/67	Low Side	131	132	133	134	135	136	137	138	140	141	142
		High Side	314	337	361	385	410	435	461	488	515	543	571
	85/72	Low Side	135	136	137	138	139	141	142	143	145	146	147
		High Side	325	349	373	398	424	450	477	505	533	562	591
Q42AFD	75/62	Low Side	121	122	123	125	126	127	129	130	131	132	134
		High Side	322	345	367	391	415	440	466	492	519	546	575
	80/67	Low Side	129	131	132	134	135	136	138	139	140	142	143
		High Side	331	353	377	401	426	451	478	504	532	560	589
	85/72	Low Side	134	135	137	138	140	141	143	144	145	147	148
		High Side	342	366	390	415	441	467	494	522	551	580	610
Q48AFD	75/62	Low Side	120	120	120	121	122	123	124	126	127	129	131
		High Side	308	326	346	366	388	410	433	457	482	508	535
	80/67	Low Side	128	128	129	129	130	131	133	134	136	138	140
		High Side	316	335	355	376	398	420	444	469	494	521	549
	85/72	Low Side	132	133	133	134	135	136	137	139	141	143	145
		High Side	327	347	367	389	411	435	460	485	512	539	568

Low side pressure ± 4 PSIG/High side pressure ± 10 PSIG

TABLE 8B
Cooling Pressure – Balanced Climate Airflow

Air Temperature Entering Outdoor Coil °F

Model	Return Air Temp (DB/WB)	Pressure	75	80	85	90	95	100	105	110	115	120	125
Q36AFD	75/62	Low Side	110	112	113	114	116	117	118	119	121	122	123
		High Side	296	320	344	368	392	415	439	463	487	511	533
	80/67	Low Side	118	120	121	122	124	125	126	128	129	130	131
		High Side	304	329	353	377	401	425	450	474	498	522	545
	85/72	Low Side	123	124	125	127	128	129	131	132	134	135	136
		High Side	315	340	365	390	415	440	464	489	514	539	564
Q42AFD	75/62	Low Side	108	110	112	113	115	117	119	121	123	125	126
		High Side	312	337	363	388	414	439	465	490	516	541	567
	80/67	Low Side	115	117	119	121	123	125	127	129	131	133	135
		High Side	321	346	372	398	424	450	476	502	528	554	581
	85/72	Low Side	120	122	124	126	128	130	132	134	136	138	140
		High Side	331	358	385	411	438	465	492	519	546	573	602
Q48AFD	75/62	Low Side	112	113	115	116	117	119	120	121	122	124	124
		High Side	300	323	346	369	392	415	438	461	484	507	528
	80/67	Low Side	119	121	122	123	125	126	128	129	130	132	132
		High Side	307	330	354	377	401	425	448	472	495	519	541
	85/72	Low Side	122	124	125	127	128	130	131	133	134	135	136
		High Side	318	342	366	390	415	439	463	487	511	536	559

Low side pressure ± 4 PSIG/High side pressure ± 10 PSIG

Tables are based upon rated CFM (airflow) across the evaporator coil. If there is any doubt as to correct operating charge being in the system, the charge should be removed and system evacuated and recharged to serial plate charge weight.

NOTE: Pressure table based on high speed condenser fan operation. If condensing pressures appear elevated check condenser fan wiring. See **Condenser Fan Operation** on page 38.

Refrigerant Leak Detection System (RDS)

This unit is equipped with a refrigerant leak detection system (RDS). This system monitors the air in the indoor section of the unit for refrigerant leaks. In the event of a leak, the RDS will enter mitigation mode, which prohibits function of the compressor and electric heaters (if applicable) and turns on the indoor blower in order to prevent the refrigerant from concentrating within the unit. The RDS is made up of three major

components: Refrigerant sensor, RDS harness and DPDT relay (see Figure 31).

Why RDS?

R-454B refrigerant carries an "A2L" safety classification, meaning it is mildly flammable in certain concentrations. The purpose of the RDS is to prevent refrigerant from reaching potentially dangerous concentrations within the indoor section of the unit in the event of a refrigerant leak.

FIGURE 31
Refrigerant Leak Detection System

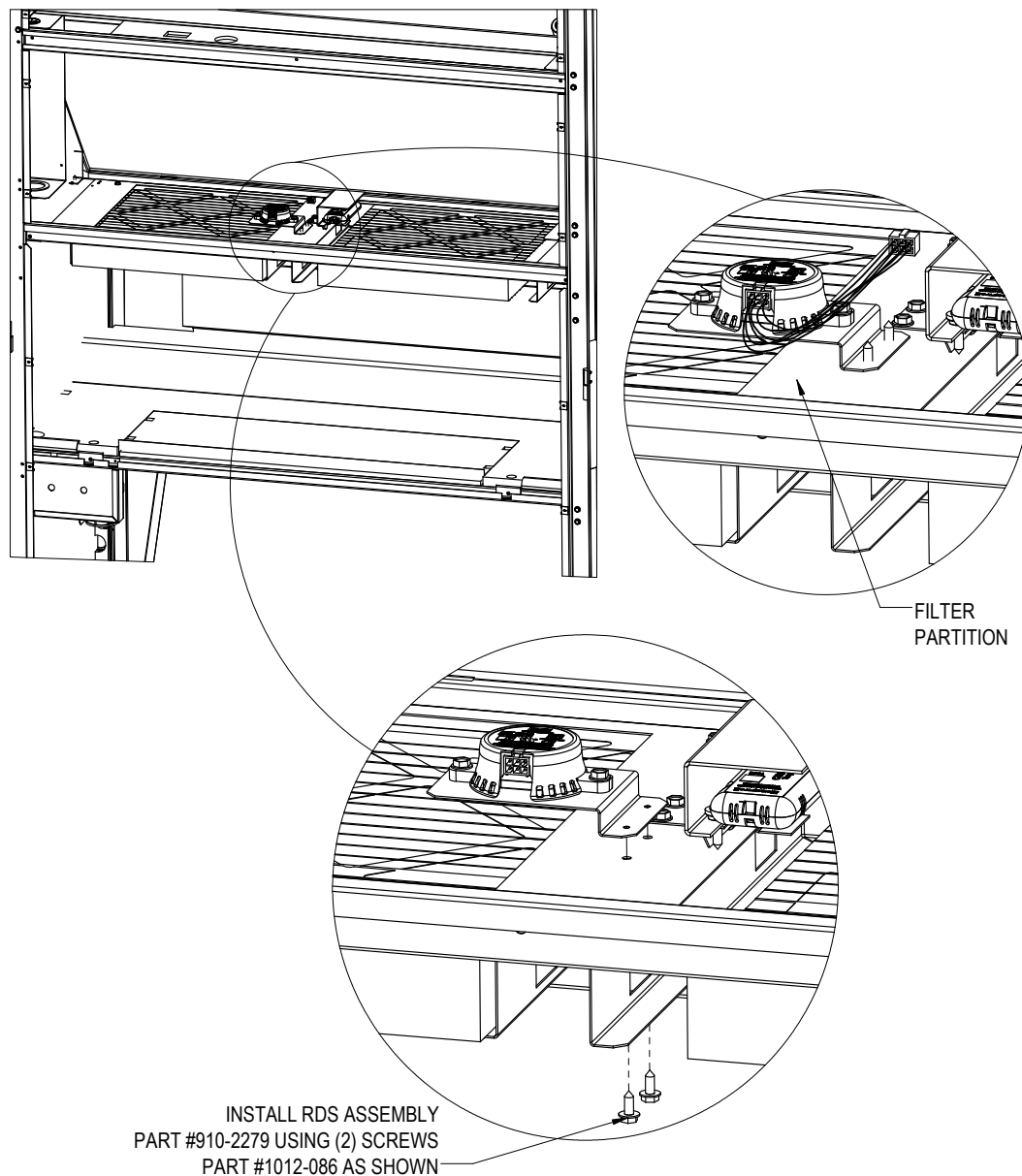

MIS-4543

Sequence of Operations

The refrigerant sensor has four operating modes: Power up and self test, normal, alarm state and sensor fault. During all modes of operation the sensor will continue to perform runtime diagnostics.

Power Up and Self Test

When the air conditioner receives power, the refrigerant sensor executes a series of self test diagnostics. This validates the integrity of the sensor's memory, embedded program, and power supply. This power up sequence only takes a few seconds.

Normal Operation

Once the refrigerant sensor's power up sequence is complete, the RDS begins normal operation. In this mode the refrigerant sensor is active and the air conditioner functions normally.

Alarm State

The refrigerant sensor has a factory-set alarm threshold limit value. When the sensor registers refrigerant at a concentration above this threshold, the sensor enters alarm state. In alarm state the internal relay within the refrigerant sensor is de-energized, which puts the RDS into mitigation mode.

Sensor Fault Mode

The refrigerant sensor performs continuous diagnostics on the sensor integrity (shorts, opens, out of range, communication errors) as well as the integrity of the on-board memory, programming, oscillator and voltage levels. If any of these diagnostics fail or the sensor becomes disconnected, the internal relay within the refrigerant sensor is de-energized, which puts the RDS into mitigation mode.

Mitigation Mode

When the RDS enters mitigation mode, it initiates the following:

- The "G" terminal is energized on the low voltage terminal strip. This activates the indoor blower.
- The signal from "CC" on the defrost board to the compressor contactor is interrupted. This stops compressor operation or prevents it from starting in the event of a call from the thermostat
- The 24V common connection to all electric heat contactors (if applicable) is broken. This stops electric heat operation or prevents it from starting in the event of a heating call
- The "L" terminal on the low voltage terminal strip is energized. This output may be used to trigger an external alarm or notify a building management system or group controller that a leak has occurred.

Alarm Reset





The refrigerant sensor will stay in alarm mode as long as the refrigerant concentration remains above the alarm threshold limit value. For the alarm to be reset, the sensor reading must be a minimum of 2.5% below the alarm threshold for a period of 5 minutes. The relay is then re-energized, and the unit returns to normal operation.

RDS Diagnosis

The refrigerant sensor of the RDS features a status LED. When the sensor is powered up, an LED will indicate sensor status. The sensor LED will back-light the sensor and create a visible reflection on the blower partition. Status LED blink codes shown in Figure 32.

NOTE: *If the sensor status LED is not lit, the sensor is either not receiving power or may be faulty or damaged. Check harness connections and test internal relay. Refer to A2L Safety Manual 2100-810 for additional diagnostic information.*

FIGURE 32
Sensor Status LED Blink Code

	Solid Green: Sensor Power Up and Self Test
	Blinking Green: Normal Operation
	Solid Red: Alarm State – Gas Detection
	Blinking Red: Sensor Fault



Sensor End-of-Life

The refrigerant sensor has a rated life expectancy of 15+ years. This is not a set time length, but it is the expected time that the sensor should last without failing its internal checks. In the event that the sensor would reach its end-of-life, it will enter Sensor Failure Mode and the sensor will need to be replaced. **The sensor must be replaced with a Bard-approved refrigerant sensor.** See unit replacement parts manual for the correct replacement sensor information.

FIGURE 33
Refrigerant Leak Detection System (RDS) Troubleshooting

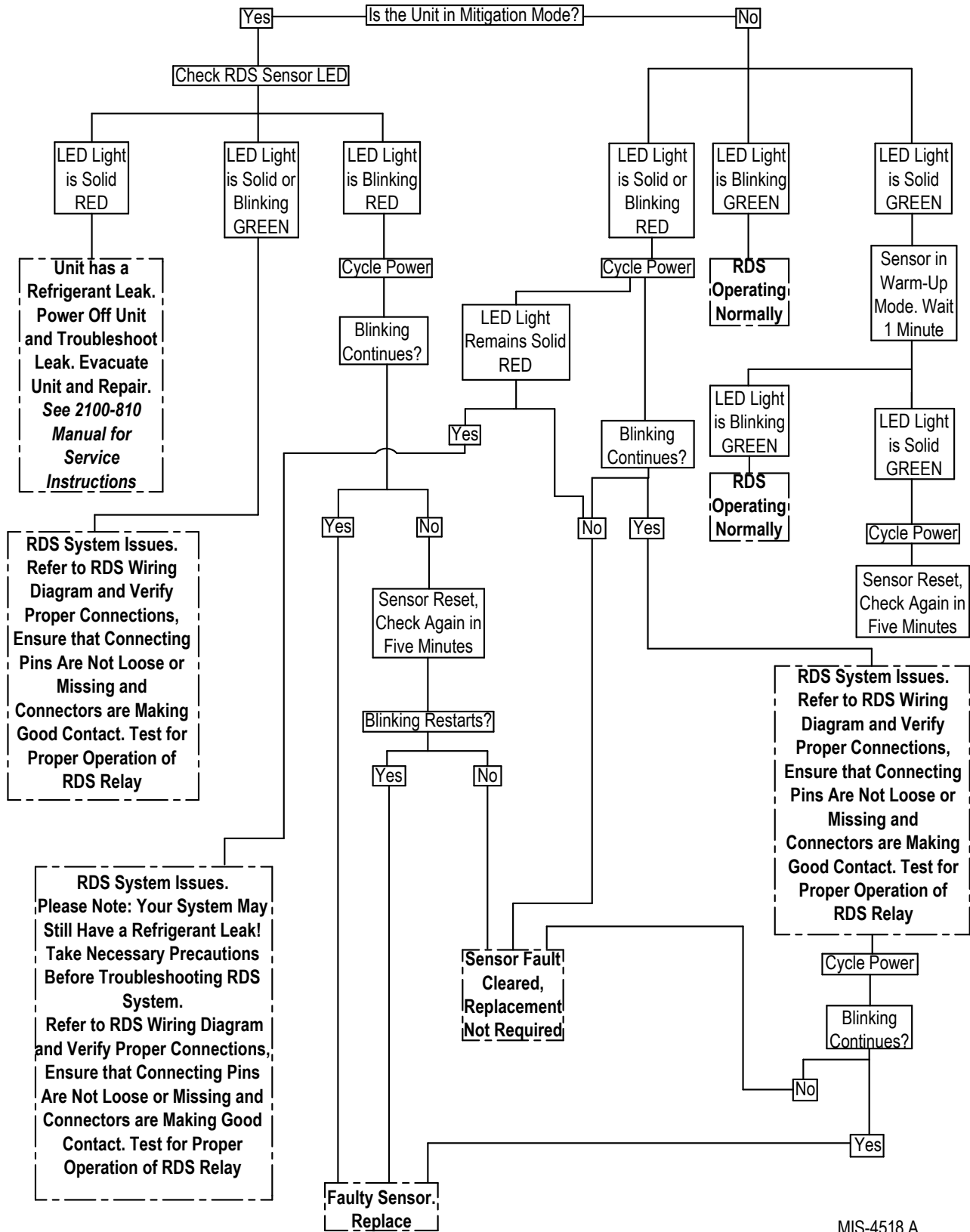

MIS-4518 A

FIGURE 34
Refrigerant Leak Detection System (RDS) Wiring Diagram

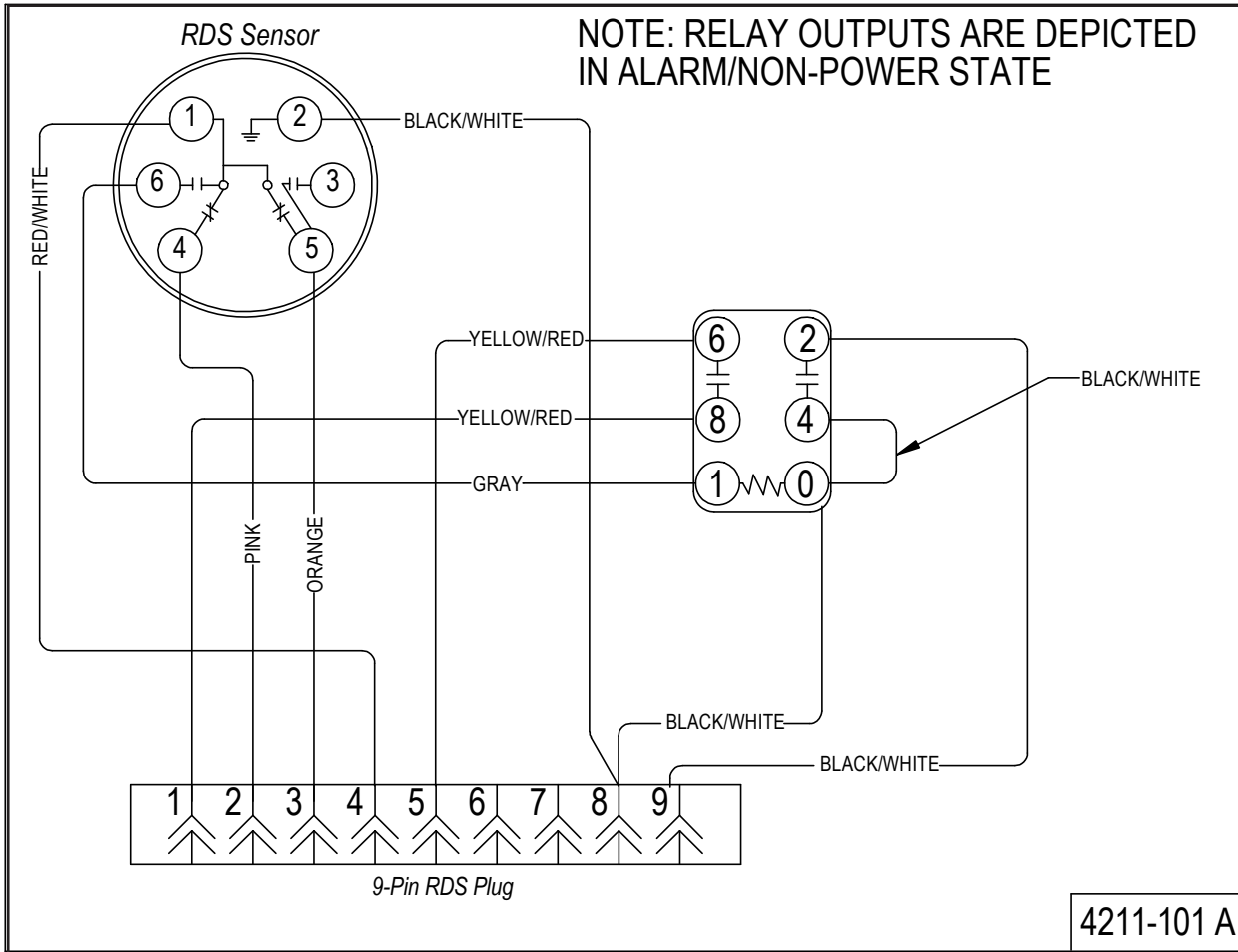

TABLE 9
Electrical Specifications – QAFD Series**

Model	Rated Volts & Phase	No. Field Power Circuits	Single Circuit		Multiple Circuit			
			① Minimum Circuit Ampacity	② Maximum External Fuse or Circuit Breaker	① Minimum Circuit Ampacity		② Maximum External Fuse or Circuit Breaker	
					Ckt. A	Ckt. B	Ckt. A	Ckt. B
Q36AFDA0Z -A05 -A10	230/208-1	1 1 1	28 31 57	35 35 60				
Q36AFDB0Z -B06 -B09 -B15	230/208-3	1 1 1 1	23 23 32 51	30 30 35 60				
Q36AFDC0Z -C06 -C09 -C15	460-3	1 1 1 1	11 12 16 25	15 15 20 25				
Q42AFDA0Z -A05 -A10	230/208-1	1 1 1	31 32 58	35 35 60				
Q42AFDB0Z -B06 -B09 -B15	230/208-3	1 1 1 1	24 24 33 51	30 30 35 60				
Q42AFDC0Z -C06 -C09 -C15	460-3	1 1 1 1	11 12 17 26	15 15 20 30				
Q48AFDA0Z -A05 -A10 -A15	230/208-1	1 1 1 1 or 2	36 36 58 84	45 45 60 90	58	26	60	30
Q48AFDB0Z -B06 -B09 -B15	230/208-3	1 1 1 1	24 24 33 51	30 30 35 60				
Q48AFDC0Z -C06 -C09 -C15	460-3	1 1 1 1	12 12 17 26	15 15 20 30				

① These “Minimum Circuit Ampacity” values are to be used for sizing the field power conductors. Refer to the National Electrical code (latest version), Article 310 for power conductor sizing. **CAUTION:** When more than one field power circuit is run through one conduit, the conductors must be derated. Pay special attention to note 8 of Table 310 regarding Ampacity Adjustment Factors when more than three (3) current carrying conductors are in a raceway.

② Maximum size of the time delay fuse or circuit breaker for protection of field wiring conductors.

NOTE: The Maximum Overcurrent Protection (MOCP) value listed is the maximum value as per UL 60335 calculations for MOCP (branch-circuit conductor sizes in this chart are based on this MOCP). The actual factory-installed overcurrent protective device (circuit breaker) in this model may be lower than the maximum UL 60335 allowable MOCP value, but still above the UL 60335 minimum calculated value or Minimum Circuit Ampacity (MCA) listed.

IMPORTANT: While this electrical data is presented as a guide, it is important to electrically connect properly sized fuses and conductor wires in accordance with the National Electrical Code and all local codes.

TABLE 10
Indoor Blower Performance

Model	Rated ESP*	Maximum ESP*	Vent*	Rated CFM*	Balanced Climate CFM*
Q36AFD	0.15	0.5	1100	1150	800
Q42AFD	0.15	0.5	1300	1300	910
Q48AFD	0.20	0.5	1500	1500	1050

* These units are equipped with a variable speed (ECM) indoor motor that automatically adjusts itself to maintain approximately the same rate of indoor airflow in both heating and cooling, dry and wet coil conditions and at both 230/208 or 460 volts.

TABLE 11
Maximum ESP of Operation
Electric Heat Only

Model	All
Outlet	Top
Speed	Rated
-A0Z	.50
-A05	.50
-A10	.50
-A15	.50
-B0Z	.50
-B06	.50
-B09	.50
-B15	.50
-C0Z	.50
-C06	.50
-C09	.50
-C15	.50

Values shown are for units equipped with standard 1" throwaway filter or 1" washable filter.

Derate ESP by .15 for 2" pleated filters.

TABLE 12
Electric Heat

Nominal kW	At 230V ①				At 208V ①				At 460V		
	kW	1-Ph Amps	3-Ph Amps	BTUH	kW	1-Ph Amps	3-Ph Amps	BTUH	kW	3-Ph Amps	BTUH
5.0	4.6	20.0	11.5	15,700	3.8	18.0	10.4	12,800	4.6	5.8	15,700
6.0	5.5		13.9	18,800	4.5		12.5	15,400	5.5	6.9	18,800
9.0	8.3		20.8	28,300	6.8		18.7	23,000	8.3	10.4	28,300
10.0	9.2	40.0		31,400	7.5	36.1		25,600			
15.0	13.8	60.0	34.6	47,100	11.3	54.1	31.2	38,400	13.8	17.3	47,100

① These electric heaters are available in 230/208V units only.

GRAPH 1
Q36AFD FAD Ventilation Delivery

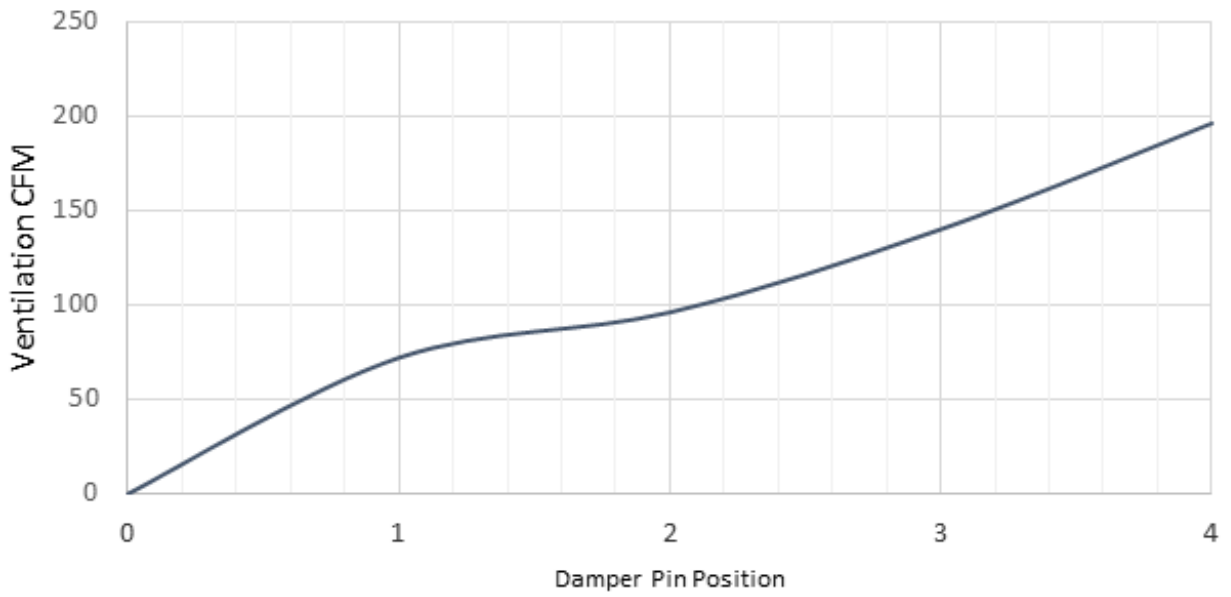

Constant CFM .10 Through .5 Static

GRAPH 2
Q42AFD FAD Ventilation Delivery

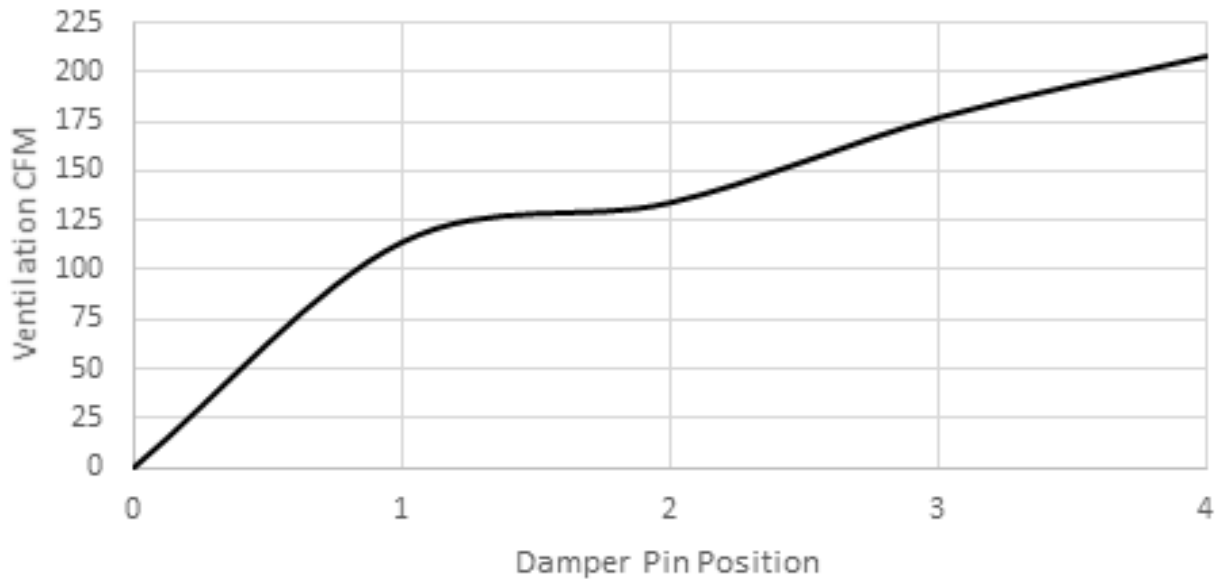

Constant CFM .10 Through .5 Static

GRAPH 3
Q48AFD FAD Ventilation Delivery

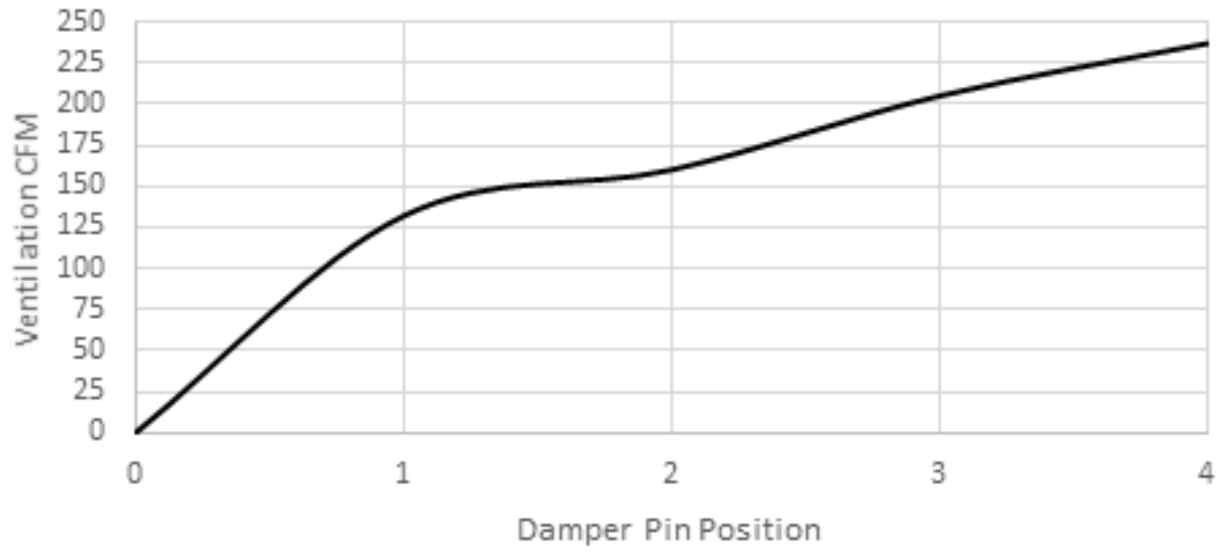

Constant CFM .10 Through .5 Static