

Climate Control Solutions

Bard Manufacturing Company, Inc.  
Bryan, Ohio 43506

# INSTALLATION INSTRUCTIONS

## CMH-3

### LOW PRESSURE CONTROL

#### DESCRIPTION

The CMH-3 is a field installable low pressure control.

The CMH-3 consists of:

1. Installation Instructions 7960-233A
2. Control Assembly 910-1095
3. Low Pressure Control 1804-0107
4. Unit Label 7961-312-0012

For use with all WH182 – WH602 Hi-Boy Wall Mount Heat Pumps.

#### INSTALLATION INSTRUCTIONS

Disconnect all power to unit. Remove control panel inner and outer covers, and right side condenser inlet grille. Circled numbers on Figure 2 correspond to installation instruction steps. Dashed lines indicate that a wire has been disconnected from this terminal and reconnected to another terminal.

Use Figure 2 for WH182 to WH361.

Use Figure 3 for WH421 to WH602.

- Step 1. Mount control assembly 910-1095 into control panel as shown with screws provided. See Figure 2 or 3, Step 1.
- Step 2. Disconnect blue high pressure control wire from heat pump control terminal LO and reconnect to terminal #1 of control assembly 910-1095. Route wires through wire holder as shown in Figure 2 or 3, Step 2.
- Step 3. Connect the blue wire from control assembly 910-1095 to LO terminal of the heat pump control. See Figure 2 or 3, Step 3.
- Step 4. Route low pressure control wires up through the bushing in the bottom of the control panel. Replace sealing compound after routing wires through the bushing. Route the wires through the wire holders in the control panel as shown in Figure 4. Connect the low pressure control wires between the terminals #1 and #3 of control assembly 910-10-9. See Figure 2 or 3, Step 4.
- Step 5. Connect the yellow wire from control assembly 910-1095 to Y terminal of the compressor contactor coil. This is the side of the contactor coil that the yellow wire is attached to. See Figure 2 or 3, Step 5.
- Step 6. Connect the black wire from control assembly 910-1095 to C terminal of the compressor contactor coil. This is the side of the contactor coil that the black wire is attached to. See Figure 2 or 3, Step 6.
- Step 7. Remove service port cap on the suction line. Install the low pressure switch on the suction line. Check for pressure at the flare tee dill valves after installation to insure that the dill valve in the unit service port was depressed by the flare tee connector. Check for leaks at the flare tee connectors. Replace service port cap on the flare tee service port and tighten. See Figure 4.
- Step 8. Recheck all wiring. See Figure 1. Check for proper operation of the unit by energizing in cooling mode. Run for five minutes. Unit should not go into lockout.
- Step 9. Apply "This unit equipped with CMH-3 control module" label to the inside of the inner control panel cover above the wiring diagram.
- Step 10. Replace all panels and covers. This completes installation.

FIGURE 1

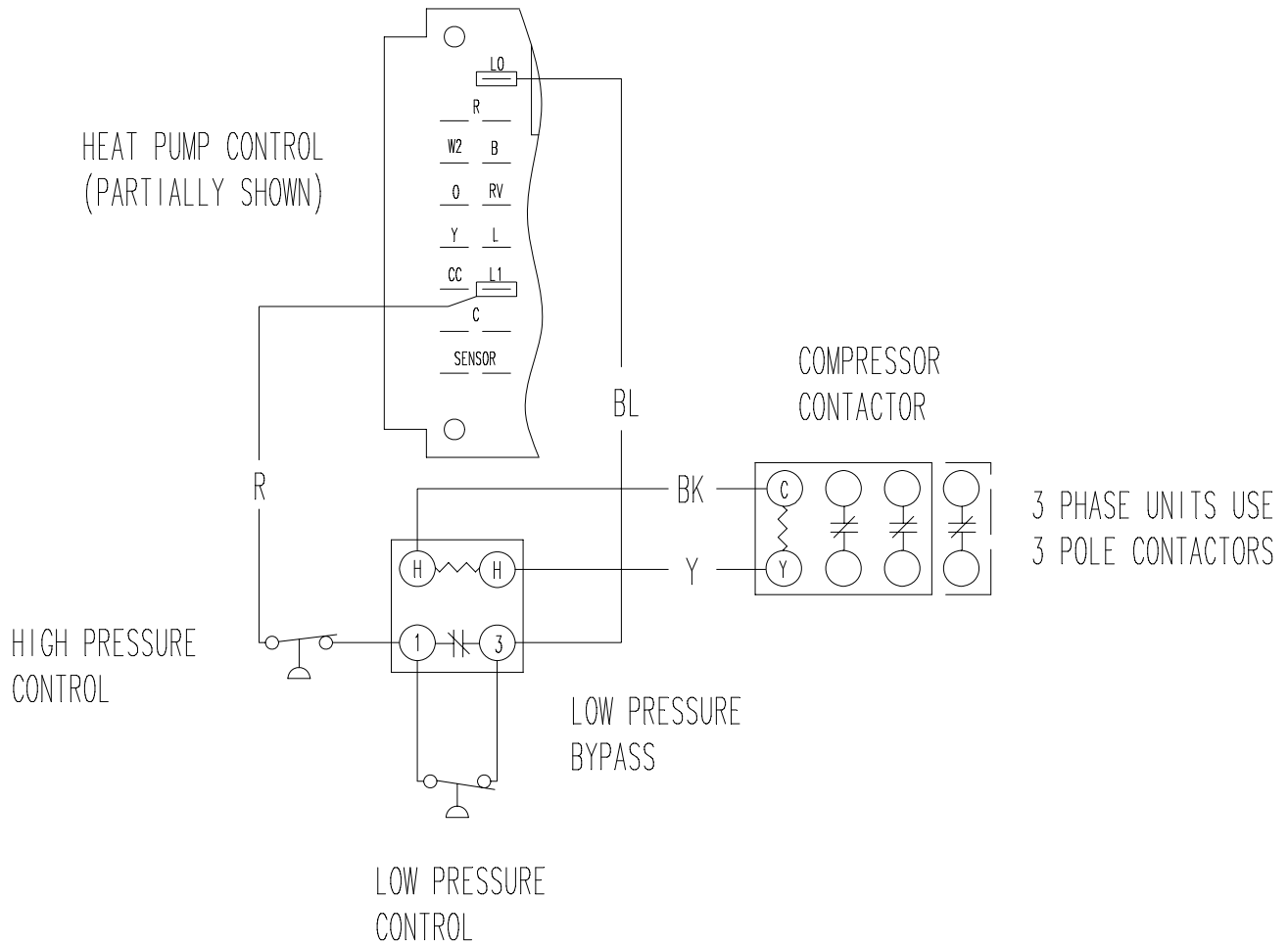

MIS-304

FIGURE 2

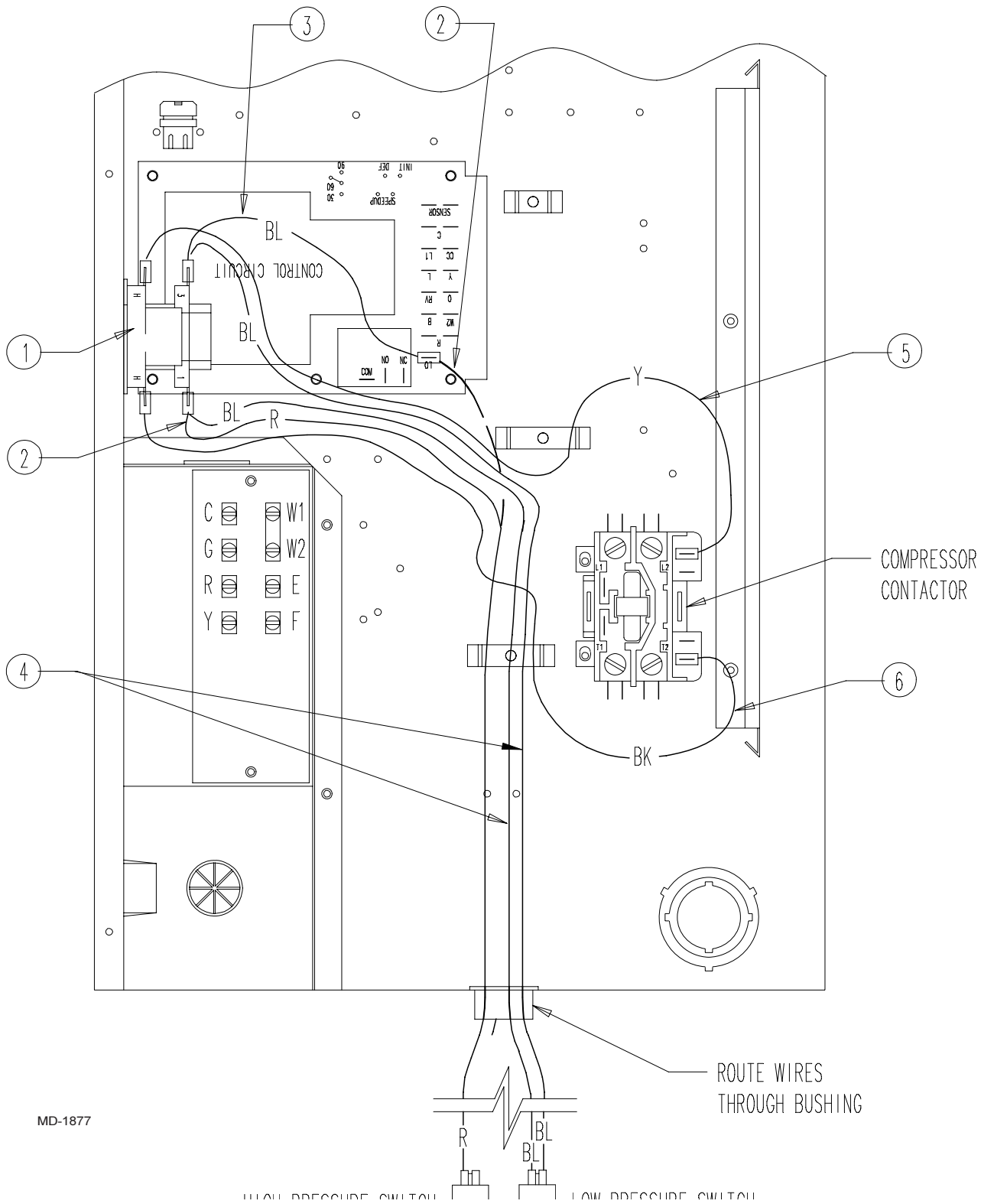

MD-1877

FIGURE 3

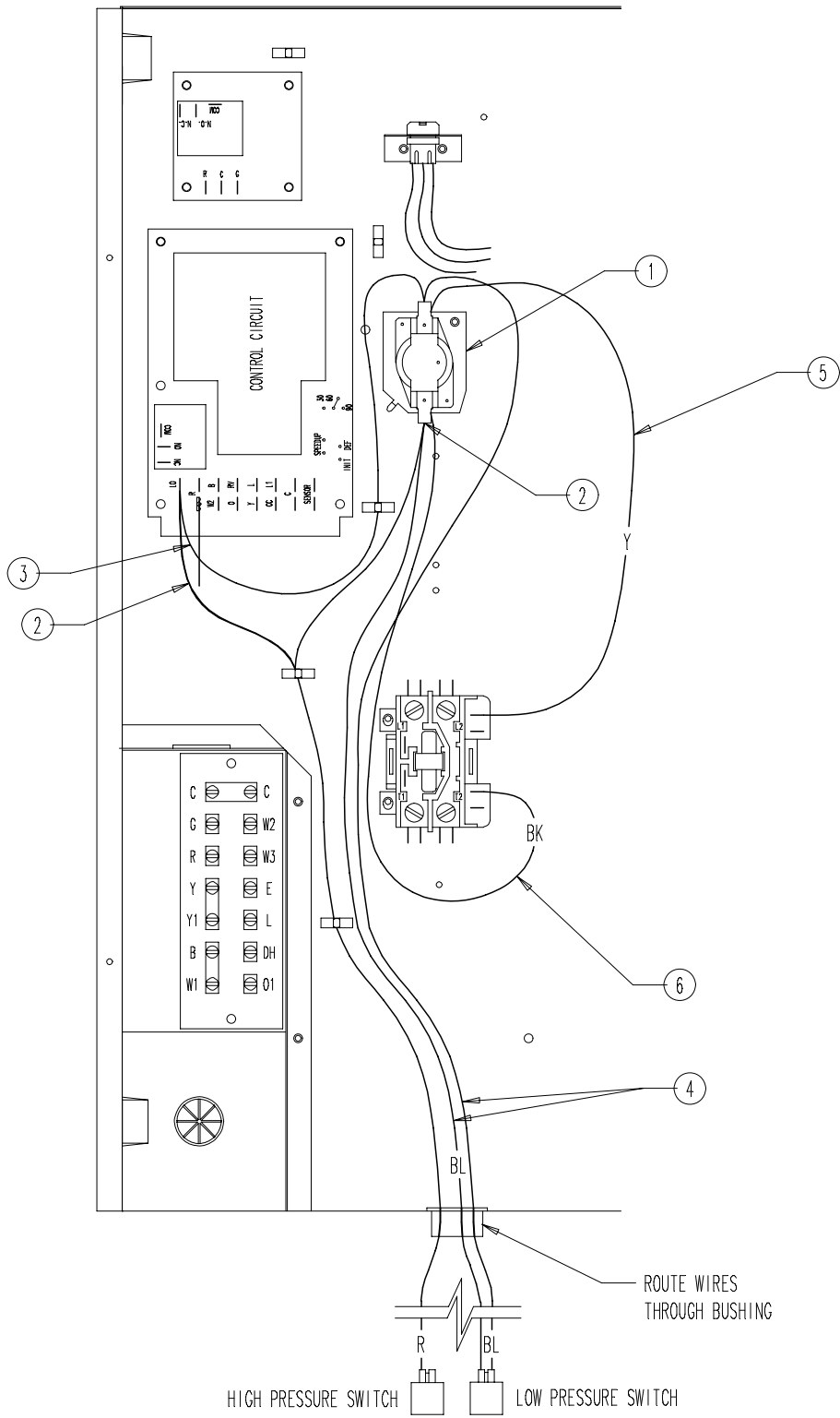

MIS-1391

FIGURE 4

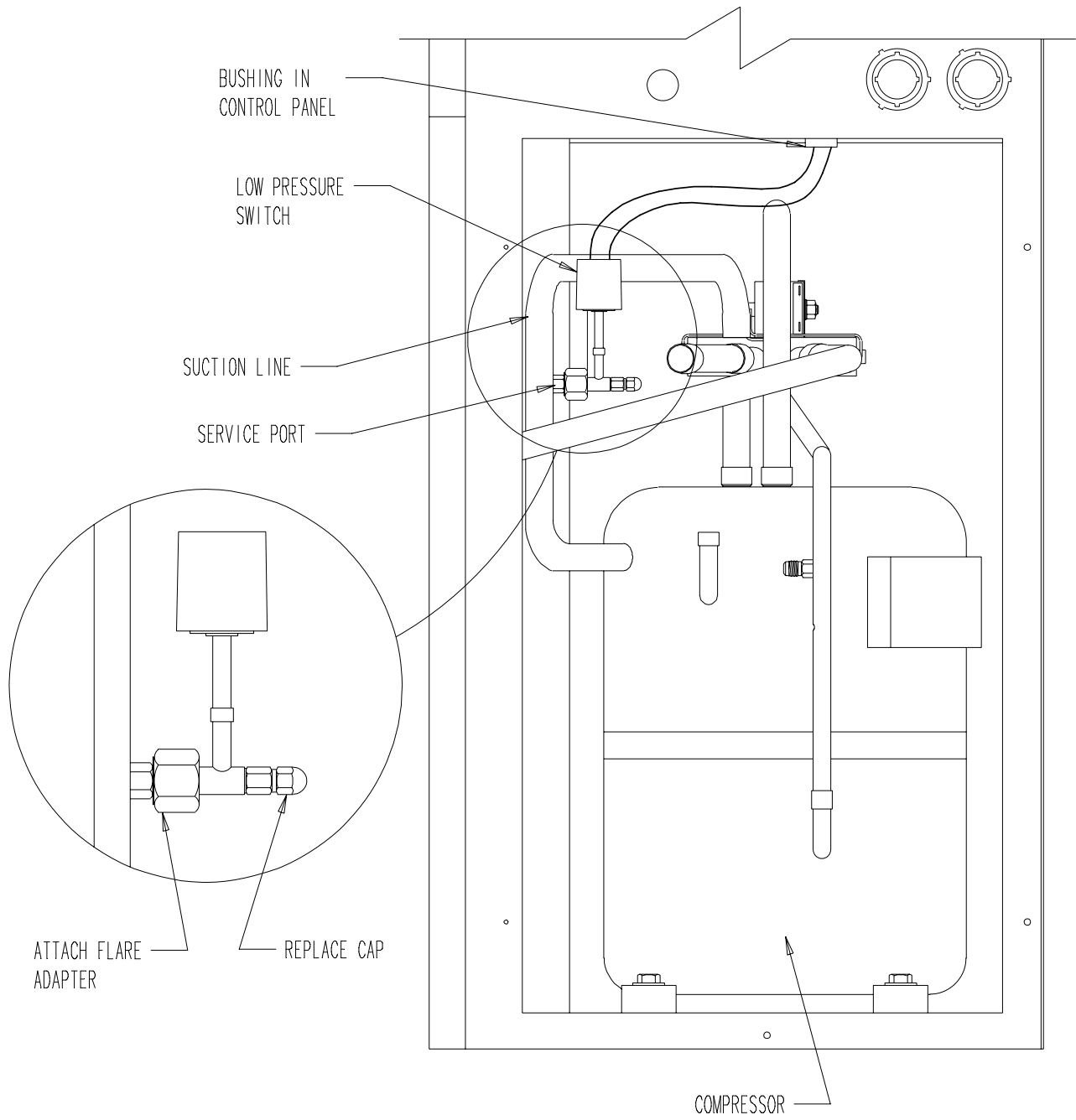

MIS-1392