

---

# SUPPLEMENTAL INSTRUCTIONS

---

## Plenum Box

### Models:

QPB42-V	QPBS42-V	QPBS48-V
QPB42-X	QPBS42-V-8	QPBS48-X
QPB42-1	QPBS42-X	QPBS48-X-8
QPB42-4	QPBS42-X-8	QPBS48-4
QPB48-V	QPBS42-1	QPBS48-4-8
QPB48-X	QPBS42-4	
QPB48-4	QPBS42-4-8	

---

### Installation

The plenum box is designed for use with the Q-TEC™ Series heat pumps. It is for use in free blow applications.

1. Remove the center screw from each top side of the unit (see Figure 1 on page 2).
2. Place plenum box on top of Q-TEC unit with the open side down and the grille facing the front of the unit.
3. Make sure that the bottom offsets of the plenum box are inside the top of the Q-TEC unit flange as shown in Figure 1. The outside of the plenum box should be flush with the outside of the unit.
4. Re-install the center screw in each top side of the Q-TEC unit. These screws will go through the clearance holes on the plenum box and hold it in place.
5. Adjust louvers to obtain desired air distribution.



*Climate Control Solutions*

Bard Manufacturing Company, Inc.  
Bryan, Ohio 43506  
[www.bardhvac.com](http://www.bardhvac.com)

Manual: 7960-359J  
Supersedes: 7960-359I  
Date: 2-21-23

**Figure 1**

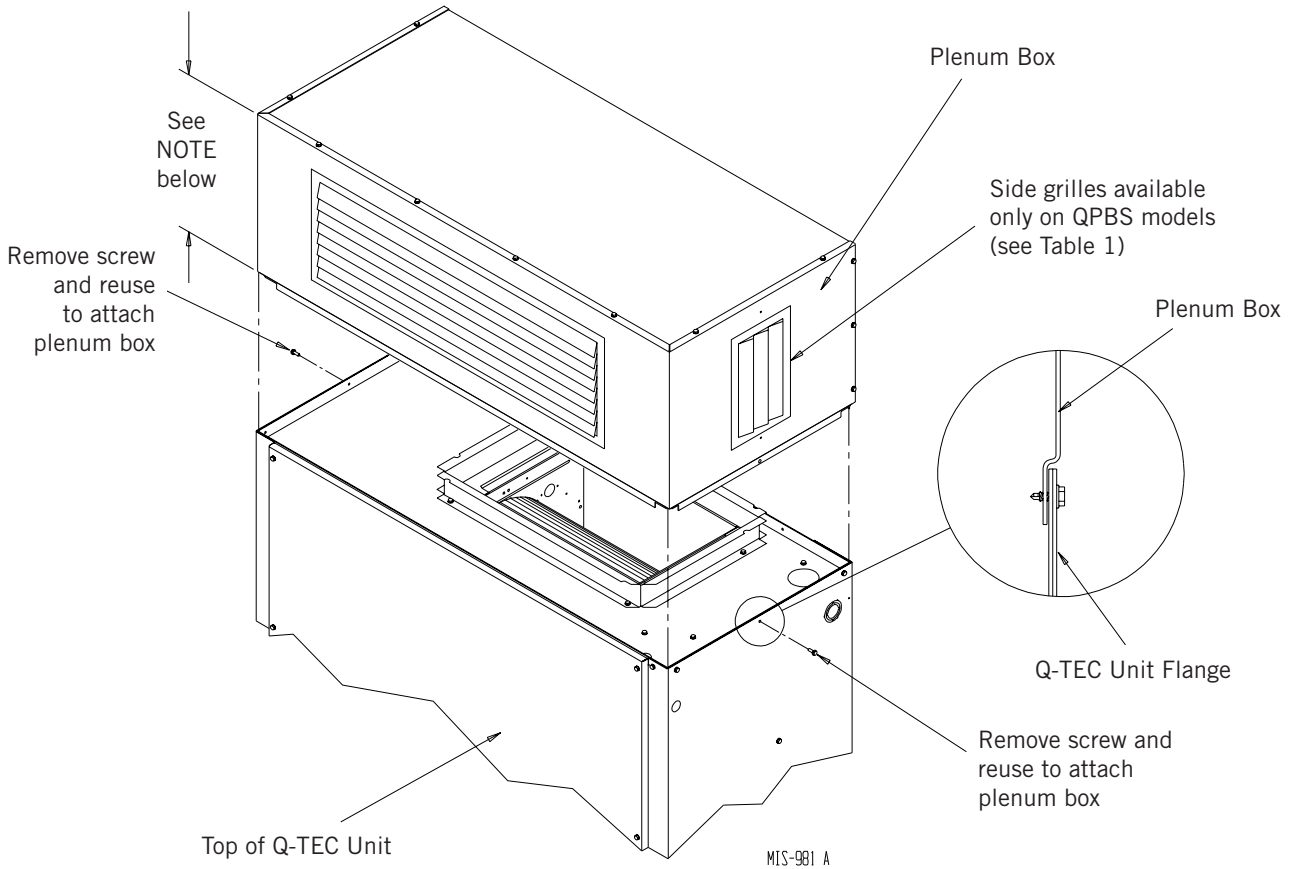

**NOTE:** Height of plenum box is 14" on all models except QPBS\*\*-\*-8 models which are 8" tall.

**Table 1**

Model Number	Front Grille Part Number	Side Grille Part Number
QPBS42-V	7051-035	7051-046
QPBS42-V-8	7051-073	7051-046
QPBS42-X	7051-035	7051-046
QPBS42-X-8	7051-073	7051-046
QPBS42-1	7051-035	7051-046
QPBS42-4	7051-035	7051-046
QPBS42-4-8	7051-073	7051-046
QPBS48-V	7051-045	7051-046
QPBS48-X	7051-045	7051-046
QPBS48-X-8	7051-078	7051-046
QPBS48-4	7051-045	7051-046
QPBS48-4-8	7051-078	7051-046
QPB42-V	7051-035	--
QPB42-X	7051-035	--
QPB42-1	7051-035	--
QPB42-4	7051-035	--
QPB48-V	7051-045	--
QPB48-X	7051-045	--
QPB48-4	7051-045	--