



Climate Control Solutions

Bard Manufacturing Company, Inc.  
Bryan, Ohio 43506

## **QSP3-4/QSP3-V /QSP3-X QSP5-4/QSP5-V/QSP5-X**

# **INSTALLATION INSTRUCTIONS**

This installation instruction covers the installation of the Q/Tec Series Sound Plenum.

The QSP3 series fits cabinet sizes that are 42" wide and includes Bard QA/QH 24-42 Models and all QW/QC Models.

The QSP5 series fits cabinet sizes that are 48" wide and includes Bard QA/QH 48 & 60 Models.

The -4 code in the model number is for Buckeye Gray pre-paint finish. The -V code in the model number is for Vinyl finish. When matching to the unit, please specify according to the 12<sup>th</sup> digit in the unit model number. (There are 15 total digits in a unit model number.)

Once this Sound Plenum is installed, it will have no effect on the full and complete serviceability of the Q/Tec Series unit. Any and all work will be able to be performed without removal of the Sound Plenum.

1. Uncarton the assembly from its packaging and locate the accessory bag that contains additional fasteners required to install the assembly onto the unit front.
2. Use a T-25 torx drive to remove the screws from the unit front (as marked in Figure 1).
3. Locate the sidepiece with "UL" stamped into it. (Hint: it has a ½ hinge attached to it.) (See Figure 2, Number 1.) This panel will secure to the Upper Left of the unit front using two screws that were removed in Step #2.
4. Locate the sidepiece with "LL" stamped into it. (Hint: it has a ½ hinge attached to it.) (See Figure 2, Number 2.) This panel will attach to the Lower Left of the unit front using one screw that was removed in Step #2.
5. Acquire two of the torx-headed screws provided in the accessory hardware kit and drive screws down from the Upper Left into the Lower Left (See Figure 2, Number 3).
6. Locate the side panel without any letters stamped into it (See Figure 2, Number 4). This panel will secure to the Upper Right of the unit front using two screws that were removed in Step #2.
7. Locate the side panel with the letter "L" stamped into it (See Figure 2, Number 5). This panel will attach to the Lower Right of the unit front using one screw that was removed in Step #2.
8. Acquire two of the torx-headed screws provided in the accessory hardware kit and drive screws down from the Upper Right into the Lower Right (See Figure 2, Number 7).
9. Locate the Sheet-Metal Assembly Top (solid piece). Acquire four of the torx-headed screws provided in the accessory hardware kit (See Figure 2, Number 7). Use the screws to attach the top – driving the (4) screws in from the Upper Sides to secure into place. (Hint: edge with single bend goes towards the unit.)
10. Locate the Sheet-Metal Assembly Bottom. Acquire four of the torx-headed screws provided in the accessory hardware kit (See Figure 2, Number 8). Use the screws to attach the bottom – driving the (4) screws in from the Lower Sides to secure into place. (Hint: edge with single bend goes towards the unit.)
11. Locate two self-drilling screws (hex-headed) provided in the accessory hardware kit. Making sure the sides are in good alignment – drive the screws into the unit front through the Lower Left and Lower Right sides (See Figure 2, Numbers 10 & 11) using a drill with the appropriate driver.
12. Locate the Upper Door. (Hint: Door has single latch and offset bend in it.) (See Figure 2, Number 11.) Hang door on the hinge-halves of the Upper Left Side.
13. Locate the Lower Door. (Hint: Door has two latches.) (See Figure 2, Number 12.) Hang door on the hinge-halves of the Lower Left Side.
14. Remove three torx-headed screws from accessory hardware kit (See Figure 2, Number 13). Drive screws downward from Upper Door into the Lower Door to secure the two pieces together.
15. Swing the doors closed and clasp latches shut. The latches are pre-adjusted at the factory, but should be evaluated for any required final adjustment.

FIGURE 1

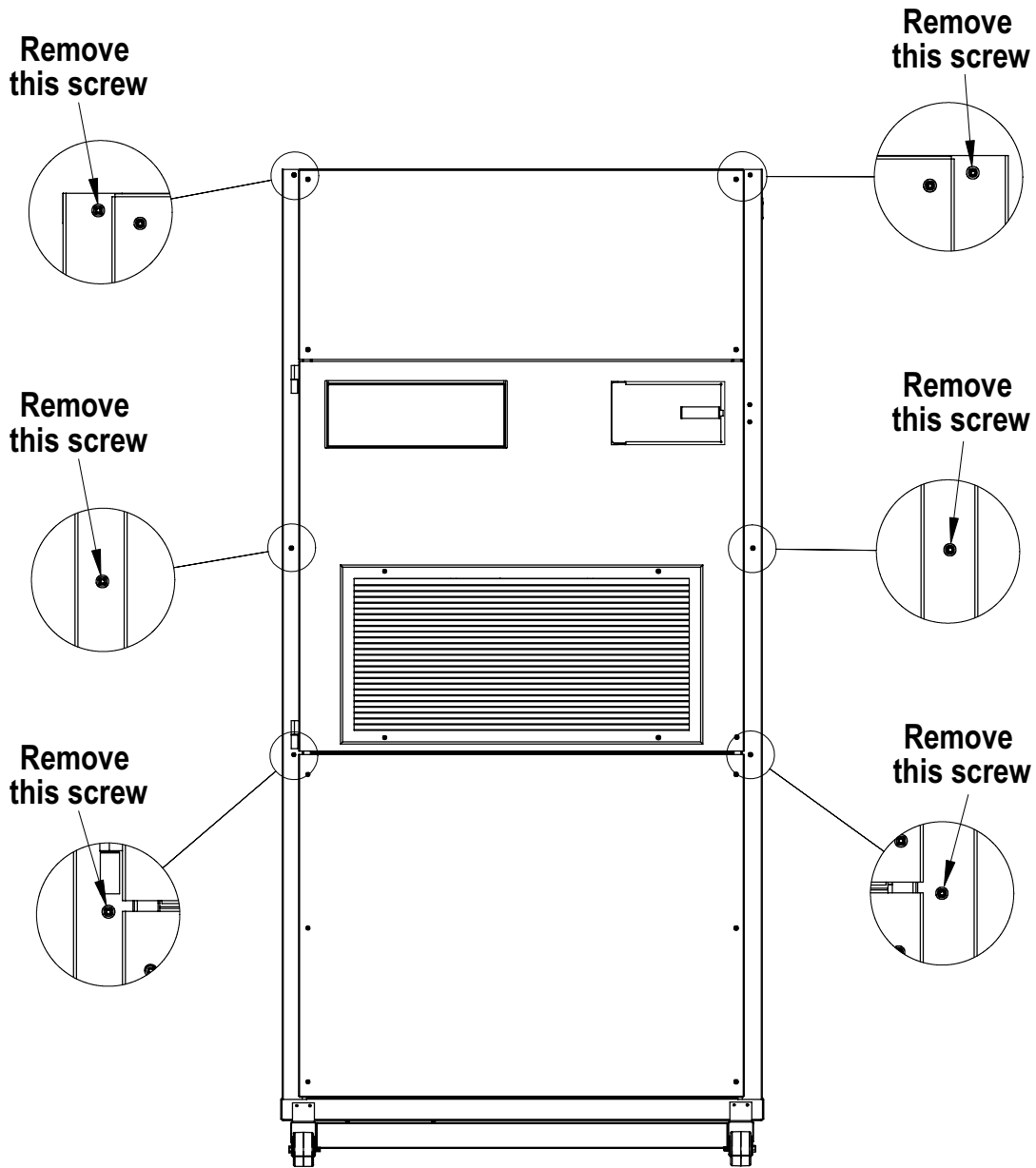

MIS-1982

FIGURE 2

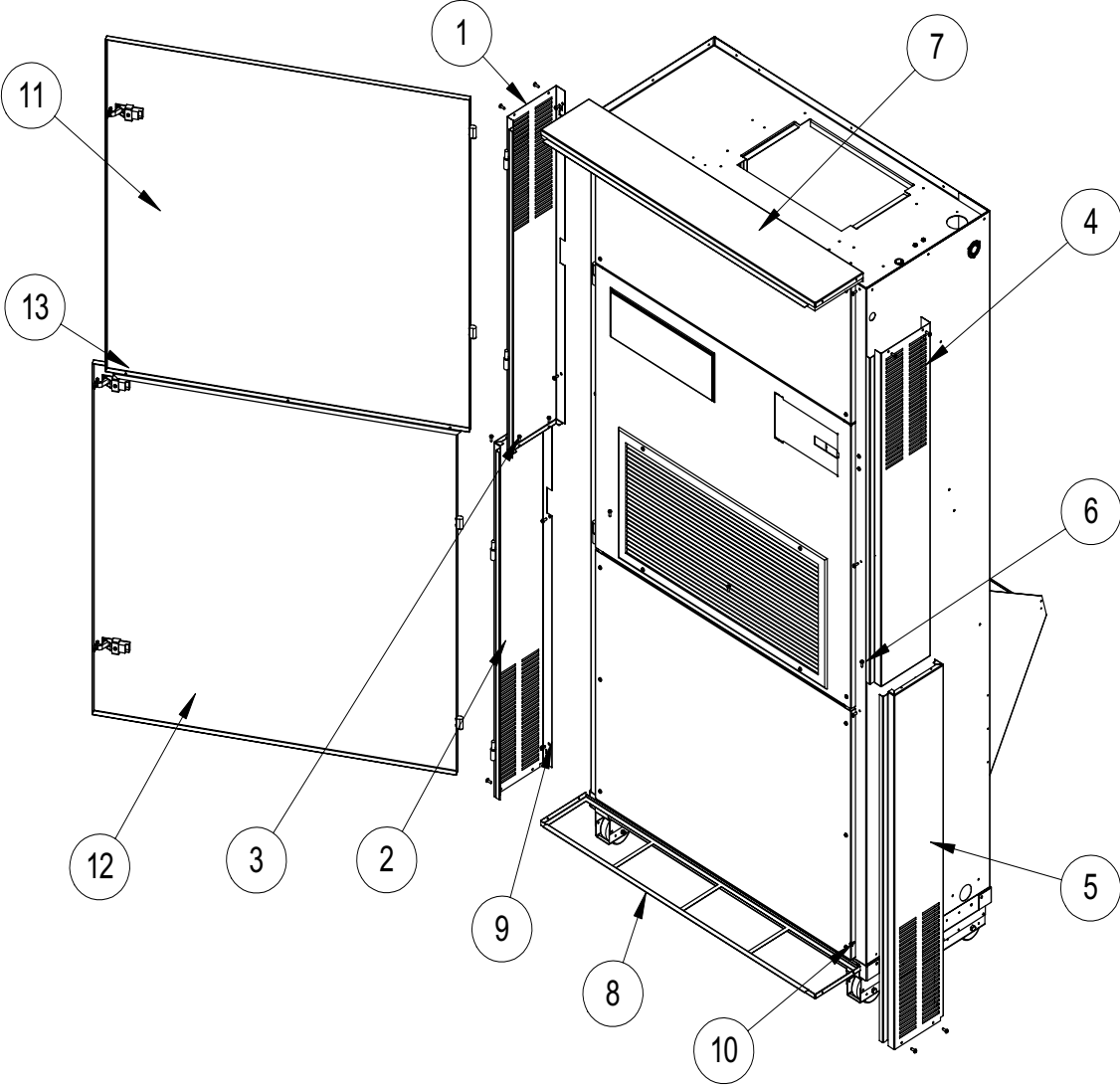

MIS-1983A