



Climate Control Solutions  
Bard Manufacturing Company, Inc.  
Bryan, Ohio 43506

## INSTALLATION INSTRUCTIONS

### CMH-18 Low Ambient 460V Fan Cycle Control

#### DESCRIPTION

The CMH-18 is a field installable low ambient fan cycling control for 460V motors. The CMH-18 460V head pressure control helps maintain the correct condensing temperature/pressure, which results in a constant head pressure. By adjusting the condenser fan speed, the CMH-18 controls the airflow through the condenser. A single desired temperature/pressure set point adjustment will result in precise condensing temperatures and stable head pressures. The CMH-18 consists of:

- |                                       |          |                            |          |
|---------------------------------------|----------|----------------------------|----------|
| • Fan speed control box               | 902-1294 | • 3/4" self-tapping screw  | 1012-087 |
| • Flat "Y" terminal splitter (Qty. 2) | 5081-009 | • Nylon wire ties (Qty. 6) | 7950-004 |
| • Tee adapter                         | 5810-006 | • CMH-18 unit I.D. label   | 8612-028 |

#### INSTALLATION INSTRUCTIONS FOR 460V CH SERIES

Disconnect all power to the unit. Remove control panel inner and outer covers, and both right and left side condenser inlet grilles. The circled numbers in this Manual's figures correspond to the installation instructions below. Dash lines indicate that a wire has been disconnected and discarded.

- Step 1. Mount fan speed control box as shown in Figure 2. To mount control box, you must first remove the two bolts holding the 460V transformer. Reinsert the two bolts with the flange of the control box under them as shown in Figure 2, Note 1. Using the 3/4" self-tapping screw, screw down the top flange of the control box to the back of the unit (Note 2).
- Step 2. Attach the pressure transducer and flare tee to the liquid line; then, install the service cap on the end of the service tee as per Figure 3. Check for leaks. Attach the plug from the control box installed in Step 1 above to the pressure switch.
- Step 3. Run all wires from low ambient control box (except the ones going to the pressure transducer) up through the bushing in the bottom of the unit control box as shown in Figure 1. Remove and discard the black wire running from the T2 terminal of the compressor contactor to the "3" terminal of the O.D. fan control relay (Note 1). Run the blue wire to the "B" terminal of the defrost control board (Note 2). Run the black/white wire to the "3" terminal of the O.D. fan control relay (Note 3). Run the black/red wire to the T2 terminal of the compressor contactor (Note 4). Run the two black wires with the shared terminal to the right 24V terminal of compressor control board and attach using the "Y" terminal splitter supplied with this kit (Note 6). Run the red wire to the left terminal of the 24V terminal of the compressor controller and attach using the "Y" terminal splitter (Note 5). Run the yellow wire to the common terminal of the compressor capacitor (Note 7).
- Step 4. Secure wires running on the outdoor section of the unit using the supplied nylon wire ties as shown in Figure 2 (Note 3). Be sure that there is no way that the wires can come in contact with the fan blade or any sharp edges.
- Step 5. Check wiring and control knob settings. See Figures 1 & 4.
- Step 6. Apply "this unit equipped with CMH-18 control module" label to the inside of the control panel cover above the wiring diagrams.
- Step 7. Replace all panels, grilles and covers. This completes the installation.
- Step 8. Check proper operation of the unit by energizing the compressor in cooling mode. The condenser fan motor should start and ramp up speed as system pressure increases.

# SEQUENCE OF OPERATION

Upon initiation, the CMH-18 will apply full voltage to the fan motor for the time period selected with the Hard Start knob. Hard start time is adjustable from 0.1 to 5 seconds. The hard start ensures correct rotation of the condenser fan, even in windy conditions. After a hard start, the control reads the temperature/pressure sensor and the fan speed is adjusted until the input temperature/pressure matches the set point.

The CMH-18 enables the user to set and adjust the pressure to be maintained by the control. The set point pressure is adjustable from 35 - 465 psig.

FIGURE 1

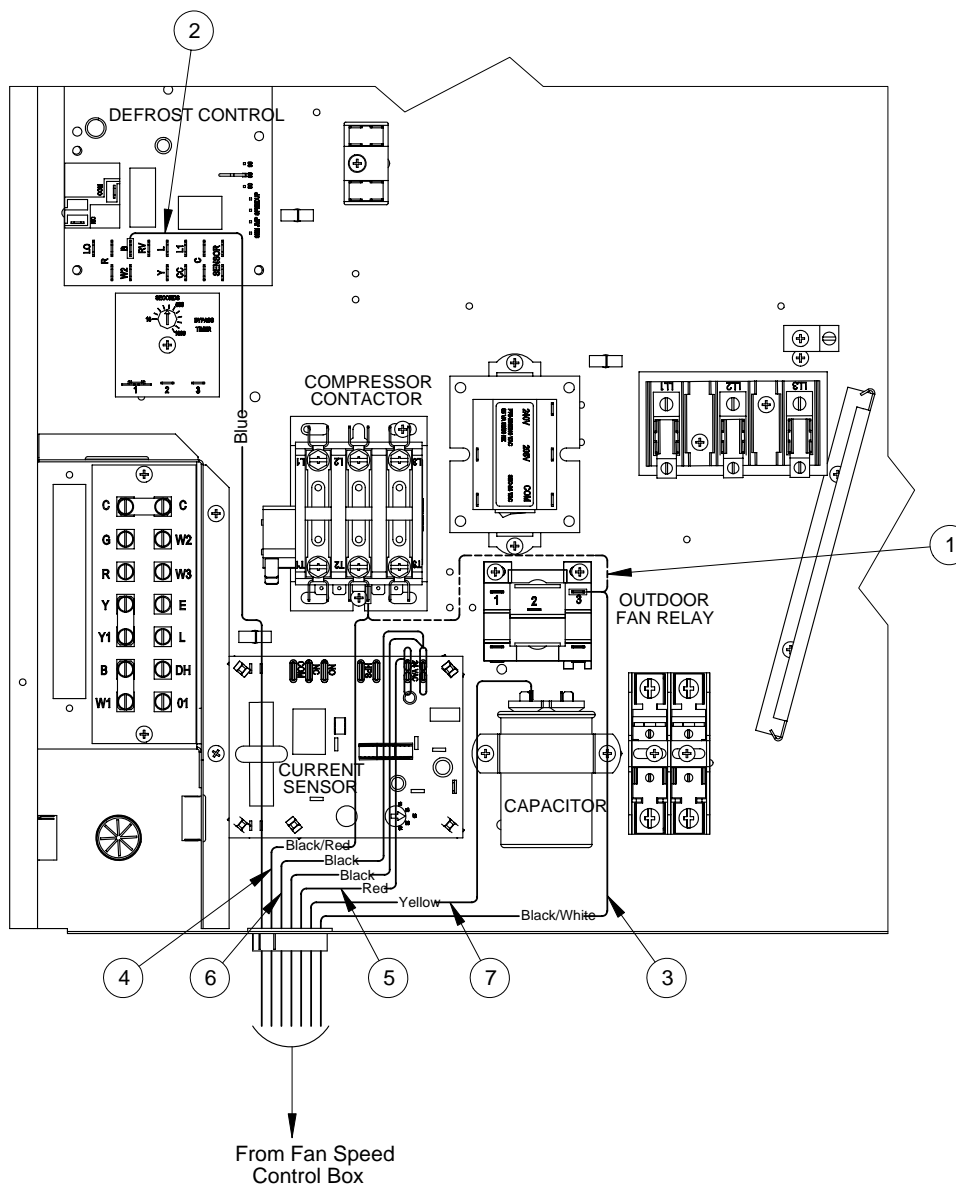

MIS-2320

FIGURE 2

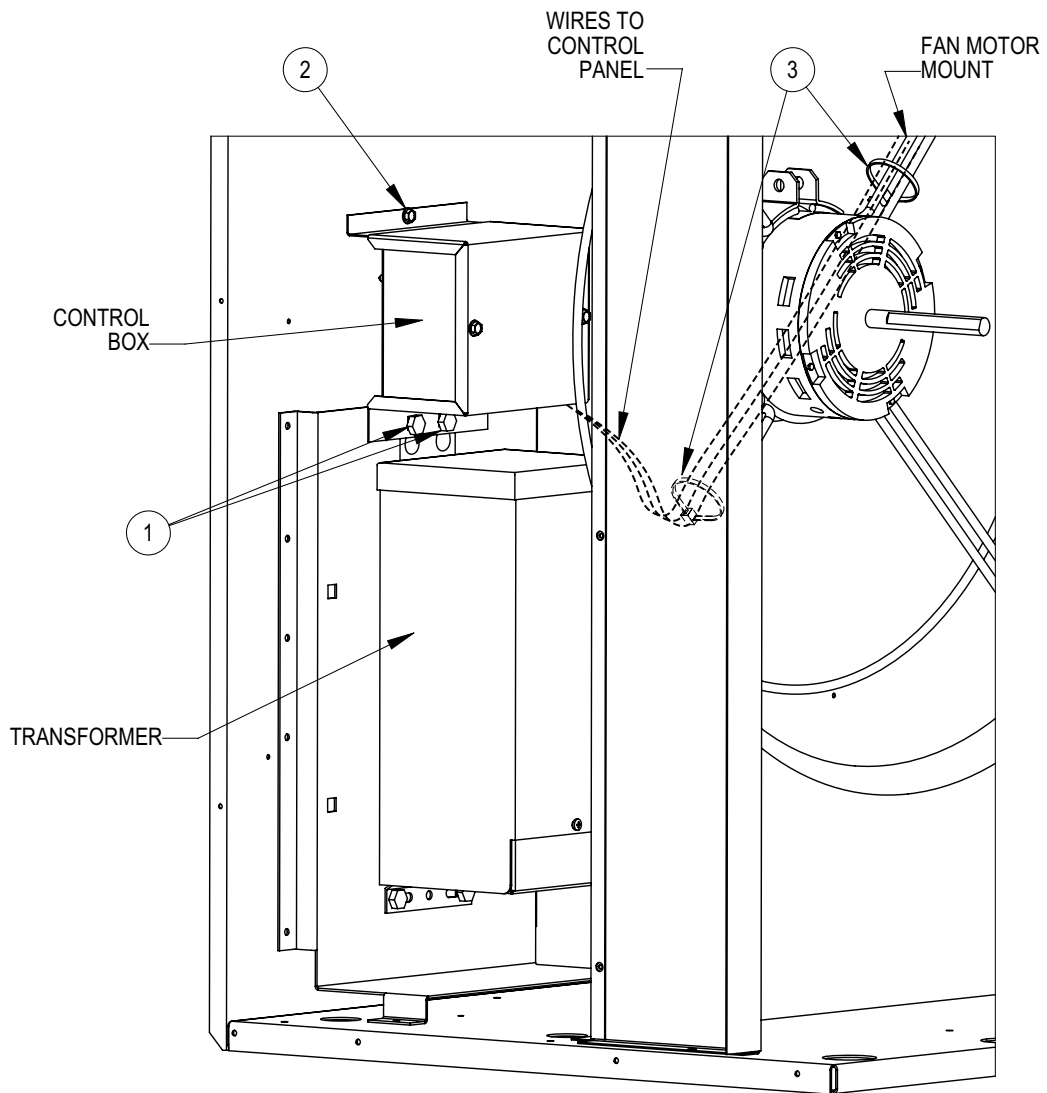

MIS-2321

**FIGURE 3**

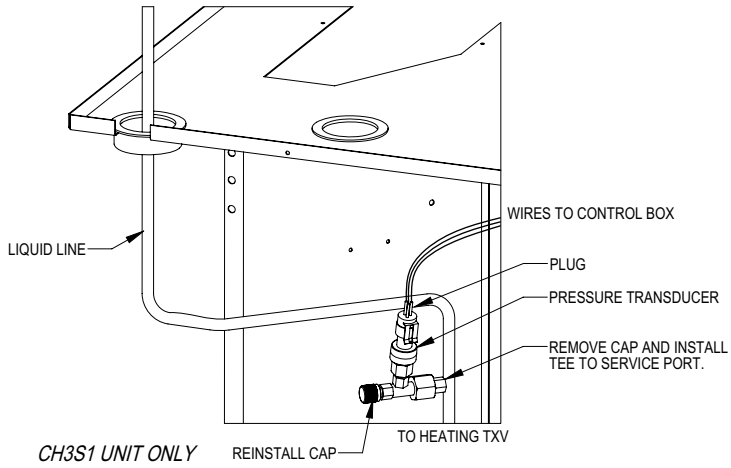
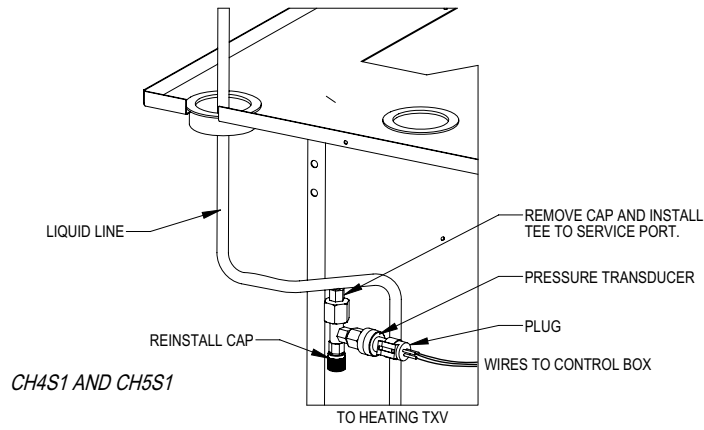

MIS-2322

**FIGURE 4**

Set "HARD START" to middle position

