INSTALLATION INSTRUCTIONS

CMA-30 DDC Sensors

For Use With W42 – 72AA Wall Mount Air Conditioners (A & B Electrical Versions Only)

The purpose of the CMA-30 kit is to allow the addition of sensors for connection to a DDC control system. These sensors include a dirty filter switch, a discharge air sensor, an airflow verification switch and a compressor current sensor.

The CMA-30 consists of field-installable sensors for use with DDC control systems. The CMA-30 includes:

- Installation instructions
- Airflow switch assembly
- Dirty filter switch assembly
- Compressor current sensor
- Discharge air sensor
- Low voltage terminal board
- Terminal board label

INSTALLATION

1. Disconnect all power to wall mount before installing sensors.
2. Remove inner and outer control panel covers. Remove electric heater access panel, service panel and blower access panel.
3. Install the airflow switch assembly (see Figure 1).
4. Route the wires into the control panel.
5. Install the filter switch assembly (see Figure 1).
6. Route the filter switch wires into the control panel.
7. Remove screw from the electric heater bracket (see Figure 2 on page 2).
8. Install the discharge air sensor.

Figure 1

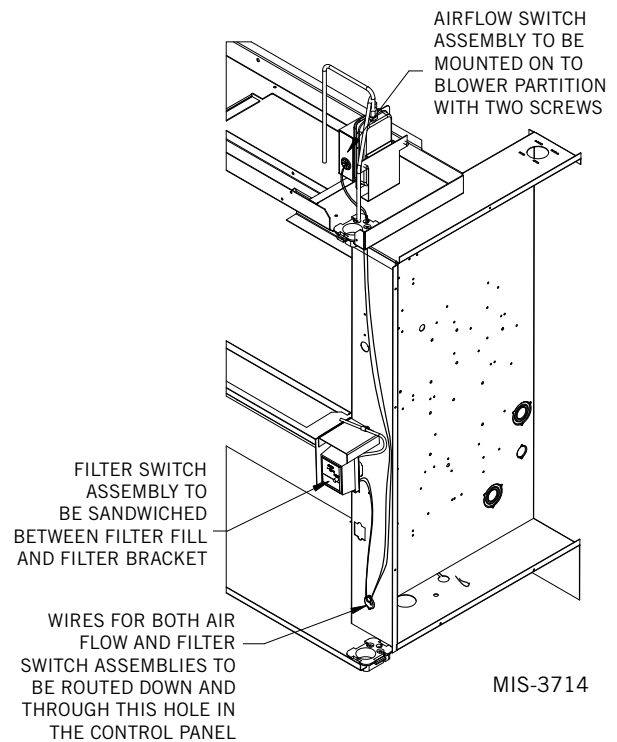

Bard Manufacturing Company, Inc.
Bryan, Ohio 43506
www.bardhvac.com

Manual: 7960-737
Supersedes: **NEW**
Date: 8-25-15

Figure 2

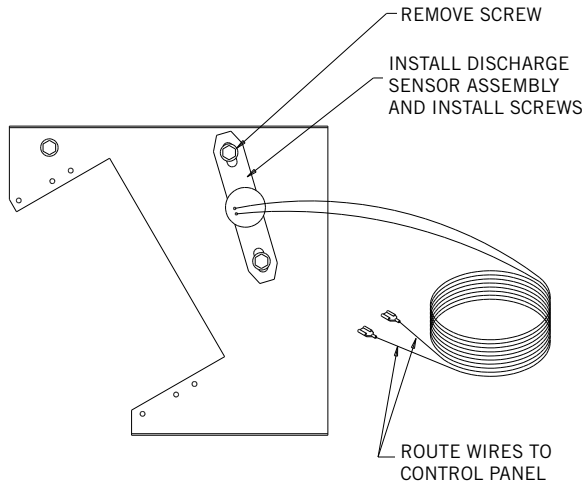

MIS-1141

9. Route the discharge air sensor wires into the control panel.
10. Remove the black wire from the compressor contactor (see Figure 3).
11. Route the wire through the hole in the current sensor and reconnect wire.
12. Mount the current sensor to the control panel.
13. Route the current sensor wire, airflow switch wire, filter switch wire and discharge air sensor wire into the low voltage box (see Figure 3).
14. Attach wires to the terminal board according to the wiring diagram (see Figures 3 and 4).
15. Carefully push wires into the low voltage box and install terminal board (see Figure 5).
16. Attach terminal board label to terminal board.

Figure 3

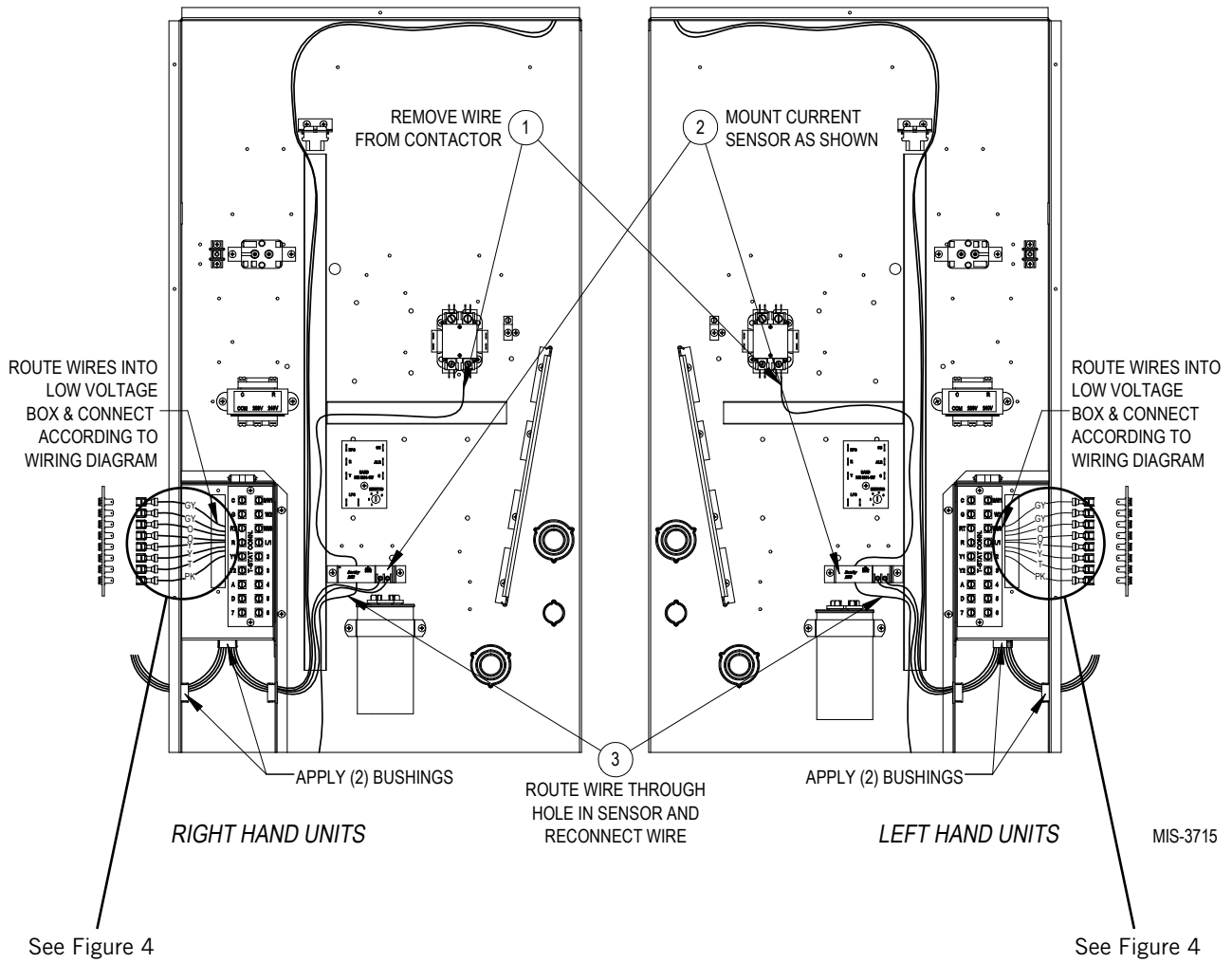

MIS-3715

Figure 4

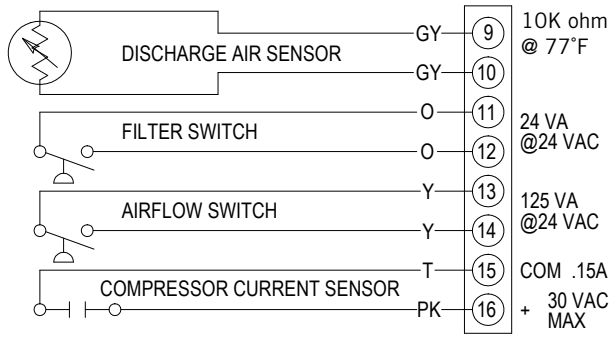

LEGEND	
GY	GRAY
O	ORANGE
Y	YELLOW
T	TAN
PK	PINK

MIS-3717

NOTE: USE CLASS ONE WIRING FOR CONNECTION TO THE LOW VOLTAGE TERMINAL BLOCK

17. Attach "CMA-30" label and wiring diagram to the inner control panel cover above the unit wiring diagrams.
18. Make low voltage connections from the DDC controller to the terminal board.
19. Install the blower access cover, control panel covers and heater access panel.
20. Apply power to unit
21. Turn the unit blower on.
22. Restrict the filter of the unit by 75%.
23. Adjust the filter switch until it trips.
24. Remove restriction and reset filter switch.
25. Install the service panel.

Figure 5

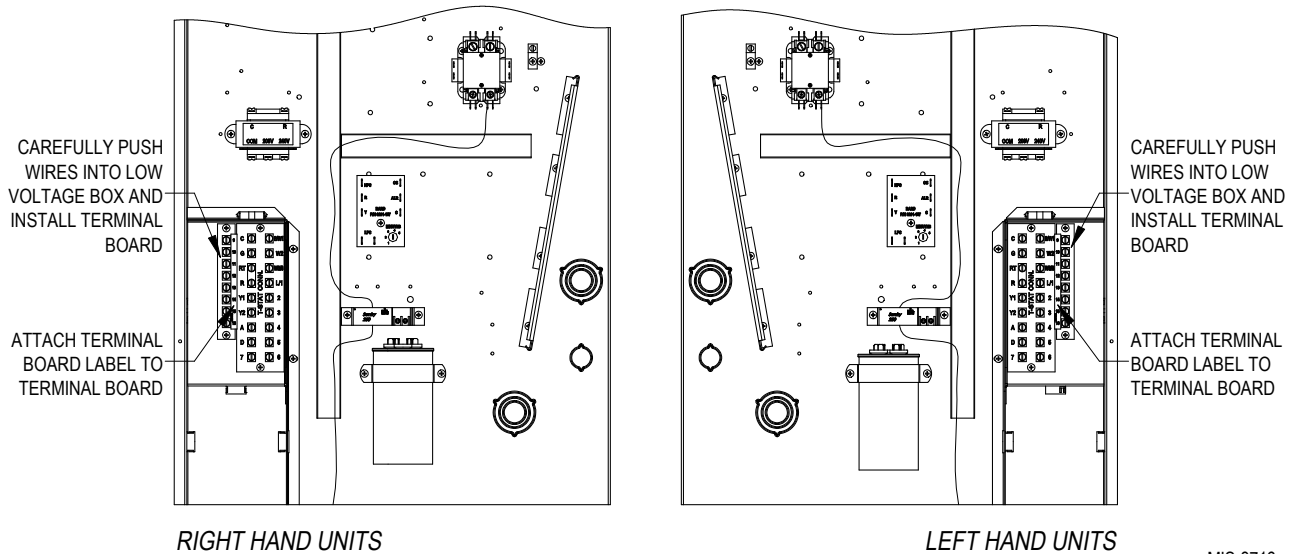

MIS-3716