SUPPLEMENTAL INSTRUCTIONS

CMH-35 Low Ambient Control Kit

The CMH-35 is a field-installable low ambient fan cycling control to be used with a Bard wall-mounted heat pump.

The CMH-35 kit is for use with Bard models W42HC, W48HC and W60HC wall-mount heat pumps.

The CMH-35 kit consists of:

- 7960-861B Supplemental Instructions
- 8406-105 Low Ambient Fan Cycling Switch
- 910-2111 Relay Assembly
- 910-2058 Outdoor Temp Switch Assembly
- 8408-048 Freeze Protect Thermostat
- 1012-065 Torx Head Screw (2)
- 1012-085 Hex Head Self-Tapping Screw (2)
- 7950-009 Cable Tie (4)
- 7961-312-0518 CMH-35 Unit I.D. Label

Field-supplied tools needed:

- Personal protection equipment, including gloves and safety glasses
- 5/16" nut driver
- 1/2" wrench (service port) and 9/16" wrench (LAC control)
- T20 Torx screwdriver

WARNING

Electrical shock hazard.

Disconnect the remote electric power supply or supplies before servicing.

Failure to do so can result in serious injury or death.

WARNING

Exposed moving parts.

Disconnect all electrical power before servicing.

Failure to do so can result in severe injury or amputation.

CAUTION

Sharp metallic edges.

Take care and wear appropriate protective devices to avoid accidental contact with sharp edges.

Failure to do so can result in personal injury.



Climate Control Solutions

Bard Manufacturing Company, Inc.
Bryan, Ohio 43506
www.bardhvac.com

Manual: 7960-861B
Supersedes: 7960-861A
Date: 5-29-20

Installation

1. Disconnect all power to the unit.
2. Remove outer and inner control panel covers, upper front panel, front grill and right-side condenser inlet grille.
3. Mount 910-2111 relay assembly to control panel as shown in Figure 1 on page 3. Use Torx head screws included with kit to attach relay to control panel.
4. Remove cover from gray cable ducts on control panel to allow wire harness from installed relay to route into it (see Figure 1).

NOTE: *The unit wiring diagram (included with unit literature assembly and also located on inner control panel cover) can be used to wire this kit. However, the following instructions listed here provide the necessary connections point-by-point.*

5. Locate black wire from the relay assembly and route through cable duct to defrost control logic board (see Figure 1). Before connecting this black wire to the NC fan relay contact on the defrost control logic board, remove wire that is currently connected there (on 230V models, it's the black outdoor fan motor lead; on 460V models, red/black wire) and connect that wire to Terminal 3 on the installed relay.
6. Locate black/white wire from relay assembly and route through cable duct to defrost control logic board. Connect black/white wire to C terminal. If the heat pump is a dehum unit, remove the black/white wire already connected to C terminal and stack it back onto the black/white wire from the relay assembly.
7. Locate blue wire from relay assembly and route through cable duct to defrost control logic board. Connect blue wire to B terminal. Remove blue wire already connected to B terminal and stack it back onto the blue wire from the relay assembly.
8. A service port is located on the refrigerant liquid line (same line as the filter drier and high pressure switch). This port is intended for the application of 8406-105 low ambient fan cycling switch (see Figure 2 on page 4). Remove the service cap from this service port and quickly thread the low ambient fan cycling switch onto this port. Once snug, use two wrenches to tighten the switch an additional 1/4 turn (one to hold the service port and one on the switch). Use soap bubbles to confirm the seal is completely tight on this connection.
9. Install outdoor temperature switch assembly to the fan shroud and route the wires to the control panel as shown in Figure 2. This switch defeats Balanced Climate airflow when the temperature falls below 50°F to help prevent evaporator freeze up. Refer to the unit installation manual for more information on Balanced Climate operation.
10. Install freeze protect thermostat to the evaporator coil as shown in Figure 3 on page 5. Route the wires down through the bushings in the blower partition and filter partition beside the filters and into the control panel.
11. Route the two black leads from the low ambient fan cycling switch up into the control panel with the other wires from this compartment, taking care to route and secure the wires. Use cable ties included with kit. Route the two black wires into the cable duct and then out towards the installed 910-2111 relay. Connect these two wires to Terminal 1 and Terminal 3 of the relay (see Figure 4 on page 6).
12. Find the purple and yellow/white wires not connected to anything that are tucked in the cable duct. Pull them out and connect them to each end of the outdoor temp switch wires. Refer to Figure 4 and the unit wiring diagram.
13. Locate the wire that is on the Y terminal of the defrost logic control board. This wire will either be yellow/white or yellow/black depending on the unit model. Remove from its original position and connect it to the freeze protect thermostat. Connect the other end of freeze protect thermostat the Y terminal on the defrost logic control board.
14. Recheck wiring by referring to unit wiring diagram.
15. Apply "This unit is equipped with CMH-35 control module" label to the inside of the inner control panel cover above the unit wiring diagram.
16. Replace all panels and covers. This completes the installation.
17. Turn on power to unit. Check for proper operation of the unit by referring to **Sequence of Operation**.

Sequence of Operation

Check for proper operation of the unit by energizing in cooling mode. The condenser fan motor should not run until the discharge pressure has exceeded 280 PSI. Should the liquid pressure fall below 180 PSI while running, the condenser fan motor will de-energize until the head pressure again builds to 280 PSI. Switch to heating mode. The condenser fan motor should run anytime the compressor is running regardless of the discharge pressure. Run unit through defrost cycle. The condenser fan motor should de-energize during the defrost cycle.

FIGURE 1
Unit Control Panel

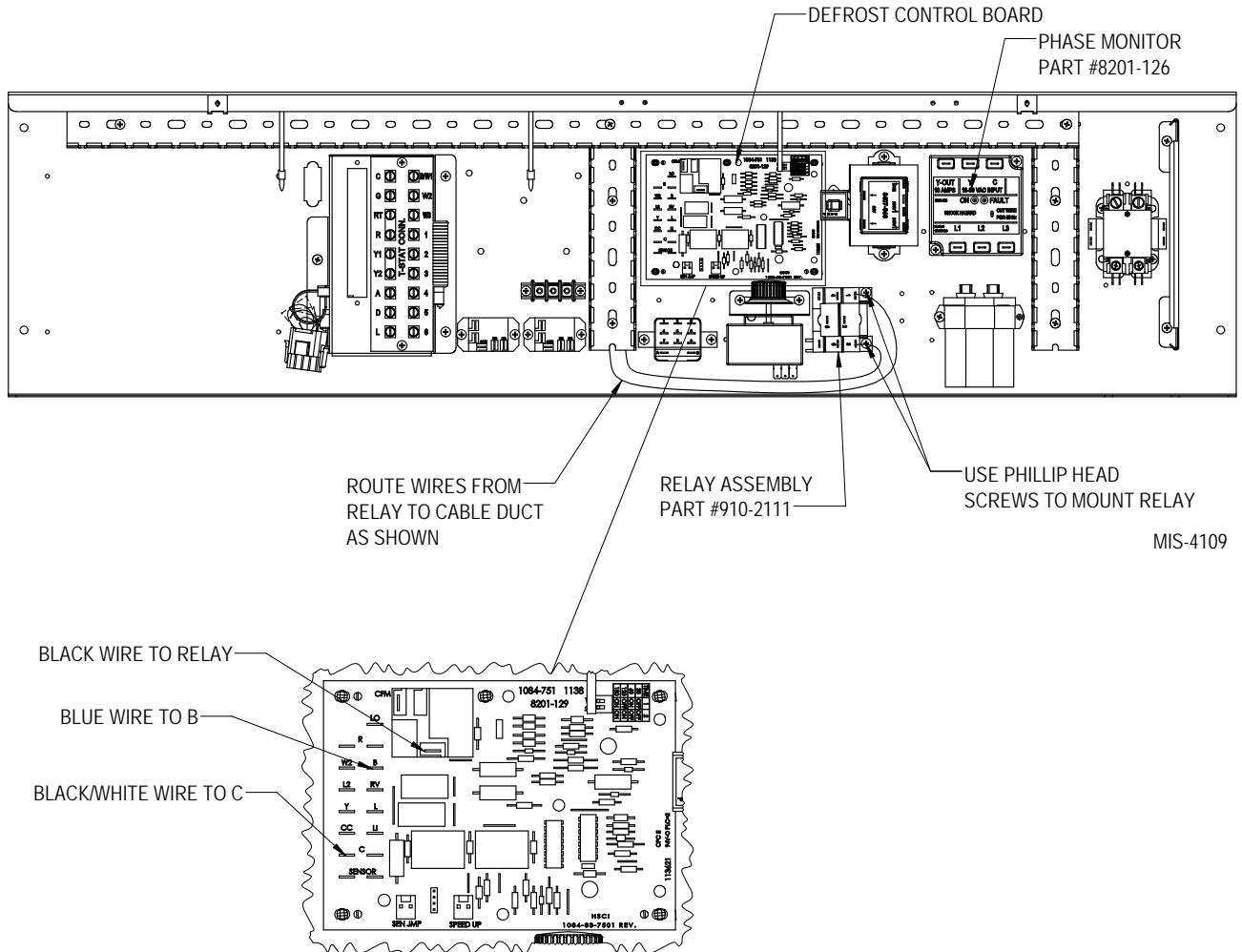
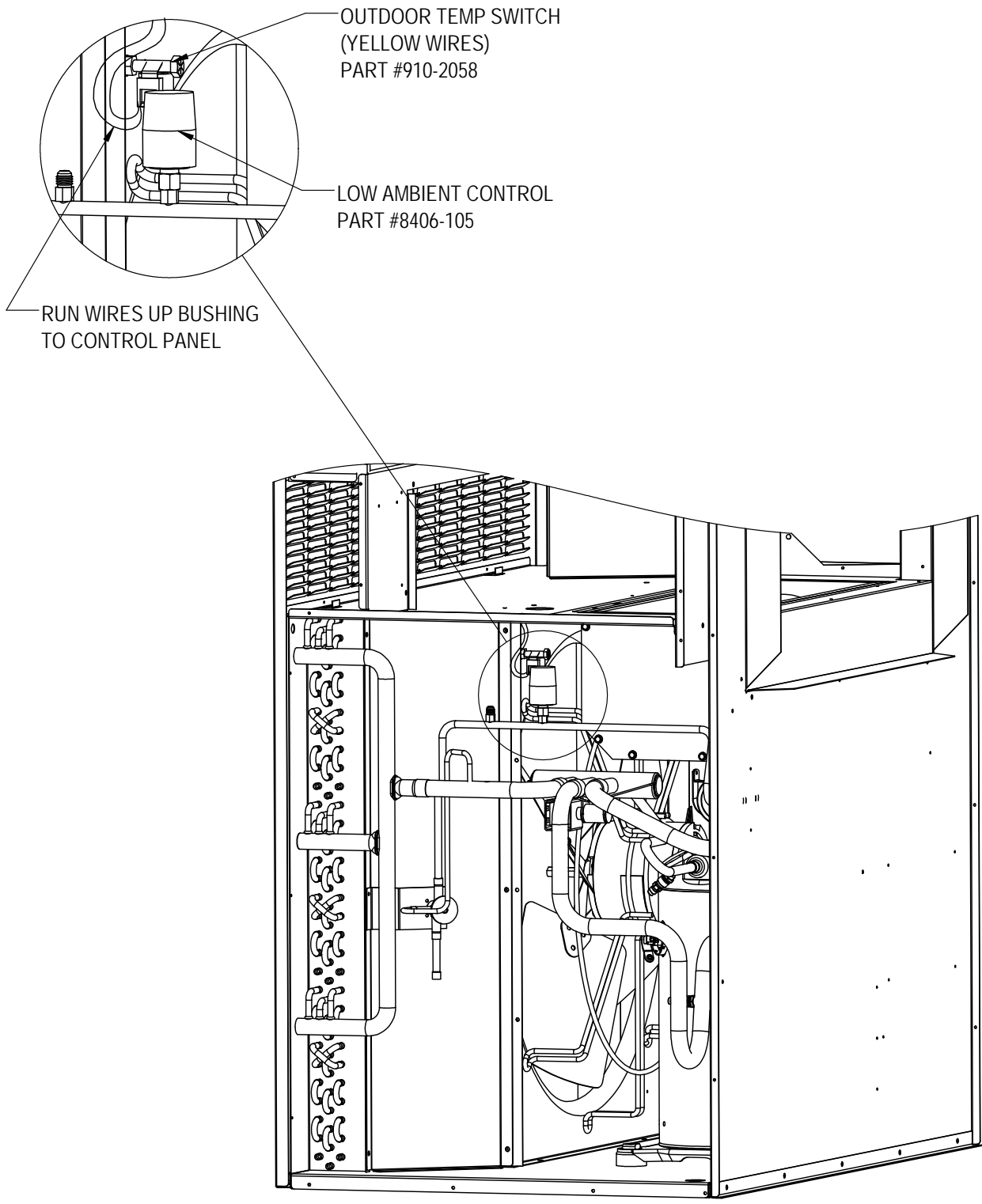
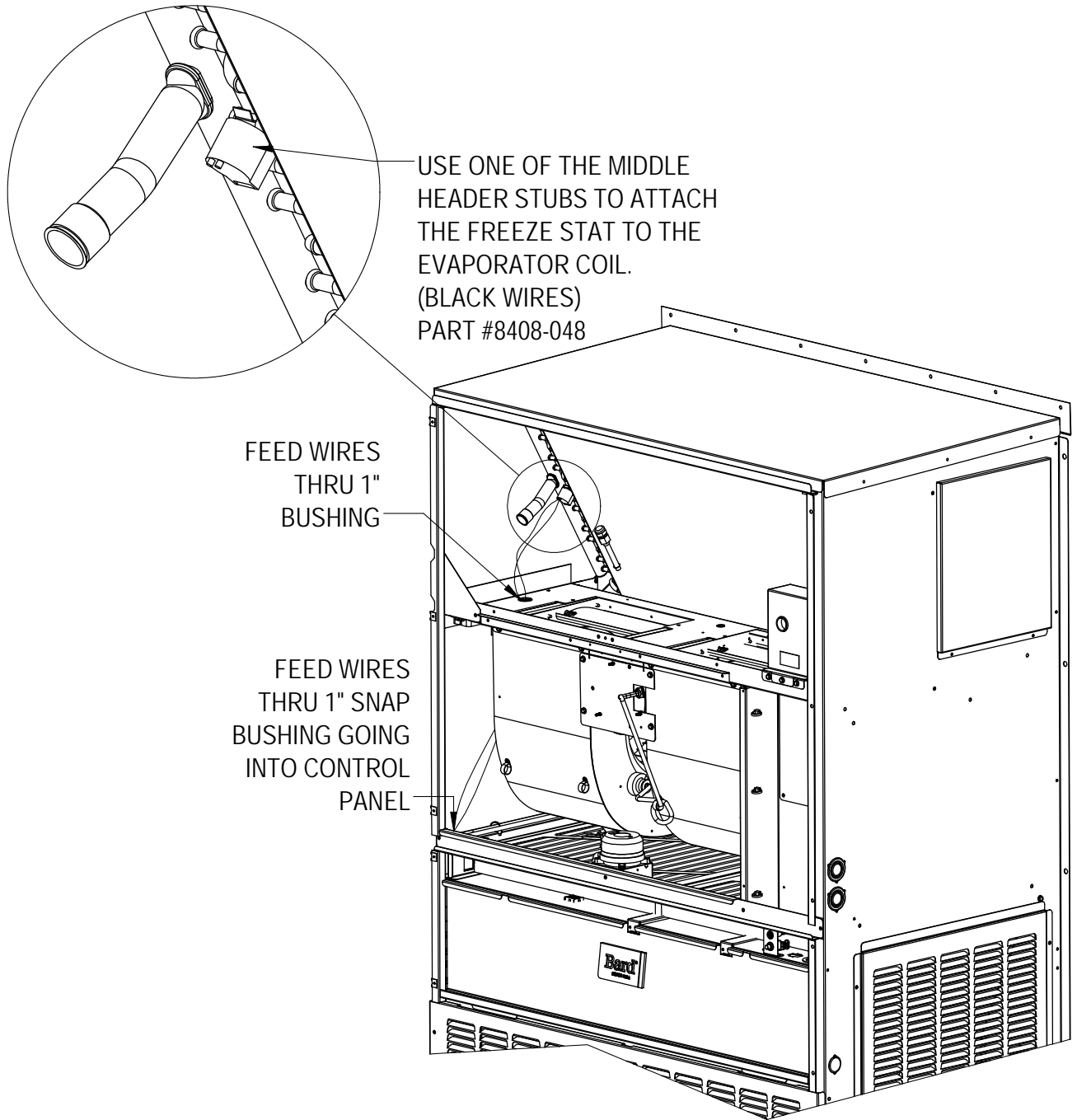

FIGURE 2



MIS-4110

FIGURE 3
Freeze Protect Thermostat Location and Wire Routing



MIS-4058

