

---

# SUPPLEMENTAL INSTRUCTIONS

---

## CMA-45 Low Ambient Fan Cycling Control

---

The CMA-45 is a field-installable low ambient fan cycling control kit. This low ambient control is only for use on R-410A refrigerant systems. The low ambient control pressure sensor is attached to the liquid line of the system, and monitors high side system pressure. Operation of the LAC occurs as outdoor temperatures drop below the 65°F to 50°F range. On/Off LAC operation cycles the condenser fan operation based on outdoor temperature.

The CMA-45 kit is for use with Bard W\*G4D dehumidification wall-mount air conditioners.

The CMA-45 kit consists of:

- 7960-865 Installation Instructions
- 8406-105 Low Ambient Fan Cycling Control
- 910-2058 Outdoor Temperature Switch Assembly
- 1012-066 3/4" Screw (1)
- 8607-017 Terminal Block
- 3018-1025 Wire
- 1012-086 1/2" Hex Screws (2)
- 7961-312-0520 CMA-45 Unit I.D. Label

Field-supplied tools needed:

- Personal protection equipment, including gloves and safety glasses
- 5/16" nut driver
- 1/2" wrench (service port) and 9/16" wrench (LAC control)
- Phillips head screwdriver
- Small flat head screwdriver for securing wire in terminal block

### **WARNING**

***Electrical shock hazard.***

***Disconnect the remote electric power supply or supplies before servicing.***

***Failure to do so can result in serious injury or death.***

### **WARNING**

***Exposed moving parts.***

***Disconnect all electrical power before servicing.***

***Failure to do so can result in severe injury or amputation.***

### **CAUTION**

***Sharp metallic edges.***

***Take care and wear appropriate protective devices to avoid accidental contact with sharp edges.***

***Failure to do so can result in personal injury.***



***Climate Control Solutions***

Bard Manufacturing Company, Inc.  
Bryan, Ohio 43506  
www.bardhvac.com

Manual: 7960-865A  
Supersedes: 7960-865  
Date: 5-7-20

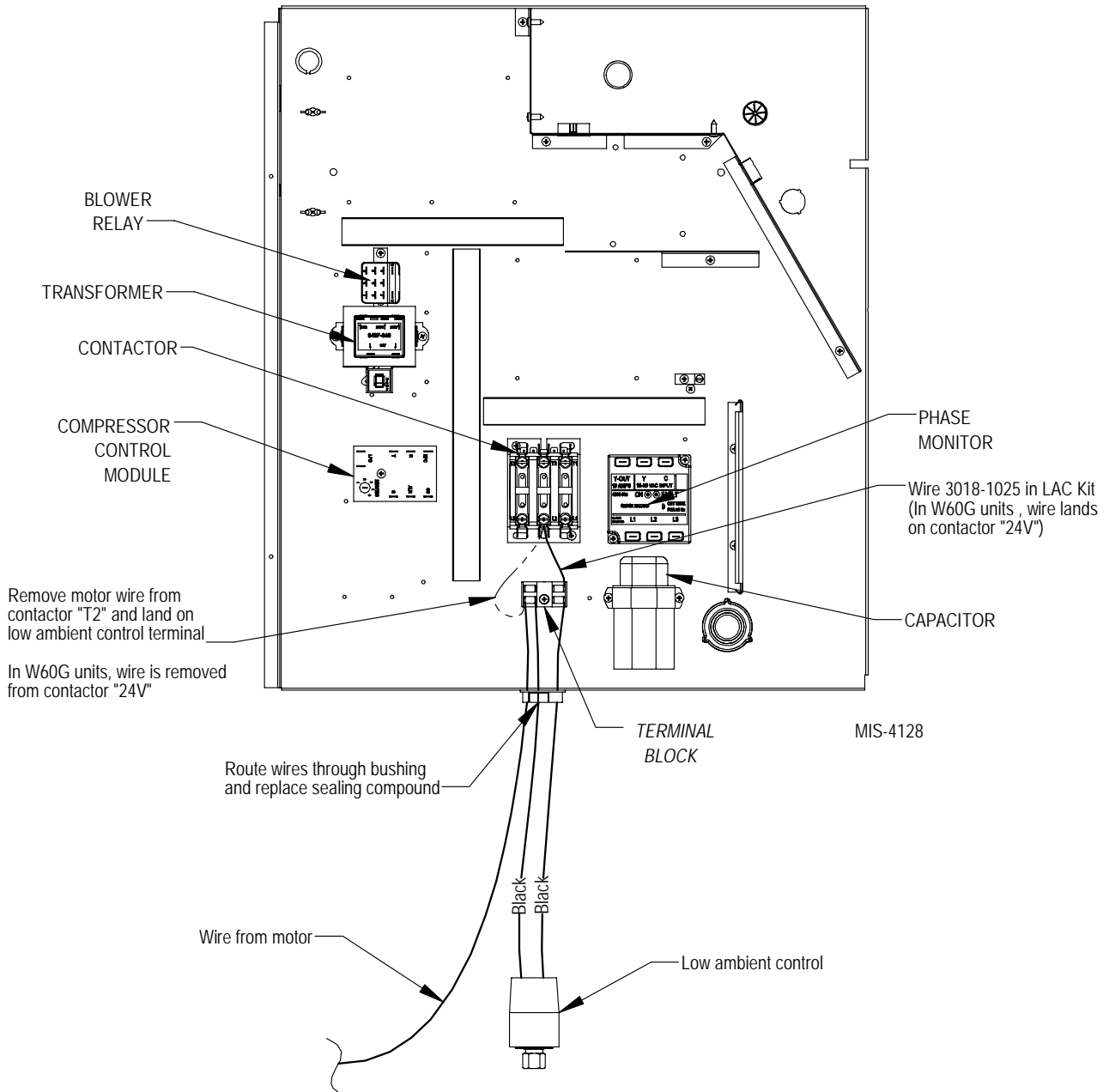
## Installation

1. Disconnect all power to the unit. Remove control panel inner and outer covers, upper front panel and right-side condenser inlet grille.
2. Mount supplied 8607-017 terminal block into control panel with supplied 1012-066 screw as shown in Figure 1.
3. Disconnect black high voltage outdoor motor lead from T2 on the compressor contactor (**NOTE: On W60G units, disconnect the yellow outdoor motor lead from 24V**) and reconnect to terminal block that was installed in Step 2 as shown in Figure 1 and Figure 3 (page 5).
4. Remove the service port cap from the liquid line. Install the low ambient control (LAC) on the liquid line by screwing it into the service port (see Figure 2 on page 4). Snug the connection with wrenches and check for leaks. Route low ambient control wires up through the bushing in the bottom of the control panel and connect one wire to each side of the terminal block as shown in Figure 1.
5. Connect the black wire supplied in the kit to the terminal block separate from the outdoor fan motor wire. Connect the other end to T2 on the compressor contactor. **NOTE: The W60 units will need to be wired to the 24V signal on the compressor contactor (refer to wiring diagram).** See Figure 1 or Figure 3.
6. Install outdoor temperature switch assembly to the fan shroud and route the wires through the bushing in the bottom of the control panel as shown in Figure 2 (page 4). This switch defeats Balanced Climate airflow when the temperature falls below 50°F to help prevent evaporator freeze up. Refer to the unit installation manual for more information on Balanced Climate operation.
7. Find the purple and yellow wires not connected to anything that are tucked in the cable duct. Pull them out and connect them to each end of the outdoor temp switch wires. Refer to Figure 3 or the unit wiring diagram.
8. Verify wiring by referring to unit wiring diagram.
9. Apply "This unit equipped with CMA-45 control module" label to the inside of the inner control panel cover above the wiring diagram.
10. Replace all panels and covers. This completes the installation.
11. Turn on power to unit. Check for proper operation of the unit by referring to **Sequence of Operation**.

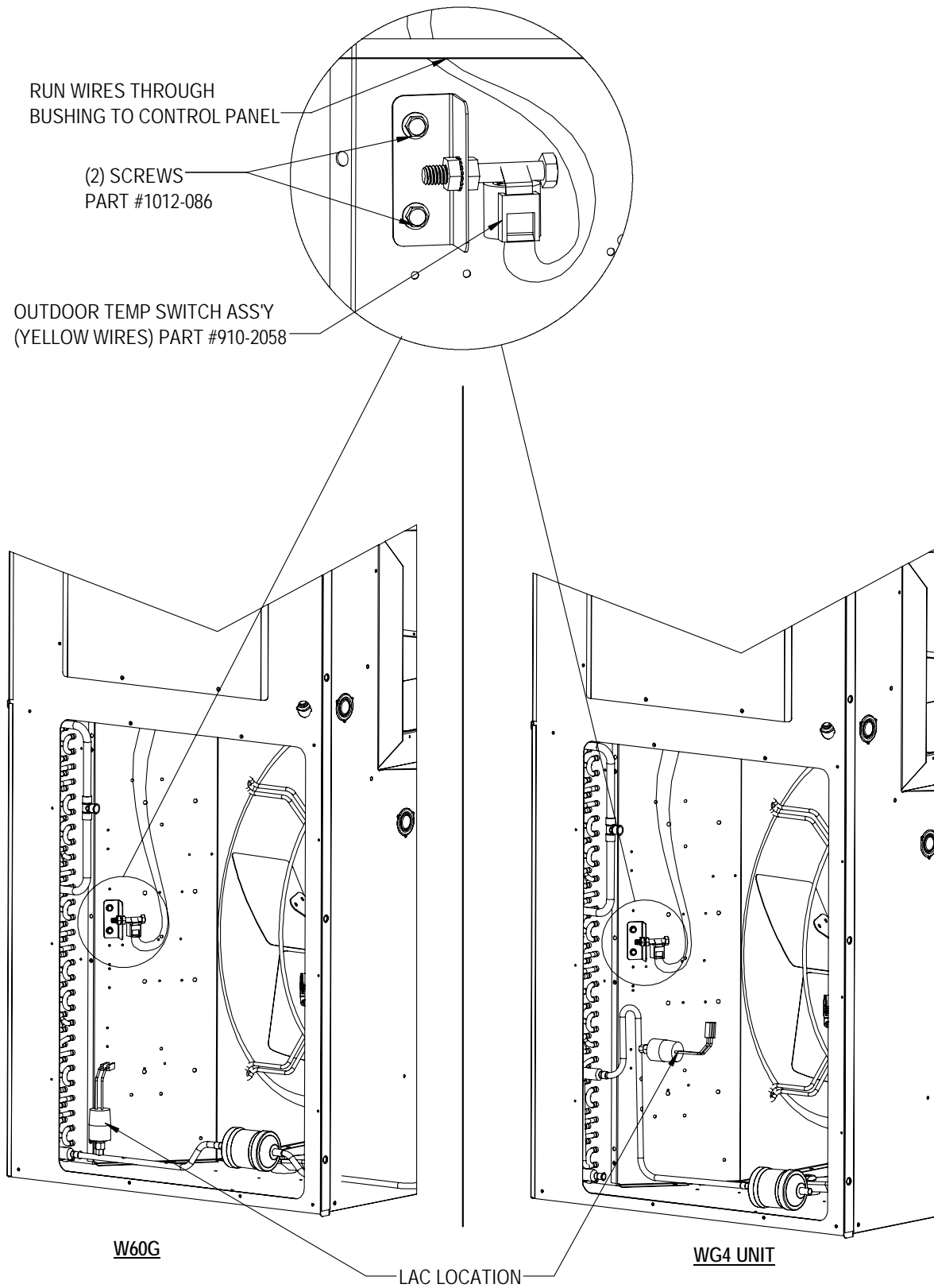
## Sequence of Operation

Energize the unit in cooling mode (first or second stage). The compressor should start (except when equipped with economizer and enthalpy control is energizing "free cooling" mode. Energizing Y2 will override the enthalpy control, allowing the mechanical cooling to operate). Run the unit for at least 5 minutes. The condenser fan motor should not run until the liquid pressure has reached 280 PSI. Should the liquid pressure fall below 180 PSI while running, the condenser fan motor will de-energize until the head pressure builds to 280 PSI.

**FIGURE 1**  
**Control Panel**

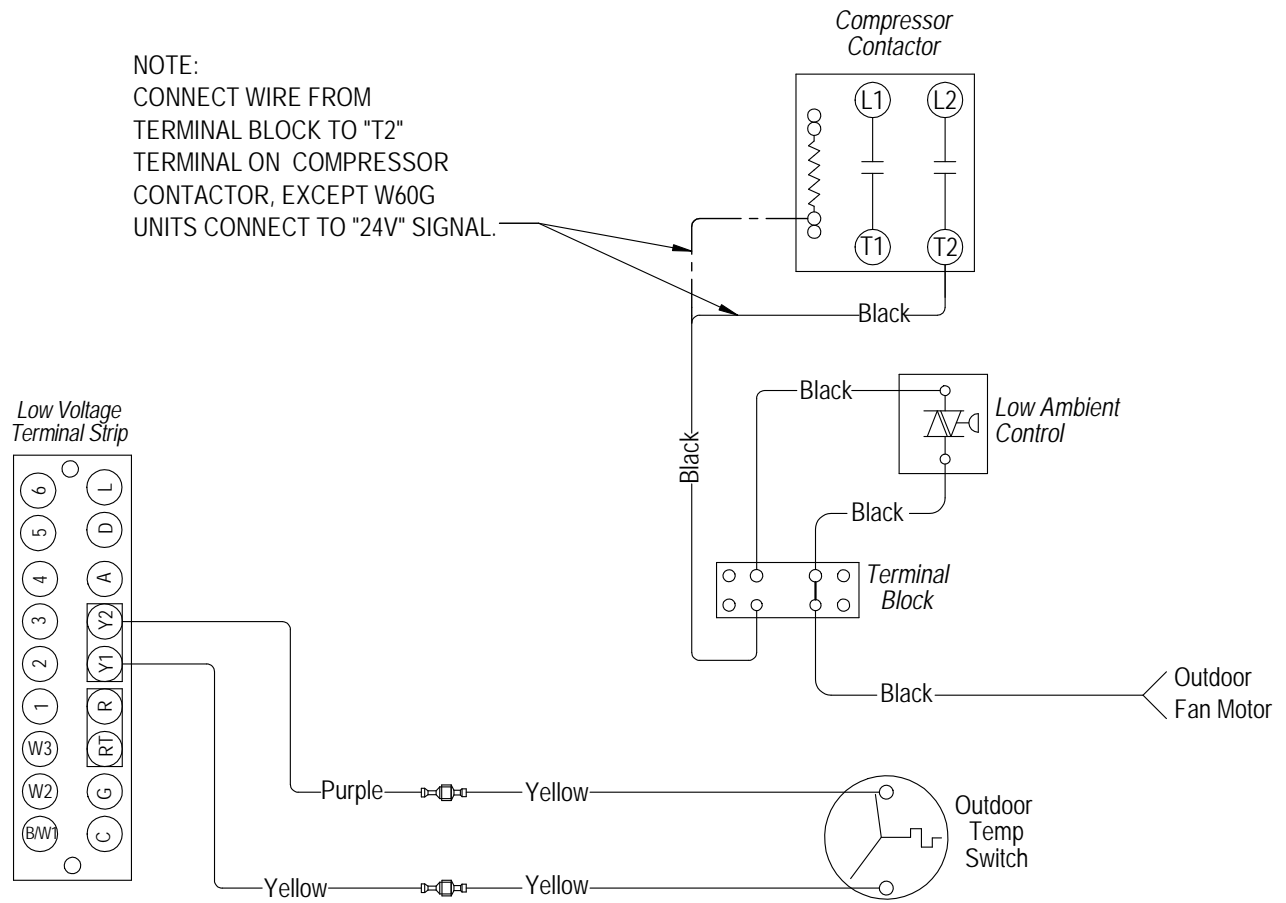


**FIGURE 2**  
**LAC and Outdoor Temperature Switch**



MIS-4127

**FIGURE 3**



MIS-4125 A