

CARBON DIOXIDE TRANSMITTER

Bard Part #8403-067 (Dwyer® CDT-2W40-LCD-RLY)

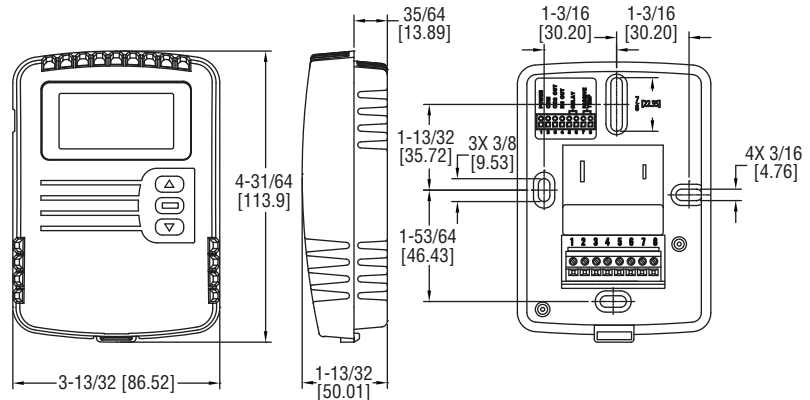

Series CDT Carbon Dioxide Transmitters accurately monitor the CO₂ concentration in schools, office buildings, and other indoor environments to help achieve LEED® certification. For increased sensor life, a single-beam dual-wavelength non-dispersive infrared (NDIR) sensor is used to automatically correct the measurement in both occupied and unoccupied buildings against aging effects. The single-beam dual-wavelength sensor technology provides the highest level of accuracy compared to Automatic Baseline Correction methods, which can unintentionally shift the calibration based on CO₂ levels and barometric pressure conditions. In order to achieve a higher level of accuracy, the Series CDT includes digital barometric pressure adjustment and the ability to field-calibrate the sensor.

Universal outputs allow users to select the transmitter output to be 4 to 20 mA, 0 to 5 VDC, or 0 to 10 VDC to work with virtually any building management controller. A relay output with user adjustable set points can be used to control ventilation systems is also included.

For visual indication, the 8403-067 includes an integral LCD display. Push buttons are standard on the transmitters for access to the menu structure, but the transmitter can be ordered without the buttons. To prevent tampering, the action of the buttons can be locked out using an internal jumper selection. Menu items that can be accessed include: engineering units, relay output set points, display configuration, transmitter output scaling, ambient barometric pressure and field calibration of the transmitter.

Single-beam dual-wavelength sensor advantages:

- Automatically corrects for aging effects in occupied and unoccupied buildings
 - Perfect for hospitals and manufacturing plants that are occupied 24 hours per day
- Measures actual unfiltered light intensity directly
 - Eliminates error from incorrect assumptions of gas concentration in theoretical logic assumption methods

SPECIFICATIONS

Range:

- CO₂: 0 to 2000
- Temperature: 32 to 122°F (0 to 50°C)
- RH: 0 to 100%

Accuracy: ±40 ppm + 3% of reading

Temperature Dependence: ±8 ppm / °C at 1100 ppm

Non-Linearity: 16 ppm.

Pressure Dependence: 0.13% of reading per mm of Hg.

Response Time: 2 minutes for 99% step change

Ambient Operating Temperature: 32 to 122°F (0 to 50°C)

Ambient Operating Humidity: 10 to 95% RH (non-condensing)

Power Requirements: 16 to 35 VDC / 19 to 28 VAC

Power Consumption: Average: 2 watts; Peak: 3.75 watts

Sensor: Single-beam, dual-wavelength NDIR

Output:

- Current: 4 to 20 mA (max 500 Ω)
- Voltage: 0 to 5 VDC or 0 to 10 VDC (min 500 Ω)
- Relay: SPST NO 2A @ 30 VDC

Weight: 5.6 oz (158.8 g)

INSTALLATION

WARNING Disconnect power supply before installation to prevent electrical shock and equipment damage.

Make sure all connections are in accordance with the job wiring diagram and in accordance with national and local electrical codes. Use copper conductors only.

CAUTION Use electrostatic discharge precautions (e.g., use of wrist straps) during installation and wiring to prevent equipment damage.

CAUTION Avoid locations where severe shock or vibration, excessive moisture or corrosive fumes are present.

CAUTION Do not exceed ratings of this device, permanent damage not covered by warranty may result.

NOTICE Upon powering the transmitter, the firmware version will flash on the display. A warm up period of 30 minutes is required for the transmitter to adjust to the current CO₂ concentration.

NOTICE Self calibration feature of the transmitter requires exposure to normal outdoor equivalent carbon dioxide level once every thirty days.

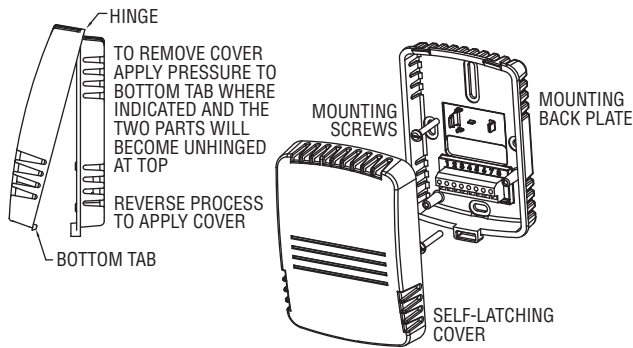

Figure 1: Removal Of Cover From Back Plate

MOUNTING

1. Push tab on bottom of cover and lift cover from back plate (See Figure 1).
2. Select the mounting location, away from diffusers, lights or any external influences.
3. Mount transmitter on a vertical surface to a standard electrical box using the two #6 M2C type screws provided.
4. Pull wires through sub base hole and make necessary connections.
5. Reattach cover to base plate.

WIRING

Use maximum 18 AWG wire for wiring to terminals. Refer to Figure 5 for wiring information.

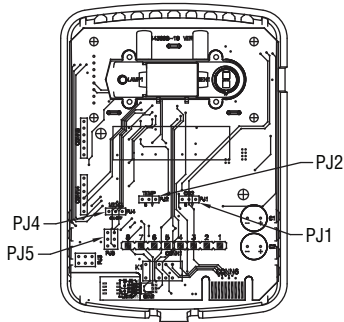

Figure 2: Diagram Of Circuit Board

Selection of Current and Voltage Outputs

Prior to wiring, verify that the current/voltage selection jumpers (PJ1, PJ2 and PJ5) are set to the desired output type. Refer to Figure 2 to locate the selection jumpers. See Figure 3 for diagram of the current/voltage selection jumper. For voltage output selection, the output can be 0 to 10 VDC, 0 to 5 VDC, 2 to 10 VDC or 1 to 5 VDC. See Figure 4 for the type of voltage output selection jumper (PJ5).

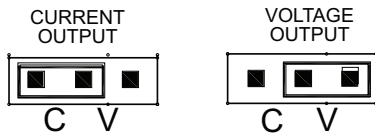

FIGURE 3: Current/Voltage Output Selection Jumper (PJ1 And PJ2)

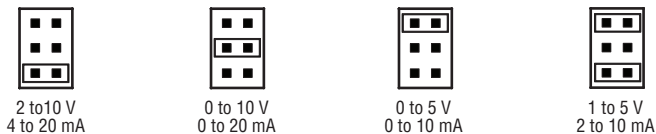

Figure 4: Output Range Selection Jumper (PJ5)

Current / Voltage Outputs

On the CDT, the transmitter may be wired for current or voltage output for carbon dioxide. The transmitter can be powered with either 16 to 35 VDC or 19 to 28 VAC. Wire the transmitter according to Figure 5.

NOTICE

Optional relay can be used as either a dry contact or low voltage switched circuit up to 2 A at 30 VDC.

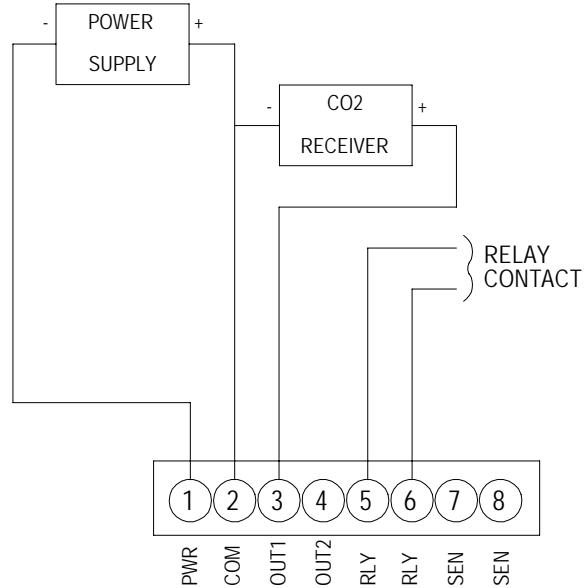

MIS-3189

Figure 5: Wiring

EDITING MENU PARAMETERS

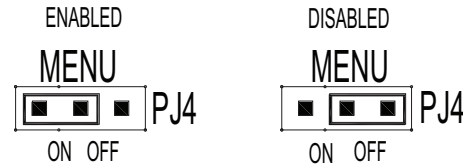

Figure 6: Menu Lockout Jumper

Before any adjustment can be made to the transmitter, the Menu Lockout Jumper (PJ4) must be set to the "On" position (See Figure 6).

ACCESSING MENU PARAMETERS

- Step 1: To enter the menu structure, press Δ and ∇ simultaneously for 5 seconds (display will show RON parameter).
- Step 2: Press Δ or ∇ to cycle between menu items.
- Step 3: Press \square to edit the value for the displayed menu item (SET will appear on display).
- Step 4: Press Δ or ∇ to adjust the value of the menu item.
- Step 5: Press \square to save the changes (SET will disappear).
- Step 6: Repeat Steps 2 through 5 for each of the parameters.
- Step 7: To exit the menu at any time, press and hold Δ and ∇ simultaneously for 5 seconds or wait 10 seconds without pushing any buttons.