



Q-TEC™ QWS Series High Efficiency Geothermal/Water Source Packaged Step-Capacity Heat Pump — R-410A

2 to 5 Ton **2-Stage Compressors**
Extended Range Operation: 25° to 110°F EWT

The Q-TEC Series self contained packaged water-to-air heat pump is designed to be installed inside a building structure against an exterior exposed wall when ventilation option is selected. When no ventilation option is used, the QWS Series units can be installed in any interior space accessible to water supply system and condensate drain.

Q-TEC's design provides "whisper" quiet operation with total comfort for the occupants at high efficiency levels and eliminates the need for roof-mounted equipment and outside condensing units and can meet your specific architectural requirements.

Q-TEC's "quiet technology" provides extremely low indoor sound levels by using special components and materials in the construction of the unit. By using special motors and sound insulation we have built a heat pump system that is significantly quieter than competitive product available today.

Q-TEC is suitable for both new construction and renovation projects for schools, modular buildings and light commercial buildings. A variety of ventilation options are designed to address your project's indoor air quality.

The Q-TEC Series unique design allows all maintenance and service to be performed inside the building to facilitate multi-story installations. Access to air filters and controls is accomplished through a hinged front panel for easy accessibility. All Q-TEC Series models are built on heavy duty permanent rollers for easy installation and removal.

Engineered Features

Step Capacity Compressor:

Copeland step capacity (2-stage) scroll compressors are designed for increased efficiency, quieter operation and improved reliability for longer life.

Reduced Sound Level:

Compressor sound cover and double isolation grommets reduce sound levels. Discharge muffler used on all models.

R-410A Refrigerant:

Designed with R-410A (HFC) non-ozone depleting refrigerant in compliance with the Montreal protocol and 2010 EPA requirements.

Liquid Line Filter Drier:

Standard on all models.

Phase Rotation Monitor:

Standard on all 3 phase scroll compressors. Protects against reverse rotation if power supply is not properly connected.

Indoor Blower System:

All models feature a variable speed (ECM) motor providing super high efficiency, low sound levels and soft start capabilities. The motor is self adjusting to provide the proper airflow rate at high static pressure for ducted installations without user adjustment or wiring changes. Dual blower and 30-second ramp up and ramp-down on motor used for quiet operation.

High Efficiency Coaxial Water Coil:

Fully insulated to minimize sweating. Copper or cupro-nickel coils available. Copper coils approved for Ground Loop and Closed Loop Boiler / Tower only.

Fluid Flow Switch:

Provided for coaxial coil to protect against loss of water flow.

Double O-Ring Water Connections (Optional):

Positive water-tight connections with built-in union. 1" female NPT fittings also available.

Pumping System:

Unit can be connected to central piping/pumping system from well field, boiler/tower or optional pump module can be installed inside unit for individual earth loop applications.

Copper Tube/Aluminum Fin Evaporator Coil:

Grooved copper tubing and enhanced aluminum fins provide maximum heat transfer and high energy efficiency. Evaporator coil constructed with hydrophilic fin stock that seals fin surface against aluminum oxide formation, is resistant to mold and mildew growth (tested to ASTM D3273, no growth) and reduces beading of condensate on the fin surface.

Cabinet:

Constructed of 20 gauge pre-painted or vinyl laminated galvanized steel. Choice of either two tone vinyl finish with "slate" front panels and "platinum" cabinet for designer appearance, or painted steel. Vinyl finish is very resistant to scratching and marring and is very easy to clean. Tamper resistant fasteners are provided for access panels. Unit includes built-in rollers for easy installation into wall sleeve and removal for service if necessary. Hinged, lockable front panel for filter service and access to primary functional electrical controls.

Insulation:

Cabinet is fully insulated with foil covered, high density fiberglass insulation with sealed edge treatment and special sound deadening insulation material in the compressor section. All insulation is designed to resist mold and mildew growth and facilitate ease of cleaning.



Electrical Components:

Are easily accessible for routine inspection and maintenance through front service panels. Circuit breaker standard on all 208/230V models and rotary disconnect standard on all 460V models. Circuit breaker/rotary disconnect access is through lockable access panel. Lock and key provided as standard equipment.

Hot Water Coil:

A plenum mounted hot water coil is available for both duct-free and ducted applications.

Air Filter:

Two-inch pleated MERV 8 filter is standard.

Compressor Control Module:

Built-in off-delay timer adjustable from 30 seconds to 5 minutes. Two-minute on-delay if power interrupt. 120-second bypass for low pressure control, and both soft and manual lockouts for high and low pressure controls.

High Pressure Switch:

Protects refrigerant circuit against excessively high pressure.

Low Pressure Switch:

Provides loss of charge protection plus protects against freeze-up of coaxial coil during heating mode due to water flow or temperature problems. Two switches are installed, and the factory wired switch is for fresh water applications.

Diagnostic Light:

System service - indicates high or low pressure switch operation for compressor protection. Located inside control panel.

Stainless Steel Drain Pan:

Provides extended life of the evaporator drain pan for maximum corrosion resistance.

Side Trim Piece Extension – Optional:

Trim kits available for covering the space between unit and wall for spaces from 4" to 12".

Optional Ventilation Packages:

Optional energy recovery ventilator can provide up to 450 cfm of outside air and exhaust through the unit while maintaining indoor comfort and humidity levels. Other available options include commercial room ventilator with exhaust, and barometric damper without exhaust. Outside wall and ventilation sleeve are required for installations with ventilation option.

Optional Ventilation Wall Sleeve:

Required for ventilation options only. Constructed of 16 gauge galvanized steel, coated with epoxy primer and a baked on polyester enamel paint, which allows it to withstand 1000 hours of salt spray tests per ASTM B117-03. Ordered separately.

Specifications - 2 and 3 Ton						
MODELS	QW2S2-A	QW2S2-B	QW2S2-C	QW3S2-A	QW3S2-B	QW3S2-C
ELECTRICAL RATING – 60 HZ	230/208 - 1	230/208 - 3	460 - 3	230/208 - 1	230/208 - 3	460 - 3
Operating Voltage Range	197-253		414-506	197-253		414-506
COMPRESSOR – CIRCUIT A						
Voltage	230/208		460	230/208		460
Rated Load Amps	9.1/10.6	5.1/5.9	3.2	13.2/15.8	10.1/12.0	6.0
Branch Circuit Selection Current	11.7	6.5	3.5	15.8	12	6.0
Lock Rotor Amps	58.3	55.4	28	83	73	38
MOTOR & EVAPORATOR						
Blower Motor HP/SPD	1/3 / Variable			1/2 / Variable		
Blower Motor – Amps	2.4			3.1		
Filter Sizes (inches) STD.	1 - 16x20x2 & 1 - 16x16x2			1 - 16x20x2 & 1 - 16x16x2		
SHIPPING WEIGHT – LBS.	530	530	550	535	535	555

Specifications - 4 and 5 Ton						
MODELS	QW4S2-A	QW4S2-B	QW4S2-C	QW5S2-A	QW5S2-B	QW5S2-C
ELECTRICAL RATING – 60 HZ	230/208 - 1	230/208 - 3	460 - 3	230/208 - 1	230/208 - 3	460 - 3
Operating Voltage Range	197-253		414-506	197-253		414-506
COMPRESSOR – CIRCUIT A						
Voltage	230/208		460	230/208		460
Rated Load Amps	18.7/22.1	12.4/14.7	6.7	21.1/23.3	12.8/14.2	6.3
Branch Circuit Selection Current	22.1	14.7	6.7	27.2	16.6	7.3
Lock Rotor Amps	104	83.1	41	152.9	110	52
MOTOR & EVAPORATOR						
Blower Motor HP/SPD	3/4 / Variable			3/4 / Variable		
Blower Motor – Amps	3.6			4.0		
Filter Sizes (inches) STD.	1 - 16x25x2 & 1 - 16x16x2			1 - 16x25x2 & 1 - 16x16x2		
SHIPPING WEIGHT – LBS.	555	555	575	620	620	645

See Page 9 for Electrical Specifications

Indoor Blower Performance – CFM (0.00" through 0.50" H ₂ O)						
Model	Rated ESP.	Max. ESP ①	Blower Only ②	Rated 1st Stage	2nd Stage De-Rated ③	2nd Stage Rated ④
QW2S2	0.10	0.5	600	800	900	950
QW3S2	0.15	0.5	675	900	1050	1150
QW4S2	0.20	0.5	825	1200	1300	1450
QW5S2	0.20	0.5	875	1400	1500	1650

NOTE: These units are equipped with a variable speed (ECM) indoor motor that automatically adjusts itself to maintain approximately the same rate of indoor airflow in both heating and cooling, dry and wet coil conditions, and at both 230/208 or 460 volts.

- ① Maximum ESP (inches WC) shown is with 2" MERV 6 pleated filter.
- ② Continuous CFM the total airflow being circulated during continuous blower operation.
- ③ Optional 2nd Stage CFM – the unit is factory shipped to operate on full 2nd Stage airflow. If the optional 2nd Stage airflow is desired, it requires removal of gray wire from "Y2" terminal of low voltage terminal strip in unit main control panel. This reduces system capacity performance by approximately 2% total (-4% Sensible, +2% Latent) at the same energy efficiency.
- ④ Rated CFM for ducted applications – required for maximum performance rating.

ISO 13256-1 Performance Data ①

MODEL	System Capacity Modulation	Fluid Flow Rate GPM	Airflow CFM	Ground Loop Heat Pump AHRI Certified to ISO 13256-1:1998			
				Cooling Brine Full Load 77°F Part Load 68°F		Heating Brine Full Load 32°F Part Load 41°F	
				Capacity BTUH	EER BTU/W	Capacity BTUH	COP
QW2S	Full Part	7.0	950 800	25,600	18.2	19,600	3.95
				20,200	24.8	15,600	4.00
QW3S	Full Part	8.0	1150 900	35,600	17.0	29,000	3.65
				27,200	22.5	22,000	3.85
QW4S	Full Part	9.0	1450 1200	49,500	17.2	36,000	3.35
				38,000	22.4	30,000	3.85
QW5S	Full Part	11.0	1650 1400	58,500	16.4	46,000	3.60
				45,500	21.6	38,000	4.05

MODEL	System Capacity Modulation	Fluid Flow Rate GPM	Airflow CFM	Water Loop Heat Pump AHRI Certified to ISO 13256-1:1998			
				Cooling — EWT 86°F		Heating — EWT 68°F	
				Capacity BTUH	EER BTU/W	Capacity BTUH	COP
QW2S	Full Part	6.1	950 800	24,800	15.6	31,600	5.20
				17,800	17.4	24,000	5.95
QW3S	Full Part	8.6	1150 900	35,400	15.0	44,600	4.30
				25,600	16.0	33,000	5.10
QW4S	Full Part	11.5	1450 1200	47,500	15.1	57,000	4.30
				35,000	16.0	43,000	4.80
QW5S	Full Part	13.7	1650 1400	56,500	14.5	69,500	4.40
				42,000	15.6	52,000	4.95

① ISO Standard 13256-1:1998, "Water to Air and Brine to Air Heat Pumps", which includes watt allowance for water pumping. Cooling capacity based on 80.6°F DB, 66.2°F WB entering air temperature. Heating capacity based on 68°F DB entering air temperature.

All 1-phase models meet the minimum efficiency requirements of the Energy Star (ES) efficiency program for Ground Loop applications. Currently, there is no ES efficiency program for 3-phase equipment or for Water Loop applications.

Correction Factors @ Increased Water Flows

Rated Flow Plus	Cooling		Heating	
	BtuH	Watts	BtuH	Watts
2 GPM	1.005	0.988	1.006	1.002
3 GPM	1.007	0.984	1.009	1.003
4 GPM	1.008	0.979	1.011	1.003



Bard is an
ISO 9001:2008
Certified Manufacturer

- Intertek ETL Listed to Standard for Safety Heating and Cooling Equipment ANSI/UL 1995/CSA 22.2 No. 236-05, Fourth Edition.

QW2S2

Full Load Capacities based upon rated flow of 7 GPM of 15% methanol/mass at 950 CFM airflow.

COOLING FULL LOAD

Entering Fluid Temp. (°F)	Entering Air Temp. (°F)	Total Capacity (MBtuH)	Sensible Capacity (MBtuH)	Sensible to Total Ratio	Power Input (KW)	Heat of Rejection (MBtuH)	EER
50°	70° DB 59° WB	25.2	19.1	0.75	1.02	28.3	21.1
60°		24.2	18.8	0.77	1.20	27.9	19.0
70°		23.3	18.4	0.79	1.37	27.5	16.9
80°		22.3	18.1	0.81	1.55	27.0	14.9
90°		21.4	17.8	0.83	1.73	26.6	12.8
100°		20.4	17.4	0.85	1.91	26.1	10.7
110°		19.5	17.1	0.87	2.08	25.7	8.6
50°	75° DB 63° WB	27.1	19.8	0.72	1.04	30.4	22.4
60°		26.1	19.5	0.74	1.21	30.0	20.2
70°		25.1	19.2	0.77	1.39	29.5	18.0
80°		24.0	18.9	0.79	1.57	29.1	15.8
90°		23.0	18.5	0.81	1.75	28.6	13.6
100°		22.0	18.2	0.83	1.92	28.2	11.5
110°		21.0	17.9	0.85	2.10	27.7	9.3
50°	80° DB 67° WB	29.0	20.5	0.70	1.06	32.6	23.7
60°		28.0	20.2	0.72	1.23	32.2	21.4
70°		26.9	19.9	0.74	1.41	31.7	19.1
80°		25.8	19.6	0.76	1.59	31.2	16.8
90°		24.8	19.3	0.78	1.76	30.8	14.5
100°		23.7	19.0	0.80	1.94	30.3	12.2
110°		22.6	18.7	0.82	2.12	29.9	9.9
50°	85° DB 71° WB	31.1	21.2	0.67	1.08	34.9	24.9
60°		30.0	20.9	0.69	1.25	34.5	22.5
70°		28.8	20.6	0.71	1.43	34.0	20.1
80°		27.7	20.3	0.73	1.61	33.5	17.8
90°		26.6	20.0	0.76	1.78	33.0	15.4
100°		25.4	19.7	0.78	1.96	32.6	13.0
110°		24.3	19.5	0.80	2.14	32.1	10.6

HEATING FULL LOAD

Entering Fluid Temp. (°F)	Entering Air Temp. (°F)	Total Capacity (MBtuH)	Leaving Air Temp. (°F)	Power Input (KW)	Heat of Absorption (MBtuH)	COP
25°	65°	19.0	82.5	1.51	13.6	3.7
30°		20.3	83.8	1.54	14.8	3.9
40°		22.9	86.2	1.60	17.2	4.2
50°		25.5	88.6	1.67	19.6	4.5
60°		28.8	91.7	1.76	22.7	4.8
70°		32.1	94.7	1.84	25.7	5.1
80°		35.4	97.8	1.93	28.7	5.4
25°	70°	18.5	87.2	1.55	13.2	3.5
30°		19.8	88.3	1.58	14.4	3.7
40°		22.4	90.7	1.65	16.7	4.0
50°		24.9	93.1	1.72	19.0	4.25
60°		28.2	96.1	1.80	22.0	4.6
70°		31.4	99.1	1.89	24.9	4.9
80°		34.7	102.1	1.98	27.9	5.2
25°	75°	18.7	92.3	1.74	12.9	3.2
30°		20.0	93.5	1.77	14.0	3.3
40°		22.6	95.9	1.85	16.2	3.6
50°		25.2	98.3	1.93	18.5	3.8
60°		28.5	101.4	2.02	21.3	4.1
70°		31.7	104.4	2.12	24.2	4.4
80°		35.0	107.4	2.22	27.1	4.7

Full Load Capacities based upon rated flow of 7 GPM of 15% methanol/mass at 800 CFM airflow.

COOLING PART LOAD

Entering Fluid Temp. (°F)	Entering Air Temp. (°F)	Total Capacity (MBtuH)	Sensible Capacity (MBtuH)	Sensible to Total Ratio	Power Input (KW)	Heat of Rejection (MBtuH)	EER
50°	70° DB 59° WB	20.0	16.1	0.79	0.58	21.8	27.0
60°		19.0	15.7	0.82	0.72	21.2	23.9
70°		17.9	15.2	0.85	0.86	20.5	20.8
80°		16.9	14.7	0.87	1.00	19.9	17.8
90°		15.9	14.2	0.90	1.14	19.3	14.7
100°		14.8	13.8	0.93	1.28	18.6	11.6
110°		13.8	13.3	0.95	1.42	18.0	8.5
50°	75° DB 63° WB	21.5	16.7	0.77	0.59	23.4	28.6
60°		20.4	16.3	0.79	0.73	22.7	25.4
70°		19.3	15.8	0.82	0.87	22.1	22.1
80°		18.2	15.3	0.85	1.01	21.4	18.9
90°		17.1	14.9	0.87	1.15	20.8	15.7
100°		16.0	14.4	0.90	1.29	20.1	12.4
110°		14.9	13.9	0.93	1.43	19.4	9.2
50°	80° DB 67° WB	23.0	17.3	0.74	0.60	25.1	30.3
60°		21.9	16.9	0.77	0.74	24.4	26.9
70°		20.7	16.4	0.79	0.88	23.7	23.5
80°		19.5	15.9	0.82	1.02	23.0	20.1
90°		18.4	15.5	0.85	1.16	22.3	16.6
100°		17.2	15.0	0.87	1.30	21.6	13.2
110°		16.0	14.5	0.90	1.44	20.9	9.8
50°	85° DB 71° WB	24.7	17.9	0.71	0.62	26.9	31.9
60°		23.4	17.4	0.74	0.76	26.1	28.4
70°		22.2	17.0	0.77	0.89	25.4	24.8
80°		20.9	16.5	0.79	1.03	24.7	21.2
90°		19.7	16.1	0.82	1.17	24.0	17.6
100°		18.5	15.6	0.84	1.31	23.2	14.1
110°		17.2	15.1	0.87	1.45	22.5	10.5

HEATING PART LOAD

Entering Fluid Temp. (°F)	Entering Air Temp. (°F)	Total Capacity (MBtuH)	Leaving Air Temp. (°F)	Power Input (KW)	Heat of Absorption (MBtuH)	COP
25°	65°	11.1	77.8	1.12	7.2	2.9
30°		12.7	79.7	1.12	8.7	3.3
40°		15.9	83.4	1.13	11.9	4.1
50°		19.0	87.0	1.14	15.0	4.9
60°		21.4	89.8	1.14	17.4	5.5
70°		23.8	92.6	1.15	19.9	6.1
80°		26.2	95.4	1.15	22.3	6.7
25°	70°	10.9	82.6	1.15	6.9	2.8
30°		12.4	84.4	1.15	8.5	3.2
40°		15.5	87.9	1.16	11.5	3.9
50°		18.6	91.5	1.17	14.6	4.7
60°		21.0	94.2	1.18	16.9	5.2
70°		23.3	97.0	1.18	19.3	5.79
80°		25.7	99.7	1.19	21.6	6.35
25°	75°	11.0	87.7	1.29	6.7	2.5
30°		12.5	89.5	1.29	8.2	2.8
40°		15.7	93.1	1.30	11.2	3.5
50°		18.8	96.8	1.31	14.2	4.2
60°		21.2	99.5	1.32	16.4	4.7
70°		23.6	102.3	1.33	18.7	5.2
80°		25.9	105.0	1.33	21.0	5.7

QW3S2

Full Load Capacities based upon rated flow of 8 GPM of 15% methanol/mass at 1150 CFM airflow.

COOLING FULL LOAD

Entering Fluid Temp. (°F)	Entering Air Temp. (°F)	Total Capacity (MBtuH)	Sensible Capacity (MBtuH)	Sensible to Total Ratio	Power Input (KW)	Heat of Rejection (MBtuH)	EER
50°	70° DB 59° WB	32.5	22.0	0.67	1.42	36.9	19.3
60°		31.9	22.1	0.69	1.70	37.0	17.5
70°		31.2	22.2	0.71	1.98	37.2	15.8
80°		30.5	22.3	0.73	2.26	37.3	14.0
90°		29.8	22.4	0.75	2.53	37.4	12.2
100°		29.1	22.6	0.77	2.81	37.5	10.4
110°		28.4	22.7	0.80	3.09	37.7	8.6
50°	75° DB 63° WB	34.9	22.8	0.65	1.45	39.6	20.5
60°		34.2	23.0	0.67	1.73	39.8	18.6
70°		33.5	23.1	0.69	2.00	40.0	16.7
80°		32.8	23.3	0.71	2.28	40.1	14.9
90°		32.1	23.4	0.73	2.56	40.3	13.0
100°		31.4	23.6	0.75	2.83	40.5	11.1
110°		30.7	23.8	0.77	3.11	40.6	9.2
50°	80° DB 67° WB	37.5	23.6	0.63	1.48	42.5	21.7
60°		36.7	23.8	0.65	1.75	42.7	19.7
70°		36.0	24.0	0.67	2.03	42.9	17.7
80°		35.3	24.2	0.69	2.31	43.1	15.8
90°		34.5	24.4	0.71	2.58	43.4	13.8
100°		33.8	24.6	0.73	2.86	43.6	11.8
110°		33.1	24.8	0.75	3.14	43.8	9.8
50°	85° DB 71° WB	40.1	24.4	0.60	1.51	45.5	22.8
60°		39.3	24.6	0.62	1.78	45.8	20.8
70°		38.6	24.8	0.64	2.06	46.0	18.7
80°		37.8	25.1	0.66	2.34	46.3	16.7
90°		37.1	25.3	0.68	2.61	46.5	14.6
100°		36.3	25.6	0.70	2.89	46.8	12.6
110°		35.5	25.8	0.72	3.17	47.0	10.5

HEATING FULL LOAD

Entering Fluid Temp. (°F)	Entering Air Temp. (°F)	Total Capacity (MBtuH)	Leaving Air Temp. (°F)	Power Input (KW)	Heat of Absorption (MBtuH)	COP
25°	65°	26.1	86.0	2.19	18.4	3.5
30°		28.2	87.7	2.27	20.2	3.6
40°		32.5	91.2	2.43	24.0	3.9
50°		36.8	94.7	2.58	27.8	4.2
60°		40.5	97.6	2.68	31.1	4.4
70°		44.2	100.6	2.78	34.5	4.7
80°		47.9	103.5	2.87	37.8	4.9
25°	70°	25.5	90.5	2.25	17.8	3.3
30°		27.6	92.2	2.33	19.6	3.5
40°		31.8	95.6	2.49	23.3	3.7
50°		36.0	99.0	2.65	27.0	4.0
60°		39.6	101.9	2.75	30.2	4.2
70°		43.2	104.8	2.85	33.5	4.4
80°		46.8	107.7	2.95	36.7	4.7
25°	75°	25.8	95.8	2.53	17.3	3.0
30°		27.9	97.5	2.62	19.1	3.1
40°		32.1	100.9	2.80	22.6	3.4
50°		36.4	104.3	2.98	26.1	3.6
60°		40.0	107.2	3.09	29.3	3.8
70°		43.7	110.2	3.20	32.5	4.0
80°		47.3	113.1	3.31	35.6	4.2

Full Load Capacities based upon rated flow of 8 GPM of 15% methanol/mass at 900 CFM airflow.

COOLING PART LOAD

Entering Fluid Temp. (°F)	Entering Air Temp. (°F)	Total Capacity (MBtuH)	Sensible Capacity (MBtuH)	Sensible to Total Ratio	Power Input (KW)	Heat of Rejection (MBtuH)	EER
50°	70° DB 59° WB	26.5	18.4	0.68	0.72	28.7	27.0
60°		24.9	17.8	0.71	0.93	27.8	23.7
70°		23.4	17.2	0.74	1.15	26.9	20.4
80°		21.8	16.6	0.77	1.36	25.9	17.1
90°		20.3	16.0	0.79	1.57	25.0	13.8
100°		18.7	15.4	0.82	1.79	24.1	10.5
110°		17.1	14.8	0.85	2.00	23.1	7.1
50°	75° DB 63° WB	28.5	19.1	0.66	0.73	30.8	28.7
60°		26.8	18.5	0.68	0.94	29.9	25.2
70°		25.1	17.9	0.71	1.16	28.9	21.7
80°		23.5	17.3	0.74	1.37	27.9	18.2
90°		21.8	16.7	0.77	1.59	26.9	14.7
100°		20.2	16.1	0.80	1.80	25.9	11.2
110°		18.5	15.5	0.83	2.02	25.0	7.7
50°	80° DB 67° WB	30.5	19.8	0.63	0.75	33.1	30.3
60°		28.8	19.2	0.66	0.96	32.0	26.7
70°		27.0	18.6	0.69	1.18	31.0	23.0
80°		25.2	18.0	0.72	1.39	30.0	19.3
90°		23.5	17.4	0.75	1.61	28.9	15.6
100°		21.7	16.8	0.77	1.82	27.9	11.9
110°		19.9	16.2	0.80	2.04	26.9	8.2
50°	85° DB 71° WB	32.7	20.4	0.61	0.76	35.4	32.0
60°		30.8	19.8	0.64	0.98	34.3	28.1
70°		28.9	19.3	0.67	1.19	33.2	24.3
80°		27.1	18.7	0.69	1.41	32.1	20.4
90°		25.2	18.1	0.72	1.62	31.1	16.5
100°		23.3	17.5	0.75	1.84	30.0	12.7
110°		21.4	16.9	0.78	2.05	28.9	8.8

HEATING PART LOAD

Entering Fluid Temp. (°F)	Entering Air Temp. (°F)	Total Capacity (MBtuH)	Leaving Air Temp. (°F)	Power Input (KW)	Heat of Absorption (MBtuH)	COP
25°	65°	17.4	82.9	1.55	12.0	3.3
30°		19.0	84.6	1.57	13.5	3.6
40°		22.2	87.8	1.61	16.6	4.0
50°		25.4	91.1	1.65	19.6	4.5
60°		28.8	94.6	1.70	22.9	5.0
70°		32.2	98.2	1.75	26.1	5.4
80°		35.7	101.7	1.81	29.4	5.8
25°	70°	17.1	87.5	1.59	11.6	3.2
30°		18.6	89.1	1.61	13.1	3.4
40°		21.7	92.3	1.65	16.1	3.8
50°		24.8	95.5	1.69	19.0	4.3
60°		28.2	99.0	1.75	22.2	4.7
70°		31.5	102.4	1.80	25.4	5.1
80°		34.9	105.9	1.86	28.5	5.5
25°	75°	17.2	92.7	1.79	11.3	2.8
30°		18.8	94.3	1.81	12.7	3.0
40°		21.9	97.6	1.85	15.6	3.5
50°		25.1	100.8	1.90	18.5	3.9
60°		28.5	104.3	1.96	21.5	4.2
70°		31.8	107.8	2.02	24.6	4.6
80°		35.2	111.2	2.08	27.7	5.0

QW4S2

Full Load Capacities based upon rated flow of 9 GPM of 15% methanol/mass at 1450 CFM airflow.

COOLING FULL LOAD

Entering Fluid Temp. (°F)	Entering Air Temp. (°F)	Total Capacity (MBtuH)	Sensible Capacity (MBtuH)	Sensible to Total Ratio	Power Input (KW)	Heat of Rejection (MBtuH)	EER
50°	70° DB 59° WB	52.1	32.2	0.59	2.09	58.5	21.4
60°		48.8	31.4	0.63	2.40	56.1	19.1
70°		45.5	30.5	0.67	2.71	53.7	16.8
80°		42.1	29.7	0.71	3.02	51.2	14.4
90°		38.8	28.9	0.75	3.33	48.8	12.1
100°		35.5	28.1	0.79	3.63	46.4	9.8
110°		32.2	27.2	0.83	3.94	43.9	7.4
50°	75° DB 63° WB	56.0	33.4	0.57	2.13	62.9	22.7
60°		52.4	32.6	0.61	2.44	60.3	20.3
70°		48.9	31.8	0.65	2.74	57.7	17.8
80°		45.4	31.0	0.69	3.05	55.2	15.4
90°		41.8	30.2	0.73	3.36	52.6	12.9
100°		38.3	29.4	0.77	3.67	50.0	10.4
110°		34.7	28.5	0.81	3.97	47.5	8.0
50°	80° DB 67° WB	60.0	34.6	0.55	2.17	67.4	24.1
60°		56.3	33.8	0.59	2.47	64.7	21.5
70°		52.5	33.0	0.63	2.78	62.0	18.9
80°		48.7	32.2	0.67	3.09	59.3	16.3
90°		45.0	31.4	0.70	3.39	56.5	13.7
100°		41.2	30.6	0.74	3.7	53.8	11.1
110°		37.4	29.8	0.78	4.01	51.1	8.6
50°	85° DB 71° WB	64.3	35.7	0.53	2.21	72.2	25.3
60°		60.3	34.9	0.57	2.51	69.3	22.6
70°		56.3	34.2	0.61	2.82	66.4	19.9
80°		52.3	33.4	0.64	3.13	63.6	17.2
90°		48.3	32.6	0.68	3.43	60.7	14.5
100°		44.2	31.8	0.72	3.74	57.8	11.8
110°		40.2	31.0	0.76	4.04	54.9	9.1

HEATING FULL LOAD

Entering Fluid Temp. (°F)	Entering Air Temp. (°F)	Total Capacity (MBtuH)	Leaving Air Temp. (°F)	Power Input (KW)	Heat of Absorption (MBtuH)	COP
25°	65°	33.0	87.6	2.89	22.8	3.4
30°		35.3	89.2	2.97	24.8	3.5
40°		39.9	92.4	3.12	29.0	3.7
50°		44.6	95.6	3.26	33.1	4.0
60°		50.0	99.3	3.47	37.8	4.2
70°		55.4	103.0	3.67	42.6	4.4
80°		60.9	106.7	3.88	47.3	4.6
25°	70°	32.2	92.1	2.97	22.1	3.2
30°		34.5	93.7	3.05	24.1	3.3
40°		39.1	96.8	3.20	28.1	3.6
50°		43.6	99.9	3.35	32.2	3.8
60°		48.9	103.5	3.56	36.7	4.0
70°		54.2	107.2	3.77	41.3	4.2
80°		59.5	110.8	3.98	45.9	4.4
25°	75°	32.6	97.3	3.33	21.4	2.9
30°		34.9	98.9	3.42	23.4	3.0
40°		39.5	102.1	3.59	27.3	3.2
50°		44.1	105.2	3.76	31.2	3.4
60°		49.4	108.9	4.00	35.6	3.6
70°		54.8	112.6	4.23	40.1	3.8
80°		60.2	116.3	4.47	44.5	4.0

Full Load Capacities based upon rated flow of 9 GPM of 15% methanol/mass at 1200 CFM airflow.

COOLING PART LOAD

Entering Fluid Temp. (°F)	Entering Air Temp. (°F)	Total Capacity (MBtuH)	Sensible Capacity (MBtuH)	Sensible to Total Ratio	Power Input (KW)	Heat of Rejection (MBtuH)	EER
50°	70° DB 59° WB	37.4	26.7	0.71	1.07	40.8	26.6
60°		35.4	25.5	0.72	1.36	39.6	23.5
70°		33.4	24.4	0.73	1.64	38.4	20.3
80°		31.4	23.3	0.74	1.93	37.2	17.2
90°		29.4	22.2	0.76	2.21	36.0	14.1
100°		27.4	21.1	0.77	2.50	34.9	11.0
110°		25.4	20.0	0.78	2.78	33.7	7.9
50°	75° DB 63° WB	40.2	27.7	0.68	1.09	43.8	28.2
60°		38.1	26.6	0.69	1.38	42.5	24.9
70°		36.0	25.4	0.71	1.66	41.3	21.6
80°		33.8	24.3	0.72	1.95	40.1	18.3
90°		31.7	23.2	0.73	2.23	38.8	15.0
100°		29.6	22.1	0.75	2.52	37.6	11.7
110°		27.4	20.9	0.76	2.80	36.4	8.5
50°	80° DB 67° WB	43.1	28.7	0.66	1.12	46.9	29.8
60°		40.9	27.5	0.67	1.40	45.6	26.4
70°		38.6	26.4	0.68	1.69	44.4	22.9
80°		36.3	25.3	0.70	1.97	43.1	19.4
90°		34.1	24.1	0.71	2.26	41.8	16.0
100°		31.8	23.0	0.72	2.54	40.5	12.5
110°		29.5	21.9	0.74	2.83	39.2	9.1
50°	85° DB 71° WB	46.2	29.6	0.63	1.14	20.3	31.4
60°		43.8	28.5	0.65	1.42	48.9	27.8
70°		41.4	27.3	0.66	1.71	47.5	24.2
80°		39.0	26.2	0.67	1.99	46.2	20.6
90°		36.6	25.0	0.69	2.28	44.8	16.9
100°		34.1	23.9	0.70	2.57	43.5	13.3
110°		31.7	22.8	0.71	2.85	42.1	9.7

HEATING PART LOAD

Entering Fluid Temp. (°F)	Entering Air Temp. (°F)	Total Capacity (MBtuH)	Leaving Air Temp. (°F)	Power Input (KW)	Heat of Absorption (MBtuH)	COP
25°	65°	23.1	83.6	2.09	15.7	3.2
30°		25.1	85.2	2.12	17.6	3.5
40°		29.0	88.4	2.17	21.4	3.9
50°		32.9	91.5	2.22	25.2	4.3
60°		36.4	94.3	2.26	28.5	4.7
70°		39.9	97.1	2.30	31.9	5.1
80°		43.4	99.9	2.34	35.2	5.5
25°	70°	22.6	88.2	2.15	15.2	3.1
30°		24.5	89.7	2.18	17.1	3.3
40°		28.4	92.8	2.23	20.7	3.7
50°		32.2	95.9	2.28	24.4	4.1
60°		35.6	98.7	2.32	27.7	4.5
70°		39.0	101.4	2.36	30.9	4.8
80°		42.4	104.1	2.40	34.2	5.2
25°	75°	22.8	93.4	2.42	14.8	2.8
30°		24.8	94.9	2.44	16.6	3.0
40°		28.7	98.1	2.50	20.1	3.3
50°		32.6	101.2	2.56	23.7	3.7
60°		36.0	104.0	2.60	26.9	4.0
70°		39.4	106.7	2.65	30.0	4.4
80°		42.9	109.5	2.70	33.2	4.7

QW5S2

Full Load Capacities based upon rated flow of 11 GPM of 15% methanol/mass at 1650 CFM airflow.

COOLING FULL LOAD

Entering Fluid Temp. (°F)	Entering Air Temp. (°F)	Total Capacity (MBtuH)	Sensible Capacity (MBtuH)	Sensible to Total Ratio	Power Input (KW)	Heat of Rejection (MBtuH)	EER
50°	70° DB 59° WB	55.3	36.1	0.65	2.37	62.6	19.6
60°		53.2	35.3	0.66	2.82	61.8	17.6
70°		51.1	34.5	0.68	3.26	61.0	15.7
80°		49.0	33.7	0.69	3.71	60.2	13.7
90°		46.9	32.9	0.70	4.15	59.4	11.74
100°		44.8	32.1	0.72	4.60	58.6	9.7
110°		42.7	31.3	0.73	5.04	57.8	7.8
50°	75° DB 63° WB	59.4	37.5	0.63	2.41	67.2	20.8
60°		57.2	36.7	0.64	2.86	66.4	18.7
70°		55.0	35.9	0.65	3.30	65.6	16.6
80°		52.7	35.2	0.67	3.75	64.8	14.6
90°		50.5	34.4	0.68	4.19	64.0	12.5
100°		48.3	33.6	0.69	4.64	63.2	10.4
110°		46.1	32.8	0.71	5.08	62.4	8.4
50°	80° DB 67° WB	63.7	38.8	0.60	2.46	72.1	22.0
60°		61.3	38.1	0.62	2.90	71.2	19.
70°		59.0	37.3	0.63	3.35	70.4	17.6
80°		56.7	36.5	0.65	3.79	69.6	15.5
90°		54.3	35.8	0.66	4.24	68.8	13.3
100°		52.0	35.0	0.67	4.68	68.0	11.1
110°		49.7	34.2	0.69	5.12	67.2	8.9
50°	85° DB 71° WB	68.2	40.1	0.58	2.51	77.1	23.1
60°		65.7	39.4	0.60	2.95	76.3	20.9
70°		63.2	38.6	0.61	3.40	75.5	18.6
80°		60.8	37.9	0.62	3.84	74.7	16.3
90°		58.3	37.1	0.64	4.28	73.8	14.1
100°		55.8	36.4	0.65	4.73	73.0	11.8
110°		53.4	35.6	0.66	5.17	72.2	9.5

HEATING FULL LOAD

Entering Fluid Temp. (°F)	Entering Air Temp. (°F)	Total Capacity (MBtuH)	Leaving Air Temp. (°F)	Power Input (KW)	Heat of Absorption (MBtuH)	COP
25°	65°	42.2	91.9	3.83	28.7	3.2
30°		45.0	93.7	3.94	31.1	3.3
40°		50.6	97.3	4.18	35.9	3.5
50°		56.3	100.9	4.42	40.7	3.7
60°		62.7	105.0	4.71	46.1	3.9
70°		69.1	109.1	5.00	51.5	4.0
80°		75.4	113.2	5.28	56.9	4.2
25°	70°	41.3	96.3	3.93	27.8	3.1
30°		44.0	98.1	4.05	30.2	3.2
40°		49.5	101.6	4.3	34.8	3.4
50°		55.0	105.1	4.54	39.5	3.5
60°		61.3	109.1	4.84	44.7	3.7
70°		67.5	113.1	5.13	50.0	3.9
80°		73.8	117.1	5.43	55.2	4.0
25°	75°	41.7	101.6	4.41	27.0	2.8
30°		44.5	103.4	4.55	29.3	2.9
40°		50.0	107.0	4.82	33.8	3.0
50°		55.6	110.5	5.10	38.3	3.2
60°		61.9	114.5	5.43	43.4	3.3
70°		68.2	118.6	5.76	48.5	3.5
80°		74.6	122.6	6.09	53.6	3.6

Full Load Capacities based upon rated flow of 11 GPM of 15% methanol/mass at 1400 CFM airflow.

COOLING PART LOAD

Entering Fluid Temp. (°F)	Entering Air Temp. (°F)	Total Capacity (MBtuH)	Sensible Capacity (MBtuH)	Sensible to Total Ratio	Power Input (KW)	Heat of Rejection (MBtuH)	EER
50°	70° DB 59° WB	43.4	29.4	0.67	1.41	47.8	23.7
60°		41.4	28.6	0.69	1.78	46.9	21.0
70°		39.5	27.8	0.70	2.16	46.0	18.3
80°		37.5	26.9	0.72	2.53	45.2	15.6
90°		35.6	26.1	0.74	2.91	44.3	12.9
100°		33.6	25.3	0.75	3.29	43.4	10.2
110°		31.6	24.5	0.77	3.66	42.6	7.5
50°	75° DB 63° WB	46.6	30.5	0.65	1.43	51.3	25.1
60°		44.5	29.7	0.66	1.81	50.4	22.3
70°		42.5	28.9	0.68	2.19	49.5	19.4
80°		40.4	28.1	0.70	2.56	48.6	16.6
90°		38.3	27.3	0.71	2.94	47.7	13.8
100°		36.2	26.5	0.73	3.31	46.9	10.9
110°		34.2	25.7	0.75	3.69	46.0	8.1
50°	80° DB 67° WB	50.0	31.6	0.62	1.46	55.0	26.5
60°		47.8	30.8	0.64	1.84	54.1	23.6
70°		45.6	30.0	0.66	2.22	53.2	20.6
80°		43.4	29.2	0.67	2.59	52.2	17.6
90°		41.2	28.4	0.69	2.97	51.3	14.6
100°		39.0	27.6	0.71	3.35	50.4	11.7
110°		36.8	26.8	0.72	3.72	49.5	8.7
50°	85° DB 71° WB	53.5	32.6	0.60	1.49	58.9	28.0
60°		51.2	31.8	0.62	1.87	57.9	24.9
70°		48.9	31.1	0.64	2.25	57.0	21.7
80°		46.5	30.3	0.65	2.62	56.0	18.6
90°		44.2	29.5	0.67	3.00	55.1	15.5
100°		41.9	28.7	0.68	3.38	54.1	12.4
110°		39.5	27.9	0.70	3.76	53.2	9.3

HEATING PART LOAD

Entering Fluid Temp. (°F)	Entering Air Temp. (°F)	Total Capacity (MBtuH)	Leaving Air Temp. (°F)	Power Input (KW)	Heat of Absorption (MBtuH)	COP
25°	65°	30.8	87.8	2.85	20.7	3.2
30°		32.9	89.4	2.90	22.7	3.3
40°		37.2	92.6	3.00	26.6	3.6
50°		41.5	95.8	3.11	30.6	3.9
60°		46.4	99.4	3.21	35.2	4.2
70°		51.4	103.0	3.32	39.7	4.5
80°		56.3	106.7	3.43	44.3	4.8
25°	70°	30.1	92.3	2.93	20.1	3.0
30°		32.2	93.9	2.98	22.0	3.2
40°		36.4	97.0	3.09	25.9	3.4
50°		40.6	100.1	3.19	29.7	3.7
60°		45.4	103.6	3.30	34.1	4.0
70°		50.2	107.2	3.41	38.6	4.3
80°		55.0	110.7	3.52	43.0	4.6
25°	75°	30.4	97.5	3.29	19.5	2.7
30°		32.6	99.1	3.35	21.4	2.9
40°		36.8	102.3	3.46	25.1	3.1
50°		41.0	105.4	3.58	28.8	3.4
60°		45.9	109.0	3.71	33.1	3.6
70°		50.8	112.6	3.83	37.4	3.9
80°		55.6	116.2	3.95	41.7	4.1

Water Coil Pressure Drop (Fresh Water)

Model	QW2S & QW3S		QW4S		QW5S	
	PSID	Ft. Hd.	PSID	Ft. Hd.	PSID	Ft. Hd.
3	0.1	0.23				
4	0.5	1.15	0.9	2.08		
5	1.2	2.77	1.4	3.23		
6	1.7	3.92	2.3	5.31		
7	2.3	5.31	3.2	7.38	2	4.61
8	3.1	7.15	4.1	9.46	2.5	5.77
9	4.1	9.46	5.1	11.77	3.2	7.38
10			6.1	14.07	3.9	9.00
11			7.1	16.38	4.7	10.84
12			8.2	18.92	5.5	12.69
13			9.4	21.69	6.4	14.76
14			10.6	24.45	7.3	16.84
15					8.1	18.69
16					9	20.76
17					9.9	22.84
18						

NOTE:

For pump options 3, 4 and 5 add 1.5 head to Table values as allowance for QW*S internal piping.

Additional feet head allowance for external piping to loop must be included and determined by others.

Required Flow Rates for Water Loop Installations

	QW2S	QW3S	QW4S	QW5S
Flow rate required GPM fresh water	6.1	8.6	11.5	13.7

Required Flow Rates for Ground Loop Installations

	QW2S	QW3S	QW4S	QW5S
Flow rate required GPM Methanol, Propylene Glycol or Ethanol ①	7	8	9	11

① See Antifreeze table below.

Antifreeze Percentages by Volume for Ground Loop Installations ①

Type	Minimum Temperature for Freeze Protection			
	10°F (-12.2°C)	15°F (-9.4°C)	20°F (-6.7°C)	25°F (-3.9°C)
Methanol	25%	21%	16%	10%
Ethanol ②	29%	25%	20%	14%
100% USP Food Grade Propylene Glycol	27%	24%	20%	13%

① Loop antifreeze protection must be determined based on loop design and geographic location.

② Must not be denatured with any petroleum based product.

Unit Charge Rates

UNIT	Std. Unit - Lbs.	Dehum. Units - Lbs.
QW2S2 - High Efficiency Step Capacity Geothermal Indoor Heat Pump	6.1875	6.1875
QW3S2 - High Efficiency Step Capacity Geothermal Indoor Heat Pump	6.00	6.00
QW4S2 - High Efficiency Step Capacity Geothermal Indoor Heat Pump	7.0625	7.0625
QW5S2 - High Efficiency Step Capacity Geothermal Indoor Heat Pump	7.625	7.625

Ventilation System Packages — Optional

Q-TEC models are designed to provide optional ventilation packages to meet all of your ventilation and indoor air quality requirements. All ventilation packages are factory installed. If no option is ordered, the ventilation intake and exhaust are sealed with a blank-off plate.

NOTE: A ventilation wall sleeve QWVS42 with outdoor louver grille is required for all installations that intend to utilize one of the built-in ventilation options of the QW*S Series heat pumps. If a ventilation option is not to be utilized, do not order ventilation wall sleeve.

COMMERCIAL ROOM VENTILATOR (Option V)

OPTIONAL

The built-in commercial room ventilator is internally mounted and allows outside ventilation air, up to 50% of the total airflow rating of the unit, to be introduced through the ventilation louver grille. It includes a built-in exhaust air damper. Spring return on power loss or deactivation. The commercial room ventilator (CRV) is a simple and innovative approach to improving the indoor air quality by providing fresh air intake and exhaust capability through the CRV. The damper can be easily adjusted to control the amount of fresh air supplied into the building. The CRV can be controlled by indoor blower operation or field controlled based on room occupancy. Complies with ANSI/ASHRAE Standard 62.1 "Ventilation for Acceptable Indoor Air Quality".

COMMERCIAL ROOM VENTILATOR (Option W)

OPTIONAL

The built-in commercial room ventilator is internally mounted and allows outside ventilation air, up to 50% of the total airflow rating of the unit, to be introduced through the ventilation louver grille. It includes a built-in exhaust air damper. Spring return on power loss or deactivation. The commercial room ventilator (CRV) is a simple and innovative approach to improving the indoor air quality by providing fresh air intake and exhaust capability through the CRV. The damper can be easily adjusted to control the amount of fresh air supplied into the building. The CRV can be controlled by indoor blower operation or field controlled based on room occupancy. Complies with ANSI/ASHRAE Standard 62.1 "Ventilation for Acceptable Indoor Air Quality". Option W has 0 - 10 VDC actuator for DDC control by others.

ENERGY RECOVERY VENTILATOR (Option R)

OPTIONAL

The energy recovery ventilator (ERV) is a highly innovative approach to meeting indoor air quality ventilation requirements as established by ANSI/ASHRAE Standard 62.1. The ERV is internally mounted and allows up to 450 CFM (depending upon speed setting) of fresh air and exhaust through the unit while maintaining superior indoor comfort and humidity levels. In most cases this can be accomplished without increasing equipment sizing or operating costs. Heat transfer efficiency is up to 64% during summer and 79% during winter conditions.

The ERV consists of a unique "rotary energy recovery cassette" that provides effective sensible and latent heat transfer capabilities during summer and winter conditions. Various control schemes are addressed including limiting ventilation during building occupancy only. The ERV has a filter for the exhaust air to keep the rotary wheels clean and free of any debris introduced through the room return air grille. The intake and exhaust rates can be independently selected. Factory set on medium intake and low exhaust. Intake and exhaust air paths have shut-off dampers to eliminate the ingress of outside air when ventilation system is off.

ENERGY RECOVERY VENTILATOR (Option S)

OPTIONAL

The energy recovery ventilator (ERV) is a highly innovative approach to meeting indoor air quality ventilation requirements as established by ANSI/ASHRAE Standard 62.1. The ERV is internally mounted and allows up to 450 CFM (depending upon speed setting) of fresh air and exhaust through the unit while maintaining superior indoor comfort and humidity levels. In most cases this can be accomplished without increasing equipment sizing or operating costs. Heat transfer efficiency is up to 64% during summer and 79% during winter conditions.

The ERV consists of a unique "rotary energy recovery cassette" that provides effective sensible and latent heat transfer capabilities during summer and winter conditions. Various control schemes are addressed including limiting ventilation during building occupancy only. The ERV has a filter for the exhaust air to keep the rotary wheels clean and free of any debris introduced through the room return air grille. The intake and exhaust rates can be independently selected. Factory set on medium intake and low exhaust. Intake and exhaust air paths have shut-off dampers to eliminate the ingress of outside air when ventilation system is off.

Equipped with Intelligent Frost Control that cycles the ventilation air intake damper closed for 4 minutes out of every 32 minutes of ERV operation when the outdoor air is below 10°F. This sequence allows the ERV to operate with zero outdoor air intake and allows conditioned room air to defrost any accumulated frost if present on the cassette wheels.

ENERGY RECOVERY VENTILATOR (Option T)

OPTIONAL

The energy recovery ventilator (ERV) is a highly innovative approach to meeting indoor air quality ventilation requirements as established by ANSI/ASHRAE Standard 62.1. The ERV is internally mounted and allows up to 450 CFM (depending upon speed setting) of fresh air and exhaust through the unit while maintaining superior indoor comfort and humidity levels. In most cases this can be accomplished without increasing equipment sizing or operating costs. Heat transfer efficiency is up to 64% during summer and 79% during winter conditions.

The ERV consists of a unique "rotary energy recovery cassette" that provides effective sensible and latent heat transfer capabilities during summer and winter conditions. Various control schemes are addressed including limiting ventilation during building occupancy only. The ERV has a filter for the exhaust air to keep the rotary wheels clean and free of any debris introduced through the room return air grille. The intake and exhaust rates can be independently selected. Factory set on medium intake and low exhaust. Intake and exhaust air paths have shut-off dampers to eliminate the ingress of outside air when ventilation system is off.

Additional controls to permit lower ventilation intake airflow (105 - 225 CFM based on selected intake blower speed and room tightness) and controlled by an occupancy signal, and then can increase to maximum of 450 CFM and controlled by CO₂ input signal.

ELECTRICAL SPECIFICATIONS

MODEL	RATED VOLTS & PHASE	NO. FIELD POWER CIRCUITS	③ MINIMUM CIRCUIT AMPACITY	① MAXIMUM EXTERNAL FUSE OR CIRCUIT BREAKER	② FIELD POWER WIRE SIZE	② GROUND WIRE SIZE
QW2S2-A0Z	230/208-1	1	19	30	10	10
QW2S2-B0Z	230/208-3	1	12	20	12	12
QW2S2-C0Z	460-3	1	7.5	15	14	14
QW3S2-A0Z	230/208-1	1	25	40	8	10
QW3S2-B0Z	230/208-3	1	20	30	10	10
QW3S2-C0Z	460-3	1	11	15	14	14
QW4S2-A0Z	230/208-1	1	33	50	8	10
QW4S2-B0Z	230/208-3	1	24	35	8	10
QW4S2-C0Z	460-3	1	13	20	12	14
QW5S2-A0Z	230/208-1	1	41	60	6	10
QW5S2-B0Z	230/208-3	1	28	40	8	10
QW5S2-C0Z	460-3	1	13	20	12	12

① Maximum size of the time delay fuse or HACR type circuit breaker for protection of field wiring conductors.

② Based on 75°C copper wire. All wiring must conform to the National Electrical Code and all local codes.

③ These "Minimum Circuit Ampacity" values are to be used for sizing the field power conductors. Refer to the National Electrical Code (latest revision) article 310 for power conductor sizing.

QW2S CRV AIRFLOW VS. DAMPER POSITION

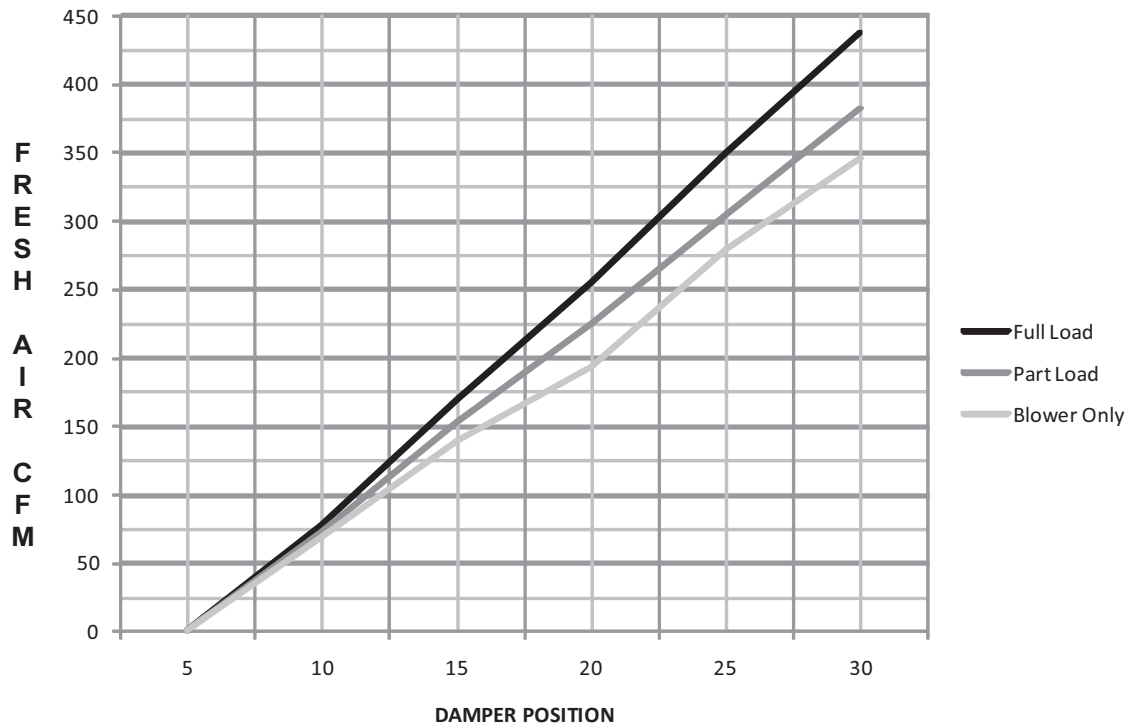

QW3S CRV AIRFLOW VS. DAMPER POSITION

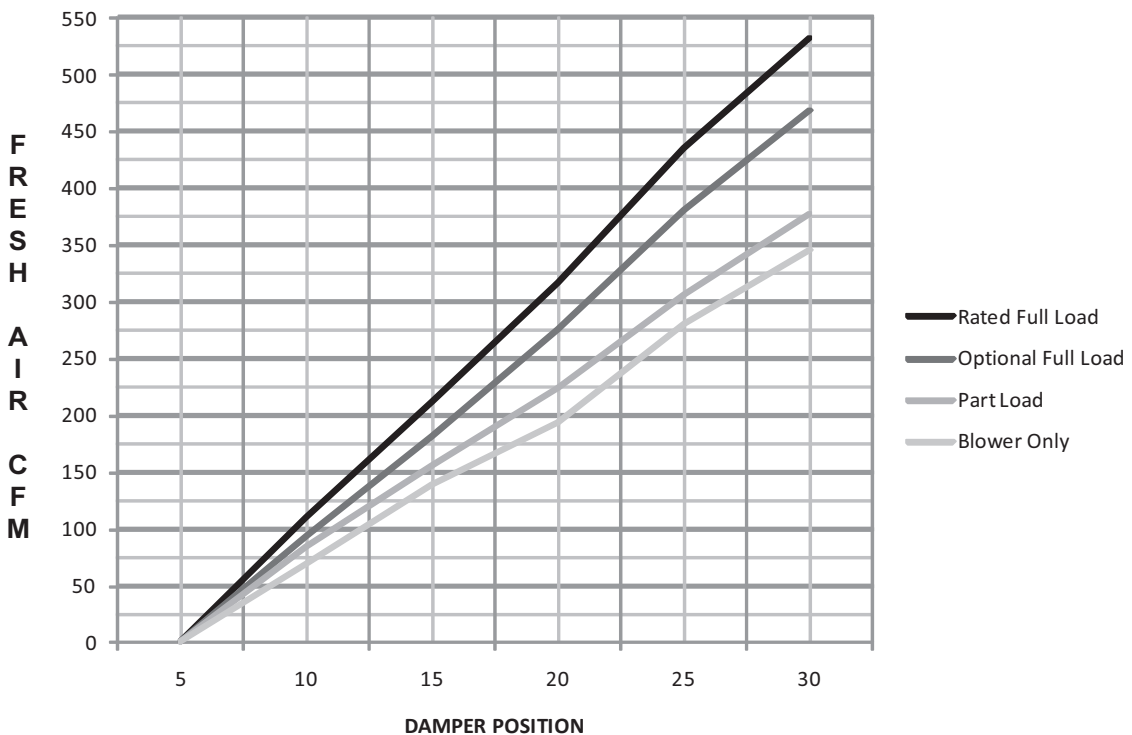

QW4S CRV AIRFLOW VS. DAMPER POSITION

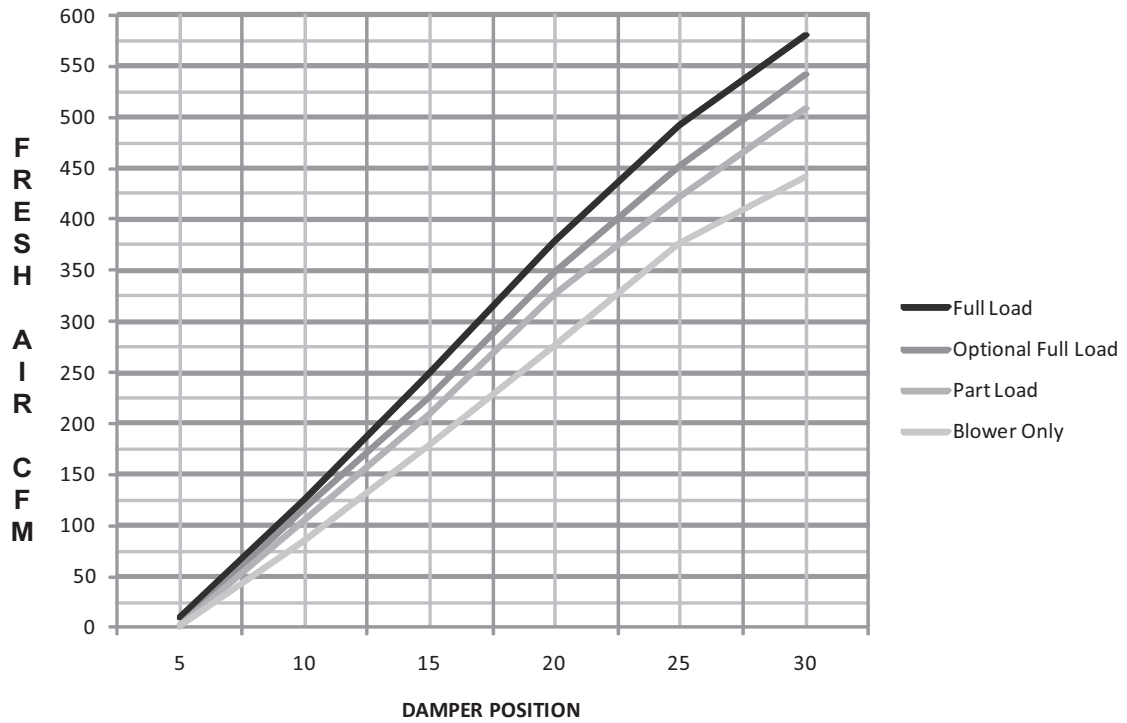

QW5S CRV AIRFLOW VS. DAMPER POSITION

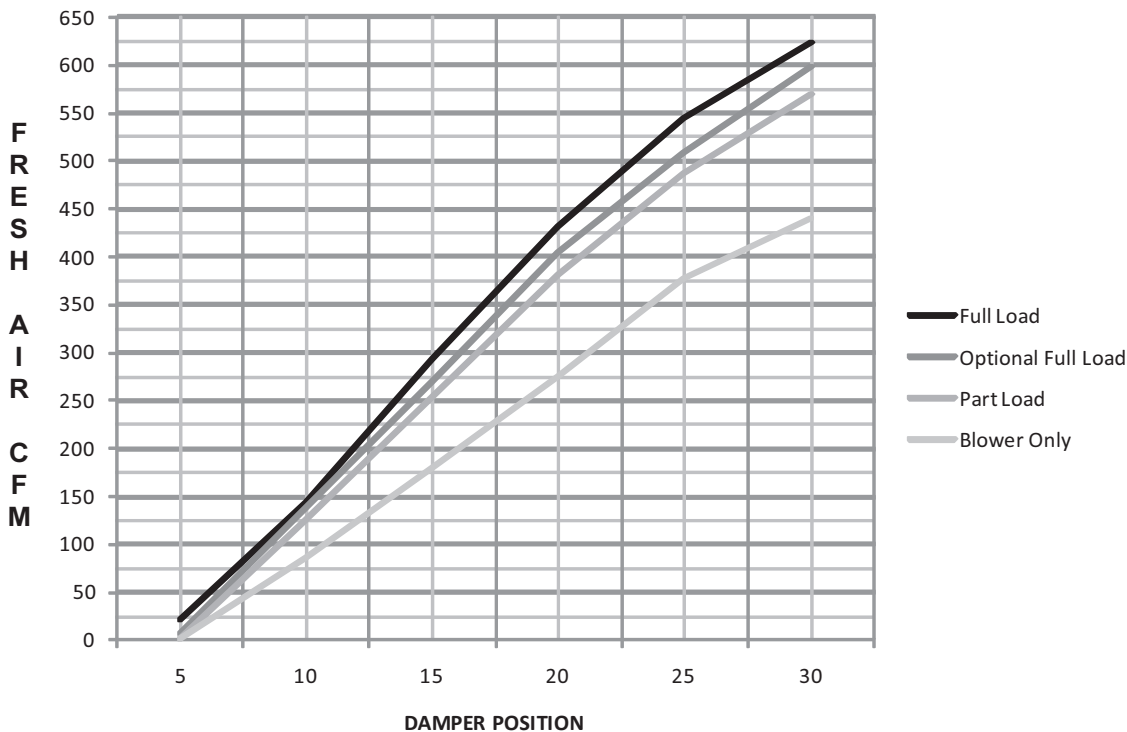

Energy Recovery Ventilator Performance Tables

SUMMER COOLING PERFORMANCE (INDOOR DESIGN CONDITIONS 75°DB/62°WB)

Ambient O.D.	VENTILATION RATE 450 CFM 65% EFFICIENCY							VENTILATION RATE 375 CFM 66% EFFICIENCY							VENTILATION RATE 300 CFM 67% EFFICIENCY						
	DB/WB	F	VLT	VLS	VLL	HRT	HRS	HRL	VLT	VLS	VLL	HRT	HRS	HRL	VLT	VLS	VLL	HRT	HRS	HRL	
105	75		21465	14580	6884	13952	9477	4475	17887	12150	5737	11805	8018	3786	14310	9720	4590	9587	6512	3075	
	70		14580	14580	0	9477	9477	0	12150	12150	0	8018	8018	0	9720	9720	0	6512	6512	0	
	65		14580	14580	0	9477	9477	0	12150	12150	0	8018	8018	0	9720	9720	0	6512	6512	0	
100	80		31590	12150	19440	20533	7897	12635	26325	10125	16200	17374	6682	10692	21060	8100	12960	14110	5427	8683	
	75		21465	12150	9314	13952	7897	6054	17887	10125	7762	11805	6682	5123	14310	8100	6210	9587	5427	4160	
	70		12352	12150	202	8029	7897	131	10293	10125	168	6793	6682	111	8235	8100	135	5517	5427	90	
	65		12150	12150	0	7897	7897	0	10125	10125	0	6682	6682	0	8100	8100	0	5427	5427	0	
	60		12150	12150	0	7897	7897	0	10125	10125	0	6682	6682	0	8100	8100	0	5427	5427	0	
95	80		31590	9720	21870	20533	6318	14215	26325	8100	18225	17374	5345	12028	21060	6480	14580	14110	4341	9768	
	75		21465	9720	11744	13952	6318	7634	17887	8100	9787	11805	5345	6459	14310	6480	7830	9587	4341	5246	
	70		12352	9720	2632	8029	6318	1711	10293	8100	2193	6793	5345	1447	8235	6480	1755	5517	4341	1175	
	65		9720	9720	0	6318	6318	0	8100	8100	0	5345	5345	0	6480	6480	0	4341	4341	0	
	60		9720	9720	0	6318	6318	0	8100	8100	0	5345	5345	0	6480	6480	0	4341	4341	0	
90	80		31590	7290	24300	20533	4738	15794	26325	6075	20250	17374	4009	13365	21060	4860	16200	14110	3256	10854	
	75		21465	7290	14175	13952	4738	9213	17887	6075	11812	11805	4009	7796	14310	4860	9450	9587	3256	6331	
	70		12352	7290	5062	8029	4738	3290	10293	6075	4218	6793	4009	2784	8235	4860	3375	5517	3256	2261	
	65		7290	7290	0	4738	4738	0	6075	6075	0	4009	4009	0	4860	4860	0	3256	3256	0	
	60		7290	7290	0	4738	4738	0	6075	6075	0	4009	4009	0	4860	4860	0	3256	3256	0	
85	80		31590	4860	26730	20533	3159	17374	26325	4050	22275	17374	2672	14701	21060	3240	17820	14110	2170	11939	
	75		21465	4860	16605	13952	3159	10793	17887	4050	13837	11805	2672	9132	14310	3240	11070	9587	2170	7416	
	70		12352	4860	7492	8029	3159	4870	10293	4050	6243	6793	2672	4120	8235	3240	4995	5517	2170	3346	
	65		4860	4860	0	3159	3159	0	4050	4050	0	2672	2672	0	3240	3240	0	2170	2170	0	
	60		4860	4860	0	3159	3159	0	4050	4050	0	2672	2672	0	3240	3240	0	2170	2170	0	
80	75		21465	2430	19035	13952	1579	12372	17887	2025	15862	11805	1336	10469	14310	1620	12690	9587	1085	8502	
	70		12352	2430	9922	8029	1579	6449	10293	2025	8268	6793	1336	5457	8235	1620	6615	5517	1085	4432	
	65		4252	2430	1822	2764	1579	1184	3543	2025	1518	2338	1336	1002	2835	1620	1215	1899	1085	814	
	60		2430	2430	0	1579	1579	0	2025	2025	0	1336	1336	0	1620	1620	0	1085	1085	0	
75	70		12352	0	12352	8029	0	8029	10293	0	10293	6793	0	6793	8235	0	8235	5517	0	5517	
	65		4252	0	4252	2764	0	2764	3543	0	3543	2338	0	2338	2835	0	2835	1899	0	1899	
	60		0	0	0	0	0	0	0	0	0	0	0	0	0	0	0	0	0	0	

WINTER HEATING PERFORMANCE (INDOOR DESIGN CONDITIONS 70°F DB)

Ambient O.D.	VENTILATION RATE								
	450 CFM 80% EFFICIENCY			375 CFM 81% EFFICIENCY			300 CFM 82% EFFICIENCY		
DB/°F	VLT	HRS	VLS	VLT	HRS	VLS	VLT	HRS	VLS
65	2430	1944	486	2025	1640	385	1620	1328	292
60	4860	3888	972	4050	3280	770	3240	2656	583
55	7290	5832	1458	6075	4920	1154	4860	3985	875
50	9720	7776	1944	8100	6561	1539	6480	5313	1166
45	12150	9720	2430	10125	8201	1924	8100	6642	1458
40	14580	11664	2916	12150	9841	2309	9720	7970	1750
35	17010	13608	3402	14175	11481	2693	11340	9298	2041
30	19440	15552	3888	16200	13122	3078	12960	10627	2333
25	21870	17496	4374	18225	14762	3463	14580	11955	2624
20	24300	19440	4860	20250	16402	3848	16200	13284	2916
15	26730	21384	5346	22275	18042	4232	17820	14612	3208
10	29160	23328	5832	24300	19683	4617	19440	15941	3499
5	31590	25272	6318	26325	21323	5002	21060	17269	3791
0	34020	27216	6804	28350	22964	5387	22680	18598	4082
-5	36450	29160	7290	30375	24604	5771	24300	19926	4374
-10	38880	31104	7776	32400	26244	6156	25920	21254	4666

NOTE: Sensible performance only is shown for winter application.

LEGEND:

- VLT = Ventilation Load - Total
- VLS = Ventilation Load - Sensible
- VLL = Ventilation Load - Latent
- HRT = Heat Recovery - Total
- HRS = Heat Recovery - Sensible
- HRL = Heat Recovery - Latent
- WVL = Winter Ventilation Load
- WHR = Winter Heat Recovery

Optional Hot Water Coil Performance – Heating Capacity @ 180°F Water & 70°F Return Air

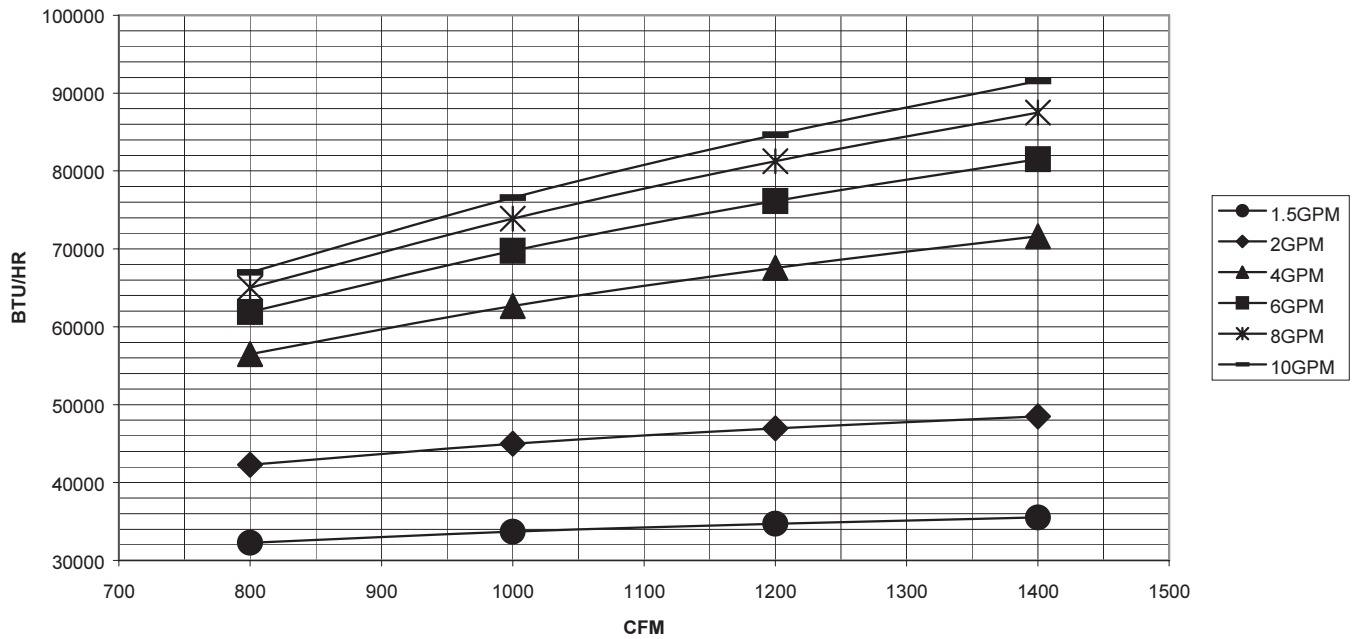

Hot Water Coil Correction Factors

Entering Air Temp (F)	Entering Water Temperature (F)										
	100	110	120	130	140	150	160	170	180	190	200
50	0.455	0.545	0.636	0.727	0.818	0.909	1.000	1.091	1.182	1.273	1.364
55	0.409	0.500	0.591	0.682	0.773	0.864	0.955	1.045	1.136	1.227	1.318
60	0.363	0.455	0.545	0.636	0.727	0.818	0.909	1.000	1.091	1.182	1.273
65	0.318	0.409	0.500	0.591	0.682	0.773	0.864	0.955	1.045	1.136	1.227
70	0.272	0.363	0.455	0.545	0.636	0.727	0.818	0.909	1.000	1.091	1.182
75	0.227	0.318	0.409	0.500	0.591	0.682	0.773	0.864	0.955	1.045	1.136
80	0.182	0.272	0.363	0.455	0.545	0.636	0.727	0.818	0.909	1.000	1.091

Installation Overview of Ventilation Wall Sleeve

Exterior Wall View

NOTE: OPENING DIMENSIONS ARE $\pm .250$

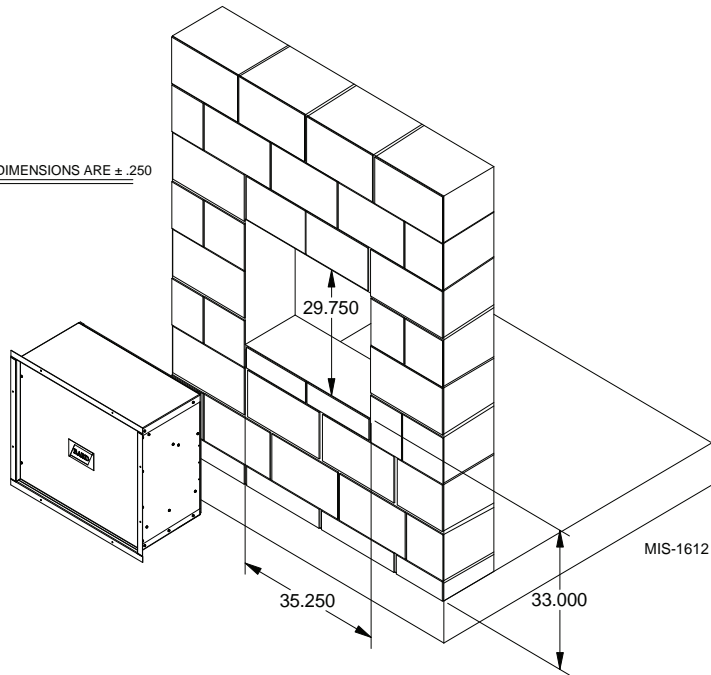

NOTE: Wall opening and wall sleeve required only when one of the ventilation options is utilized. Installations not utilizing any ventilation option can be made in any interior space accessible to electrical supply, water supply system and condensate drain.

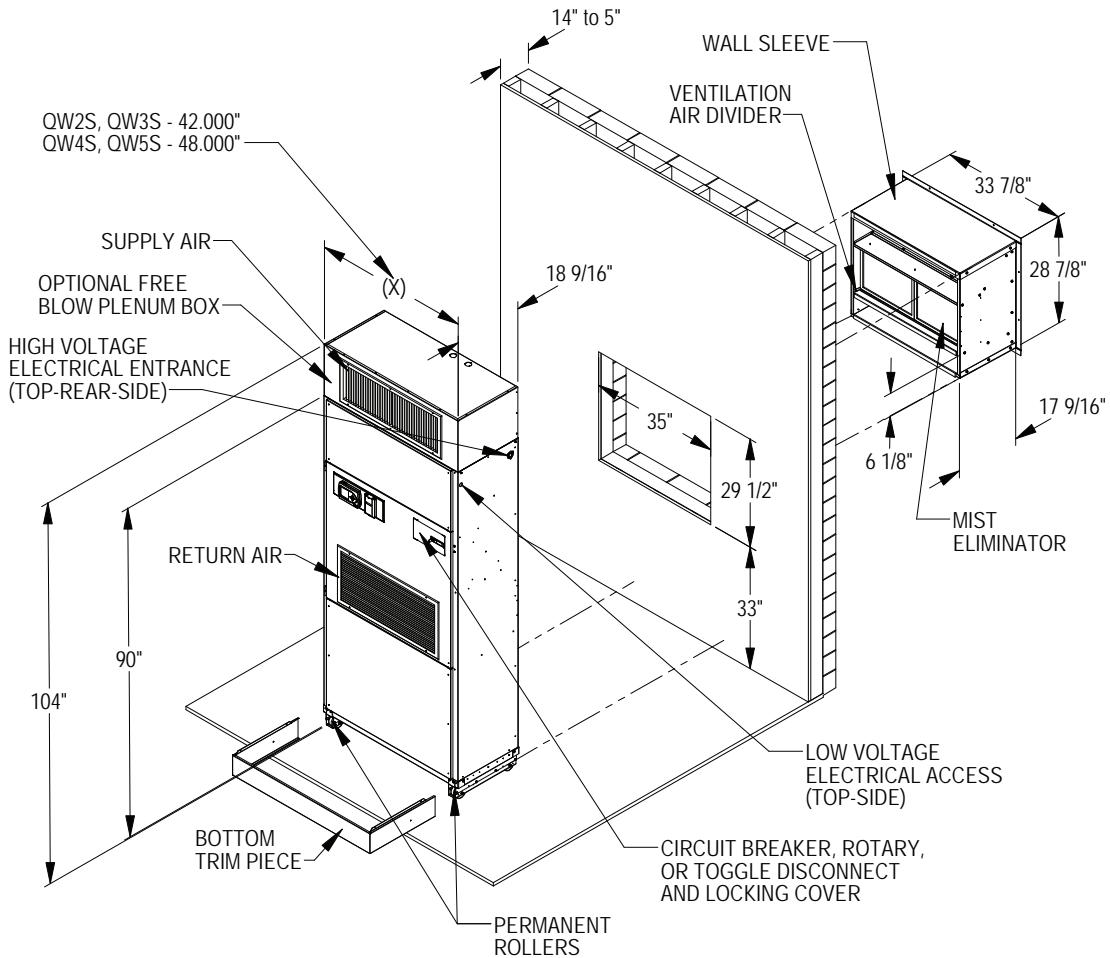

MIS-2739 B

Unit and Wall Sleeve Opening

Supply Duct Connections for Ducted Installations

MODEL	"A"	"B"
QW2S, QW3S	10"	25"
QW4S, QW5S	10"	30"

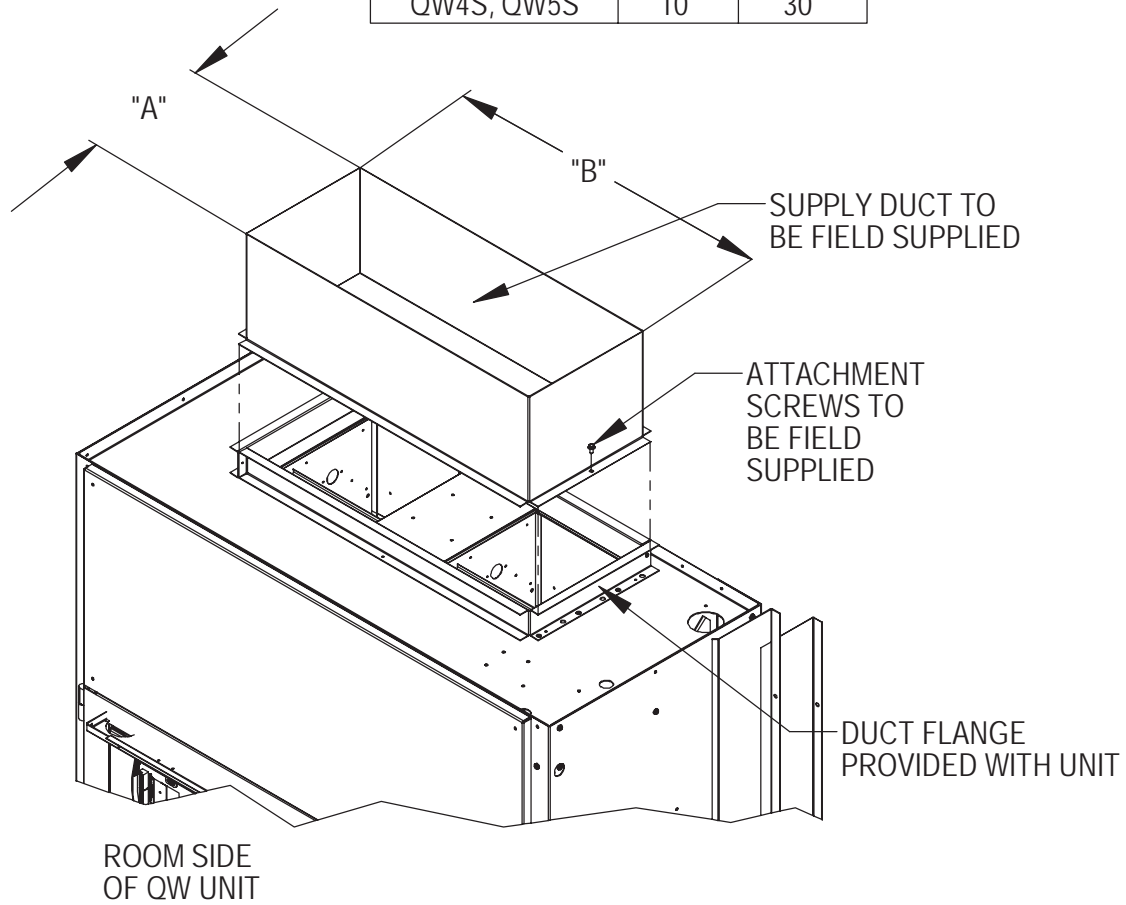

MIS-2742 A

ORS-Series Sound Plenum

The QRS3 - QRS5 Series Sound Plenum has been designed for use with QW*S units. Installation is quick and easy with removal/replacement of six existing screws from the unit cabinet. Once installed the sound plenum enhances the current quiet operation of the Q-TEC Series units, and the hinged door with cam locks (one lockable) provides easy access to the basic Q-TEC system. Model selection is based on equipment cabinet size and finish.

Sound Plenum Part Number	Plenum Finish	Compatible with Equipment Selection
QRS3-X QRS3-4 QRS3-V	Painted Steel - Beige Painted Steel - Buckeye Gray Texture Vinyl ①	QW2S & QW3S
QRS5-X QRS5-4 QRS5-V	Painted Steel - Beige Painted Steel - Buckeye Gray Texture Vinyl ①	QW4S & QW5S

① Front Panels Slate Finish; Side Panels Gray Paint.

UNIT	DIM. "A"
QRS3	42"
QRS5	48"

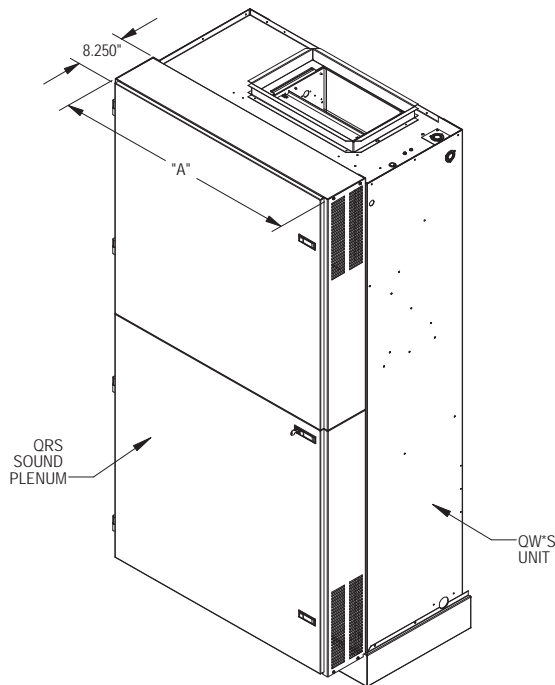

Features:

- Compatible with new or existing QWS units.
- Removable cam latch hinged doors, with center latch lockable.
- Easy unit service design.
- Sound absorbing insulation.
- Reduces equipment operating levels and general muffling of basic unit operation. Actual sound reduction may vary depending upon site variables.

MIS-2794

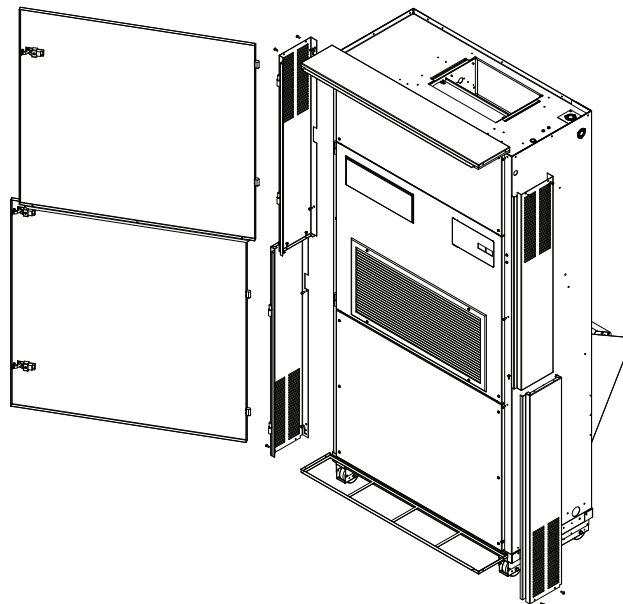

MIS-2267

QRASP – Series Return Air Sound Plenum

The QRASP3 - QRASP5 Series Sound Plenum has been designed for use with sound absorbing side panels. It is similar in design to the QSP Sound Plenum, but also incorporates additional sound attenuation panels on both sides as shown. Installation is quick and easy with removal/replacement of six existing screws from the unit cabinet. Once installed the sound plenum enhances the current quiet operation of the Q-TEC Series units, and the hinged door with cam locks (one lockable) provides easy access to the basic Q-TEC system. Model selection is based on equipment cabinet size and finish.

Sound Plenum Part Number	Plenum Finish	Compatible with Equipment Selection
QRASP3-X QRASP3-4 QRASP3-V	Painted Steel - Beige Painted Steel - Buckeye Gray Texture Vinyl ①	QW2S & QW3S
QRASP5-X QRASP5-4 QRASP5-V	Painted Steel - Beige Painted Steel - Buckeye Gray Texture Vinyl ①	QW4S & QW5S

① Front Panels Slate Finish; Side Panels Gray Paint.

Features:

- Compatible with new or existing QW*S units.
- Removable cam latch hinged doors, with center latch lockable.
- Easy unit service design.
- Incorporates additional sound absorbing side panels.
- Sound absorbing insulation.
- Reduces equipment operating levels and general muffling of basic unit operation. Actual sound reduction may vary depending upon site variables.

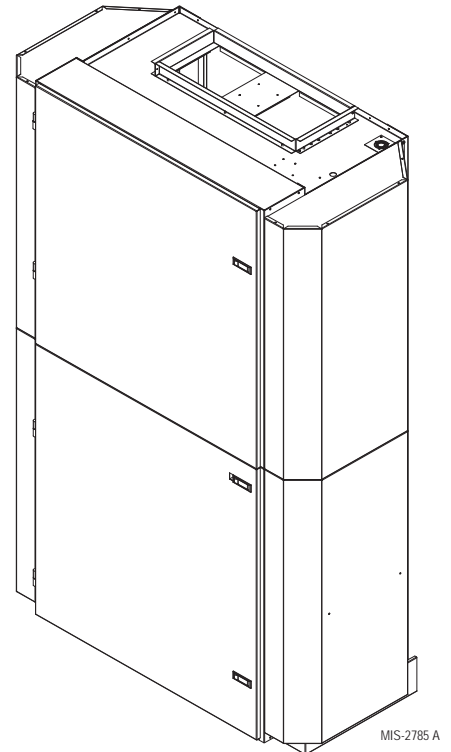

UNIT	DIM A
QRASP3	55 13/16"
QRASP5	61 13/16"

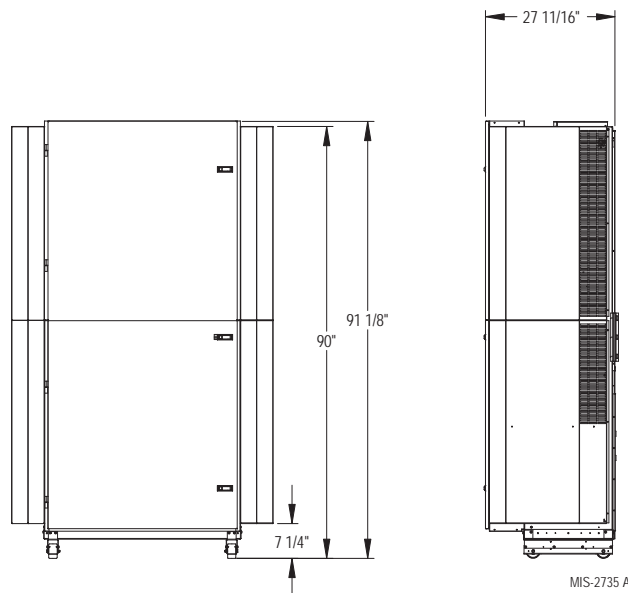
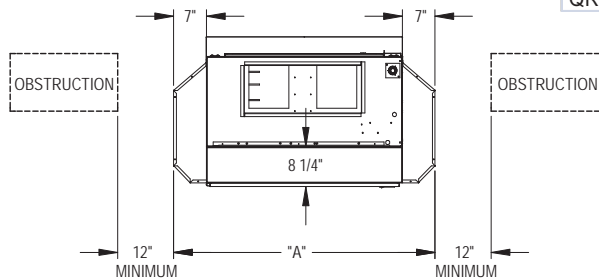

Bard QW2S2 Series Q-TEC Sound Data Matrix (dBA @ 10 feet)

Bard	Duct Free										Ducted																		
	QPBS42					QPBS42					Duct Free Silencer					Ducted					Ducted								
	Return Grille					QRS Plenum					QRS Plenum					Return Grille					QRS Plenum					QRS Plenum			
	ERV Off	300 CFM	375 CFM	450 CFM	ERV Off	300 CFM	375 CFM	450 CFM	ERV Off	300 CFM	375 CFM	450 CFM	ERV Off	300 CFM	375 CFM	450 CFM	ERV Off	300 CFM	375 CFM	450 CFM	ERV Off	300 CFM	375 CFM	450 CFM	ERV Off	300 CFM	375 CFM	450 CFM	
Supply Air Treatment																													
Return Air Treatment																													
Vent Option CNV																													
Ventilation Only																													
Port Load																													
Full Load																													
Integrated dBA																													
Sound Power																													
Outdoor @ 10 Feet																													
Vent Option ERV																													
Blower Only																													
Port Load																													
Full Load																													
Integrated dBA																													
Sound Power																													
Outdoor @ 10 Feet																													

Results Referenced Were Recorded In The Bard Manufacturing Company, Inc. Sound Lab Facility
 Actual Field Application Results May Vary With Classroom Design and Construction Methods
 2/17/2013

Bard QW2S2 Series Q-TEC Sound Data Matrix (dBA @ 5 feet)

Bard	Duct Free										Ducted																		
	QPBS42					QPBS42					Duct Free Silencer					Ducted					Ducted								
	Return Grille					QRS Plenum					QRS Plenum					Return Grille					QRS Plenum					QRS Plenum			
	ERV Off	300 CFM	375 CFM	450 CFM	ERV Off	300 CFM	375 CFM	450 CFM	ERV Off	300 CFM	375 CFM	450 CFM	ERV Off	300 CFM	375 CFM	450 CFM	ERV Off	300 CFM	375 CFM	450 CFM	ERV Off	300 CFM	375 CFM	450 CFM	ERV Off	300 CFM	375 CFM	450 CFM	
Supply Air Treatment																													
Return Air Treatment																													
Vent Option CNV																													
Ventilation Only																													
Port Load																													
Full Load																													
Integrated dBA																													
Sound Power																													
Outdoor @ 10 Feet																													
Vent Option ERV																													
Blower Only																													
Port Load																													
Full Load																													
Integrated dBA																													
Sound Power																													
Outdoor @ 10 Feet																													

Results Referenced Were Recorded In The Bard Manufacturing Company, Inc. Sound Lab Facility
 Actual Field Application Results May Vary With Classroom Design and Construction Methods
 11/14/2013

Bard QW3S2 Series Q-TEC Sound Data Matrix (dBA @ 10 feet)

Bard	Duct Free										Ducted															
	QPBS42					QPBS42					Return Grille					Return Grille					Ducted					
	Return Grille					QRS Plenum					QRASPS Plenum					QRASPS Plenum					Ducted					
	ERV Off	300 CFM	375 CFM	450 CFM	450 CFM	ERV Off	300 CFM	375 CFM	450 CFM	450 CFM	ERV Off	300 CFM	375 CFM	450 CFM	450 CFM	ERV Off	300 CFM	375 CFM	450 CFM	450 CFM	ERV Off	300 CFM	375 CFM	450 CFM	450 CFM	
Supply Air Treatment																										
Return Air Treatment																										
Vent Option CRV																										
Ventilation Only																										
Part Load																										
Full Load																										
Integrated dBA																										
Sound Power Full Load																										
Outdoor @ 10 Feet																										
Vent Option CRV																										
Blower Only																										
Part Load																										
Full Load																										
Integrated dBA																										
Sound Power Full Load																										
Outdoor @ 10 Feet																										

1 Integrated values calculated per ANSI/ASHRAE 51.2-2009 Part 2, Section 5.2.2.1, Table 2 Triple Mode Type 3 HVAC System Duty Cycles: Ventilation 58%, Part Load 25%, Full Load 17%
 2 Integrated Sound Values are also applicable for use in learning spaces for CHPS and LEED schools; EQ Prerequisite 3 - Minimum Acoustical Performance, OPTION 1. Using methods prescribed in ANSI S12.60, classroom must achieve a maximum background noise level of 45 dBA.
 3 All data recorded at rated CFM per Bard product specifications.
 Actual Field Application Results May Vary With Classroom Design and Construction Methods
 10/28/2013

Bard QW3S2 Series Q-TEC Sound Data Matrix (dBA @ 5 feet)

Bard	Duct Free										Ducted															
	QPBS42					QPBS42					Return Grille					Return Grille					Ducted					
	Return Grille					QRS Plenum					QRASPS Plenum					QRASPS Plenum					Ducted					
	ERV Off	300 CFM	375 CFM	450 CFM	450 CFM	ERV Off	300 CFM	375 CFM	450 CFM	450 CFM	ERV Off	300 CFM	375 CFM	450 CFM	450 CFM	ERV Off	300 CFM	375 CFM	450 CFM	450 CFM	ERV Off	300 CFM	375 CFM	450 CFM	450 CFM	
Supply Air Treatment																										
Return Air Treatment																										
Vent Option CRV																										
Ventilation Only																										
Part Load																										
Full Load																										
Integrated dBA																										
Sound Power Full Load																										
Outdoor @ 10 Feet																										
Vent Option CRV																										
Blower Only																										
Part Load																										
Full Load																										
Integrated dBA																										
Sound Power Full Load																										
Outdoor @ 10 Feet																										

1 Integrated values calculated per ANSI/ASHRAE 51.2-2009 Part 2, Section 5.2.2.1, Table 2 Triple Mode Type 3 HVAC System Duty Cycles: Ventilation 58%, Part Load 25%, Full Load 17%
 2 Integrated Sound Values are also applicable for use in learning spaces for CHPS and LEED schools; EQ Prerequisite 3 - Minimum Acoustical Performance, OPTION 1. Using methods prescribed in ANSI S12.60, classroom must achieve a maximum background noise level of 45 dBA.
 3 All data recorded at rated CFM per Bard product specifications.
 Actual Field Application Results May Vary With Classroom Design and Construction Methods
 10/28/2013

Bard QW5S2 Series Q-TEC Sound Data Matrix (dBA @ 10 feet)

Bard	Duct Free										Ducted																							
	QPBS48					QPBS48					Return Grille					Return Grille					QRS Plenum					QRS Plenum								
	ERV Off	300 CFM	375 CFM	450 CFM	450 CFM	ERV Off	300 CFM	375 CFM	450 CFM	450 CFM	ERV Off	300 CFM	375 CFM	450 CFM	450 CFM	ERV Off	300 CFM	375 CFM	450 CFM	450 CFM	ERV Off	300 CFM	375 CFM	450 CFM	450 CFM									
Supply Air Treatment	42.0	43.1	44.0	48.1	48.1	40.3	40.8	41.2	44.7	40.3	40.8	41.2	44.7	40.3	38.0	38.5	39.5	42.8	45.0 CFM	37.8	42.2	45.7	50.2	36.1	38.1	40.3	45.7	34.0	35.2	36.6	40.0			
Return Air Treatment	47.2	47.4	47.9	49.9	46.8	45.1	45.0	45.6	46.8	43.8	44.1	44.4	46.4	46.4	43.4	42.9	42.8	45.0	45.0	43.9	44.9	47.2	51.6	42.7	43.1	43.7	46.9	39.5	40.0	40.7	42.4			
Vent Option CRV	47.9	48.3	48.5	50.4	47.5	45.9	46.2	46.4	47.5	44.9	45.0	45.5	46.6	46.6	44.1	44.3	44.3	45.6	45.6	46.1	46.9	48.6	52.0	45.0	45.2	45.1	47.7	41.9	42.2	42.4	43.8			
Ventilation Only	45.2	45.7	46.2	49.1	45.9	43.2	43.4	43.8	45.9	41.9	42.5	42.9	45.3	45.3	41.3	41.3	41.6	44.0	44.0	42.2	44.1	46.7	50.9	40.9	41.6	42.4	46.4	38.0	38.6	39.3	41.5			
Part Load																																		
Full Load																																		
Integrated dBA																																		
Sound Power Full Load																																		
Outdoor @ 10 Feet	39.6																																	
Vent Option ERV																																		
Blower Only																																		
Part Load																																		
Full Load																																		
Integrated dBA																																		
Sound Power Full Load																																		
Outdoor @ 10 Feet	53.8																																	

1. Integrated values calculated per ANSI/ASHRAE 91.2-2009/Part 2, Section 5.2.2.1, Table 2 Triple Mode Type 3 HVAC System Duty Cycles: Ventilation 80%, Part Load 25%, Full Load 17%.
 2. Integrated Sound Values are also applicable for use in learning spaces for CHPS and LEED schools; EQ Prerequisite 3 - Minimum Acoustical Performance, OPTION 1. Using methods prescribed in ANSI S12.60, classroom must achieve a maximum background noise level of 45 dBA.
 3. All data recorded at rated CFM per Bard product specifications.
 Actual Field Application Results May Vary With Classroom Design and Construction Methods.
 9/27/2013

Bard QW5S2 Series Q-TEC Sound Data Matrix (dBA @ 5 feet)

Bard	Duct Free										Ducted																							
	QPBS48					QPBS48					Return Grille					Return Grille					QRS Plenum					QRS Plenum								
	ERV Off	300 CFM	375 CFM	450 CFM	450 CFM	ERV Off	300 CFM	375 CFM	450 CFM	450 CFM	ERV Off	300 CFM	375 CFM	450 CFM	450 CFM	ERV Off	300 CFM	375 CFM	450 CFM	450 CFM	ERV Off	300 CFM	375 CFM	450 CFM	450 CFM									
Supply Air Treatment	42.5	44.7	46.4	50.1	48.1	41.6	42.1	42.7	48.1	41.6	42.1	42.7	48.1	41.6	38.6	40.0	40.4	45.1	45.0 CFM	39.8	45.7	50.0	53.9	37.5	39.6	41.8	45.9	34.9	36.2	37.8	41.9			
Return Air Treatment	48.6	49.1	49.5	51.6	48.7	46.2	46.4	46.6	48.7	45.9	46.2	46.1	48.3	48.3	44.8	44.4	44.9	46.7	46.7	45.3	47.8	50.6	54.2	43.8	44.5	45.1	48.3	40.7	41.5	41.8	43.8			
Vent Option CRV	49.3	49.5	50.4	52.1	48.8	47.2	47.4	47.4	48.8	46.7	47.0	47.1	48.6	48.6	45.8	45.9	45.9	47.2	47.2	48.4	49.9	52.1	54.7	45.6	45.9	46.6	49.0	43.4	43.6	43.8	44.9			
Ventilation Only	46.3	47.2	48.2	50.9	48.4	44.4	44.7	45.0	48.4	43.6	44.2	44.4	47.1	47.1	42.6	42.9	43.2	46.0	46.0	44.1	47.3	50.6	54.1	41.9	42.8	43.9	47.2	39.3	39.9	40.6	43.1			
Part Load																																		
Full Load																																		
Integrated dBA																																		
Sound Power Full Load																																		
Outdoor @ 10 Feet	41.0																																	
Vent Option ERV																																		
Blower Only																																		
Part Load																																		
Full Load																																		
Integrated dBA																																		
Sound Power Full Load																																		
Outdoor @ 10 Feet	53.8																																	

1. Integrated values calculated per ANSI/ASHRAE 91.2-2009/Part 2, Section 5.2.2.1, Table 2 Triple Mode Type 3 HVAC System Duty Cycles: Ventilation 80%, Part Load 25%, Full Load 17%.
 2. Integrated Sound Values are also applicable for use in learning spaces for CHPS and LEED schools; EQ Prerequisite 3 - Minimum Acoustical Performance, OPTION 1. Using methods prescribed in ANSI S12.60, classroom must achieve a maximum background noise level of 45 dBA.
 3. All data recorded at rated CFM per Bard product specifications.
 Actual Field Application Results May Vary With Classroom Design and Construction Methods.
 9/27/2013

Optional Accessories — Must be Used for Each Installation with Ventilation Options

Ventilation Wall Sleeves:

QWVS42 Ventilation wall sleeve for walls up to 14 inches thick. **NOTE:** Unless they are to be field-supplied, side trim kit must be ordered for all installations.

Ventilation Louvers:

- QLW-10 Standard Clear Painted Enamel Finish for vent option
- QLW-20 Standard Medium Bronze Painted Enamel Finish for vent option
- QLW-30 Standard Dark Bronze Painted Enamel Finish for vent option
- QLW-* Optional Louver Finishes available (See Form S3508)

Contact your Bard Sales Representative for Custom Finish Louver information

Side Trim Kits — Required for All Installations Unless Field-Supplied

NOTE: The following accessory items must be selected so the finish (color) is matched to the QWS model that they will be used with.

Side Trim Extension Kits:

Model	Color	Model	Color	Model	Color	Model	Color	Space from back of unit to wall	Unit Compatibility
QSTX-V-6	Platinum Vinyl	QSTX-4-6	Gray Paint	QSTX-X-6	Beige Paint	QSTX-1-6	White Paint	4" to 6"	All
QSTX-V-8	Platinum Vinyl	QSTX-4-8	Gray Paint	QSTX-X-8	Beige Paint	QSTX-1-8	White Paint	6" to 8"	All
QSTX-V-10	Platinum Vinyl	QSTX-4-10	Gray Paint	QSTX-X-10	Beige Paint	QSTX-1-10	White Paint	8" to 10"	All
QSTX-V-12	Platinum Vinyl	QSTX-4-12	Gray Paint	QSTX-X-12	Beige Paint	QSTX-1-12	White Paint	10" to 12"	All

Optional Accessories — Additional Items as Determined by Job Specifications

Duct-Free Plenum Boxes:

Model	Color	Model	Color	Model	Color	Space from back of unit to wall	Unit Compatibility		
QPB42-V	Platinum Vinyl	QPB42-4	Gray Paint	QPB42-X	Beige Paint	QPB42-1	White Paint	Front supply, 4-way deflection grille	QW2S, QW3S
QPBS42-V	Platinum Vinyl	QPBS42-4	Gray Paint	QPBS42-X	Beige Paint	QPBS42-1	White Paint	Same as QPB42, plus 2-way deflection grille on each side	QW2S, QW3S
QPBS42-V-8	Platinum Vinyl	QPBS42-4-8	Gray Paint	QPBS42-X-8	Beige Paint	QPBS42-1-8	White Paint	Same as QPBS42 and 8" Height ⊕	QW2S, QW3S
QPB48-V	Platinum Vinyl	QPB48-4	Gray Paint	QPB48-X	Beige Paint	QPB48-1	White Paint	Front supply, 4-way deflection grille	QW4S, QW5S
QPBS48-V	Platinum Vinyl	QPBS48-4	Gray Paint	QPBS48-X	Beige Paint	QPBS48-1	White Paint	Same as QPB48, plus 2-way deflection grille on each side	QW4S, QW5S
QPBS48-V-8	Platinum Vinyl	QPBS48-4-8	Gray Paint	QPBS48-X-8	Beige Paint	QPBS48-1-8	White Paint	Same as QPBS48 and 8" Height ⊕	QW4S, QW5S

Top Fill Systems for Finishing Plenum Boxes to Ceilings:

QPBX42-9-V	Platinum Vinyl	QPBX42-9-4	Gray Paint	QPBX42-9-X	Beige Paint	QPBX42-9-1	White Paint	Use with QPB42 or QPBS42 (adjusts to ceilings up to 9'9")	QW2S, QW3S
QPBX42-10-V	Platinum Vinyl	QPBX42-10-4	Gray Paint	QPBX42-10-X	Beige Paint	QPBX42-10-1	White Paint	Use with QPB42 or QPBS42 (adjusts to ceilings up to 10'5")	QW2S, QW3S
QPBX48-9-V	Platinum Vinyl	QPBX48-9-4	Gray Paint	QPBX48-9-X	Beige Paint	QPBX48-9-1	White Paint	Use with QPB48 or QPBS48 (adjusts to ceilings up to 9'9")	QW4S, QW5S
QPBX48-10-V	Platinum Vinyl	QPBX48-10-4	Gray Paint	QPBX48-10-X	Beige Paint	QPBX48-10-1	White Paint	Use with QPB48 or QPBS48 (adjusts to ceilings up to 10'5")	QW4S, QW5S

Cabinet Extensions for Ducted Applications:

Model	Color	Model	Color	Model	Color	Space from back of unit to wall	Unit Compatibility		
QCX10A-V	Platinum Vinyl	QCX10A-4	Gray Paint	QCX10A-X	Beige Paint	QCX10A-1	White Paint	20" height (adjusts for ceilings up to 9'7"; add QPBX42-9 for 9'7" to 10'3" finished ceiling heights)	QW2S, QW3S
QCX15A-V	Platinum Vinyl	QCX15A-4	Gray Paint	QCX15A-X	Beige Paint	QCX15A-1	White Paint	20" height (adjusts for ceilings up to 9'7"; add QPBX48-9 for 9'7" to 10'3" finished ceiling heights)	QW4S, QW5S

Hot Water Coils with Plenum Boxes:

Model	Color	Model	Color	Model	Color	Space from back of unit to wall	Unit Compatibility		
QPBHW42-F-V	Platinum Vinyl	QPBHW42-F-4	Gray Paint	QPBHW42-F-X	Beige Paint	QPBHW42-F-1	White Paint	Free blow plenum box	QW2S, QW3S
QPBHW48-F-V	Platinum Vinyl	QPBHW48-F-4	Gray Paint	QPBHW48-F-X	Beige Paint	QPBHW48-F-1	White Paint	Free blow plenum box	QW4S, QW5S
QPBHW42-D-V	Platinum Vinyl	QPBHW42-D-4	Gray Paint	QPBHW42-D-X	Beige Paint	QPBHW42-D-1	White Paint	Ducted plenum box	QW2S, QW3S
QPBHW48-D-V	Platinum Vinyl	QPBHW48-D-4	Gray Paint	QPBHW48-D-X	Beige Paint	QPBHW48-D-1	White Paint	Ducted plenum box	QW4S, QW5S

NOTE: The same top fill system and cabinet extensions can be used with hot water coil plenum boxes as with standard plenum boxes.

⊕ 8" Plenum Box height may affect sound level of supply air and unit.

WATER CONNECTION OPTIONS

Female National Pipe Thread (NPT) Connections (Piping Option "P")

1" Female National Pipe Thread (NPT) copper fitting connections at inlet and outlet of co-axial water coil. No internal pump options available with piping option "P".

Double O-Ring Water Connections (Piping Option "X")

IMPORTANT NOTE: Water coils can be equipped with male half of double O-ring fittings and a mating half must be used. No other type of fitting will mate up. The DORFC Flow Centers also have double O-ring connections on both heat pump and loop sides of flow center.

Depending upon pump and piping options ordered, additional double O-ring fittings and hose may be required. Fittings are available for threaded, barbed, soldered and fusion connections.



Elbow, 1" MPT X Double O-ring with 1/4" Port and Pressure/Temperature Test Plugs
DORMP1-90



1" MPT X Double O-ring
DORMP1-S



1" FPT X Double O-ring
DORFP1-S

Elbow, 1" MPT X Double O-ring with 1/4" Port and 1/4" Brass Pipe Plugs
DORMP1-90P



Elbow, 1" Hose Barb X Double O-ring with 1/4" Port and Pressure/Temperature Test Plugs
DORB1-90-4HC



1" Hose Barb X Double O-ring
DORB1-S-4HC



1-1/4" Socket Fusion X Double O-ring
DORF125-S



1" Copper Sweat X Double O-ring with 1/4" FPT Port & Pressure/Temperature Test Plugs
DORS1-S

Elbow, 1" Hose Barb X Double O-ring with 1/4" Port and 1/4" Brass Pipe Plugs
DORB1-90P-4HC

Individual Double O-Ring Fitting Packs (Qty 2 per pack)

DORMP1-90	(2) 1" MPT 90° double o-ring elbows with 1/4" FPT ports and 8603-026 pressure/temperature test plugs
DORMP1-90P	(2) 1" MPT 90° double o-ring elbows with 1/4" FPT ports and 1/4" brass pipe plugs
DORMP1-S	(2) 1" MPT straight double o-ring fittings
DORFP1-S	(2) 1" FPT straight double o-ring fittings
DORB1-90-4HC	(2) 1" barbed 90° double o-ring elbows with 1/4" FPT ports, 8603-026 pressure/temperature test plugs and (4) SS 1" hose clamps
DORB1-90P-4HC	(2) 1" barbed 90° double o-ring elbows with 1/4" FPT ports, 1/4" brass pipe plugs and (4) SS 1" hose clamps
DORB1-S-4HC	(2) 1" barbed straight double o-ring fittings with (4) 1" SS hose clamps
DORF125-S	(2) 1.25" fusion straight double o-ring fittings
DORS1-S	(2) 1" copper sweat straight double o-ring fittings with 1/4" FPT ports and 8603-026 pressure/temperature test plugs

Optional Hose	HK1-25	(1) 25' section of 1" ID 150 PSI hose
----------------------	---------------	--

Flow Centers & Individual Pumps w/Double O-Ring Connections (See Pump Ratings Below)

Pump Option	Pump Model	No. of Pumps	Description	Installation Method
1	DORFC-1	1	Loop Flow Center w/Insulated Cabinet, 230V-60Hz-1Ph, Double O-ring Fittings, UP26-99F Pump, Brass Isolation & Flush Valves Built-In	Can be factory or field installed
2	DORFC-2	2	Loop Flow Center w/Insulated Cabinet, 230V-60Hz-1Ph, Double O-ring Fittings, UP26-99F Pump, Brass Isolation & Flush Valves Built-In	
3	UPS15-42F	1	Pump with Isolation Valves, 230V-60Hz-1Ph, Piped to Rear of Cabinet, Double O-ring Connections	Factory installed only
4	UP26-64F	1	Pump with Isolation Valves, 230V-60Hz-1Ph, Piped to Rear of Cabinet, Double O-ring Connections	
5	UPS26-99FC	1	Pump with Isolation Valves, 230V-60Hz-1Ph, Piped to Rear of Cabinet, Double O-ring Connections	



DORFC-2



UPS26

Flow Center and Individual Pump Accessories

Bard Part Number	Required Quantity	Description	Used With
QWRK	1	Consists of control relay, two 3A circuit breakers, all wiring and all installation parts	Included with factory installed DORFC Flow Centers and UPS Pumps. Order only if field installing any flow center or pump.
QWHK	1	Consists of two 1" x 33" 200 PSIG hoses with SS braided sheathing and fitted with straight double o-ring fittings one end and 90° elbow double o-ring fittings with P/T ports installed on opposite end.	Included with units for factory installed DORFC's. Order only if field installing DORFC.

① This is factory installed if flow center or pump is factory installed.

Loop Pump Modules and Individual Pump Capacities ① ②

For Use with QWS Models ③	Pump Option	Pump Model	No. of Pumps	No. of Speeds	Speed	WATER FLOW in GPM											
						5	6	7	8	9	10	11	12	13	14	15	16
ALL	1	DORFC-1	1	1	Single	29.5	29	28.5	28	27.5	26.5	25.5	24.5	23	22.5	22	21
ALL	2	DORFC-2	2	1	Single	59	58	57	56	55	53	51	49	46	45	44	42
QW2 - 3S	3	UPS15-42F	1	3	High	12.1	11.5	10.7	9.7	8.8	8	—	—	—	—	—	—
					Medium	6.8	5.7	4.5	—	—	—	—	—	—	—	—	—
					Low	—	—	—	—	—	—	—	—	—	—	—	—
QW2 - 3S	4	UP26-64F	1	1	Single	21.5	21	20	19	18	17	16.5	16	15	14	13	12.5
QW3 - 5S	5	UPS26-99FC	1	3	High	29.5	29	28.5	28	27.5	26.5	25.5	24.5	23	22.5	22	21
					Medium	23.5	22.2	21.5	20.3	19.5	18.5	17.8	16.5	15.3	14.3	13.3	12.4
					Low	15.3	13.8	12.4	10.9	9.8	8.4	—	—	—	—	—	—

① Pump output shown in feet head @ GPM at top of columns.

② Refer to Water Coil Pressure Drop table (Page 8) for feet head allowances for basic QW*S complete system. Additional feet head allowance from basic unit to main piping loop must be included and determined by others.

③ Pump options shown can be factory installed in models as shown. Suitability of each must be determined by others based on QWS requirements, plus the loop design requirements designed by others.

Ground Loop Service Accessories for Installations with DORFC Flow Centers

Heat Pump Model	Bard Part Number	Required Quantity	Description
		DORCL1-90	Each
	CLB1-S	Each	(2) 1" straight barbed quick-connect cam-lever female fittings to connect to DORCL1-90 fittings above
	GGK-1	Each	(1) Geo-Gooser w/shut-off valve, 0-100 PSI gauge, garden hose connection, P/T fitting 1/8" probe
	DORGHMT	Each	(2) Double o-ring x male garden hose adapter fitting for loop flow center (to burp/boost loop)



1" Cam Lever Male X Double O-ring DORCL1-90



CLB1-S



Garden Hose Male X O-ring (single) Adapter DORGHMT



GGK-1

QW*S Step Capacity Series Q-TEC Geothermal HP Model Nomenclature

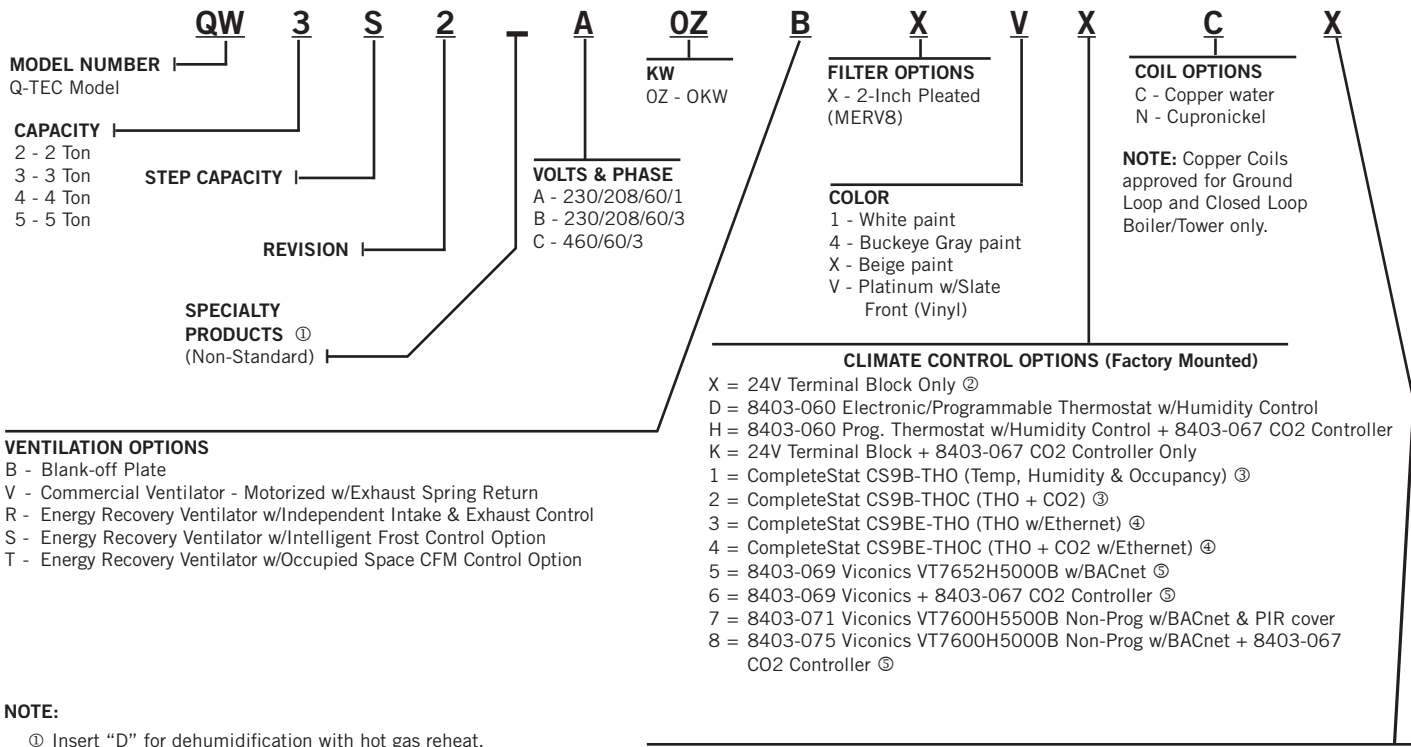

NOTE:

- ① Insert "D" for dehumidification with hot gas reheat. Reference 7960-658 for complete details.
- ② If "X" control option is selected, then thermostat and humidistat, if applicable, or DDC control system must be field supplied.
- ③ CS9B-THO and -THOC are BACnet w/shielded twisted pair wiring.
- ④ CS9BE-THO and -THOC are BACnet w/shielded twisted pair wiring and Ethernet port.
- ⑤ Not available for Dehumidification Models.

FACTORY INSTALLED PUMP & PIPING OPTIONS

- X - None; all pump & water connections field installed, requires field piping to the coaxial water coil using double o-ring fittings, which must be ordered separately.
- P - None; all pump & water connections field installed, requires field piping to the coaxial water coil 1" Female NPT wrought copper fittings.
 - 1 - DORFC-1 double o-ring flow center, single Grundfos UP26-99F pump piped to water coil with 150 PSI reinforced hose
 - 2 - DORFC-2 double o-ring flow center, double Grundfos UP26-99F pump piped to water coil with 150 PSI reinforced hose
 - 3 - Single Grundfos UPS15-42F pump, isolation valves both ends, piped with copper to double o-ring fittings back corners of unit
 - 4 - Single Grundfos UP26-64F pump, isolation valves both ends, piped with copper to double o-ring fittings back corners of unit
 - 5 - Single Grundfos UPS26-99-FC pump, isolation valves both ends, piped with copper to double o-ring fittings back corners of unit

See Pages 23, 24 & 25 for Additional Required and Optional Field Installed Accessories

Optional Field Installed Hard Start Kits for 1-Phase Models ①	
Unit Model	Field Installed Part Number
QW2S2-A only	SK111
QW3S2-A only	SK111
QW4S2-A only	SK118
QW5S2-A only	SK118

① Start Capacitor and potential relay start kit can be used with all -A single phase models only. Increases starting torque 9x. Not used on -B or -C three phase models.

Optional Field Installed Evap. Drain Pan Overflow Kit	
Part Number	Description
8620-219	24VAC 0.4A SPST NC Switch to shutdown compressor. Can be converted to NO action to use for alarm circuit.



Bard Manufacturing Company, Inc.
Bryan, Ohio 43506
www.bardhvac.com

Due to our continuous product improvement policy, all specifications subject to change without notice.

Before purchasing this appliance, read important energy cost and efficiency information available from your retailer.

Form No. S3419 May 2021
Supersedes: S3419-617