



The Wall-Mount™ Step Capacity Gas/Electric - WG*S Series Integrated Part Load Value (IPLV) Efficiency Up to 15.6 BTU/WATT NOx Certified Models

WG3S2, WG4S2, WG5S2 **60HZ**
24,000 to 56,500 BTUH Cooling Capacity
37,000 to 74,000 BTUH Heating Capacity

GREEN REFRIGERANT
R-410A

- **High Efficiency**
- **Low Sound Level**

The Bard Wall-Mount Electric Air Conditioner with gas fired heating is a self contained energy efficient system which is designed to offer maximum indoor comfort at a minimal cost without using valuable indoor floor space or outside ground space. This unit is the ideal product for versatile applications such as: new construction, modular offices, school modernization, portable structures, correctional facilities, retail stores or other commercial applications. Factory or field installed accessories are available to meet specific job requirements.

Engineered Features

Multi-Capacity Two-Stage:

Simple thermostatic control seamlessly stages the compressor and indoor airflow rate between high and low capacity operations without cycling the compressor. This helps to maximize comfort, humidity control, energy efficiency and overall reduction in compressor cycling for improved system life.

Step Capacity Compressor:

Copeland step-capacity (2-stage) scroll compressors are designed for increased efficiency, quieter operation and improved reliability for longer life. Double isolated floating mounting base, compressor sound blanket and discharge muffler for reduced sound level.

R-410A Refrigerant:

Designed with R-410A (HFC) non-ozone depleting refrigerant in compliance with the Montreal protocol and 2010 EPA requirements.

Thermal Expansion Valves:

All models use TXV.

Liquid Line Filter Drier:

Protects system against moisture.

Aluminum Finned Copper Coils:

Grooved tubing and enhanced louvered fin for maximum heat transfer and energy efficiency.

High & Low Pressure Switches are Auto-Reset

Built-in lockout circuit resets from the room thermostat. Provides commercial quality protection to the compressor.

Compressor Control Module:

Standard on all units. Built-in off-delay timer adjustable from 30 seconds to 5 minutes. 2-minute on-delay if power interrupt. 120-second bypass for low pressure control, and both soft and manual lockouts for high and low pressure controls. Alarm output for alarm relay.

Crankcase Heaters:

Factory installed crankcase heaters are standard on all models. This helps to ensure ease of start at low temperatures and improves compressor life.

Phase Rotation Monitor:

Standard on all 3 phase scroll compressors. Protects against reverse rotation if power supply is not properly connected.

Twin Blowers:

Move air quietly. All models feature variable speed blower motors providing automatic airflow adjustment for high static or free blow (non-ducted) operation at a very low sound level. Motor overload protection is standard on all models.

ECM Indoor Blower Motor:

Features a variable speed motor providing super-high efficiency, low sound levels and soft-start capabilities. The motor is self-adjusting to provide the proper airflow rate for the staged capacity, and for higher static pressure in ducted installations without user adjustment or wiring changes.

Ventilation Controller:

Automatically adjusts damper position to maintain the desired ventilation airflow rate up to 480 cfm of fresh air during any operation mode. Fully closes during unoccupied modes. Factory set for 480 cfm. Also, CO₂ sensor ready - just add CO₂ sensor for demand ventilation based on CO₂ level in the space.

Electrical Components:

Are easily accessible for routine inspection and maintenance through a right side, service panel opening. Features a lockable, hinged access cover to the circuit breaker or rotary disconnect switch.

Heat Exchanger:

Heavy duty 18-gauge stainless steel tubular heat exchanger. Mechanically joined construction. Ten-year warranty.

In-Shot Burners:

Advanced burner design, quiet operation. NOx models can be converted to LP gas. High altitude kits available.

Integrated DSI Control:

Direct spark ignition control and remote sensor delivers smooth, proven ignition sequence. Timed blower control and diagnostics are also features of integrated control.

Gas Controls:

Honeywell gas valve and burner orifices are factory standard for natural gas. Field convertible to LP gas with certified conversion kit.

Filter Service Door:

Separate service door provides easy access for filter change.

Pre-Painted 20 Gauge Zinc Coated Steel Cabinet:

Cleaned, rinsed, sealed and dried before the polyurethane primer is applied. The cabinet is handsomely finished with a baked on textured enamel, which allows it to withstand 1000 hours of salt spray tests per ASTM B117-03.

16 Gauge Zinc Coated Unit Base

Two-Inch, Pleated Disposable Air Filters:

Are standard equipment.

Condenser Fan and Motor Shroud Assembly:

Slides out for easy access.

Circuit Breakers/Rotary Disconnect:

Standard on all versions of single (230/208 volt) and three phase (230/208 volt) equipment. Rotary disconnects are standard on all versions of three phase (460 volt) equipment.

Slope Top:

Standard feature for water run-off.

Full Length Mounting Brackets:

Built into cabinet for improved appearance and easy installation.

Top Rain Flashing:

Standard feature on all models.

Ventilation Options:

Several ventilation options are available and can be factory or field installed.



- Complies with efficiency requirements of ANSI/ASHRAE/IESNA 90.1-2019.
- Certified to ANSI/AHRI Standard 390-2021 for SPVU (Single Package Vertical Units).
- Intertek ETL Listed to Standard for Safety Heating and Cooling Equipment ANSI/UL 1995, Fifth Edition/CSA 22.2 No. 236-05, Fourth Edition.
- Intertek ETL Listed to Standard for Gas-Fired Central Furnaces ANSI Z21.47-2021, CSA 2.3-2021 Eighth Edition
- Commercial Product - Not intended for Residential application.



Specifications

MODELS	WG3S2-A	WG3S2-B	WG3S2-C	WG4S2-A	WG4S2-B	WG4S2-C	WG5S2-A	WG5S2-B	WG5S2-C
Electrical Rating – 60 Hz	230/208 - 1	230/208 - 3	460 - 3	230/208 - 1	230/208 - 3	460 - 3	230/208 - 1	230/208 - 3	460 - 3
Operating Voltage Range	197-253	187-253	414-506	197-253	187-253	414-506	197-253	187-253	414-506
Minimum Circuit Ampacity	27	23	12	36	27	14	45	31	15
*Field Wire Size/	8	10	14	8	10	12	8	8	12
Ground Wire Size	10	10	14	10	10	12	10	10	12
** Delay Fuse - Max.	40	30	15	45	40	20	60	45	20
Compressor									
Voltage	230/208	230/208	460	230/208	230/208	460	230/208	230/208	460
Rated Load Amps	11.6 / 12.9	8.8 / 9.9	6.7	15.0 / 17.8	10.4 / 11.8	5.4	20.9 / 23.0	12.8 / 14.1	6.2
Branch Circuit									
Selection Current	15.3	11.7	5.8	21.2	14.1	6.5	27.2	16.5	7.2
Lock Rotor Amps	83	73	38	104	83.1	41	152.9	110	52
Compressor Type	Scroll	Scroll	Scroll	Scroll	Scroll	Scroll	Scroll	Scroll	Scroll
Fan Motor & Condenser									
Fan Motor--HP--RPM-SPD	1/3-850-2	1/3-850-2	1/3-850-1	1/3-850-2	1/3-850-2	1/3-850-1	1/3-850-2	1/3-850-2	1/3-850-1
Fan Motor--Amps	2.5	2.5	1.3	2.5	2.5	1.3	2.5	2.5	1.3
Fan--DIA/CFM	24" - 2700	24" - 2700	24" - 2700	24" - 2700	24" - 2700	24" - 2700	24" - 2700	24" - 2700	24" - 2700
Blower Motor & Evap.									
Blower Motor--HP--RPM-SPD	1/2 Variable	1/2 Variable	1/2 Variable	3/4 Variable	3/4 Variable	3/4 Variable	3/4 Variable	3/4 Variable	3/4 Variable
Blower Motor--Amps	3.6	3.6	3.6	4.7	4.7	4.7	6.0	6.0	6.0
CFM Cooling - 1st Stage	800	800	800	1100	1100	1100	1300	1300	1300
CFM Cooling - 2nd Stage	1100	1100	1100	1500	1500	1500	1700	1700	1700
Filter Size	20 x 30 x 2	20 x 30 x 2	20 x 30 x 2	20 x 30 x 2	20 x 30 x 2	20 x 30 x 2	20 x 30 x 2	20 x 30 x 2	20 x 30 x 2
Charge (R-410A)	156	156	156	240	240	240	246	246	246
Shipping Weight --LBS.	585	585	630	685	685	730	710	710	755

* Based on 75°C copper wire. All wiring must conform to the National Electrical Code and all local codes.

** Maximum time delay fuse or HACR type circuit breaker.

① Add 45 lbs. for factory installed WGSCRVMP-5 Commercial Room Ventilator or WGSJIFM-5 Economizer, and 90 lbs. for WGSERV-5 Energy Recovery Ventilator.

Cooling System Capacity, Efficiency & Airflow Ratings

Models	WG3S2	WG4S2	WG5S2
Cooling Capacity BTUH, 2nd Stage Operation ①	35,000	46,500	56,500
EER 2nd Stage Operation ①	11.3	11.7	11.2
Rated CFM, Wet Coil	1100	1400	1600
Cooling Capacity BTUH, 1st Stage Operation	24,000	33,600	41,500
EER 1st Stage Part Load Operation (80/67-80)	14.5	15.0	14.0
Rated CFM, Wet Coil	800	1100	1300
IPLV (Certified to ARI Standard 390-2003)	13.8	15.1	14.0

Heating System Capacity, Efficiency and Airflow Ratings

Factory Standard Heating Capacity Options & Performance — See Note ① Below

Model Heating Input Code	A	B	C
Input BTUH	45,000	68,000	90,000
Output BTUH (Heating Capacity) ②	37,000	56,000	74,000
Thermal Efficiency (T.E.) ②	82.0	82.0	82.0
Temperature Rise Range (F)	25 - 55	30 - 60	40 - 70
Constant Heating CFM/Constant Rise (F)	960/30	1100/45	1365/45

① Any input can be selected for each model.

② Heating ratings certified in accordance with ANSI Z21.47-2006.

Indoor Blower Performance ①

MODEL	Rated ESP	Max ESP	② Continuous CFM	③ Rated 1st Stage Cooling CFM	④ Rated 2nd Stage Cooling CFM	Heating CFM ⑤⑥			
						50,000 BTU Input	75,000 BTU Input	100,000 BTU Input	125,000 BTU Input
WG3S2	0.15	0.50	800	800	1100	960	1100	1365	1440
WG4S2	0.20	0.50	825	1100	1400	960	1100	1365	1440
WG5S2	0.20	0.50	850	1300	1600	960	1100	1365	1440

① Motor will deliver consistent CFM through voltage supply range with no deterioration (197-253V for 230/208V models, 414-506V for 460V models).

② Continuous CFM is the total air being circulated during continuous (manual) fan mode.

③ Will occur automatically with a call for "Y1" signal from thermostat.

④ Will occur automatically with a call for "Y2" signal from thermostat.

⑤ Will occur automatically with a call for "W" signal from thermostat.

⑥ Constant CFM of Variable Speed Motor should maintain mid-rise temperature differential through range of allowable static.

Ventilation System Packages

Bard Wall-Mounts are designed to provide optional ventilation packages to meet all of your ventilation and indoor air quality requirements. All ventilation packages can be built-in at the factory, or field-installed at a later date.

BLANK OFF PLATE - WGSBOP

A blank off plate is installed on the inside of the service door. It covers the air inlet openings which restricts any outside air from entering the unit. The blank off plate should be utilized in applications where outside air is not required to be mixed with the conditioned air.

STANDARD



COMMERCIAL ROOM VENTILATOR

COMMERCIAL ROOM VENTILATOR - WGSCRVP-5

The built-in commercial room ventilator is internally mounted behind the service door and allows outside ventilation air, up to 50% of the total airflow rating of the unit, to be introduced through the air inlet openings. It includes a built-in exhaust air damper with integral bug screen. Automatic control is integrated to maintain desired ventilation air at the various supply airflows while on Stage 1, Stage 2 or ventilation modes of operation.

OPTIONAL

The commercial room ventilator (CRV) is a simple and innovative approach to improving the indoor air quality by providing fresh air intake and exhaust capability through the CRV. The damper can be easily adjusted to control the amount of fresh air supplied into the building. The CRV can be controlled by indoor blower operation or field controlled based on room occupancy. The CRV is power open - spring return on power loss. Complies with ANSI/ASHRAE Standard 62.1 "Ventilation for Acceptable Indoor Air Quality".

CO₂ Sensor Ready:

- WGSCRVP-5 is designed for CO₂ based on ventilation control by simply wiring in a field installed CO₂ sensor if desired.



ECONOMIZER

ECONOMIZER - WGSJIFM-5

The built-in economizer system is internally mounted behind the service door and allows outdoor air to be introduced through the air inlet openings. The amount of outdoor air varies in response to the system controls and settings defined by the end user. It includes a built-in exhaust air damper. The economizer is designed to provide "free cooling" when outside air conditions are cool and dry enough to satisfy cooling requirements without running the compressor. This in turn provides lower operating costs, while extending the life of the compressor.

OPTIONAL

Standard Features:

- One Piece Construction - Easy to install with no mechanical linkage adjustment required.
- Exhaust Air Damper - Built in with positive closed position. Provides exhaust air capability to prevent pressurization of tight buildings.
- Actuator Motor - 24 volt, power open, spring return with built in torque limiting switch.
- Proportioning Type Control - for maximum "free cooling" economy and comfort.
- Moisture Eliminator & Prefilter - permanent, washable aluminum construction.
- Enthalpy Control - adjustable to monitor outdoor temperature and humidity.
- Honeywell JADE™ electronic economizer module with precision settings and diagnostics.
- Mixed Air Sensor - to monitor outside and return air to automatically modulate damper position.



ENERGY RECOVERY VENTILATOR

WALL-MOUNT ENERGY RECOVERY VENTILATOR - WGSERV-5

The wall-mount energy recovery ventilator (WGSERV-5) is a highly innovative approach to address indoor air quality ventilation requirements as established by ANSI/ASHRAE Standard 62.1. The WGSERV-5 allows up to 450 CFM (depending upon speed setting) of fresh air and exhaust through the unit while maintaining superior indoor comfort and humidity levels. In most cases this can be accomplished without increasing equipment sizing or operating costs. Heat transfer efficiency is up to 74% during summer and 80% during winter conditions.

OPTIONAL

The WGSERV-5 consists of a unique "rotary energy recovery cassette" that provides effective sensible and latent heat transfer capabilities during summer and winter conditions. Various control schemes are addressed including limiting ventilation during building occupancy only.

The WGSERV-5 is designed to be internally mounted behind the service door in the WGS Gas/Electric units. It can be built-in at the factory or field installed as an option. WGSERV-5 can be independently adjusted for intake and exhaust rates.

NOTE: See Page 4 for WGSCRVP Performance Data & Page 5 & 6 for WGSERV Performance Data

WGSJFM-5 Economizer and WGSCRVMP-5 Commercial Ventilator Airflow

WG3S Ventilation Airflow

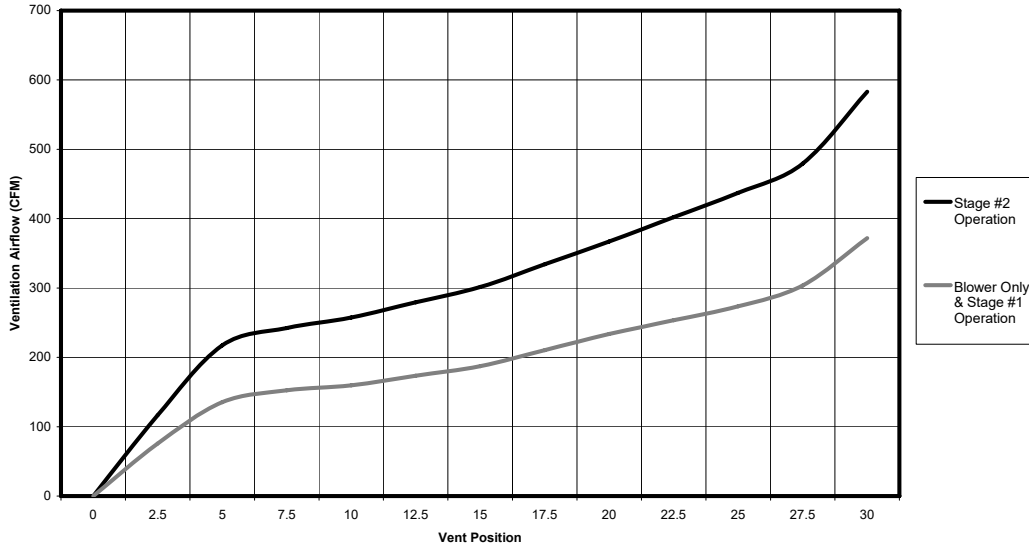

WG4S Ventilation Airflow

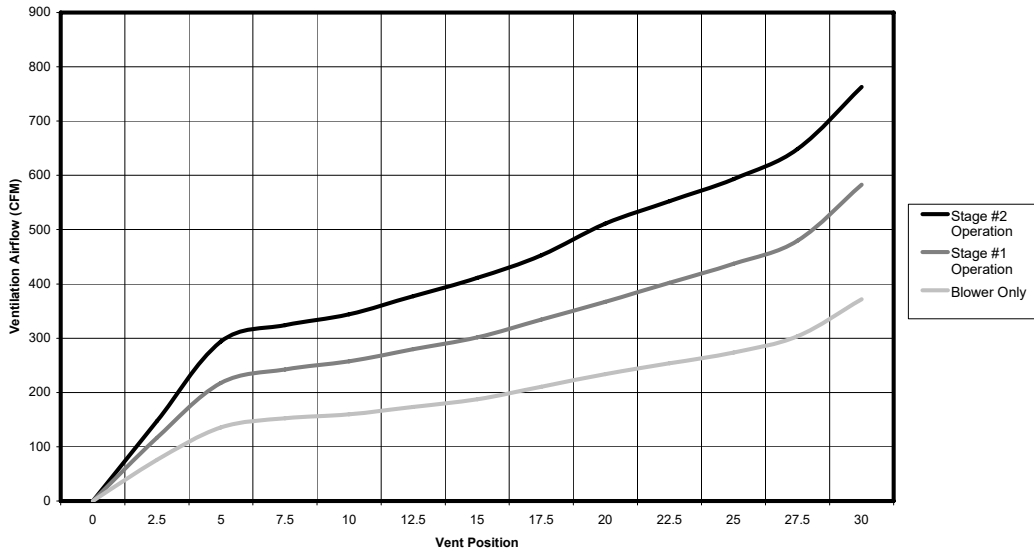

WG5S Ventilation Airflow

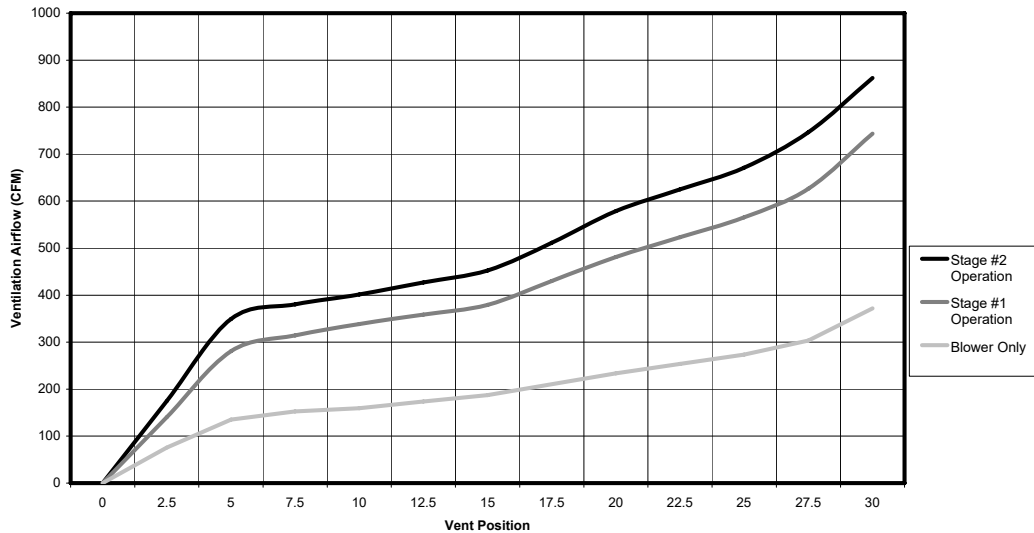

Energy Recovery Ventilator Performance Data — WGSERV-A5 (230V) & WGSERV-C5 (460V)

APPLICATION DATA — WGSERV-A5A, -C5A SUMMER COOLING PERFORMANCE (INDOOR DESIGN CONDITIONS 75°DB/62°WB)

Ambient O.D.	VENTILATION RATE -- 450CFM High Speed (Black) 60% EFFICIENCY							VENTILATION RATE -- 370 CFM Medium Speed (Blue) 62% EFFICIENCY						VENTILATION RATE -- 280 CFM Low Speed (Red) 64% EFFICIENCY					
	DB/ WB	F	VLT	VLS	VLL	HRT	HRS	HRL	VLT	VLS	VLL	HRT	HRS	HRL	VLT	VLS	VLL	HRT	HRS
105	75	21465	14580	6884	12879	8748	4131	17649	11988	5661	10942	7433	3510	13356	9072	4284	8548	5806	2742
	70	14580	14580	0	8748	8748	0	11988	11988	0	7433	7433	0	9072	9072	0	5806	5806	0
	65	14580	14580	0	8748	8748	0	11988	11988	0	7433	7433	0	9072	9072	0	5806	5806	0
100	80	31500	12150	19440	18900	7290	11610	25900	9990	15910	16058	6194	9864	19600	7560	12040	12544	4838	7706
	75	21465	12150	9314	12879	7290	5589	17649	9990	7659	10942	6194	4749	13356	7560	5796	8548	4838	3709
	70	12352	12150	202	7411	7290	121	10156	9990	166	6297	6194	103	7686	7560	126	4919	4838	80
	65	12150	12150	0	7290	7290	0	9990	9990	0	6194	6194	0	7560	7560	0	4838	4838	0
	60	12150	12150	0	7290	7290	0	9990	9990	0	6194	6194	0	7560	7560	0	4838	4838	0
95	80	31590	9720	21870	18954	5832	13122	25974	7992	17982	16104	4955	11149	19656	6048	13608	12580	3871	8709
	75	21465	9720	11744	12879	5832	7047	17649	7992	9657	10942	4955	5987	13356	6048	7308	8548	3871	4677
	70	12352	9720	2632	7411	5832	1579	10156	7992	2164	6297	4955	1342	7686	6048	1638	4919	3871	1048
	65	9720	9720	0	5832	5832	0	7992	7992	0	4955	4955	0	6048	6048	0	3871	3871	0
	60	9720	9720	0	5832	5832	0	7992	7992	0	4955	4955	0	6048	6048	0	3871	3871	0
90	80	31590	7290	24300	18954	4374	14580	25974	5994	19980	16104	3716	12388	19656	4536	15120	12580	2903	9677
	75	21465	7290	14175	12879	4374	8505	17649	5994	11655	10942	3716	7226	13356	4536	8820	8548	2903	5645
	70	12352	7290	5062	7411	4374	3037	10156	5994	4162	6297	3716	2580	7686	4536	3150	4919	2903	2016
	65	7290	7290	0	4374	4374	0	5994	5994	0	3716	3716	0	4536	4536	0	2903	2903	0
	60	7290	7290	0	4374	4374	0	5994	5994	0	3716	3716	0	4536	4536	0	2903	2903	0
85	80	31590	4860	26730	18954	2916	16038	25974	3996	21978	16104	2478	13626	19656	3024	16632	12580	1935	10644
	75	21465	4860	16605	12879	2916	9963	17649	3996	13653	10942	2478	8465	13356	3024	10332	8548	1935	6612
	70	12352	4860	7492	7411	2916	4495	10156	3996	6160	6297	2478	3819	7686	3024	4662	4919	1935	2983
	65	4860	4860	0	2916	2916	0	3996	3996	0	2478	2478	0	3024	3024	0	1935	1935	0
	60	4860	4860	0	2916	2916	0	3996	3996	0	2478	2478	0	3024	3024	0	1935	1935	0
80	75	21465	2430	19035	12879	1458	11421	17649	1998	15651	10942	1239	9704	13356	1512	11844	8548	968	7580
	70	12352	2430	9922	7411	1458	5953	10156	1998	8158	6297	1239	5058	7686	1512	6174	4919	968	3951
	65	4252	2430	1822	2551	1458	1093	3496	1998	1498	2168	1239	929	2646	1512	1134	1693	968	726
	60	2430	2430	0	1458	1458	0	1998	1998	0	1239	1239	0	1512	1512	0	968	968	0
75	70	12352	0	12352	7411	0	7411	10156	0	10156	6297	0	6297	7686	0	7686	4919	0	4919
	65	4252	0	4252	2551	0	2551	3496	0	3496	2168	0	2168	2646	0	2646	1693	0	1693
	60	0	0	0	0	0	0	0	0	0	0	0	0	0	0	0	0	0	0

WGSERV-A5A, -C5A WINTER HEATING PERFORMANCE (INDOOR DESIGN CONDITIONS 70°F DB)

LEGEND:

- VLT** = Ventilation Load - Total
- VLS** = Ventilation Load - Sensible
- VLL** = Ventilation Load - Latent
- HRT** = Heat Recovery - Total
- HRS** = Heat Recovery - Sensible
- HRL** = Heat Recovery - Latent
- WVL** = Winter Ventilation Load
- WHR** = Winter Heat Recovery

Ambient O.D.	VENTILATION RATE						
	450 CFM 77% EFFICIENCY		370 CFM 78% EFFICIENCY		280 CFM 79% EFFICIENCY		
	DB/°F	WVL	WHR	WVL	WHR	WVL	WHR
65	2430	1870	2000	1560	1510	1190	
60	4860	3740	4000	3120	3020	2390	
55	7290	5610	5990	4680	4540	3580	
50	9720	7480	8000	6230	6050	4780	
45	12150	9360	9990	7790	7560	5970	
40	14580	11230	11990	9350	9070	7170	
35	17010	19100	13990	10910	10580	8360	
30	19440	14970	15980	12470	12100	9560	
25	21870	16840	17980	14030	13610	10750	
20	24300	18710	19980	15580	15120	11950	
15	26730	20580	21980	17140	16630	13140	

NOTE: Sensible performance only is shown for winter application.

WGS Sound Data

WG3S2	Vent	1st Stage	2nd Stage
Front	33.5	41.8	42.9
45° Right	31.1	38.8	39.1
45° Left	30.8	38.0	39.3

WG4S2	Vent	1st Stage	2nd Stage
Front	34.9	41.8	44.2
45° Right	32.5	38.4	41.4
45° Left	32.3	38.5	40.7

WG5S2	Vent	1st Stage	2nd Stage
Front	35.0	44.5	44.8
45° Right	33.2	41.4	42.6
45° Left	33.0	41.3	42.3

NOTE: All measurements recorded five feet from the unit and five feet from the floor.

Important Information Concerning Altitude Impact on Heating Input Ratings

Heating input, and thus heating output, decreases with altitude. No orifice change is required up to 6,000 feet elevation and derate occurs naturally due to altitude impact. **Natural gas models may require orifice change based on BTU content of gas. See Natural Gas Orifice and Altitude Tables on next page for details.** For Propane Gas see the Propane Gas Conversion Table below.

Above 6,000 feet elevation orifice changes are required, and capacity reductions are a function of altitude impact and orifice change. Pressure switch change is required above 6,000 feet elevation. For Natural Gas see the Orifice and Altitude Tables on next page. For Propane Gas see the Propane Gas Conversion Table below.

NATURAL GAS DERATE CAPACITIES											
WG Rated Input	Sea Level	1000	2000	3000	4000	5000	6000	7000	8000	9000	10,000
45,000	45,000	43,560	42,120	40,680	39,600	38,880	37,980	37,440	36,720	36,270	35,640
68,000	67,500	65,340	63,180	61,020	59,400	58,320	56,970	56,160	55,080	54,405	53,460
90,000	90,000	87,120	84,240	81,360	79,200	77,760	75,960	74,880	73,440	72,540	71,280

PROPANE (LP) DERATE CAPACITIES											
WG Rated Input	Sea Level	1000	2000	3000	4000	5000	6000	7000	8000	9000	10,000
45,000	45,000	44,280	43,920	43,560	42,840	42,480	41,760	40,680	39,600	38,160	36,360
68,000	68,000	66,420	65,880	65,340	64,260	63,720	62,640	61,020	59,400	57,240	54,540
90,000	90,000	88,560	87,840	87,120	85,680	84,960	83,520	81,360	79,200	76,320	72,720

Gas Pressure Inches W.C.

Minimum permissible gas supply pressure for purpose of input adjustment:	Natural 4.5	LP 11.0
Maximum permissible gas supply pressure for purpose of input adjustment:	Natural 11.0	LP 13.0
Manifold Pressure:	Natural 3.5	LP 10.0

Propane Gas Conversion Kits -- Fits All WG-Series Models

PROPANE (LP) GAS -- Use Gas Conversion Kits As Indicated					
MODELS	Propane Gas Conversion Kit		Use WGCK-1	Use WGCK-2	
WG3S	Factory Standard Input	Gas Heat Value BTU/Cu. Ft.	Up to 6000 Feet	6001 to 8000 Feet Requires Pressure Switch Change and Orifice as Shown	8001 to 10,000 Feet Requires Pressure Switch Change and Orifice as Shown
WG4S			Install Orifice		
WG5S	22,500 - 22,650 BTU Per Burner	2500	1.45	1.45	1.40
		Pressure Switch	Standard (.55)	Pressure Switch (.42) Included in Conversion Kit	

All orifice sizes shown are millimeters (mm).

Natural Gas Orifice and Altitude Tables

Factory Standard Input	Gas Heat* Value BTU/Cu. Ft.	Up to 6000 Feet No Changes Except For BTU Content	6001 to 8000 Feet Requires Pressure Switch Change and Orifice Change Based on BTU Content	8001 to 10,000 Feet Requires Pressure Switch Change and Orifice Change Based on BTU Content
22,500 BTU Per Burner	700-749	2.75	2.70	2.60
	750-799	2.70	2.60	2.50
	800-849	2.60	2.50	
	850-899	2.50	2.45	2.40
	900-949	2.40	2.35	[2.30]
	950-999	2.35	[2.30]	2.25
	1000-1049**	[2.30]	2.25	2.20
	1050-1100	2.25	2.25	2.20
	Pressure Switch	Standard (.55)	Order 8620-189 High Altitude Pressure Switch Kit (.42)	
[2.30] is the standard factory installed orifice size				

* At standard conditions: 30.00 Inches Mercury, 60F, Saturated, .60 Specific Gravity

** All Natural Gas factory orifice sizing and standard input ratings based on nominal 1025 BTU per cubic foot gas and sea level conditions.

All other orifice sizes shown are available as individual items. See Orifice charts below for part numbers and number required.

Bard Part No.	Orifice Size (mm)	Orifice Diameter
9010-092	2.10	0.0826
9010-088	2.15	0.0846
9010-087	2.20	0.0866
9010-086	2.25	0.0885
9010-082	2.30	0.0905
9010-085	2.35	0.0925
9010-079	2.40	0.0945
9010-084	2.45	0.0964
9010-093	2.50	0.0984
9010-094	2.60	0.1024
9010-095	2.70	0.1063
9010-096	2.75	0.1082
9010-097	2.80	0.1102
9010-098	2.90	0.1142

No. of Orifices Required Based on Unit Input Rating
45,000 (2)
68,000 (3)
90,000 (4)

2nd Stage Cooling Application Data - Outdoor Temperature ^①

Model	DB/WB ^②	Cooling Capacity	50°F	55°F	60°F	65°F	70°F	75°F	80°F	85°F	90°F	95°F	100°F	105°F	110°F	115°F	
WG3S2	75/62	Total Cooling	44,750	43,350	41,975	40,575	39,200	37,800	36,350	34,875	33,425	31,975	30,850	29,725	28,625	27,500	
		Sensible Cooling	32,900	32,275	31,625	30,975	30,330	29,700	29,025	28,350	27,650	26,975	26,475	26,000	25,500	25,000	
	80/67	Total Cooling	49,775	48,150	46,550	44,925	43,325	41,700	39,925	38,150	36,375	34,600	34,600	33,625	32,675	31,725	30,750
		Sensible Cooling	32,825	32,150	31,500	30,825	30,175	29,500	28,750	28,000	27,225	26,475	26,475	26,175	25,900	25,600	25,300
WG4S2	75/62	Total Cooling	52,025	50,800	49,575	48,350	47,125	45,900	44,850	43,800	42,750	41,725	39,775	37,775	37,850	35,925	34,000
		Sensible Cooling	32,600	32,000	31,350	30,750	30,125	29,500	28,825	28,150	27,475	26,775	26,775	26,400	26,000	25,600	25,200
	80/67	Total Cooling	56,025	54,500	52,975	51,450	49,925	48,400	46,950	45,500	44,050	42,600	42,600	40,775	38,950	37,125	35,300
		Sensible Cooling	40,400	39,775	39,150	38,525	37,925	37,300	36,800	36,300	35,775	35,275	35,275	34,200	33,150	32,075	31,000
WG5S2	80/67	Total Cooling	62,350	60,600	58,850	57,100	55,350	53,600	51,825	50,050	48,275	46,500	46,500	44,850	43,200	41,550	39,900
		Sensible Cooling	41,475	40,700	39,925	39,150	38,375	37,600	36,800	36,000	35,175	34,375	34,375	33,725	33,100	32,450	31,800
	85/72	Total Cooling	69,425	67,525	65,625	63,725	61,825	59,900	57,975	56,050	54,125	52,200	52,200	50,375	48,550	46,725	44,900
		Sensible Cooling	41,625	40,875	40,130	39,375	38,625	37,900	37,175	36,450	35,725	34,975	34,975	34,175	33,375	32,575	31,800
WG6S2	75/62	Total Cooling	69,700	67,800	65,900	64,000	62,100	60,250	58,325	56,400	54,475	52,525	52,525	50,800	49,075	47,350	45,600
		Sensible Cooling	49,875	49,050	48,225	47,400	46,575	45,800	44,975	44,150	43,325	42,525	42,525	41,725	40,925	40,125	39,300
	80/67	Total Cooling	74,750	72,775	70,800	68,825	66,850	64,850	62,775	60,675	58,600	56,500	56,500	54,950	53,400	51,850	50,300
		Sensible Cooling	48,325	47,550	46,775	46,000	45,225	44,400	43,500	42,600	41,700	40,800	40,800	40,475	40,150	39,825	39,500
85/72	Total Cooling	79,800	78,000	76,200	74,400	72,600	70,800	69,125	67,450	65,725	64,125	64,125	61,800	59,475	57,150	54,850	
	Sensible Cooling	46,650	46,075	45,500	44,925	44,350	43,750	43,200	42,650	42,100	41,550	41,550	40,875	40,200	39,525	38,800	

1st Stage Cooling Application Data - Outdoor Temperature ^①

Model	DB/WB ^②	Cooling Capacity	50°F	55°F	60°F	65°F	70°F	75°F	80°F	85°F	90°F	95°F	100°F	105°F	110°F	115°F
WG3S2	75/62	Total Cooling	30,925	29,825	28,725	27,625	26,525	25,400	24,225	23,050	21,875	20,700	19,875	19,050	18,225	17,400
		Sensible Cooling	23,350	22,750	22,150	21,550	20,950	20,400	19,750	19,100	18,450	17,825	17,825	17,450	17,075	16,700
	80/67	Total Cooling	35,050	33,750	32,450	31,150	29,850	28,600	27,200	25,800	24,400	23,000	22,150	21,300	20,450	19,600
		Sensible Cooling	23,675	23,050	22,425	21,800	21,175	20,500	19,775	19,050	18,325	17,575	17,325	17,075	16,825	16,600
WG4S2	85/72	Total Cooling	38,750	37,400	36,050	34,700	33,350	32,000	30,550	29,100	27,650	26,150	25,250	24,350	23,450	22,550
		Sensible Cooling	22,975	22,450	21,925	21,400	20,875	20,400	19,825	19,250	18,675	18,125	17,825	17,825	17,525	17,225
	75/62	Total Cooling	41,275	40,075	38,875	37,675	36,475	35,300	34,100	32,900	31,700	30,525	29,325	28,125	26,925	25,700
		Sensible Cooling	29,650	29,125	28,600	28,075	27,550	27,000	26,475	25,950	25,425	24,925	24,925	24,350	23,775	23,200
WG5S2	80/67	Total Cooling	45,675	44,350	43,025	41,700	40,350	39,000	37,650	36,300	34,950	33,600	32,325	31,050	29,775	28,500
		Sensible Cooling	30,075	29,475	28,875	28,275	27,675	27,100	26,475	25,850	25,225	24,600	24,125	23,650	23,175	22,650
	85/72	Total Cooling	51,525	50,000	48,475	46,950	45,425	43,900	42,300	40,700	39,100	37,450	36,250	35,050	33,875	32,700
		Sensible Cooling	30,850	30,150	29,450	28,750	28,050	27,400	26,650	25,900	25,150	24,350	23,950	23,550	23,150	22,750
WG6S2	75/62	Total Cooling	50,000	48,750	47,500	46,250	45,000	43,750	42,675	41,600	40,525	39,425	37,500	35,575	33,650	31,700
		Sensible Cooling	36,800	36,325	35,850	35,375	34,900	34,450	34,075	33,700	33,325	32,950	32,100	31,225	30,350	29,500
	80/67	Total Cooling	58,550	56,600	54,650	52,700	50,750	48,850	46,775	44,700	42,600	40,500	39,150	37,800	36,450	35,100
		Sensible Cooling	37,850	37,150	36,450	35,750	35,050	34,350	33,525	32,700	31,875	31,075	30,850	30,625	30,400	30,200
85/72	Total Cooling	62,125	60,450	58,775	57,100	55,425	53,800	52,175	50,550	48,925	47,325	45,475	43,625	41,775	39,950	
	Sensible Cooling	35,950	35,550	35,150	34,750	34,350	33,900	33,550	33,200	32,850	32,550	31,850	31,175	30,500	29,800	

① Below 50°F requires a factory of field installed low ambient control.

② Return air temperature °F

SHIPPING CRATES

<i>UNIT</i>	<i>CRATE</i>
W3GS	8620-355
W4GS, W5GS	8620-356

DIMENSIONS OF BASIC UNIT

UNIT	A	B	C	D	E	F	G	H	I	J	K	L	M	N	O	P	Q	R
WG3S2	9.88	29.88	15.88	27.25	43.81	14.88	31.63	87.5	30	33.38	28.75	14.12	15.44	15.31	42.88	4.5	2.5	3.75
WG4S2/WG5S2							41.63	97.5		43.38	38.75							

UNIT	S	T	U	V	W	X	Y	Z	AA	BB	CC	DD	EE	FF	GG	HH	II
WG3S2	16	3.75	3.88	24.9	42	17.34	8.44	2.25	12.19	3.25	10	7.25	40.25	1.13	1.25	2.75	0.44
WG4S2/WG5S2		13.75		34.9													

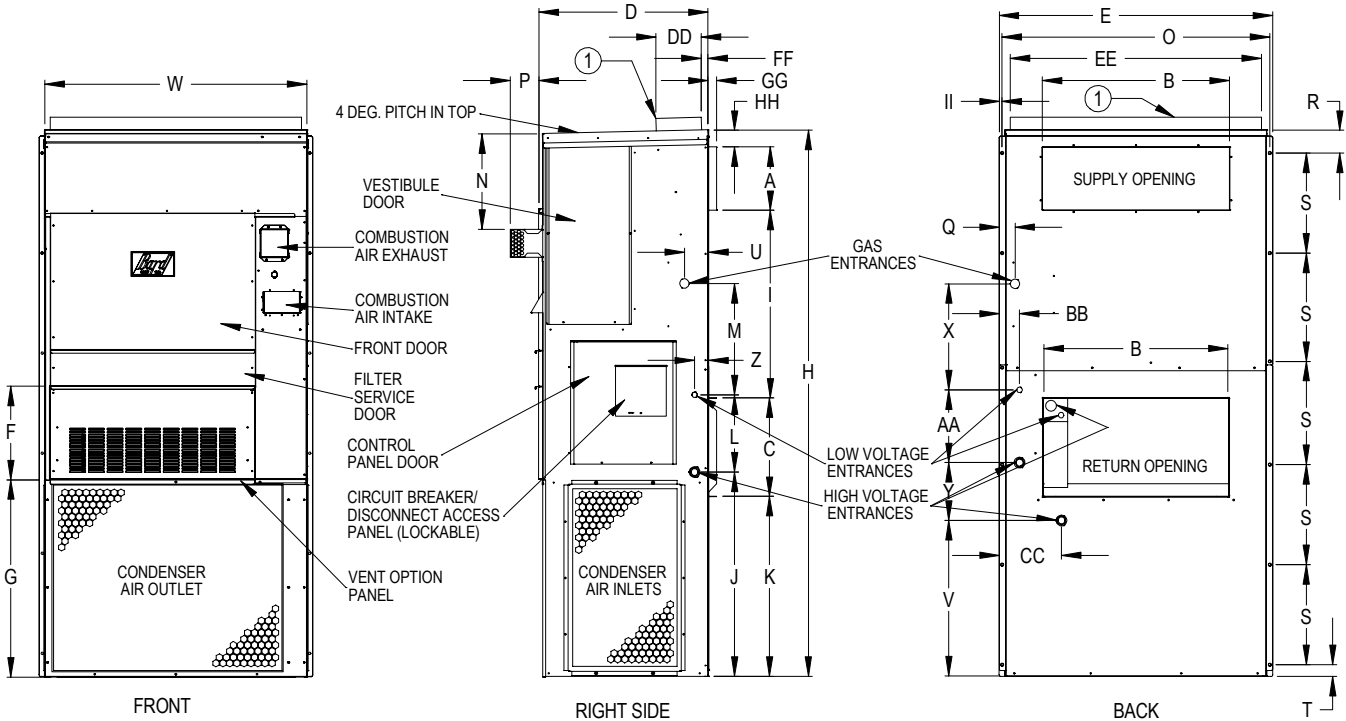

① Optional top outlet in place of standard front supply opening, see Nomenclature outlet options (next page). Standard unit can also be field converted to this configuration using approved top supply outlet conversion kit shown on next page.

**FIGURE 1
COMBUSTIBLE CLEARANCE**

MIS-3240 B

Minimum Clearances	
Outlet Duct (from combustible materials)	1" first 3'
Vent Terminal (from combustible materials)	17"
Condenser Outlet	20"
Top	See Figure 1
Burner Service	20"
Combustible Base (Wood or Class A, B or C roof covering material)	0"

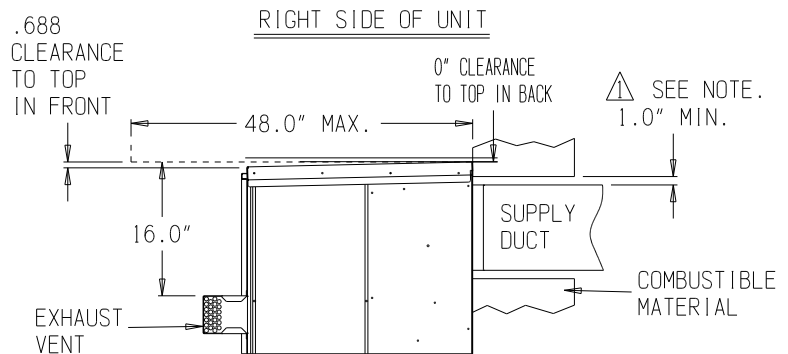

⚠ SIDE SECTION VIEW OF SUPPLY AIR DUCT FOR WALL MOUNTED UNIT SHOWING 1.0" CLEARANCE TO ALL COMBUSTIBLE SURFACES.

MIS-1714

WARNING

A **minimum** of one (1) inch clearance must be maintained between the supply air duct and combustible materials. This is required for the first three (3) feet of ducting.

It is important to insure that the one (1) inch minimum spacing is maintained at all points.

Failure to do this could result in overheating the combustible material and may result in a fire causing damage, injury or death.

Air Conditioning Wall-Mount Model Nomenclature

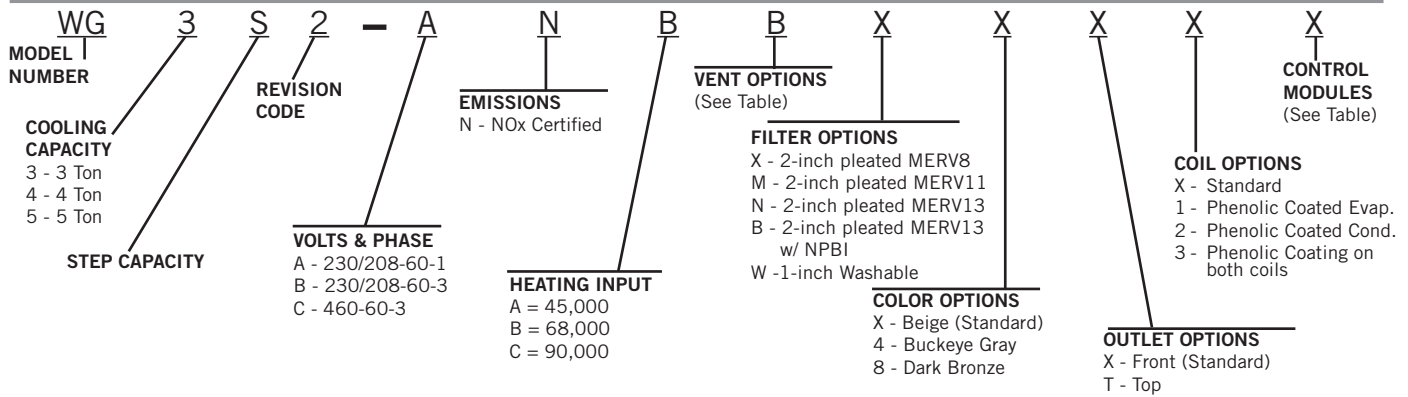

Ventilation Options

Models	WG3S, WG4S, WG5S	
Description	Factory Installed Code No.	Field Installed Part No.
Blank-Off Plate (Standard)	B	WGBOP-5
Commercial Ventilator - Spring Return w/Exhaust	V	WGSCRVMP-5
Economizer (Internal) Fully Modulating w/Exhaust ①	E	WGSJIFM-5
Energy Recovery Ventilator - 230 Volt w/Exhaust ②	R	WGSERV-A5A-*
Energy Recovery Ventilator - 460 Volt w/Exhaust ②	R	WGSERV-C5A-*

① Low ambient control is required with economizer for low temperature compressor operation.

② Independent selection of intake and exhaust speeds (rate) with terminal block selection.

* Color option must be specified to match unit ("X" = Beige; "4" = Buckeye Gray; "8" = Dark Bronze)

Top Supply Outlet Conversion Kits-Field Installed (Convert Standard Front Outlet to Top Outlet)

USED WITH MODELS	UNIT COLOR X - BEIGE	UNIT COLOR 4 - BUCKEYE GRAY	UNIT COLOR 8 - DARK BRONZE
WG3S, WG4S, WG5S	TSO-WG5-X	TSO-WG5-4	TSO-WG5-8

Air Conditioning Control Modules (All Modules Except as Noted)

HPC ①	LPC ②	CCM ③	LAC ④	SK ⑤	Factory Installed Code	Field Installed Code
STD	STD	STD			X	N/A
STD	STD	STD	●		H	CMA-28
STD	STD	STD		●	Field Installed Only	SK114 for WG3S2-A
STD	STD	STD		●	Field Installed Only	SK111 for WG4S2-A
STD	STD	STD		●	Field Installed Only	SK115 for WG5S2-A

STD = Standard equipment for these specified models.

① HPC. High pressure control is auto reset. Always used with compressor control module (CCM) which is included. See note ③.

② LPC. Low pressure control is auto reset. Always used with compressor control module (CCM) which is included. See note ③.

③ CCM. Compressor control module has adjustable 30-second to 5-minute delay-on-break timer. On initial power-up, or any time the power is interrupted, the delay-on-make will be 2-minutes plus 10% of the delay-on-break setting. There is no delay-on-make during routine operation of the unit. The module also provides the lockout feature (with 1 retry) for high and/or low-pressure controls, and a 2-minute timed bypass for low-pressure control.

④ LAC. Low ambient control permits cooling operation down to 0°F.

⑤ SK. Start capacitor and potential relay start kit can be used with all -A single phase models. Increases starting torque 9x. Not used for -B or -C three phase models.

Optional Field Installed Accessories

DESCRIPTION	PART NUMBER
Natural Gas High Altitude Pressure Switch Kit (6000 - 10,000 Feet)	8620-189
<i>Note: Natural Gas Orifice Change May Be Required Depending Upon Altitude and Gas BTU content. See Orifice and Altitude Tables.</i>	
Propane Gas Conversion Kit (0 - 6000 Feet Altitude)	WGCK-1
Propane Gas Conversion Kit (6000 - 10,000 Feet Altitude)	WGCK-2
Vertical Vent Kit (Includes all parts for 5 foot vertical vent)	VVK-5A
Additional 1 foot vertical vent pipe section for VVK-5A	8620-201
Additional 2 foot vertical vent pipe section for VVK-5A	8620-170
Additional 3 foot vertical vent pipe section for VVK-5A	8620-200
Additional 5 foot vertical vent pipe section for VVK-5A	8620-171



Bard Manufacturing Company, Inc.
Bryan, Ohio 43506
www.bardhvac.com

Due to our continuous product improvement policy, all specifications subject to change without notice.

Before purchasing this appliance, read important energy cost and efficiency information available from your retailer.

Form No.
S3489
November 2023

Supersedes: S3489-522