



DUAL-TEC™ WALL-MOUNT™ Air Conditioners with -48VDC Blower Motor DC Voltage 100% Free Cooling Unit

**D36A/L 1-Stage
Right & Left-Hand Control Panel**

**GREEN REFRIGERANT
R-410A**

The Bard DUAL-TEC™ Wall Mount™ Air Conditioners with -48VDC Blower Motor and DC Voltage Free Cooling Economizer are designed for maximum indoor cooling at the most efficient operating cost for year-round operation in the demanding equipment shelter environment.

The DUAL-TEC™ units operate on both AC and -48VDC positive ground power under normal power supply conditions. If there is loss of AC power supply (shore &/or back-up generator) the DUAL-TEC™ will continue to operate as free-cooling or ventilation system using the shelter's DC power. The DUAL-TEC™ indoor blower and economizer operate from -48VDC and no inverter is required.

The DUAL-TEC™ units will supply up to 100% of rated cooling airflow in free cooling mode with the ability to exhaust the same amount through the unit itself without any additional relief openings in the shelter.

DUAL-TEC™ Special Features

Brushless -48VDC Indoor Blower Motor:

Features low sound levels and soft-start capabilities. Soft start function helps to ensure DC power levels will not decrease on start up, and brushless design ensures low DC power noise. The motor is self-adjusting to provide the proper airflow rate without user adjustment or wiring changes.

DC Polarity Monitor:

Includes diagnostics and protects critical DC components against reverse polarity and out-of-range DC power. Range is 40-60 VDC.

Remote Monitoring:

Bard-Link™ web interface with use of LC Controller.

100% Free Cooling Unit Ventilator:

All units are equipped with a full-flow free cooling ventilator. The ventilator uses DC power for operation in conjunction with the -48VDC Indoor Blower during AC power loss. Modulating air intake allows precision temperature control inside the structure while maximizing energy savings.

PLC Logic Board:

All units are equipped with a PLC Logic Board for advanced unit operation and alarm capability. The PLC Logic Board allows for "orphan mode" unit operation if communication with the LC controller is lost.



Bard DUAL-TEC™

Standard Engineered Features — All Models

Copper Tube / Aluminum Fin Coils:

Grooved copper tubing and enhanced aluminum fins provide maximum heat transfer and high energy efficiency. Optional phenolic-coated coils are also available.

Extreme Outdoor Temperature Rating:

D36A/L & D42A/L units are rated up to 131°F outdoor ambient temperature operation.

Air Conditioner Compressor:

Scroll compressors are designed for increased efficiency, quieter operation and improved reliability for longer life.

R-410A Refrigerant:

Designed with R-410A (HFC) non-ozone depleting refrigerant in compliance with the Montreal protocol and 2010 EPA requirements.

PTCR Motor Starting Device:

Standard on 1-phase models, increases compressor motor starting torque 2-3 times. Optional factory or field installed hard start kit available, replaces PTCR device.

Galvanized 20 Gauge Zinc Coated Steel Cabinet:

Cleaned, rinsed, sealed and dried before the polyurethane primer is applied. The cabinet is handsomely finished with a baked on textured enamel, which allows it to withstand 1000 hours of salt spray tests per ASTM B117-03. Condenser section and entire cabinet coatings are also available.

Foil Faced Insulation:

Standard on all units.

Full Length Mounting Brackets:

Built into cabinet for improved appearance and easy installation. **NOTE:** Bottom mounting bracket included to assist in installation.

Liquid Line Filter Drier:

Standard on all units. Protects system against moisture.

24V Transformer:

75VA with circuit breaker.

Electric Heat Strips:

Features an automatic limit and thermal cut-off safety control. Heater packages are factory installed for all 2½ through 5 ton models.

Two-Inch, MERV 8 Air Filters:

Are standard equipment. All models include tight-sealing U-channel filter bracket to minimize air bypass around the filter.

Built-In Circuit Breakers:

HACR-type circuit breakers are standard for AC power supply, and DC rated circuit breaker used for -48VDC power circuit.

High & Low Pressure Switches are Auto-Reset:

Standard on all units. Built-in lock-out circuit resets from the shelter Bard-Link™ Controller. Provides commercial quality protection to the compressor.

Refrigerant Sight Glass:

Standard on all units.

Low Ambient Control:

Modulating LAC standard on all models. Screw-on fitting design for ease of service.



**Used with
LC Series Controller**

- Complies with efficiency requirements of ASHRAE/IESNA 90.1-2013.
- Certified to ANSI/ARI Standard 390-2003 for SPVU (Single Package Vertical Units).
- Intertek ETL Listed to Standard for Safety Heating and Cooling Equipment ANSI/UL 1995/CSA 22.2 No. 236-05, Fourth Edition.
- Commercial Product - Not intended for Residential application.



Bard is an
ISO 9001:2008
Certified Manufacturer

Capacity and Efficiency Ratings — 1-Stage Compressors

MODELS	D36A D36L
Cooling Capacity BTUH ①	36,000
EER ②	11.5

① Capacity is certified in accordance with ANSI/ARI Standard 390-2003.

Rating conditions are 95°F (35°C) outdoor and 80°F DB/67°F WB (26.5°C / 19.5°C WB) return air.

② EER = Energy Efficiency Ratio (BTU / Watt Efficiency) is certified in accordance with ANSI/ARI Standard 390-2003. Includes DC watts for blower motor. Ratings are with no outside air. Performance will be affected by altitude.

Electrical Ratings — 1-Stage Compressor Models

MODELS	D36A2PA D36L2PA	D36A2PB D36L2PB
Electrical Rating – 60 Hz	230/208-1	230/208-3
Operating Voltage Range	253-197	
DC Electrical Rating ①	-48VDC	
Operating Voltage Range	40 - 60 VDC	
Compressor		
Voltage	230/208-1	230/208-3
Rated Load Amps	11.6 / 12.9	7.4 / 8.2
Branch Circuit Selection Current	16.7	10.5
Lock Rotor Amps	79	73
Fan Motor		
Fan Motor – HP	1/3	
Volts	230/208-60-1	
Full Load Amps	2.5	
Fan – CFM	2900	
DC Blower Motor		
Blower Motor – HP	3/4	
Volts ①	-48VDC	
Blower Motor – Full Load Amps	14.0	
Shipping Weight (Lbs.)	565	

① Neg. 48VDC positive ground.

Unit Charge Rates (R-410A)

UNIT	Std. Unit - Lbs.	Dehum. Units - Lbs.
D36A2P/D36L2P - DUAL-TEC™ -48VDC Right & Left Hand Free Cooling	9.375	N/A

DC Free Cooling Unit Ventilator

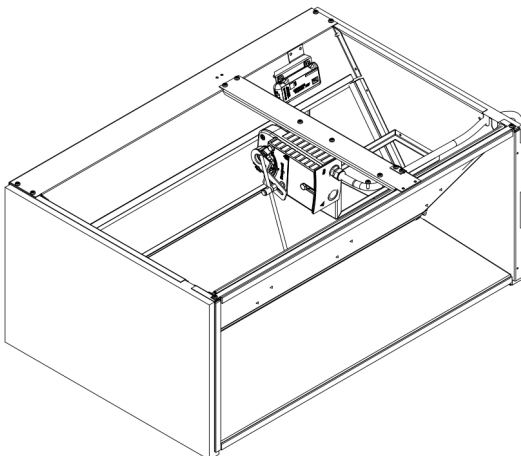

DC Powered Free Cooling Ventilator:

The DUAL-TEC™ free cooling ventilator allows for cooling operation when outdoor temperature conditions are acceptable outside the building structure. By using a modulating motor controlled by the PLC Logic Board, the ventilator allows for filtered outdoor air to enter the structure and provide cooling with minimal energy usage. The ventilator has the following features:

- Defaults to temperature only, with optional humidity sensing.
- Exhaust air passage maintain a slight positive indoor air pressure.
- Easily serviceable, modulating DC powered vent motor.
- Large air intake passages for increased efficiency.
- Advanced blade sealing for minimal air infiltration when closed.
- Intake air filter.
- Advanced PLC algorithmic operation.
- Outdoor air temperature and enthalpy sensor.
- Return air temperature sensor.

SUMMARY ELECTRICAL RATINGS

1-Stage Compressor Models

MODEL	Rated Volts, Hertz & Phase	AC Power Circuit			DC Positive Ground Power Circuit		
		Minimum Circuit Ampacity	Maximum External Fuse or Ckt. Brkr.	Field Power Wire Size	Minimum Circuit Ampacity	Maximum External Fuse or Ckt. Breaker	Field Power Wire Size
D36A2PA05 / D36L2PA05	208/230-60-1	26	40	8	15.6	20	12
D36A2PB06 / D36L2PB06	208/230-60-3	18	25	10	15.6	20	12

These "Minimum Circuit Ampacity" values are to be used for sizing the field power conductors. Refer to the National Electrical code (latest version), Article 310 for power conductor sizing.

Caution: When more than one field power circuit is run through one conduit, the conductors must be derated. Pay special attention to note 8 of Table 310 regarding Ampacity Adjustment Factors when more than three (3) current carrying conductors are in a raceway.

Maximum size of the time delay fuse or HACR type circuit breaker for protection of field wiring conductors.

Based on 75C copper wire. All wiring must conform to the National Electrical Code and all local codes.

IMPORTANT: While this electrical data is presented as a guide, it is important to electrically connect properly sized fuses & conductor wires in accordance with the National Electrical Code & all local codes.

Outdoor Sound Ratings — Cooling Mode

DISTANCE FROM HVAC UNIT	dB(A)
10 Feet	63.5
20 Feet	57.6
30 Feet	56.1

1. Values recorded in Bard Manufacturing Company, Inc. Sound Lab Facility.
2. Actual field results may vary with local conditions that can affect ambient background levels.

Cooling Application Data - Outdoor Temperature ①

Model	Return Air (DB/WB) ②	Cooling Capacity	75°F	80°F	85°F	90°F	95°F	100°F	105°F	110°F	115°F	120°F	125°F
D36A/L	75/62	Total Cooling	37,500	35,800	34,300	32,800	31,400	30,100	28,700	27,400	26,100	24,900	23,600
		Sensible Cooling	27,200	27,100	26,700	26,300	25,900	25,400	24,800	24,100	23,400	22,600	21,700
	80/67	Total Cooling	40,000	39,000	38,100	37,100	36,000	35,000	33,800	32,600	31,400	30,100	28,700
		Sensible Cooling	26,400	26,500	26,400	26,300	26,100	25,800	25,400	24,900	24,300	23,600	22,800
	85/72	Total Cooling	47,700	45,600	43,800	41,900	40,000	38,300	36,500	34,700	33,000	31,300	29,500
		Sensible Cooling	27,100	26,900	26,500	26,100	25,600	25,000	24,200	23,400	22,400	21,300	20,200
Capacity Multiplier Factors													
		% of Rated Airflow	-10	Rated	+10								
		Total BTUH	0.975	1.0	1.02								
		Sensible BTUH	0.950	1.0	1.05								

① Below 65°F (18.3C), unit requires a factory or field installed low ambient control.

② Return air temperature.

Indoor Blower Performance

MODEL	Rated ESP	MAX ESP	Free Cooling CFM above 40°	Free Cooling CFM below 40° ①	Mechanical Cooling CFM ②	Electric Heat Airflow
D36A/D36L	0.15	0.50	1800	800	1100	1800

① Free Cooling Logic uses this indoor motor speed at low outdoor temperatures. The damper actuator will then adjust to still yield a 55°F supply air temperature.

② Mechanical compressor cooling logic uses this indoor motor speed to achieve AHRI rated capacity and efficiency.

Factory Built-In Electric Heat Tables

Model	Voltage	Phase	KW		Amps		BTUH	
			240	208	240	208	240	208
-A05	240/208	1	5.00	3.75	20.8	18.0	17,065	12,799
-B06	240/208	3	6.00	4.50	14.4	12.5	20,478	15,359

LC2000 Dimensions and Weight

The LC2000-300 Controller must be used with the DUAL-TEC™ Series Wall Mount

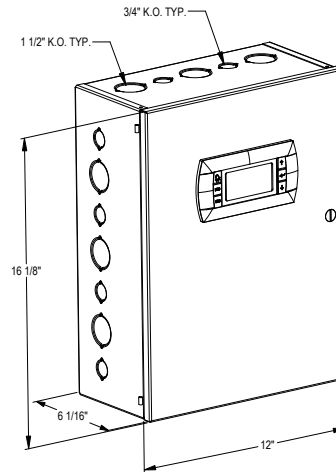

LC Controller Weight: 28 lbs.

MIS-3650

Part Number	Description	Included with LC2000
8301-055	EMI Ferrite Filter (1 needed for each unit connection to Controller)	2
8301-059	TEC-EYE (Service Tool), 5 ft. communication cable	1
8403-079	Remote Temperature and Humidity Sensor with 35' wire	1
8301-058	Remote Temperature Sensor (2 additional sensors may be used) with 35' wire *	Optional

* Additional Temperature Sensors may be added, but not additional Temperature/Humidity Sensors.

DUAL-TEC™ Unit Connectivity with LC2000 Controller

DUAL-TEC™ Connectivity Features:

The DUAL-TEC™ free cooling unit is made to work in conjunction with the LC2000 Series Controller. Up to two (2) DUAL-TEC™ units can be connected to the LC2000 controller using 2-wire twisted pair with drain. Each unit and the LC2000 controller contains an advanced PLC logic board for communication. The DUAL-TEC™ unit and LC2000 Controller have the following connectivity features:

- When used with the LC2000 controller, humidity levels inside the shelter can be monitored and outdoor air intake through the free unit cooling ventilator is closed when humidity levels are unacceptable.
- The DUAL TEC unit supply sensor allows temperature monitoring of conditioned and outdoor air entering the structure. By using the supply air temperature measured, the unit is able to supply cooling within the structure without extreme temperature variations.
- The DUAL TEC unit outdoor temperature sensor allows free cooling operation when outdoor ambient temperatures permit operation.

DUAL-TEC™ Unit #1

DUAL-TEC™ Unit #2
(Not required for operation)

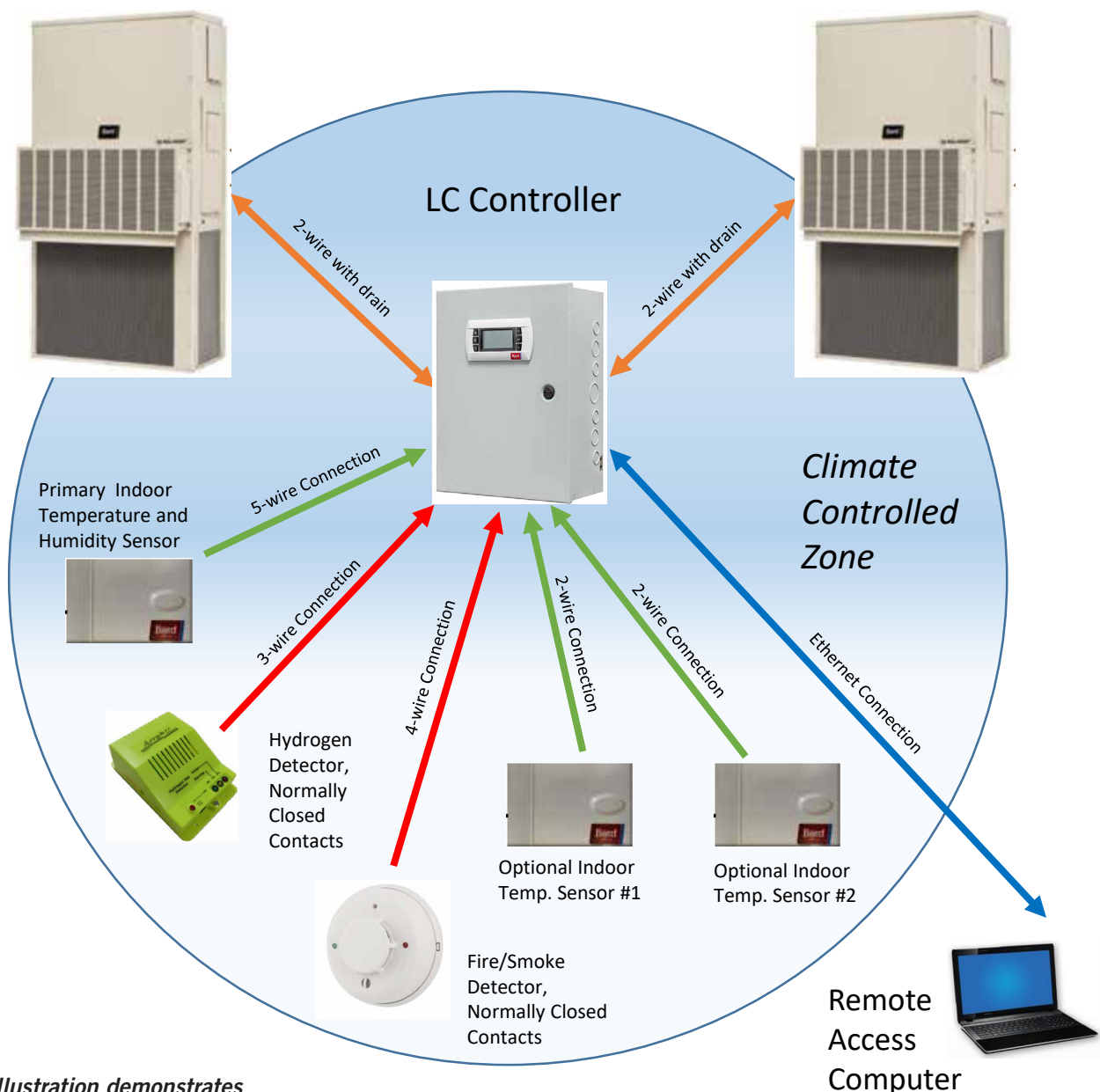

This illustration demonstrates connection of DUAL-TEC™ units and the LC2000 controller with optional sensors and equipment.

DUAL-TEC™ Unit in Orphan Mode

DUAL-TEC™ Orphan Mode Features:

The DUAL-TEC™ free cooling unit is made to function in “orphan mode” if connection to the LC controller is lost due to a severed connection wire or other system failure. When in orphan mode, the DUAL-TEC™ unit will continue to provide cooling to the structure until the connection can be restored. By using a return air temperature sensor measuring structure air temperature and a supply air temperature sensor to measure air provided to the structure, the unit is able to provide cooling. Orphan mode temperature set points are contained inside the DUAL-TEC™ PLC logic board. When connection of the DUAL-TEC™ unit is restored, the unit temperature set points will revert back to the temperature set points programmed into the LC controller.

DUAL-TEC™ Unit running in Orphan Mode

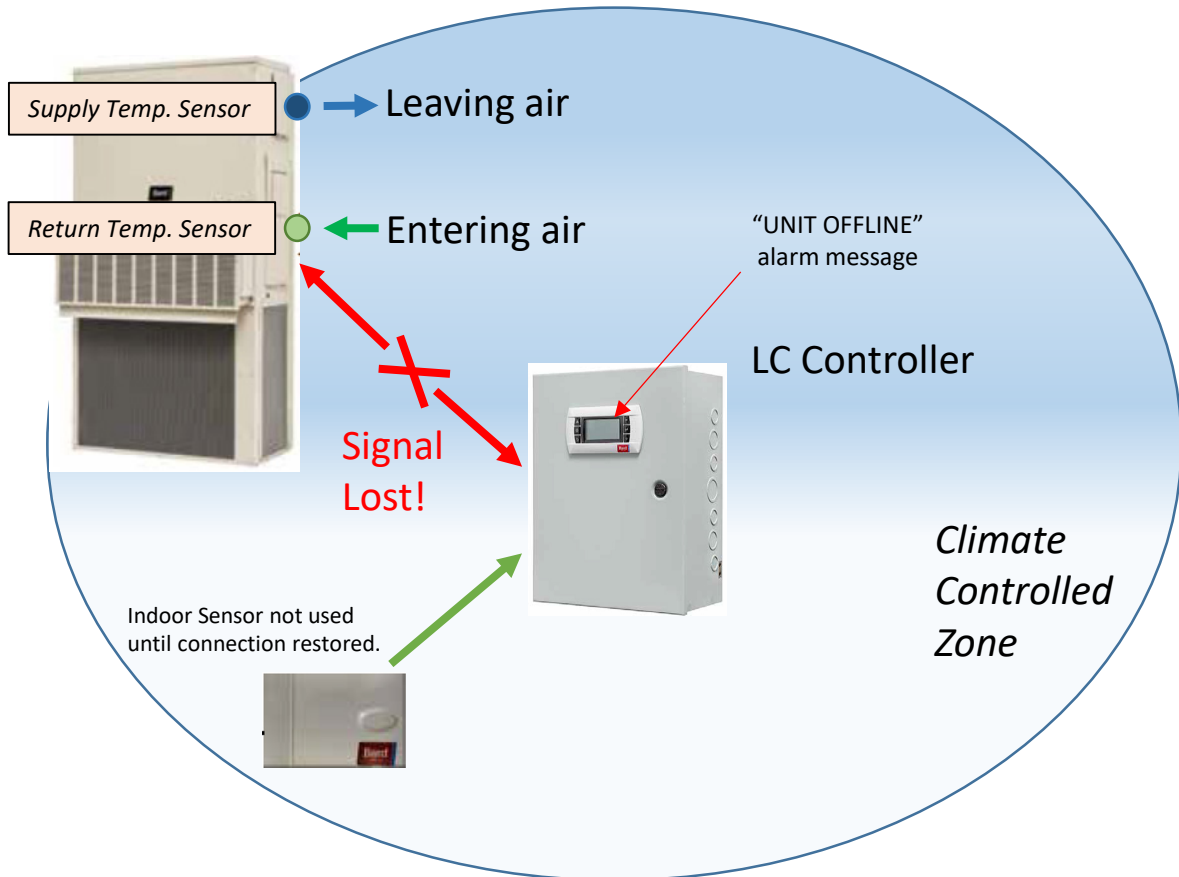

This illustration demonstrates Orphan Mode unit operation. If connection to the LC controller is lost for any reason, the unit will continue to operate using the return air sensor and supply air temperature sensors in the unit.

DUAL-TEC™ Unit in -48VDC Free Cooling Mode

DUAL-TEC™ -48VDC only Features:

The DUAL-TEC™ free cooling unit is made to function in “-48VDC Free Cooling Mode” if conditions outside the shelter are acceptable for cooling. The DUAL-TEC™ unit will attempt to maintain the set points programmed into the LC controller by bringing outside air into the shelter through the unit ventilator. By running the indoor blower and maintaining a consistent supply temperature by modulating the vent damper blade using -48VDC power supplied, the unit is able to provide cooling. Compressor operation is used to cool the shelter in conjunction with the -48VDC indoor blower and vent if outdoor air intake is inadequate to provide structure cooling. If outdoor ambient conditions reach a point that is unacceptable for cooling the structure, the vent damper blade closes, and the unit runs in “compressor only” cooling mode.

DUAL-TEC™ Unit running in -48 Free Cooling Mode

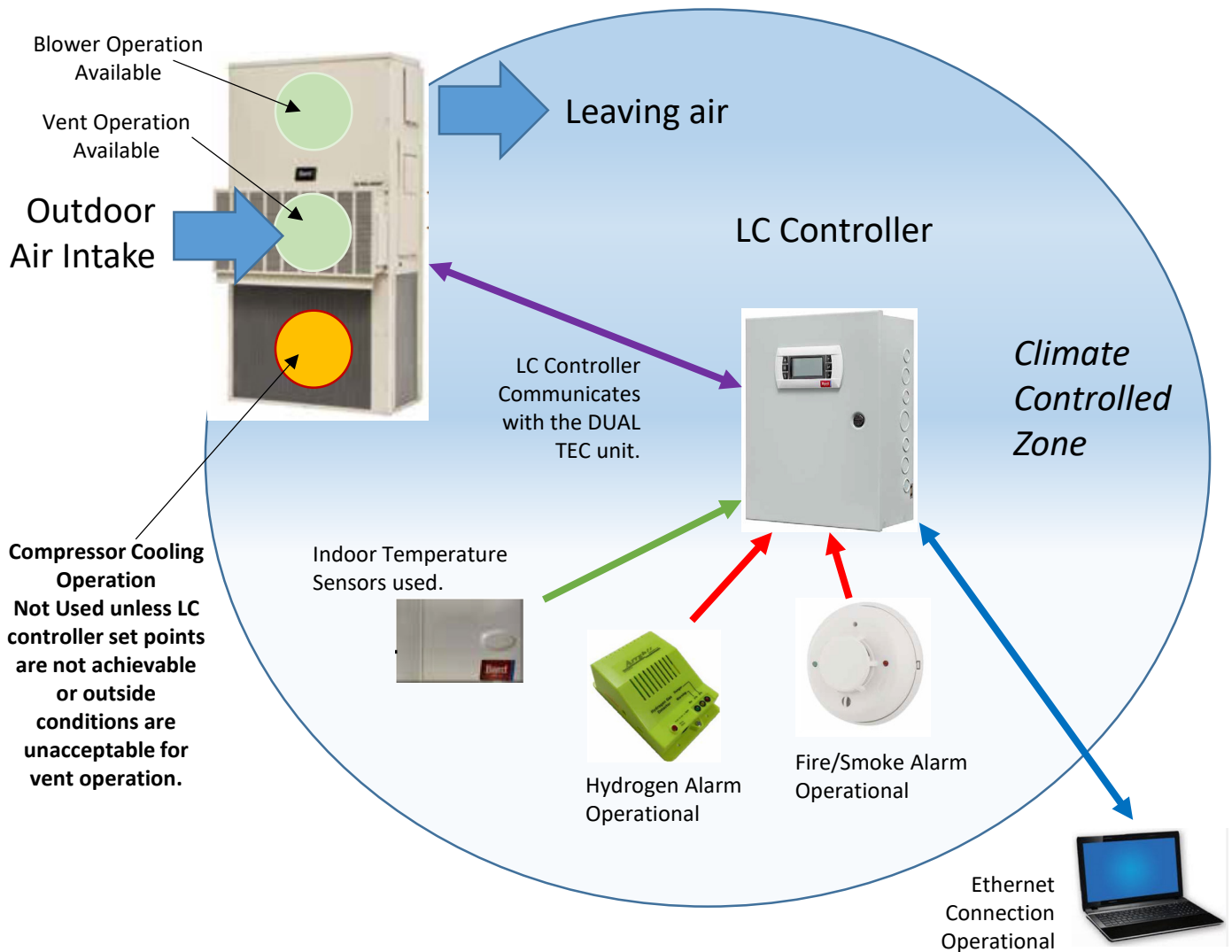

This illustration demonstrates -48VDC unit operation. The DUAL-TEC™ unit is able to bring outdoor air into the structure using the indoor blower and the free cooling ventilator. The LC controller is operational during -48VDC operation along with alarm functionality.

TEC-EYE™ DIAGNOSTIC TOOL FOR USE WITH DUAL-TEC™ UNITS

TEC-EYE™ Features:

The DUAL-TEC™ free cooling unit contains a PLC logic board located inside the unit control panel. The TEC-EYE™ tool, included with the LC2000 controller, allows for diagnostics and unit set point settings to be completed at the unit. This allows the user to complete various tasks outside where the units are located, and access to the inside controller is not needed for many tasks. Using an RJ11 modular phone connection and the cord provided with the TEC-EYE™, the service technician or contractor can run testing procedures or verify unit installation. Magnets on the back of the TEC-EYE™ allow for temporary mounting to the side of the DUAL-TEC™ unit while these tasks are being completed.

TEC-EYE™ Connection to DUAL-TEC™ Unit PLC Logic Board

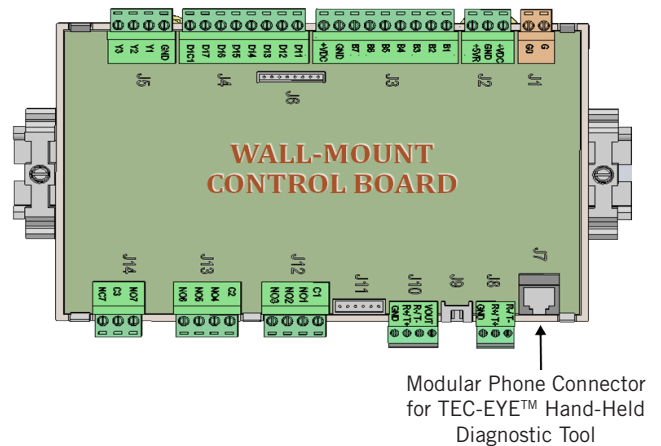

TEC-EYE™ Diagnostic Tool Part #8301-059



TEC-EYE™ Display



ALARM KEY

Allows viewing of active alarms
Silences audible alarms
Resets active alarms

MENU KEY

Allows entry to Main Menu

ESCAPE KEY

Returns to previous menu level
Cancels a changed entry

UP KEY

Steps to next screen in the display menu
Changes (increases) the value of a modifiable field

ENTER KEY

Accepts current value of a modifiable field
Advances cursor

DOWN KEY

Steps back to previous screen in the display menu
Changes (decreases) the value of a modifiable field

DUAL-TEC™ UNIT ALARMS

Alarm Features:

The DUAL-TEC™ free cooling unit is capable of sending and storing various unit alarms and contains the following alarm features:

- Low Refrigerant Pressure Alarm
- High Refrigerant Pressure Alarm
- Landline/Shore/Prime Power Outage
- Dirty Air Filter Alarm
- DC Free Cooling Damper Fails to Open Alarm
- DC Free Cooling Damper Fails to Close Alarm
- Communication Failed Alarm
- Supply Air Temperature Sensor Failed Alarm
- Outdoor Temperature Sensor Failed Alarm
- Outdoor Humidity Sensor Failed Alarm
- Return Air Temperature Sensor Failed Alarm

NOTE: See D-Series and LC2000 Installation Manual for Network, LC Controller and Shelter Alarms.

Dimensions of Basic Unit for Architectural and Installation Requirements (Nominal)

Model	Width (W)	Depth (D)	Height (H)	Supply		Return																
				A	B	C	B	E	F	G	I	J	K	L	M	N	O	P	Q	R	S	T
D36A/L	42.075	22.432	84.875	9.88	29.88	15.88	29.88	43.88	13.56	31.66	30.00	32.68	26.94	34.69	32.43	3.37	43.00	23.88	10.00	1.44	16.00	1.88

All dimensions are in inches. Dimensional drawings are not to scale.

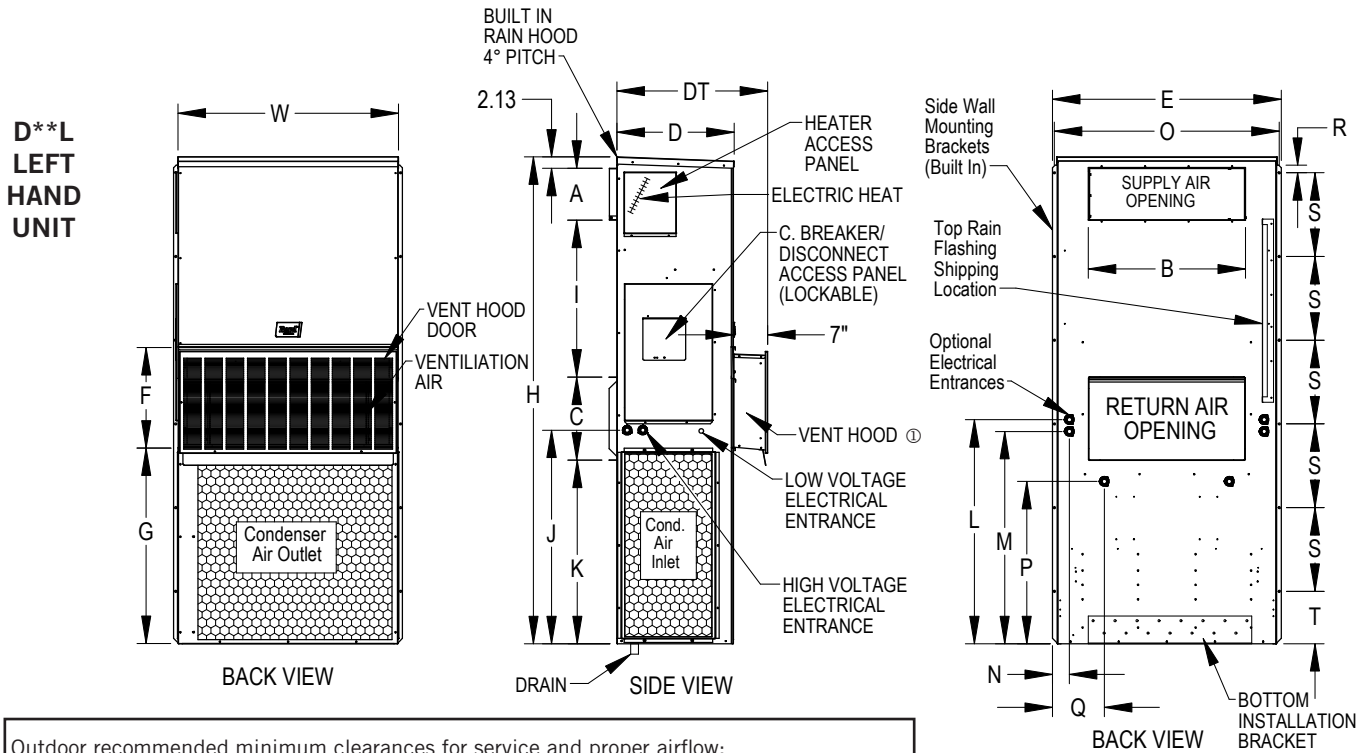
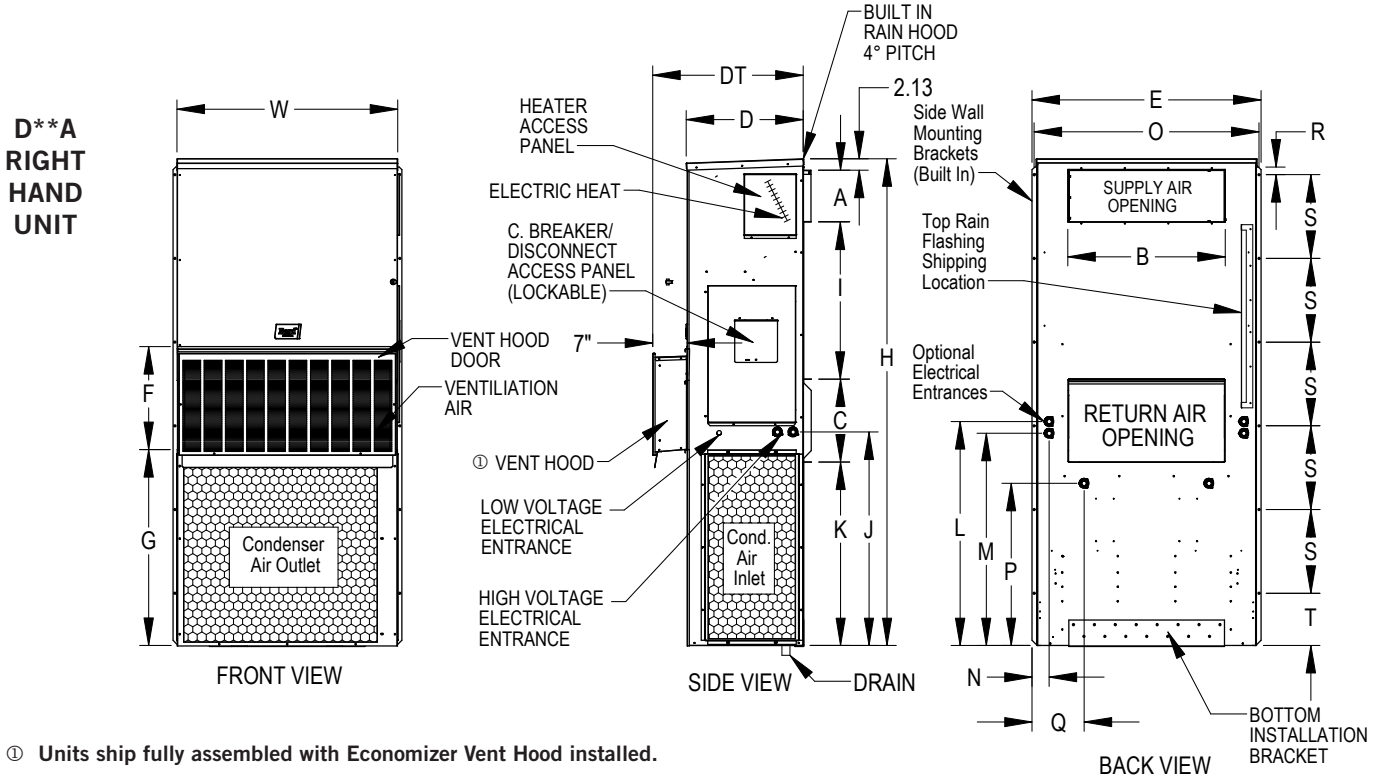

Outdoor recommended minimum clearances for service and proper airflow:
 Left Side 20 inches; Right Side 20 inches; Front Clearance to a solid barrier 15 feet

Indoor recommended minimum clearances to unit return is 24 inches. Supply must be able to freely distribute conditioned air through the structure for proper unit operation.

MIS-3618 A

Air Conditioning Wall-Mount Model Nomenclature 1-Stage Compressor Models

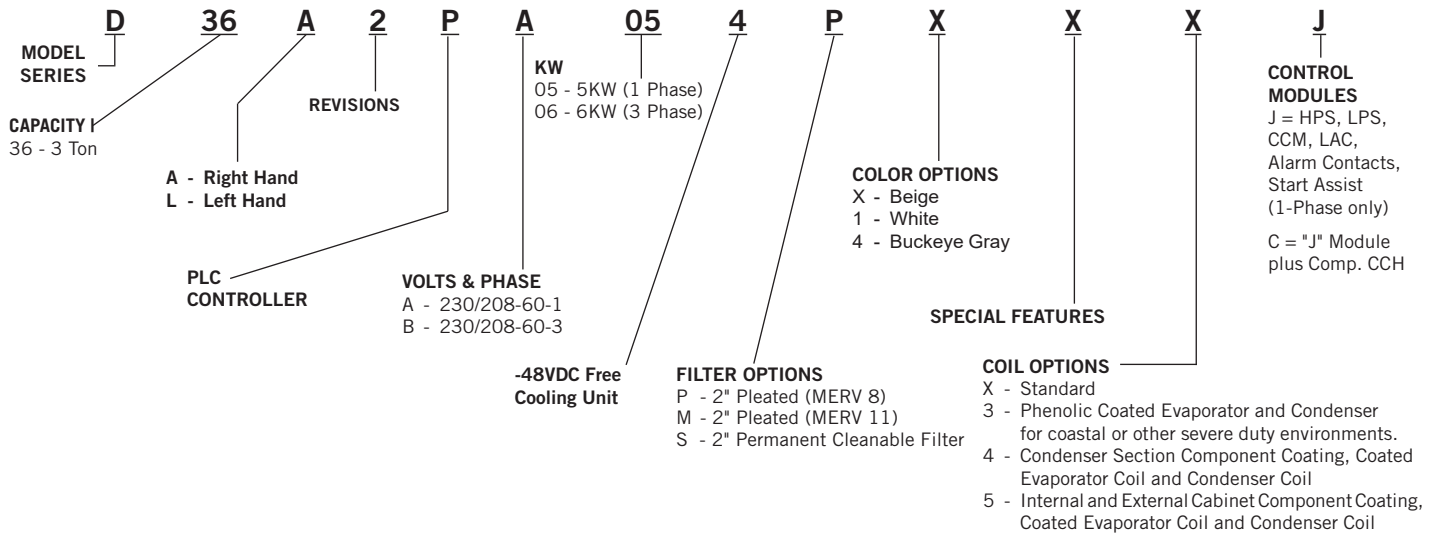

DUAL-TEC™ Standard Controls

High Pressure Switch: **Required Safety Device** that also provides protection to the compressor system when system refrigerant pressure is above an acceptable level. Auto Reset, 650 psig. Output to compressor control module.

Low Pressure Switch: Provides protection to the compressor when refrigerant pressure falls below an acceptable level. Auto Reset, cut out at 40 psig. Output to compressor control module.

Low Ambient Control: Modulating control that removes power from the condenser fan to allow for unit compressor cooling operation at outdoor ambient temperatures below 65°F. Factory set for system performance. Screw-on connection for easy servicing. Output to condenser fan motor.

Compressor Control Module: Compressor protection device that has a 30-second to 5-minute timer. This module features a delay-on-make for initial startup for a minimum of 2 minutes plus 10% of the timer setting. There is no delay during routine operation. Allows one automatic retry after high pressure switch activation, then goes into hard lockout mode. Output to PLC logic board.

Start Assist (Single Phase Models Only): PTCR motor starting device increases compressor motor torque 2-3 times.

Supply Air Sensor: 10K Thermistor measures supply air temperature, output to PLC logic board.

Return Air Sensor: 10K Thermistor measures return air temperature, output to PLC logic board.

Evaporator Coil Sensor: 10K Thermistor prevents coil freezing due to low return air temperature. Output to PLC logic board.

Outdoor Temperature & Enthalpy Sensor: 10K Temperature sensor and 4-20mA humidity transmitter, output to PLC logic board (PLC defaults to temperature only).

Phase Monitor (3-Phase Models Only): Prevents 3-phase compressor operation to protect the compressor if the device senses incorrect phasing. LED indicator light.

Filter Switch: Adjustable switch to indicate the unit air filter needs to be replaced. Output to PLC logic board.

DUAL-TEC™ Optional Controls

Compressor Crankcase Heater: 2-wire heater that prevents refrigerant migration and mixing with crankcase oil when the unit is off, prevents condensation of refrigerant in the crankcase of the compressor, and keeps refrigerant at a temperature higher than the coldest part of the system. [Recommended for Canada and cold climate compressor operation.](#)



Bard Manufacturing Company, Inc.
Bryan, Ohio 43506
www.bardhvac.com

Due to our continuous product improvement policy, all specifications subject to change without notice.

Before purchasing this appliance, read important energy cost and efficiency information available from your retailer.

**Form No.
S3521
December 2017**

Supersedes: S3521-516