

Bard Shipping Crate Specification Sheet and Part Number Matrix

Bard offers additional shipping protection through the use of a shipping crate. Specified at the time the product is ordered, it offers additional protection against cabinet scratches, corner impact and panel damage.

The crate is comprised of 7/16" OSB board and galvanized steel angles around the existing unit packaging. Existing unit packaging helps absorb impacts normally associated with shipping products.

Crate Features

Features of the Shipping Crate:

- Steel corners for additional corner impact protection.
- OSB sheathing construction for additional scratch protection.
- Sized for truck transportation.
- Forklift openings in skid.
- Treated for pests in accordance with the International Plant Protection Convention, Publication 15, Annex 1. Packaging is acceptable for international shipments.

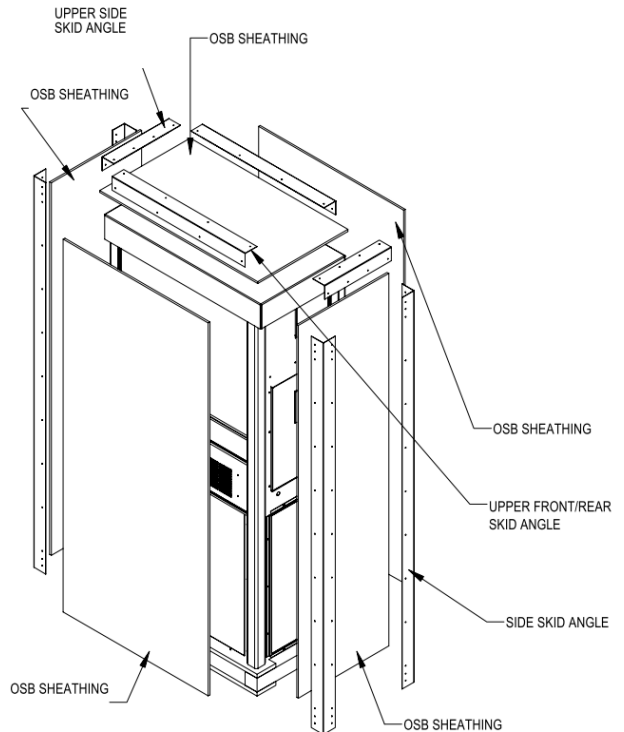

Crate Sizes & Weights

Crate Overall Dimensions & Additional Shipping Weights:				
Crate Part #	Height	Width	Depth	Weight
8620-232	76.5	43	22.5	124
8620-234	90.5	47	27.5	170
8620-250	100.5	47	27.5	220
8620-262	80.5	43	22.5	132
8620-263	80.5	38	22.5	105
8620-275	80.0	37	28.5	150
8620-276	80.0	42	28.5	104.5
8620-304	90.0	46	29.5	165
8620-305	99.0	46	29.5	226
8620-355	87.5	42.0	28.5	150
8620-356	93.5	47.0	33.0	184

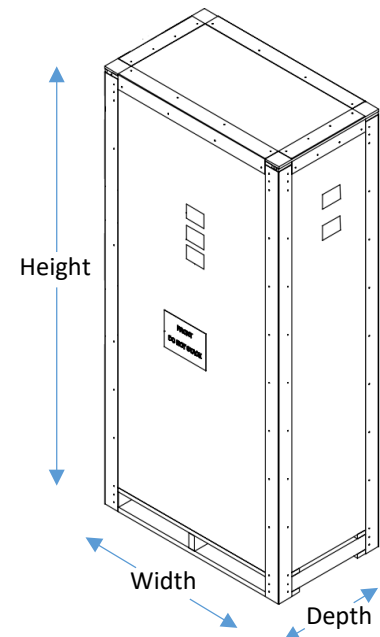

REMINDER: Always inspect unit for shipping damage when product is received by disassembling crate. This will help identify possible damage before signing documentation provided by shipper.

Shipping Crate Part Number Matrix

Unit	Ventilation Option	Shipping Crate	Notes	
W18*Y - WA, WH, MULT-TEC	X, A, B, M, V, R	8620-263	Ventilation options with hoods are factory installed.	
W24*Y - WA, WH, MULT-TEC				
W18*Y - WA, WH, MULT-TEC	D, Y, Z	8620-275		
W24*Y - WA, WH, MULT-TEC				
W30*Y - WA, WH, MULT-TEC	X, A, B, M, V, R	8620-262		
W36*Y - WA, WH, MULT-TEC				
W30*Y - WA, WH, MULT-TEC	D, Y, Z	8620-276		
W36*Y - WA, WH, MULT-TEC				
W42*Y - WA, WH, MULT-TEC	All	8620-304	No hood required for ventilation options.	
W48*Y - WA, WH, MULT-TEC				
W60*Y - WA, WH, MULT-TEC				
W72*Y - WA, WH, MULT-TEC				
W3SAC	All	8620-304		
W4SAC				
W5SAC				
C24H2	All	8620-232		Ventilation options wth hoods are field installed.
C30H2				
C36HY	All	8620-304	No hoods required for ventilation options.	
C42HY				
C48HY				
C60HY				
W24G	All	8620-355		Ventilation options with hoods are field installed.
W30G				
W36G				
W42G	All	8620-356		
W48G				
W60G				
T30S				
T36S	All	8620-232		
T42S				
T48S				
T60S	All	8620-250		
W6*V				
W3VHY	All	8620-304	No hood required for ventilation options.	
W5VHY				
W12A	No Crate Available			
HR, FUSION-TEC	No Crate Available			
WR, FUSION-TEC	No Crate Available			
W090, W120, W150, W180 MEGA-TEC	Crate is ordered as a unit option.			