



# DUAL-TEC™ WALL-MOUNT™ Air Conditioners with -48VDC Blower Motor DC Voltage 100% Free Cooling Unit (50 Hz)

## D35A2/D35L2 1-Stage Right & Left-Hand Control Panel

## GREEN REFRIGERANT R-410A

The Bard DUAL-TEC™ Wall Mount™ Air Conditioners with -48VDC Blower Motor and DC Voltage Free Cooling Economizer are designed for maximum indoor cooling at the most efficient operating cost for year-round operation in the demanding equipment shelter environment. D25 & D35 Models are sized to replace existing 3-Ton wall mount air conditioners.

The DUAL-TEC™ units operate on both AC and -48VDC positive ground power under normal power supply conditions. If there is loss of AC power supply (shore &/or back-up generator) the DUAL-TEC™ will continue to operate as free-cooling or ventilation system using the shelter's DC power. The DUAL-TEC™ indoor blower and economizer operate from -48VDC and no inverter is required.

The DUAL-TEC™ units will supply up to 100% of rated cooling airflow in free cooling mode with the ability to exhaust the same amount through the unit itself without any additional relief openings in the shelter.

### DUAL-TEC™ Special Features

#### Brushless -48VDC Indoor Blower Motor:

Features low sound levels and soft-start capabilities. Soft start function helps to ensure DC power levels will not decrease on start up, and brushless design ensures low DC power noise. The motor is self-adjusting to provide the proper airflow rate without user adjustment or wiring changes.

#### DC Polarity Monitor:

Includes diagnostics and protects critical DC components against reverse polarity and out-of-range DC power. Range is 40-60 VDC.

#### Remote Monitoring:

Bard-Link™ web interface with use of LC Controller.

#### 100% Free Cooling Unit Ventilator:

All units are equipped with a full-flow free cooling ventilator. The ventilator uses DC power for operation in conjunction with the -48VDC Indoor Blower during AC power loss. Modulating air intake allows precision temperature control inside the structure while maximizing energy savings.

#### PLC Logic Board:

All units are equipped with a PLC Logic Board for advanced unit operation and alarm capability. The PLC Logic Board allows for "orphan mode" unit operation if communication with the LC controller is lost.



Bard DUAL-TEC™

### Standard Engineered Features — All Models

#### Copper Tube / Aluminum Fin Coils:

Grooved copper tubing and enhanced aluminum fins provide maximum heat transfer and high energy efficiency. Optional phenolic-coated coils are also available.

#### Air Conditioner Compressor:

Scroll compressors are designed for increased efficiency, quieter operation and improved reliability for longer life.

#### R-410A Refrigerant:

Designed with R-410A (HFC) non-ozone depleting refrigerant in compliance with the Montreal protocol and 2010 EPA requirements.

#### PTCR Motor Starting Device:

Standard on 1-phase models, increases compressor motor starting torque 2-3 times. Optional factory or field installed hard start kit available, replaces PTCR device.

#### Galvanized 20 Gauge Zinc Coated Steel Cabinet:

Cleaned, rinsed, sealed and dried before the polyurethane primer is applied. The cabinet is handsomely finished with a baked on textured

enamel, which allows it to withstand 1000 hours of salt spray tests per ASTM B117-03. Condenser section and entire cabinet coatings are also available.

#### Foil Faced Insulation:

Standard on all units.

#### Full Length Mounting Brackets:

Built into cabinet for improved appearance and easy installation.

**NOTE:** Bottom mounting bracket included to assist in installation.

#### Liquid Line Filter Drier:

Standard on all units. Protects system against moisture.

#### 24V Transformer:

75VA with circuit breaker.

#### Electric Heat Strips:

Features an automatic limit and thermal cut-off safety control. Heater packages are factory installed options for all models.

#### Two-Inch, MERV 8 Air Filters:

Are standard equipment. All models include tight-sealing U-channel filter bracket to minimize air bypass around

the filter.

#### Built-In Circuit Breakers:

HACR-type circuit breakers are standard for AC power supply, and DC rated circuit breaker used for -48VDC power circuit.

#### High & Low Pressure Switches are Auto-Reset:

Standard on all units. Built-in lock-out circuit resets from the shelter Bard-Link™ Controller. Provides commercial quality protection to the compressor.

#### Refrigerant Sight Glass:

Standard on all units.

#### Low Ambient Control:

Modulating LAC standard on all models. Screw-on fitting design for ease of service.



Used with  
LC Series Controller



Intertek

Bard is an  
ISO 9001:2008  
Certified Manufacturer

- Complies with efficiency requirements of ASHRAE/IESNA 90.1-2013.
- Intertek ETL Listed to Standard for Safety Heating and Cooling Equipment ANSI/UL 1995/CSA 22.2 No. 236-05, Fourth Edition.
- Commercial Product - Not intended for Residential application.

## Capacity and Efficiency Ratings — 1-Stage Compressors

MODELS	D35A D35L
Cooling Capacity BTUH ①	36,000
EER ②	10.00

① Rating conditions are 95°F (35°C) outdoor and 80°F DB/67°F WB (26.5°C / 19.5°C WB) return air.

② EER = Energy Efficiency Ratio (BTU / Watt Efficiency) includes DC watts for blower motor. Ratings are with no outside air. Performance will be affected by altitude.

## Electrical Ratings — 1-Stage Compressor Models

MODELS	D35A2PD D35L2PD	D35A2PE D35L2PE
<b>Electrical Rating – 50 Hz</b>	240/220-1	220/200-3
Operating Voltage Range		197-253
DC Electrical Rating ①		-48VDC
Operating Voltage Range		40 - 60 VDC
<b>Compressor</b>		
Voltage	240/220-1	220/200-3
Rated Load Amps	15.9 / 17.6	11.8 / 13.0
Branch Circuit Selection Current	18.0	13.3
Lock Rotor Amps	112 / 112	88 / 88
<b>Fan Motor</b>		
Fan Motor – HP		1/3
Volts		240/220-50-1
Full Load Amps		2.5
Fan – CFM		2200
<b>DC Blower Motor</b>		
Blower Motor – HP		3/4
Volts ①		-48VDC
Blower Motor – Full Load Amps		14.0
<b>Shipping Weight (Lbs.)</b>		375

① Neg. 48VDC positive ground.

## Unit Charge Rates - R410-A

UNIT	Std. Unit - Lbs.
D35A2P/D35L2P - DUAL-TEC™ -48VDC Right & Left Hand Free Cooling	4.50

## DC Free Cooling Unit Ventilator

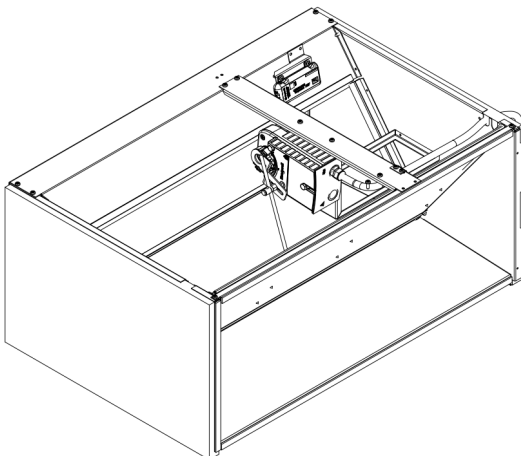

### DC Powered Free Cooling Ventilator:

The DUAL-TEC™ free cooling ventilator allows for cooling operation when outdoor temperature conditions are acceptable outside the building structure. By using a modulating motor controlled by the PLC Logic Board, the ventilator allows for filtered outdoor air to enter the structure and warm air to exit the structure to provide cooling with minimal energy usage. The ventilator has the following features:

- Defaults to temperature only, with optional humidity sensing.
- Exhaust air passage maintain a slight positive indoor air pressure.
- Easily serviceable, modulating DC powered vent motor.
- Large air intake and exhaust passages for increased efficiency.
- Advanced blade sealing for minimal air infiltration when closed.
- Intake air filter.
- Advanced PLC algorithmic operation.
- Outdoor air temperature and enthalpy sensor.
- Return air temperature sensor.

## SUMMARY ELECTRICAL RATINGS

### 1-Stage Compressor Models

MODEL	Rated Volts, Hertz & Phase	AC Power Circuit			DC Positive Ground Power Circuit		
		Minimum Circuit Ampacity	Maximum External Fuse or Ckt. Brkr.	Field Power Wire Size	Minimum Circuit Ampacity	Maximum External Fuse or Ckt. Breaker	Field Power Wire Size
D35A2PD0Z / D35L2PD0Z	240/220-50-1	24	40	8	15.6	20	12
D35A2PD05 / D35L2PD05	240/220-50-1	26	40	8	15.6	20	12
D35A2PE0Z / D35L2PE0Z	240/220-50-3	19	25	10	15.6	20	12
D35A2PE06 / D35L2PE06	240/220-50-3	19	25	10	15.6	20	12

These "Minimum Circuit Ampacity" values are to be used for sizing the field power conductors. Refer to the National Electrical code (latest version), Article 310 for power conductor sizing.

**Caution:** When more than one field power circuit is run through one conduit, the conductors must be derated. Pay special attention to note 8 of Table 310 regarding Ampacity Adjustment Factors when more than three (3) current carrying conductors are in a raceway.

Maximum size of the time delay fuse or HACR type circuit breaker for protection of field wiring conductors.

Based on 75C copper wire. All wiring must conform to the National Electrical Code and all local codes.

**IMPORTANT:** While this electrical data is presented as a guide, it is important to electrically connect properly sized fuses & conductor wires in accordance with the National Electrical Code & all local codes.

### Cooling Application Data - Outdoor Temperature <sup>①</sup>

Model	Return Air (DB/WB) <sup>②</sup>	Cooling Capacity	75°F	80°F	85°F	90°F	95°F	100°F	105°F	110°F	115°F	120°F	125°F
D35A/L	75/62	Total Cooling	35,200	33,400	32,000	30,400	28,900	27,500	26,300	25,100	23,900	22,800	21,700
		Sensible Cooling	26,100	25,400	24,900	24,300	23,600	23,000	22,300	21,700	21,100	20,400	19,800
	80/67	Total Cooling	37,500	36,400	35,400	34,400	36,000	32,100	31,000	29,900	28,700	27,600	26,400
		Sensible Cooling	25,300	24,900	24,600	24,300	23,800	23,300	22,900	22,400	21,900	21,300	20,800
	85/72	Total Cooling	44,700	42,600	40,700	38,800	36,900	35,100	33,400	31,800	30,200	28,700	27,300
		Sensible Cooling	25,900	25,300	24,800	24,100	23,300	22,600	21,800	21,100	20,200	19,300	18,400
<b>Capacity Multiplier Factors</b>													
<b>% of Rated Airflow</b>											-10	Rated	+10
<b>Total BTUH</b>											0.975	1.0	1.02
<b>Sensible BTUH</b>											0.950	1.0	1.05

① Outdoor temperatures shown are measured at the condenser section air inlet.

② Return air temperature (air entering unit).

### Outdoor Sound Ratings — Cooling Mode

DISTANCE FROM HVAC UNIT	dBA
3 Feet	72.1
5 Feet	69.4
10 Feet	67.1

1. Values recorded in Bard Manufacturing Company, Inc. Sound Lab Facility.

2. Actual field results may vary with local conditions that can affect ambient background levels.

## Indoor Blower Performance

MODEL	Rated ESP	MAX ESP	Free Cooling CFM above 40°	Free Cooling CFM below 40° ①	Rated Full Load Cooling CFM	Electric Heat Airflow
D35A/D35L	0.15	0.50	1800	800	1100	1800

① Free Cooling Logic Control derives at this decision point, and switches the indoor motor speed. The damper actuator will then adjust to still yield a 55°F supply air temperature.

## Factory Built-In Electric Heat Tables

Model	Voltage	Phase	KW		Amps		BTUH	
			240	208	240	208	240	208
-A05	240/208	1	5.00	3.75	20.8	18.0	17,065	12,799
-B06	240/208	3	6.00	4.50	14.4	12.5	20,478	15,359

## LC2000 Dimensions and Weight

The LC2000-200 Controller must be used with the DUAL-TEC™ Series Wall Mount

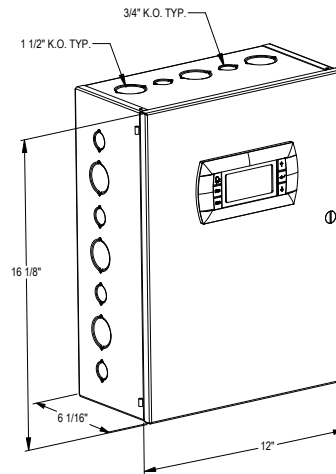

LC Controller Weight: 28 lbs.

MIS-3650

Part Number	Description	Included with LC2000
8301-055	EMI Ferrite Filter (1 needed for each unit connection to Controller)	2
8301-059	TEC-EYE (Service Tool), 5 ft. communication cable	1
8403-079	Remote Temperature and Humidity Sensor with 35' wire	1
8301-058	Remote Temperature Sensor (2 additional sensors may be used) with 35' wire *	Optional

\* Additional Temperature Sensors may be added, but not additional Temperature/Humidity Sensors.

# DUAL-TEC™ Unit Connectivity with LC2000 Controller

## DUAL-TEC™ Connectivity Features:

The DUAL-TEC™ free cooling unit is made to work in conjunction with the LC2000 Series Controller. Up to two (2) DUAL-TEC™ units can be connected to the LC2000 controller using 2-wire twisted pair with drain. Each unit and the LC2000 controller contains an advanced PLC logic board for communication. The DUAL-TEC™ unit and LC2000 Controller have the following connectivity features:

- When used with the LC2000 controller, humidity levels inside the shelter can be monitored and outdoor air intake through the free unit cooling ventilator is closed when humidity levels are unacceptable.
- The DUAL TEC unit supply sensor allows temperature monitoring of conditioned and outdoor air entering the structure. By using the supply air temperature measured, the unit is able to supply cooling within the structure without extreme temperature variations.
- The DUAL TEC unit outdoor temperature sensor allows free cooling operation when outdoor ambient temperatures permit operation.

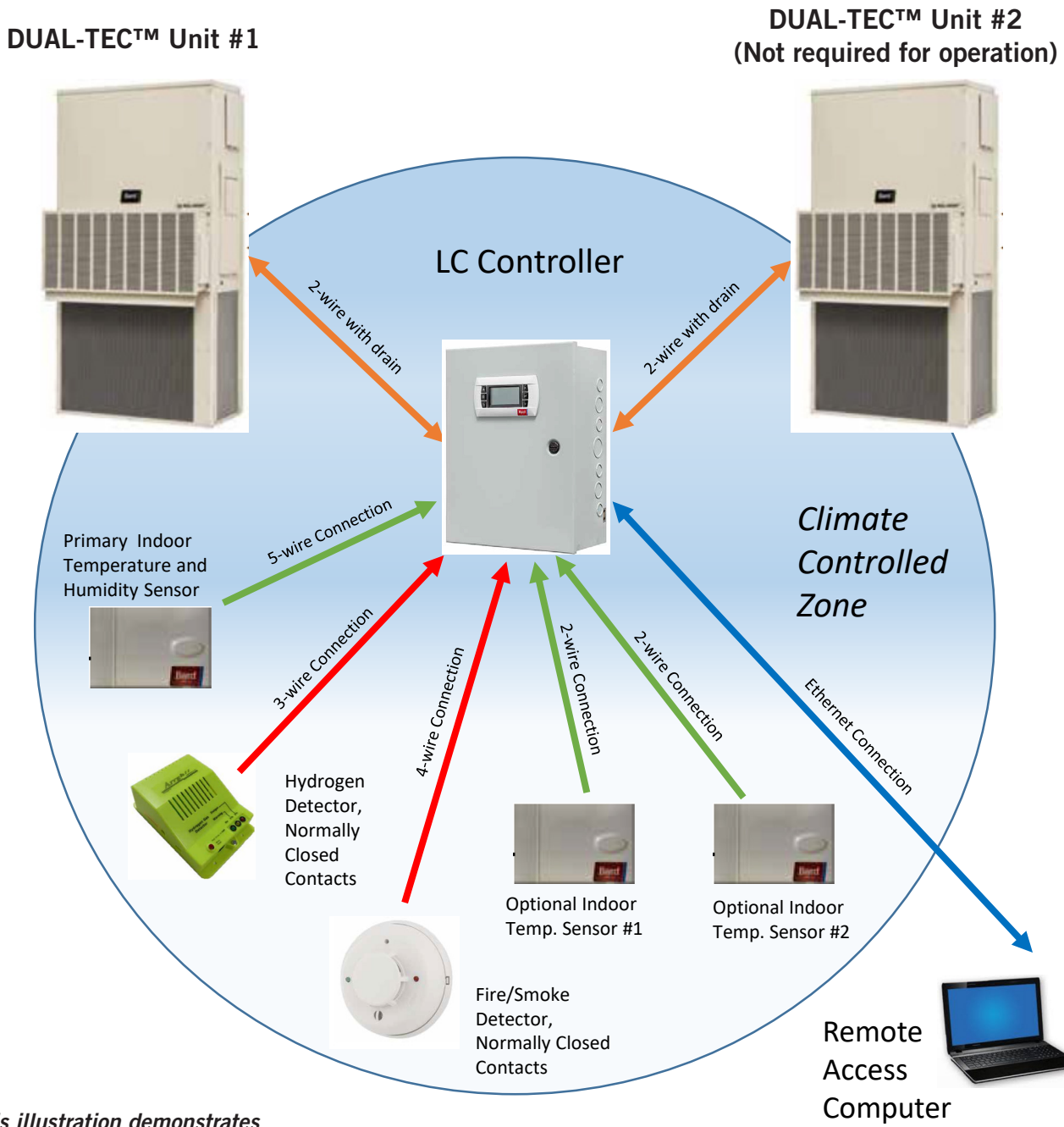

*This illustration demonstrates connection of DUAL-TEC™ units and the LC2000 controller with optional sensors and equipment.*

## DUAL-TEC™ Unit in Orphan Mode

### DUAL-TEC™ Orphan Mode Features:

The DUAL-TEC™ free cooling unit is made to function in “orphan mode” if connection to the LC controller is lost due to a severed connection wire or other system failure. When in orphan mode, the DUAL-TEC™ unit will continue to provide cooling to the structure until the connection can be restored. By using a return air temperature sensor measuring structure air temperature and a supply air temperature sensor to measure air provided to the structure, the unit is able to provide cooling. Orphan mode temperature set points are contained inside the DUAL-TEC™ PLC logic board. When connection of the DUAL-TEC™ unit is restored, the unit temperature set points will revert back to the temperature set points programmed into the LC controller.

### DUAL-TEC™ Unit running in Orphan Mode

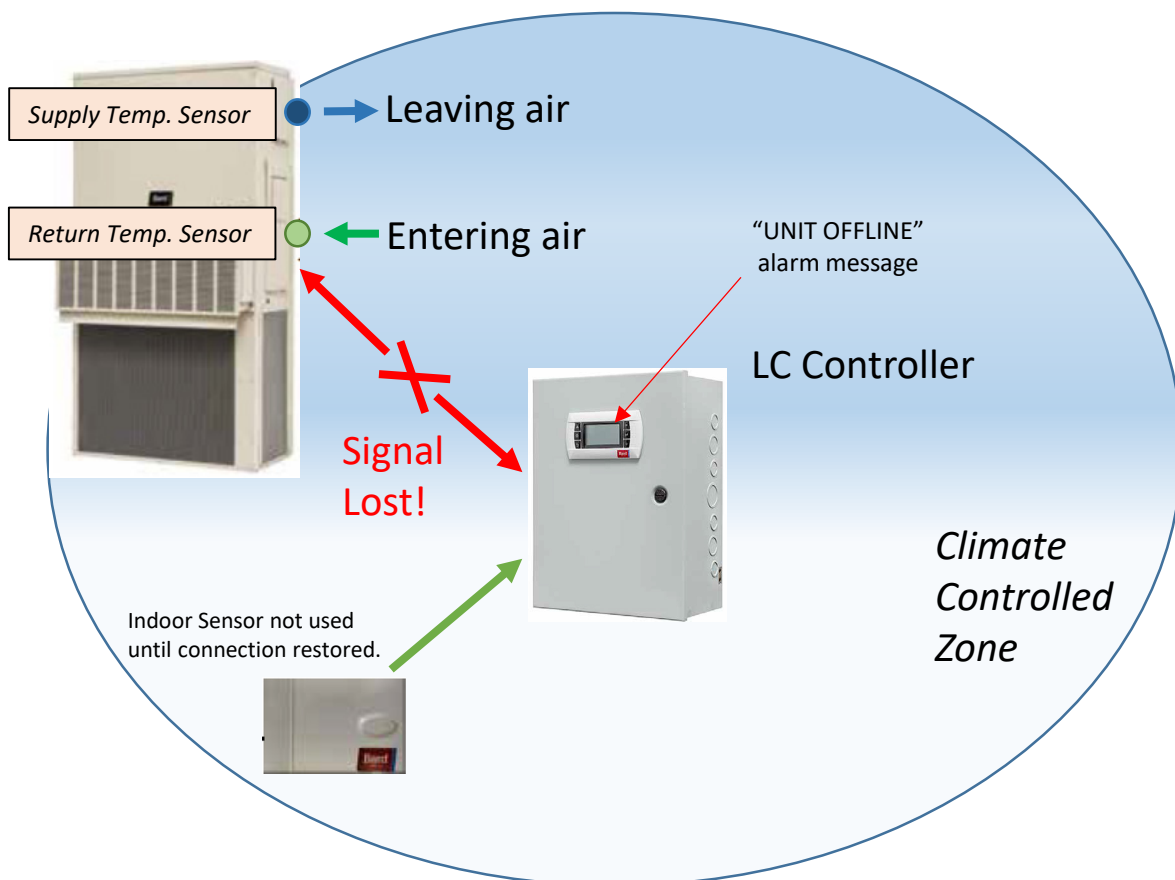

*This illustration demonstrates Orphan Mode unit operation. If connection to the LC controller is lost for any reason, the unit will continue to operate using the return air sensor and supply air temperature sensors in the unit.*

## DUAL-TEC™ Unit in -48VDC Free Cooling Mode

### DUAL-TEC™ -48VDC only Features:

The DUAL-TEC™ free cooling unit is made to function in “-48VDC Free Cooling Mode” if conditions outside the shelter are acceptable for cooling. The DUAL-TEC™ unit will attempt to maintain the set points programmed into the LC controller by bringing outside air into the shelter through the unit ventilator. By running the indoor blower and maintaining a consistent supply temperature by modulating the vent damper blade using -48VDC power supplied, the unit is able to provide cooling. Compressor operation is used to cool the shelter in conjunction with the -48VDC indoor blower and vent if outdoor air intake is inadequate to provide structure cooling. If outdoor ambient conditions reach a point that is unacceptable for cooling the structure, the vent damper blade closes, and the unit runs in “compressor only” cooling mode.

### DUAL-TEC™ Unit running in -48 Free Cooling Mode

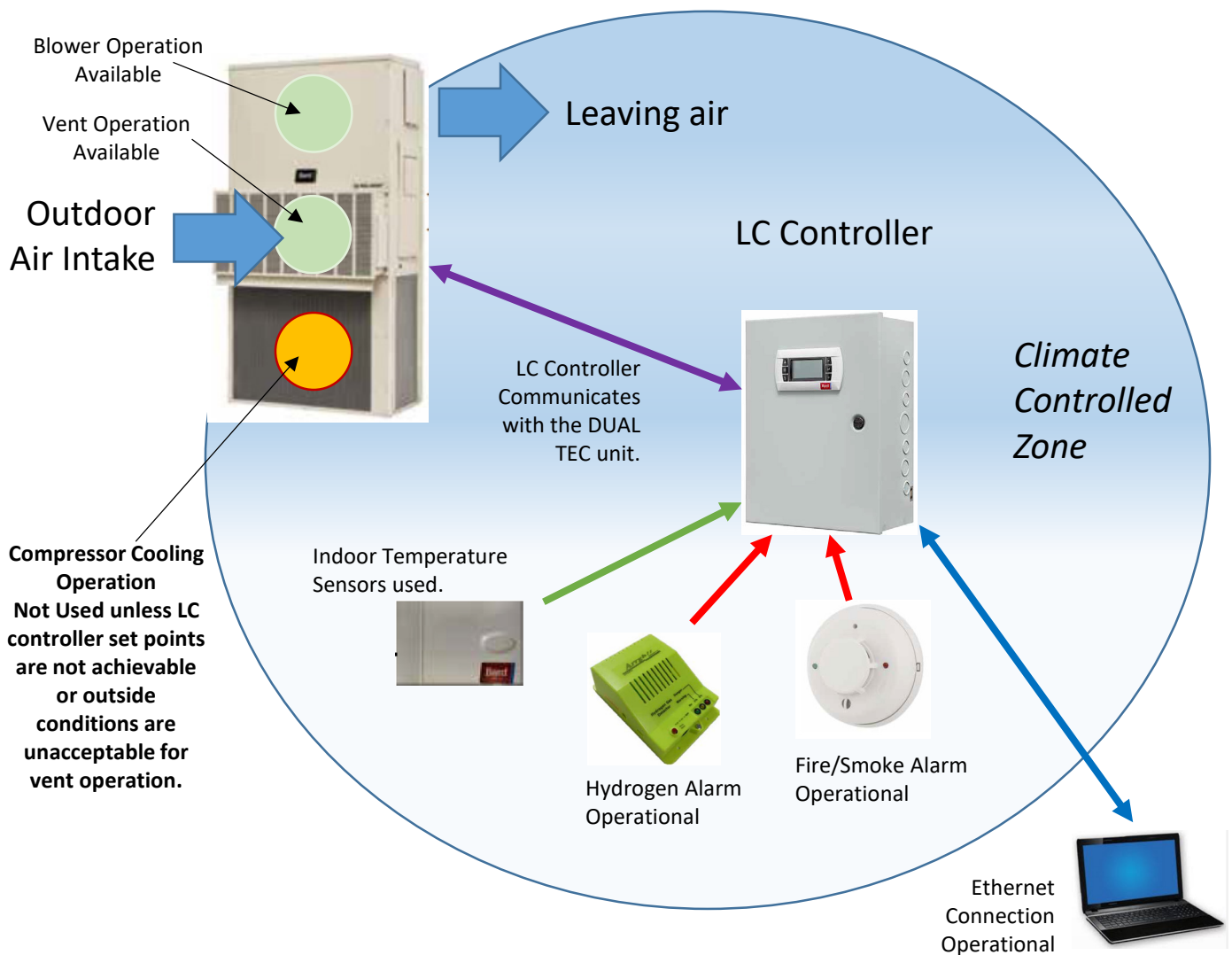

*This illustration demonstrates -48VDC unit operation. The DUAL-TEC™ unit is able to bring outdoor air into the structure using the indoor blower and the free cooling ventilator. The LC controller is operational during -48VDC operation along with alarm functionality.*

## TEC-EYE™ DIAGNOSTIC TOOL FOR USE WITH DUAL-TEC™ UNITS

### TEC-EYE™ Features:

The DUAL-TEC™ free cooling unit contains a PLC logic board located inside the unit control panel. The TEC-EYE™ tool, included with the LC2000 controller, allows for diagnostics and unit set point settings to be completed at the unit. This allows the user to complete various tasks outside where the units are located, and access to the inside controller is not needed for many tasks. Using an RJ11 modular phone connection and the cord provided with the TEC-EYE™, the service technician or contractor can run testing procedures or verify unit installation. Magnets on the back of the TEC-EYE™ allow for temporary mounting to the side of the DUAL-TEC™ unit while these tasks are being completed.

### TEC-EYE™ Connection to DUAL-TEC™ Unit PLC Logic Board

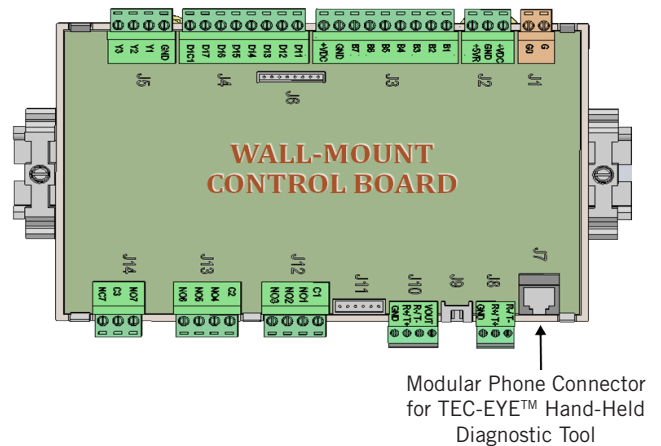

### TEC-EYE™ Diagnostic Tool Part #8301-059



### TEC-EYE™ Display



#### ALARM KEY

Allows viewing of active alarms  
Silences audible alarms  
Resets active alarms

#### MENU KEY

Allows entry to Main Menu

#### ESCAPE KEY

Returns to previous menu level  
Cancels a changed entry

#### UP KEY

Steps to next screen in the display menu  
Changes (increases) the value of a modifiable field

#### ENTER KEY

Accepts current value of a modifiable field  
Advances cursor

#### DOWN KEY

Steps back to previous screen in the display menu  
Changes (decreases) the value of a modifiable field

## DUAL-TEC™ UNIT ALARMS

### Alarm Features:

The DUAL-TEC™ free cooling unit is capable of sending and storing various unit alarms and contains the following alarm features:

- Low Refrigerant Pressure Alarm
- High Refrigerant Pressure Alarm
- Landline/Shore/Prime Power Outage
- Dirty Air Filter Alarm
- DC Free Cooling Damper Fails to Open Alarm
- DC Free Cooling Damper Fails to Close Alarm
- Communication Failed Alarm
- Supply Air Temperature Sensor Failed Alarm
- Outdoor Temperature Sensor Failed Alarm
- Outdoor Humidity Sensor Failed Alarm
- Return Air Temperature Sensor Failed Alarm

**NOTE:** See D-Series and LC2000 Installation Manual for Network, LC Controller and Shelter Alarms.

### Clearances Required for Service Access and Adequate Condenser Inlet Airflow

MODELS	LEFT SIDE	RIGHT SIDE
D35A	15"	20"

**NOTE:** For side-by-side installation of two (2) D\*\*A models, there must be 20" between units. This can be reduced to 15" by using a D\*\*L model (left side compressor and controls) for the left unit and D\*\*A (right side compressor and controls) for right unit.

### Minimum Clearances Required to Combustible Materials

MODELS ①	SUPPLY AIR DUCT FIRST THREE FEET	CABINET
D35A	1/4"	0"

① Refer to the Installation Manual for more detailed information.

### Dimensions of D25A & D35A Basic Unit for Architectural & Installation Requirements (Nominal)

MODEL	WIDTH (W)	DEPTH (D)	HEIGHT (H)	SUPPLY		RETURN																
				A	B	C	B	E	F	G	I	J	K	L	M	N	O	P	Q	R	S	T
D35A	38.200	17.125	74.563	7.88	27.88	13.88	27.88	40.00	17.20	29.75	17.93	30.75	32.75	33.25	31.00	2.75	39.13	26.75	9.14	4.19	12.00	9.00

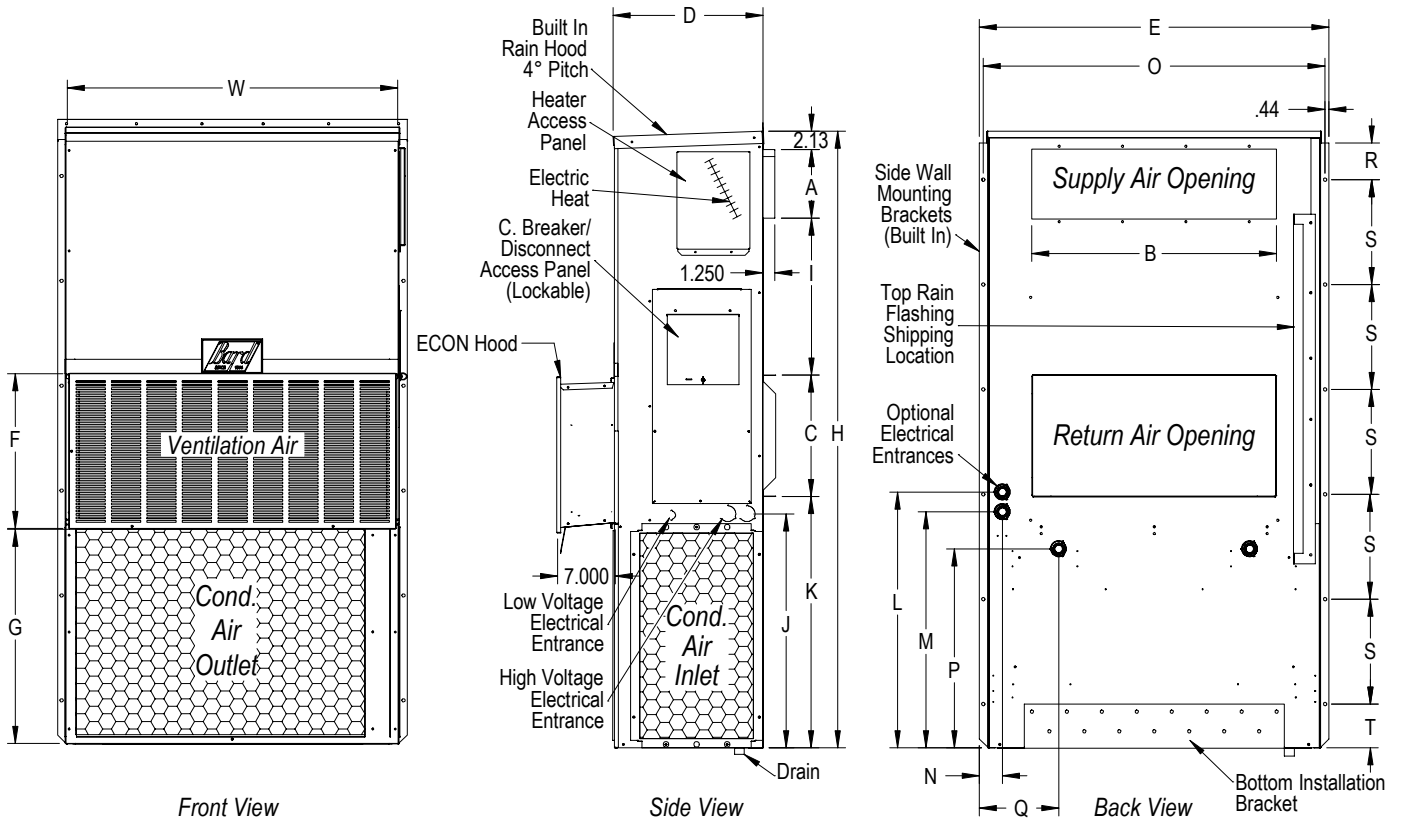

MIS-3849

### Clearances Required for Service Access and Adequate Condenser Inlet Airflow

MODELS	LEFT SIDE	RIGHT SIDE
D35L	15"	20"

**NOTE:** For side-by-side installation of two (2) D\*\*L models, there must be 20" between units. This can be reduced to 15" by using a D\*\*L model (left side compressor and controls) for the left unit and D\*\*A (right side compressor and controls) for right unit.

### Minimum Clearances Required to Combustible Materials

MODELS ①	SUPPLY AIR DUCT FIRST THREE FEET	CABINET
D35L	1/4"	0"

① Refer to the Installation Manual for more detailed information.

### Dimensions of D25L & D35L Basic Unit for Architectural & Installation Requirements (Nominal)

MODEL	WIDTH (W)	DEPTH (D)	HEIGHT (H)	SUPPLY		RETURN																
				A	B	C	B	E	F	G	I	J	K	L	M	N	O	P	Q	R	S	T
D35L	38.200	17.125	74.563	7.88	27.88	13.88	27.88	40.00	17.20	29.75	17.93	30.75	32.75	33.25	31.00	2.75	39.13	26.75	9.14	4.19	12.00	9.00

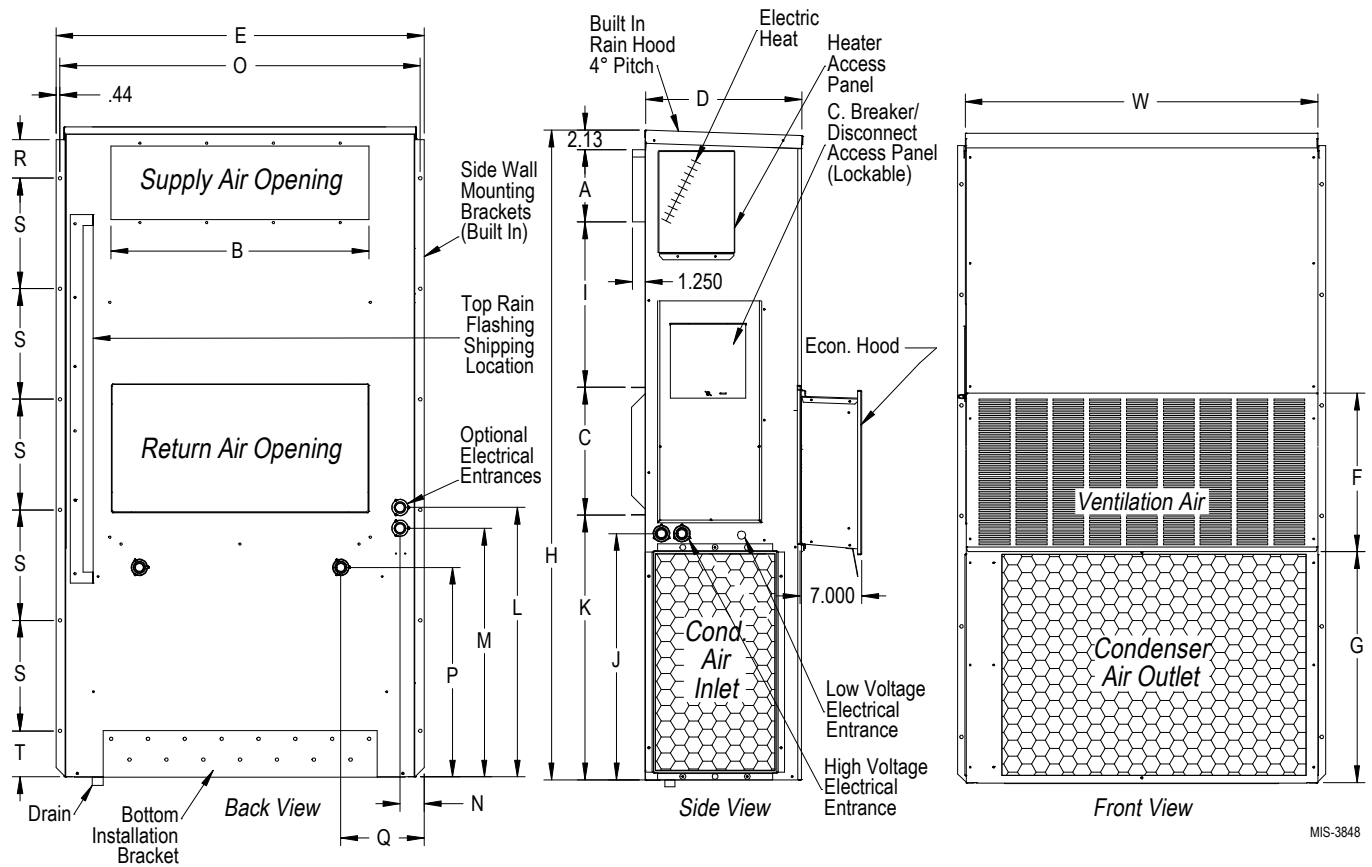

MS-3848

**This page intentionally left blank.**

## Air Conditioning Wall-Mount Model Nomenclature 1-Stage Compressor Models

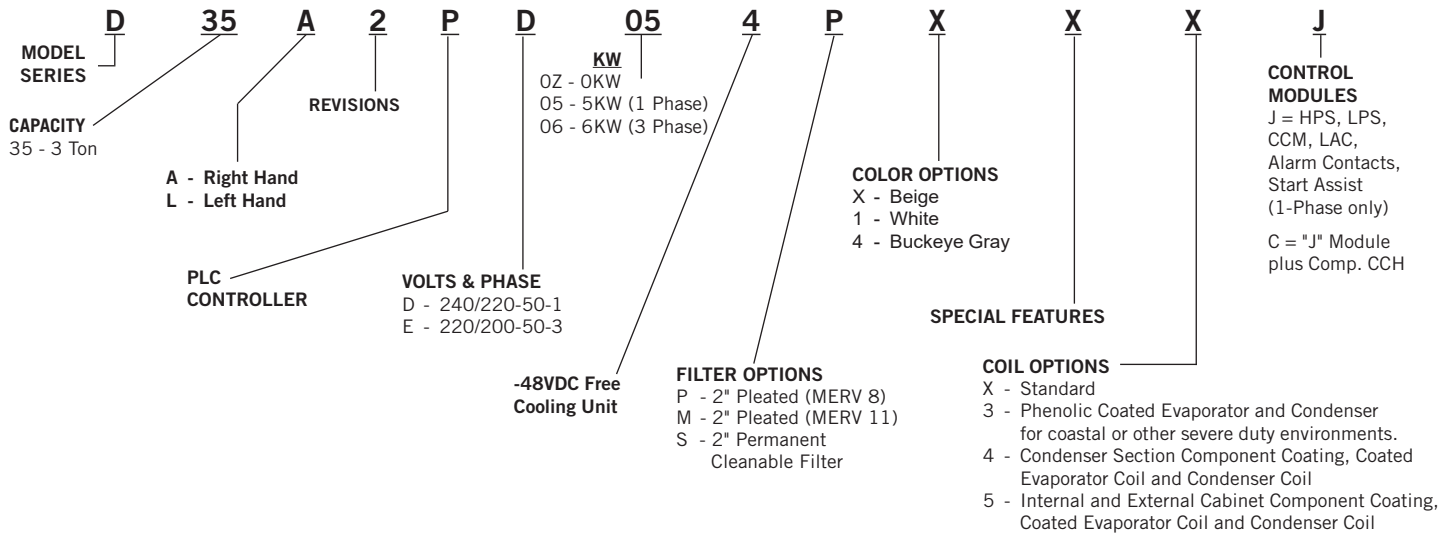

## DUAL-TEC™ Standard Controls

**High Pressure Switch:** **Required Safety Device** that also provides protection to the compressor system when system refrigerant pressure is above an acceptable level. Auto Reset, 650 psig. Output to compressor control module.

**Low Pressure Switch:** Provides protection to the compressor when refrigerant pressure falls below an acceptable level. Auto Reset, cut out at 40 psig. Output to compressor control module.

**Low Ambient Control:** Modulating control that removes power from the condenser fan to allow for unit compressor cooling operation at outdoor ambient temperatures below 65°F. Factory set for system performance. Screw-on connection for easy servicing. Output to condenser fan motor.

**Compressor Control Module:** Compressor protection device that has a 30-second to 5-minute timer. This module features a delay-on-make for initial startup for a minimum of 2 minutes plus 10% of the timer setting. There is no delay during routine operation. Allows one automatic retry after high pressure switch activation, then goes into hard lockout mode. Output to PLC logic board.

**Start Assist (Single Phase Models Only):** PTCR motor starting device increases compressor motor torque 2-3 times.

**Supply Air Sensor:** 10K Thermistor measures supply air temperature, output to PLC logic board.

**Return Air Sensor:** 10K Thermistor measures return air temperature, output to PLC logic board.

**Evaporator Coil Sensor:** 10K Thermistor prevents coil freezing due to low return air temperature. Output to PLC logic board.

**Outdoor Temperature & Enthalpy Sensor:** 10K Temperature sensor and 4-20mA humidity transmitter, output to PLC logic board (PLC defaults to temperature only).

**Phase Monitor (3-Phase Models Only):** Prevents 3-phase compressor operation to protect the compressor if the device senses incorrect phasing. LED indicator light.

**Filter Switch:** Adjustable switch to indicate the unit air filter needs to be replaced. Output to PLC logic board.

## DUAL-TEC™ Optional Controls

**Compressor Crankcase Heater:** 2-wire heater that prevents refrigerant migration and mixing with crankcase oil when the unit is off, prevents condensation of refrigerant in the crankcase of the compressor, and keeps refrigerant at a temperature higher than the coldest part of the system. [Recommended for Canada and cold climate compressor operation.](#)



Bard Manufacturing Company, Inc.  
Bryan, Ohio 43506  
www.bardhvac.com

**Due to our continuous product improvement policy, all specifications subject to change without notice.**

Before purchasing this appliance, read important energy cost and efficiency information available from your retailer.

**Form No.  
S3544  
April 2018**

Supersedes: 118