SERVICE INSTRUCTIONS WITH REPLACEMENT PARTS LIST

LV1000-200 CONTROLLER



NOTE: LV1000 controller is required for operation when FUSION-TEC® HRBP wall-mount units are used.**



Climate Control Solutions

Bard Manufacturing Company, Inc.
Bryan, Ohio 43506
www.bardhvac.com

Manual : 2100-673F
Supersedes: 2100-673E
Date: 2-20-19

CONTENTS

Using the LV1000 Interface.....	5	Passive Dehumidification	21
LV1000 Controller Interface	5	Active Dehumidification	21
System Interface Structure/ Menu Password Levels	5	Fan Control	22
Main Menu	6	Hour Counting	22
Status Screen	6	Troubleshooting	23
Quick Menu	6	8403-079 Remote Indoor Temperature/Humidity Sensor	23
Setpoints	6	LV1000 Modbus TCP Register List	25
Information	7	Input Registers (Read Only)	25
System Information	7	Holding Registers (Read/Write)	26
System Demand.....	7	Discrete Inputs (Read Only)	27
Shelter Last 24 Hours	7	LV1000 Replacement Parts	30
Shelter Info.....	7	FIGURES AND TABLES	
Software Info.....	7	Figure 1 LV1000 Controller Display and Interface...5	
Unit Information.....	8	Figure 2 Quick Menu Icon	6
Unit Main Status Screen Mirror.....	8	Figure 3 Enabling Comfort Mode.....	7
Unit A/C Circuit Information.....	8	Figure 4 System Demand	7
Unit Model/Serial Number/ Software Version	8	Figure 5 Shelter Last 24 Hours.....	7
Unit Last 24 Hours Operation	9	Figure 6 Shelter Info.....	7
Alarm Log	9	Figure 7 Software Info	8
Changing to Celsius	9	Figure 8 Unit Main Status Screen Mirror.....	8
Calibrating Sensors.....	9	Figure 9 Unit A/C Circuit Information	8
Reset to Factory Defaults	9	Figure 10 Unit Model/Serial Number and Software Version	8
Clear Alarm Logs	9	Figure 11 Unit Last 24 Hours Operation	9
IP Configuration	10	Figure 12 Restoring Factory Default Settings.....	9
Modbus TCP Configuration	10	Figure 13 Clearing LV1000 Alarm Logs	9
Alarms	11	Figure 14 IPv4 Configuration	10
Alarm Adjustment	11	Figure 15 Modbus TCP Setup.....	10
Acknowledging/Clearing Alarms.....	11	Figure 16 Clearing All Alarms	11
Sensor Failure Alarms	11	Figure 17 Adjusting Temperature Alarm Setpoints ..	11
Temperature Alarms	11	Figure 18 Adjusting Humidity Alarm Setpoints.....	12
Low Temperature Alarm	11	Figure 19 Changing Input Values	13
High Temperature Warning.....	11	Figure 20 Adjusting Units Running When Generator is Active	14
High Temperature Alarm	12	Figure 21 Adjusting Economizers Running When Generator is Active	15
Humidity Alarms	12	Figure 22 Changing Output Values	15
Low Humidity Alarm.....	12	Figure 23 Changing HVAC Fail Outputs	16
High Humidity Alarm.....	12	Figure 24 Changing HVAC Maintenance Outputs	16
Smoke Alarm	13	Figure 25 Adjusting Setpoints	18
Hydrogen Alarm.....	13	Figure 26 Adjusting Unit Rotation Parameters.....	20
Generator Alarm	14	Figure 27 Adjusting Humidifiers Settings.....	21
Utility Power Loss Alarm	15	Figure 28 Adjusting Dehumidification Setpoints.....	22
Inverter Failure Alarm	15	Figure 29 Adjusting Continuous Fan Setting	22
HVAC Fail Alarm.....	15	Figure 30 Last 24 Hours Tracking	22
HVAC Maintenance Alarm.....	16	Figure 31 8403-079 Sensor.....	23
Anti-Theft Alarm.....	16	Figure 32 LV100-200 Wiring Diagram	31
Humidifier Output.....	17	Table 1 LV1000 Passwords (Defaults)	6
Control Operation	18	Table 2 LV1000 System Status Messages.....	6
Temperature Control	18	Table 3 Modbus Unit of Measure (UOM) Values...10	
Control Value Averaging.....	18	Table 4 Temperature and Humidity Sensors	11
Comfort Mode	18	Table 5 Cooling Staging	19
Emergency Vent.....	18	Table 6 Heating Staging.....	21
Emergency Cool.....	18	Table 7 8403-079 Sensor: Voltage/Humidity	24
Cooling.....	18	Table 8 LV1000-200 Terminal Block Index.....	29
Unit Rotation.....	18		
Heating	20		
Humidity Control.....	21		
Humidification	21		
Dehumidification	21		

GENERAL INFORMATION

Air Conditioning System

This Bard air conditioning system is composed of FUSION-TEC HR Series wall-mount air conditioners matched with an LV1000 first on/next on controller. The wall mount units are specifically engineered for telecom/motor control center rooms.

NOTE: *The LV1000 controller and FUSION-TEC HR Series wall-mount units are designed specifically to work together. The LV1000 controller cannot run other Bard models or other brands of systems. They are a complete system, and must be used together.*

Controller

LV1000 controller and accessories included are shown below.

NOTICE

It is important to check the software version during installation to ensure that the latest version has been installed. Current software versions, change log and installation instructions are available on the Bard website at <http://www.bardhvac.com/software-download/>

LV1000-200 Series Controller and Accessories Included with Controller



(1) LV1000 Programmable Logic Controller

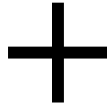

(1) TEC-EYE™ Hand-Held Diagnostic Tool
Bard P/N 8301-059



(1) Remote Temperature/Humidity Sensor¹
Bard P/N 8403-079



(1) 35' 5-Wire 18 Gauge Shielded Cable



(2) Communication EMI Filters
Bard P/N 8301-055

Optional Sensors:



Remote
Temperature/Humidity Sensor¹
Bard P/N 8403-079



Remote
Temperature Only Sensor
Bard P/N 8301-058

¹ One remote temperature/humidity sensor is included with the LV1000 controller. Up to two additional remote temperature/humidity sensors can be purchased and installed. Temperature-only sensors (Bard P/N 8301-058) may be used instead of the additional temperature/humidity sensors, but will also need to be purchased separately. Temperature-only sensors require field-supplied 2-wire shielded cable.

The equipment covered in this manual is to be installed by trained, experienced service and installation technicians.

These instructions should be carefully read before beginning the installation. Note particularly any tags and/or labels attached to the equipment.

While these instructions are intended as a general recommended guide, they do not supersede any national and/or local codes in any way. Authorities having jurisdiction should be consulted before the installation is made. See **Additional Publications** for information on codes and standards.

Shipping Damage

Upon receipt of equipment, the cartons should be checked for external signs of shipping damage. If damage is found, the receiving party must contact the last carrier immediately, preferably in writing, requesting inspection by the carrier’s agent.

Additional Publications

These publications can help when installing the air conditioner. They can usually be found at the local library or purchased directly from the publisher. Be sure to consult the current edition of each standard.

- National Electrical CodeANSI/NFPA 70
- Standard for the Installation of Air Conditioning and Ventilating SystemsANSI/NFPA 90A
- Standard for Warm Air Heating and Air Conditioning SystemsANSI/NFPA 90B
- Load Calculation for Residential Winter and Summer Air Conditioning ACCA Manual J
- Duct Design for Residential Winter and Summer Air Conditioning and Equipment Selection ACCA Manual D

For more information, contact these publishers:

Air Conditioning Contractors of America (ACCA)
1712 New Hampshire Ave. N.W.
Washington, DC 20009
Telephone: (202) 483-9370 Fax: (202) 234-4721

American National Standards Institute (ANSI)
11 West Street, 13th Floor
New York, NY 10036
Telephone: (212) 642-4900 Fax: (212) 302-1286

American Society of Heating, Refrigeration and Air Conditioning Engineers, Inc. (ASHRAE)
1791 Tullie Circle, N.E.
Atlanta, GA 30329-2305
Telephone: (404) 636-8400 Fax: (404) 321-5478

National Fire Protection Association (NFPA)
Batterymarch Park
P. O. Box 9101
Quincy, MA 02269-9901
Telephone: (800) 344-3555 Fax: (617) 984-7057

ANSI Z535.5 Definitions:

DANGER: Indicate[s] a hazardous situation which, if not avoided, will result in death or serious injury. The signal word “DANGER” is to be limited to the most extreme situations. DANGER [signs] should not be used for property damage hazards unless personal injury risk appropriate to these levels is also involved.

WARNING: Indicate[s] a hazardous situation which, if not avoided, could result in death or serious injury. WARNING [signs] should not be used for property damage hazards unless personal injury risk appropriate to this level is also involved.

CAUTION: Indicate[s] a hazardous situation which, if not avoided, could result in minor or moderate injury. CAUTION [signs] without a safety alert symbol may be used to alert against unsafe practices that can result in property damage only.

NOTICE: [this header is] preferred to address practices not related to personal injury. The safety alert symbol shall not be used with this signal word. As an alternative to “NOTICE” the word “CAUTION” without the safety alert symbol may be used to indicate a message not related to personal injury.



USING THE LV1000 INTERFACE

FIGURE 1
LV1000 Controller Display and Interface (Status Screen Shown)



ALARM KEY

Allows viewing of active alarms
Silences audible alarms
Resets active alarms

MENU KEY

Allows entry to Main Menu

ESCAPE KEY

Returns to previous menu level
Cancels a changed entry

UP KEY

Steps to next screen in the display menu
Changes (increases) the value of a modifiable field

ENTER KEY

Accepts current value of a modifiable field
Advances cursor

DOWN KEY

Steps back to previous screen in the display menu
Changes (decreases) the value of a modifiable field

LV1000 Controller Interface

The microprocessor control used in the FUSION-TEC HR Series wall-mount air conditioners allows for complete control and monitoring through the use of the LV1000 controller. These controllers utilize the latest in state-of-the-art technology including a large, easy-to-read backlit LCD graphic display.

The menu driven interface provides users the ability to scroll through two menu levels: Quick Menu and Main Menu. The menus permit the user to easily view, control and configure the unit.

The controller is completely programmed at the factory; therefore, most applications will require no field set-up. However, the default setpoints and their ranges are easily viewed and adjusted from the controller display. The program and operating parameters are permanently stored on FLASH-MEMORY in case of power failure. The controller is designed to manage temperature levels to a user-defined setpoint via control output signals to the wall-mount air conditioning system.

NOTE: Screenshots shown in this manual reflect default settings (when applicable).

System Interface Structure/Menu Password Levels

Quick Menu

Setpoints (Comfort Mode)

Information

System Information

Unit 1 Information

Unit 2 Information (when configured)

Unit 3 Information (when configured)

Unit 4 Information (when configured)

Alarm Log

Main Menu

System Configuration: A1-A10 User (2000)

Adv. System Config: B1-B4 Technician (1313)

I/O Configuration: C1-C18 Technician (1313)

On/Off: User (2000)

Alarm Log: User (2000)

Settings

Date/Time: Technician (1313)

Language: User (2000)

Network Configuration

IPV4: Technician (1313)

Modbus TCP Config: Technician (1313)

Import/Export: User (2000)

Initialization: User (2000)

Change Passwords

Logout

In addition to the menu structure above, there are also Status and Alarm screens.

**TABLE 1
LV1000 Passwords (Defaults)**

User	2000
Technician	1313
Engineer	9254
Use UP or DOWN keys and ENTER key to enter password	

Main Menu

Press the MENU key from any screen to return to the Main Menu. Press the UP or DOWN keys to scroll through the available menus. When the desired menu is highlighted, press the ENTER key to access that menu. Press the ESCAPE key or MENU key to return to the Status screen from the Main Menu.

Status Screen

The Status screen is the default start-up screen and also the return screen after 5 minutes of no activity. The screen can be accessed any time by pressing the ESCAPE key repeatedly. The LV1000 Status screen displays the current date and time, indoor room conditions and system status. See Table 2 for LV1000 system status messages.

The Quick Menu is available on the Status screen. Use UP or DOWN keys while on the Status screen to scroll between the three Quick Menu options (see Figure 2); press ENTER key when the desired icon is displayed.

**FIGURE 2
Quick Menu Icons**



Quick Menu

Setpoints

The Setpoints quick menu allows for a technician in the shelter the ability to set up, enable or disable comfort mode.

To enable comfort mode:

1. From the Status screen, press UP or DOWN key until Quick Menu displays Setpoints icon. Press ENTER key.
2. Press ENTER key to scroll to the Comfort Mode (see Figure 3).
3. Press UP or DOWN key to change value from **OFF** to **ON**.
4. Press ENTER key to save.
5. Press ESCAPE key until Main Menu screen is displayed.

**TABLE 2
LV1000 System Status Messages**

Message	Description
Waiting...	POC is on and has not started the application yet.
Freecooling	System is actively economizing.
Cooling	System is actively mechanical cooling.
Optomized Cool	System is mechanical cooling while actively economizing.
Heating	System is actively heating.
Passive Dehum	System is taking measures to decrease humidity without using extra energy.
Active Dehum	System is taking active measures to decrease humidity.
Power Loss	Unit(s) in system have suffered a power loss.
Inverter Mode	System is operating on inverter power.
Off by Alarm	System has major fault preventing operation.
Off by BMS	System has been turned off from BMS system.
Off by Keypad	System has been turned off by local user.
Unit in Test	Unit(s) in system are currently conducting a self test.
Override Active	There is an active override on the system.
Comfort Mode	System is operating in Comfort Mode.
Emergency Vent	Unit is in Emergency Ventilation. System has active hydrogen alarm.
Emergency Cool	System is in Emergency Cooling. Indoor temperatures have exceeded high temp alarm.
Emergency Off	System is in Emergency Off. System has an active smoke alarm.

FIGURE 3
Enabling Comfort Mode

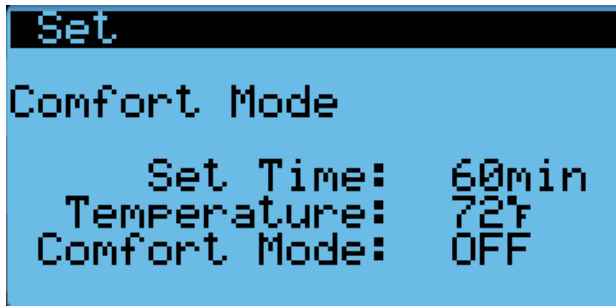

Information

The Information quick menu displays system and unit status information for all devices attached to the system. The info display is broken up into two menu types (system information and unit information). The number of unit information menu items available will depend on the number of units the LV1000 is set up to command.

System Information

The System Information menu displays the following information: system demand, system last 24 hour run times, system last hour averages (indoor temperature, indoor humidity, outdoor temperature and outdoor humidity) and software version information.

System Demand

The System Demand screen displays the current demand that is required from the system to heat or cool the indoor space. Each function of the system has a separate demand that is displayed in the upper portion of the display (see Figure 4). The lower half of the display indicates each output stage that is to be called on for each unit. It will also display **No Device** if a specific unit is not connected. When functions like freecooling or heating are not available, this area will display -- for that specific unit.

FIGURE 4
System Demand

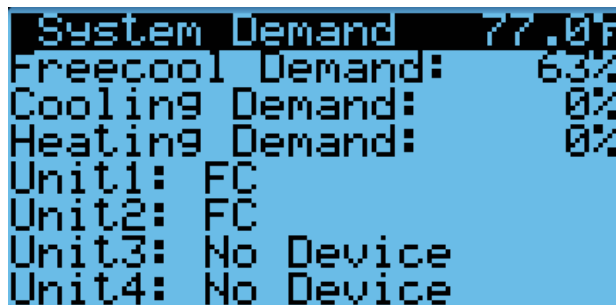

Shelter Last 24 Hours

Last 24 hour operation information tracks the run times (**Run**) and start calls (**ST**) of different NOC output alarms in the last 24 hour period (see Figure 5).

FIGURE 5
Shelter Last 24 Hours

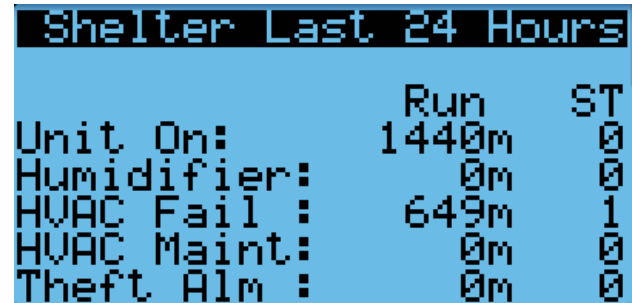

Shelter Info

The Shelter Info screen displays the average temperature/humidity readings of the last hour (see Figure 6).

FIGURE 6
Shelter Info

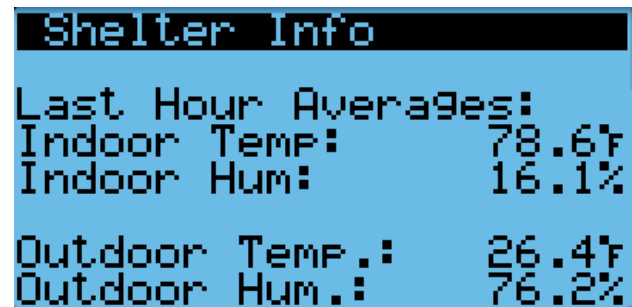

Software Info

The Software Info screen (Figure 7 on page 8) displays the LVS1000 software model code (**SW code**) and software version (**SW ver.**) as well as PLC operating system (**OS ver.**) and boot firmware (**BOOT ver.**). This information can be used to determine whether a software update may be required based on information found in the software change log.

This software change log can be found at <http://www.bardhvac.com/software-download/>.

FIGURE 7
Software Info

```

Software Info
Program Software
  SW code: LVS1000
  SW ver.: 3.0.000
PLC Firmware
  OS ver.: 4.3.002
  Boot ver.: 4.3.002
  
```

FIGURE 8
Unit Main Status Screen Mirror

```

Unit 1 Status
RAT 68.5°F OAT 27.3°F
MAT 68.5°F OAH 82.9%
SAT 53.6°F ODP 23.4°F
Blower: 0% Fan: 0%
Damper: 0%
Mode: LV Online
Output:
  
```

NOTICE

It is important to check the software version during installation to ensure that the latest version has been installed. Current software versions, change log and installation instructions are available on the Bard website at <http://www.bardvac.com/software-download/>

Unit A/C Circuit Information

The A/C Circuit Information screen lists all available A/C sensor measurements and calculations on the unit specified (see Figure 9). The information and measurements provided are liquid line temperature, liquid line pressure, condensing saturated temperature, suction line temperature, suction line pressures, suction saturated temperature, super heat, sub-cooling and electronic expansion valve position.

FIGURE 9
Unit A/C Circuit Information

```

Unit 1 A/C Info
EEV Position: 20%
  T 51°F
  P 139psig→ 49°F
Sub Cooling: 0°F
Super Heat: 0°F
  T 48°F
  P 139psig→ 49°F
  
```

Unit Information

The LV1000 has the ability to provide individual wall unit information which it displays in individual unit information screens. The purpose of these screens is to eliminate the need to remove the panel from a wall unit in order to plug in the TEC-EYE™. Each unit information menu item displays the following information: unit main status screen mirror, unit A/C circuit information, unit model/serial number, unit last 24 hour run times and component lifetimes.

Unit Main Status Screen Mirror

The Unit Main Status screen (Figure 8) mirrors the main status screen of the wall unit. The main status screen also shows the return air temperature (RAT), mixed air temperature (MAT), outdoor air temperature (OAT), outdoor air humidity (OAH) and outdoor dew point (ODP) conditions. Blower speed, condenser fan speed, damper position and unit status are also displayed. In addition to what is displayed on the wall unit's main status screen, this screen also displays the actual wall unit output staging. Refer to the latest version of unit service manual 2100-670 for a list of wall-mount unit status messages.

Unit Model/Serial Number/Software Version

The Unit Model/Serial Number and Software version screen allows the user to verify the model number, serial number and software version from the LV1000 display (see Figure 10).

FIGURE 10
Unit Model/Serial Number and Software Version

```

Unit 1 Info
Serial Number
  385C17342067401
Model Number
  HR58APA0ZEPXXXX
Software Version
  FTS1000.3.0.000
  
```

Unit Last 24 Hours Operation

The Unit Last 24 Hours Operation information tracks the runtimes (**Run**) and start calls (**ST**) of different unit operations in the last 24 hour period (see Figure 11).

FIGURE 11
Unit Last 24 Hours Operation

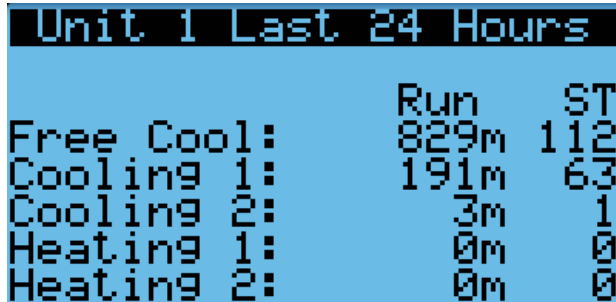

	Run	ST
Free Cool:	829m	112
Cooling 1:	191m	63
Cooling 2:	3m	1
Heating 1:	0m	0
Heating 2:	0m	0

Alarm Log

The alarm log displays the record number, time of alarm event, date of alarm event, description of alarm event and whether the entry is the beginning or end of event. The data log will have as many screens as events occurred, up to 64 entries.

Changing to Celsius

1. Press MENU key to go to the Main Menu screen.
2. Use UP or DOWN keys and ENTER key to enter USER password 2000.
3. Press UP or DOWN keys to scroll to **Sys Config**; press ENTER key.
4. Press UP or DOWN keys to scroll to **Unit Setup (A1)**.
5. Press ENTER key to scroll to **UOM**.
6. Press UP and DOWN keys to change value to **SI**.

Calibrating Sensors

1. Press MENU key to go to the Main Menu screen.
2. Use UP or DOWN keys and ENTER key to enter TECHNICIAN password 1313.
3. Press UP or DOWN keys to scroll to **I/O Config**; press ENTER key.
4. Press UP or DOWN keys to scroll to sensor to be adjusted.
5. Press ENTER key to scroll to **Offset**.
6. Press UP or DOWN keys to add or subtract to the sensor offset value.
7. Press ENTER key to save.

Reset to Factory Defaults

To reset the LV controller to factory default settings:

1. Press MENU key to go to the Main Menu screen.
2. Use UP or DOWN keys and ENTER key to enter ENGINEER password 9254.

3. Press UP or DOWN keys to scroll to **Settings**; press ENTER key.
4. Press UP or DOWN keys to scroll to **Initialization**; press ENTER key.
5. Press UP or DOWN keys to scroll to the **Default Installation** screen; press ENTER key.
6. Press ENTER key to scroll to **Reset to Factory Defaults** (see Figure 12).
7. Press UP or DOWN key to value to **YES**; press ENTER key.
8. System will restart with default values.

FIGURE 12
Restoring Factory Default Settings

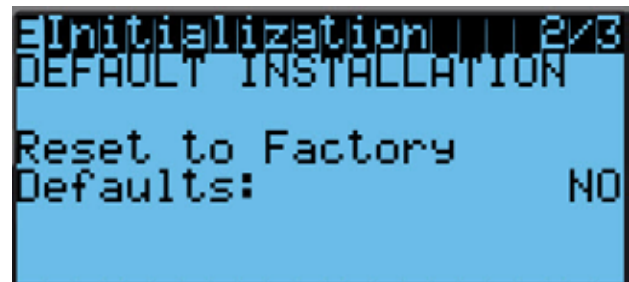

Clear Alarm Logs

To clear the LV controller alarm logs:

1. Press MENU key to go to the Main Menu screen.
2. Use UP or DOWN keys and ENTER key to enter USER password 2000.
3. Press UP or DOWN keys to scroll to **Settings**; press ENTER key.
4. Press UP or DOWN keys to scroll to **Initialization**; press ENTER key.
5. Press ENTER key to scroll to **Clear Alarm Logs?** (see Figure 13).
6. Press UP or DOWN key to value to **YES**; press ENTER key.
7. Press ESCAPE key several times to return to Main Menu screen.

FIGURE 13
Clearing LV1000 Alarm Logs

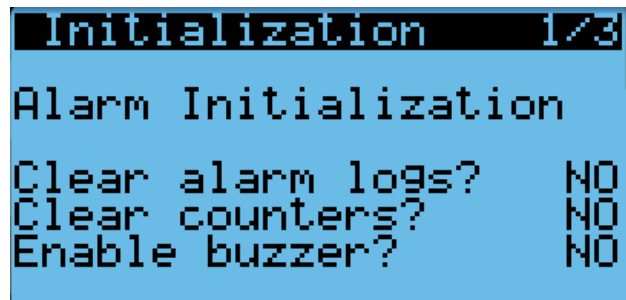

IP Configuration

To set an LV IPv4 address:

1. Press MENU key to go to the Main Menu screen.
2. Use UP or DOWN keys and ENTER key to enter TECHNICIAN password 1313.
3. Press UP or DOWN keys to scroll to **Settings**; press ENTER key.
4. Press UP or DOWN keys to scroll to **Network Config**; press ENTER key.
5. Press UP or DOWN keys to scroll to **IPv4 Config**; press ENTER key.
6. Press ENTER key to scroll to desired value to be changed (see Figure 14).
7. Press UP or DOWN keys to change selected value.
8. Press ENTER key to save and scroll to next value.
9. When finished, press ENTER key until cursor is on the **Update Config** value; change **No** to **Yes** using the UP or DOWN key, then press ENTER key to update network configuration.

NOTE: Enabling/disabling IPv6 or changing from Static IP to hardware-based SLAAC IP will automatically reboot the PLC when **Update Config** value is changed.

FIGURE 14
IPv4 Configuration

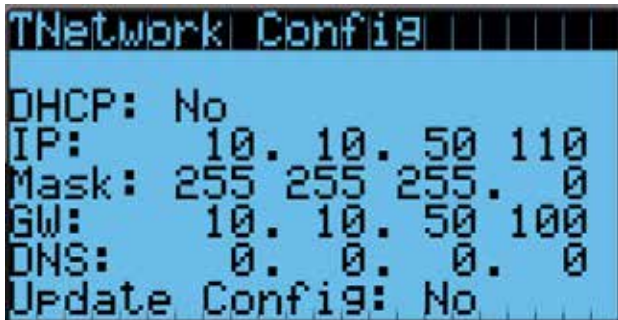

Modbus TCP Configuration

LV1000 version 1.1.0 and higher include Modbus RTU over TCP included on the Ethernet connection. This is a Modbus Slave device and requires a Modbus Master device to properly communicate. Modbus Register list can be found on page 25 of this manual.

To make changes to the Modbus setup:

1. Press MENU key to go to the Main Menu screen.
2. Use UP or DOWN keys and ENTER key to enter TECHNICIAN password 1313.
3. Press UP or DOWN keys to scroll to **Settings**; press ENTER key.
4. Press UP or DOWN keys to scroll to **ModbusTCP Config**; press ENTER key.

5. Press ENTER key to scroll to **Address** (see Figure 15).
6. Press UP or DOWN keys change the Modbus address.
7. Press ENTER key to scroll to **Port**.
8. Press UP or DOWN keys change the Port number if needed. (Default is port 502.)
9. Press ENTER key to scroll to **UOM**.
10. Press UP or DOWN keys change the Unit of Measure for Modbus values (see Table 3).

FIGURE 15
Modbus TCP Setup



TABLE 3
Modbus Unit of Measure (UOM) Values

UOM Type	Temperature UOM	Pressure UOM
SI	°C	KPA
USA (Default)	°F	PSI
UK	°C	BAR
CAN	°C	PSI
LON	°C	KPA

NOTE: Screenshots shown in this manual reflect default settings (when applicable).

Alarm Adjustment

Acknowledging/Clearing Alarms

When there are active alarm conditions on the system, a red LED indicator will backlight the ALARM function key. As an option, an alarm condition may also be enunciated by an audible alarm signal. Active alarms on the system can be viewed by pressing the ALARM key. This calls up the alarm display screen(s) that provide a text message detailing the active alarm condition(s).

After an alarm condition is corrected, the alarm can be cleared by pressing the ALARM key for 3 seconds if that specific alarm is not self-clearing. To reset all alarms on the system, from the alarm display screen, press UP or DOWN key until the screen appears that states **Press ALARM for 3s to reset all alarms** and press the ALARM key for 3 seconds (see Figure 16). If alarms do not clear, the alarm condition is still present. If the alarms clear, the screen should display **NO ALARMS**.

FIGURE 16
Clearing All Alarms



Sensor Failure Alarms

The controller is capable of determining if a sensor has failed. If the temperature or humidity measurement is outside the ranges shown in Table 4, the controller will consider the sensor as failed.

The sensor failure alarms are self clearing.

TABLE 4
Temperature and Humidity Sensors

Sensor	Range
Indoor Temperature 1	-41°F to 303°F
Indoor Temperature 2	-41°F to 303°F
Indoor Temperature 3	-41°F to 303°F
Indoor Humidity 1	10-90%
Indoor Humidity 2	10-90%
Indoor Humidity 3	10-90%

Temperature Alarms (Low Temp, High Temp Warn, High Temp Alarm)

Low Temperature Alarm

The LV will indicate an indoor low temperature alarm when any of the connected sensors that are enabled read a value below the low temperature limit of 40°F (factory default). By default, this alarm uses the average of sensors if more than one space sensor is used.

The low temperature alarm is self clearing.

To adjust the low temperature alarm setpoint:

1. Press MENU key to go to the Main Menu screen.
2. Use UP or DOWN keys and ENTER key to enter USER password 2000.
3. Press UP or DOWN keys to scroll to **Sys Config**; press ENTER key.
4. Press UP or DOWN keys to scroll to **Alarm Setpoints (A8)**.
5. Press ENTER key to scroll to **Low Temp** (see Figure 17).
6. Press UP or DOWN keys to adjust setpoint.

FIGURE 17
Adjusting Temperature Alarm Setpoints

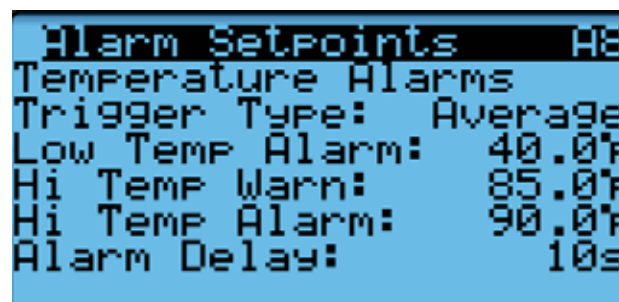

High Temperature Warning

The LV will indicate a high temperature warning alarm when any of the connected sensors that are enabled read a value above the high temperature limit of 85°F (factory default). By default, this alarm uses the average of sensors if more than one space sensor is enabled.

The high temperature warning alarm is self clearing.

To adjust the high temperature warning setpoint:

1. Press MENU key to go to the Main Menu screen.
2. Use UP or DOWN keys and ENTER key to enter USER password 2000.
3. Press UP or DOWN keys to scroll to **Sys Config**; press ENTER key.

4. Press UP or DOWN keys to scroll to **Alarm Setpoints (A7)**.
5. Press ENTER key to scroll to **High Temp Warn** (see Figure 17).
6. Press UP or DOWN keys to adjust setpoint.

High Temperature Alarm

The LV will indicate a high temperature alarm when any of the connected sensors that are enabled read a value above the high temperature limit of 90°F (factory default). By default, this alarm uses the average of sensors if more than one space sensor is enabled. In addition to the alarm being generated, this event will put the system into Emergency Cool mode. See **Emergency Cool** on page 18 for more information.

To adjust the high temperature alarm setpoint:

1. Press MENU key to go to the Main Menu screen.
2. Use UP or DOWN keys and ENTER key to enter USER password 2000.
3. Press UP or DOWN keys to scroll to **Sys Config**; press ENTER key.
4. Press UP or DOWN keys to scroll to **Alarm Setpoints (A7)**.
5. Press ENTER key to scroll to **High Temp Alarm** (see Figure 17).
6. Press UP or DOWN keys to adjust setpoint.

The trigger type for the low temperature, high temperature warning and high temperature alarms can be changed to reference either the displayed average or the lowest value (for low temperature alarm) and the highest value (for high temperature alarms). This only applies to multiple sensor installations. If only one sensor is used, this does not affect operation.

The default setting is **Average**.

To adjust the temperature alarms trigger type:

1. Press MENU key to go to the Main Menu screen.
2. Use UP or DOWN keys and ENTER key to enter USER password 2000.
3. Press UP or DOWN keys to scroll to **Sys Config**; press ENTER key.
4. Press UP or DOWN keys to scroll to **Alarm Setpoints (A7)**.
5. Press ENTER key to scroll to **Trigger Type** (see Figure 17).
6. Press UP or DOWN keys to change from **Average** to **Hi/Low**.

A delay of 10 seconds (factory default) is applied to each alarm. This can be adjusted by:

1. Press MENU key to go to the Main Menu screen.
2. Use UP or DOWN keys and ENTER key to enter USER password 2000.

3. Press UP or DOWN keys to scroll to **Sys Config**; press ENTER key.
4. Press UP or DOWN keys to scroll to **Alarm Setpoints (A7)**.
5. Press ENTER key to scroll to **Alarm Delay** (see Figure 17).
6. Press UP or DOWN keys to adjust the delay.

Humidity Alarms (Low Hum, High Hum)

Low Humidity Alarm

The LV will indicate an indoor low humidity alarm when any of the connected sensors that are enabled read a value below the low humidity limit of 10% RH (factory default). By default, this alarm uses the average of sensors if more than one space sensor is enabled.

The low humidity alarm is self clearing.

To adjust the low humidity alarm setpoint:

1. Press MENU key to go to the Main Menu screen.
2. Use UP or DOWN keys and ENTER key to enter USER password 2000.
3. Press UP or DOWN keys to scroll to **Sys Config**; press ENTER key.
4. Press UP or DOWN keys to scroll to **Alarm Setpoints (A8)**.
5. Press ENTER key to scroll to **Low Hum** (see Figure 18).
6. Press UP or DOWN keys to adjust setpoint.

FIGURE 18
Adjusting Humidity Alarm Setpoints

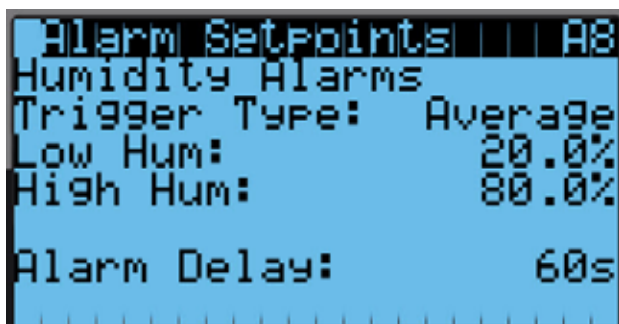

High Humidity Alarm

The LV will indicate a high humidity alarm when any of the connected sensors that are enabled read a value above the high humidity limit of 80% RH (factory default). By default, this alarm uses the average of sensors if more than one space sensor is enabled.

The high humidity alarm is self clearing.

To adjust the high humidity alarm setpoint:

1. Press MENU key to go to the Main Menu screen.

2. Use UP or DOWN keys and ENTER key to enter USER password 2000.
3. Press UP or DOWN keys to scroll to **Sys Config**; press ENTER key.
4. Press UP or DOWN keys to scroll to **Alarm Setpoints (A8)**.
5. Press ENTER key to scroll to **High Hum** (see Figure 18).
6. Press UP or DOWN keys to adjust setpoint.

The trigger type for the low humidity and high humidity alarms can be changed to reference either the displayed average or the lowest value (for low humidity alarm) and the highest value (for high humidity alarm). This only applies to multiple sensor installations. If only one sensor is used, this does not affect operation.

The default setting is **Average**.

To adjust the temperature alarms trigger type:

1. Press MENU key to go to the Main Menu screen.
2. Use UP or DOWN keys and ENTER key to enter USER password 2000.
3. Press UP or DOWN keys to scroll to **Sys Config**; press ENTER key.
4. Press UP or DOWN keys to scroll to **Alarm Setpoints (A8)**.
5. Press ENTER key to scroll to **Trigger Type** (see Figure 18).
6. Press UP or DOWN keys to change from **Average** to **Hi/Low**.

A delay is available to be applied to each humidity alarm (default is 60 seconds). This can be adjusted by:

1. Press MENU key to go to the Main Menu screen.
2. Use UP or DOWN keys and ENTER key to enter USER password 2000.
3. Press UP or DOWN keys to scroll to **Sys Config**; press ENTER key.
4. Press UP or DOWN keys to scroll to **Alarm Setpoints (A8)**.
5. Press ENTER key to scroll to **Alarm Delay** (see Figure 18).
6. Press UP or DOWN keys to adjust the delay.

Smoke Alarm

The LV will indicate a smoke alarm when the smoke detector input is activated in the shelter. This input is enabled by default. To utilize this input, connect the detector alarm relay to the smoke detector input and smoke detector common. The alarm will be communicated to all of the wall-mount units. The LV1000 will disable all operations and all connected wall-mount units will be disabled so that no operations occur while a smoke alarm is present. See smoke alarm

installation instructions for specific wiring information. This alarm requires a user to manually reset it in order for the system to resume operation.

NOTE: The variable provided in the *Direction* column of the *Digital In Config (C1)* screen (as shown in Figure 19) displays either **NO** (Normally Open) or **NC** (Normally Closed). This column lists the type of signaling contact connected to the LV1000. If connected to an **NO** contact on the smoke detector, the input circuit will be closed if there is a smoke event. Therefore, in this case the LV1000 must be set to look for **NO**.

To change the smoke inputs:

1. Press MENU key to go to the Main Menu screen.
2. Use UP or DOWN keys and ENTER key to enter TECHNICIAN password 1313.
3. Press UP or DOWN keys to scroll to **IO Config**; press ENTER key.
4. Press UP or DOWN keys to scroll to **Digital In Config (C1)**.
5. Press ENTER key to scroll to the variable in the table that intersects **Smoke** and **Dir** (see Figure 19).
6. Press UP or DOWN key to change direction.
7. Press ENTER key to save the value and move cursor to variable in the table that intersects **Smoke** and **En**.
8. Press UP or DOWN keys to change the value from **ON** to **OFF**.

FIGURE 19
Changing Input Values

DI#	Dir	En	Val
1	Smoke	NO	ON
2	Hydro	NC	ON
3	Gen	NC	ON
4	Theft	NC	OFF
5	Invert	NC	OFF

Hydrogen Alarm

The LV will indicate a hydrogen alarm when the hydrogen detector indicates high levels of hydrogen inside the shelter. This input is enabled by default but comes with a factory-installed jumper. To utilize this input, remove the jumper and connect the sensor in place of the jumper. In addition to the alarm being generated, this event will put the system into emergency vent mode. See **Emergency Vent** on page 18 for more information. This alarm will automatically

clear when the hydrogen detector no longer indicates hydrogen is present.

NOTE: The variable provided in the Direction column of the Digital In Config (C1) screen (as shown in Figure 19) displays either NO (Normally Open) or NC (Normally Closed). This column lists the type of signaling contact connected the LV1000. If connected to an NC contact on the hydrogen detector, the input circuit will be open if there is a hydrogen event. Therefore, in this case the LV1000 must be set to look for NC.

To change the hydrogen inputs:

1. Press MENU key to go to the Main Menu screen.
2. Use UP or DOWN keys and ENTER key to enter TECHNICIAN password 1313.
3. Press UP or DOWN keys to scroll to **IO Config**; press ENTER key.
4. Press UP or DOWN keys to scroll to **Digital In Config (C1)**.
5. Press ENTER key to scroll to the variable in the table that intersects **Hydro** and **Dir** (see Figure 19).
6. Press UP or DOWN key to change direction.
7. Press ENTER key to save the value and move cursor to variable in the table that intersects **Hydro** and **En**.
8. Press UP or DOWN keys to change the value from **ON** to **OFF**.

Generator Alarm

The LV will indicate a generator run alarm when the generator run input indicates that the generator is running. This input is enabled by default but comes with a factory-installed jumper. To utilize this input, remove the jumper and connect the generator in place of the jumper.

NOTE: The variable provided in the Direction column of the Digital In Config (C1) screen (as shown in Figure 19) displays either NO (Normally Open) or NC (Normally Closed). This column lists the type of signaling contact connected the LV1000. If connected to an NC contact on the generator, the input circuit will be open when the generator is running. Therefore, in this case the LV1000 must be set to look for NC.

To change the generator inputs:

1. Press MENU key to go to the Main Menu screen.
2. Use UP or DOWN keys and ENTER key to enter TECHNICIAN password 1313.
3. Press UP or DOWN keys to scroll to **IO Config**; press ENTER key.
4. Press UP or DOWN keys to scroll to **Digital In Config (C1)**.

5. Press ENTER key to scroll to the variable in the table that intersects **Gen** and **Dir** (see Figure 19).
6. Press UP or DOWN key to change direction.
7. Press ENTER key to save the value and move cursor to variable in the table that intersects **Gen** and **En**.
8. Press UP or DOWN keys to change the value from **ON** to **OFF**.

While the generator is running, the system will only allow selected units to run. This selection is customizable by the end user. This limitation is in place to match the unit power requirements to the shelter generator capacity.

The default for this setting is 1 unit is permitted to run if 1, 2, or 3 is selected for the number of units installed on the shelter. If the shelter is configured for 4 units, the default will be 2 units. If a different strategy is required, the end user can select which units by address are allowed to run when the generator run input is active.

To change which units run when the generator run input is active:

1. Press MENU key to go to the Main Menu screen.
2. Use UP or DOWN keys and ENTER key to enter TECHNICIAN password 1313.
3. Press UP or DOWN keys to scroll to **Adv System Config**; press ENTER key.
4. Press UP or DOWN keys to scroll to **Unit Inhibit (B3)**.
5. Press ENTER key to scroll to **Unit 1** (see Figure 20).
6. Press UP or DOWN key to change **Enabled on Gen** to **Disabled on Gen**.
7. Press ENTER key to save the value and move cursor to **Unit 2**.
8. Press UP or DOWN keys and ENTER key to change units to **Disabled on Gen** as needed.

FIGURE 20
Adjusting Units Running When Generator is Active

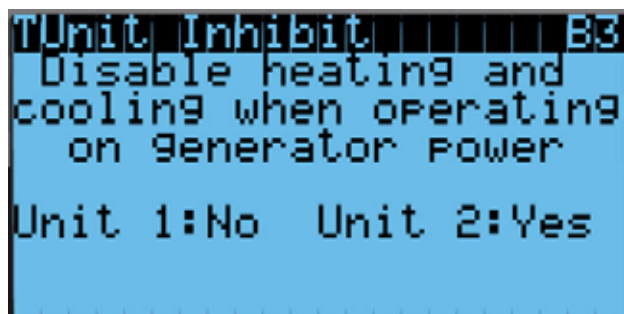

The system will also disable economizer operation of all wall-mount units when the generator is running. This setting can be changed per wall-mount unit by the end user to allow the economizer to operate if the exhaust of the generator is far enough away from the wall-mount unit's fresh air intake.

To change which units can use the economizer when the generator run input is active:

1. Press MENU key to go to the Main Menu screen.
2. Use UP or DOWN keys and ENTER key to enter TECHNICIAN password 1313.
3. Press UP or DOWN keys to scroll to **Adv System Config**; press ENTER key.
4. Press UP or DOWN keys to scroll to **Econ Inhibit (B2)**.
5. Press ENTER key to scroll to **Unit 1** (see Figure 21).
6. Press UP or DOWN key to change **Enabled on Gen** to **Disabled on Gen**.
7. Press ENTER key to save the value and move cursor to **Unit 2**.
8. Press UP or DOWN keys and ENTER key to change units to **Disabled on Gen** as needed.

This alarm will clear and operation will return to normal when the generator run input no longer indicates the generator is running.

FIGURE 21
Adjusting Economizers Running
When Generator is Active

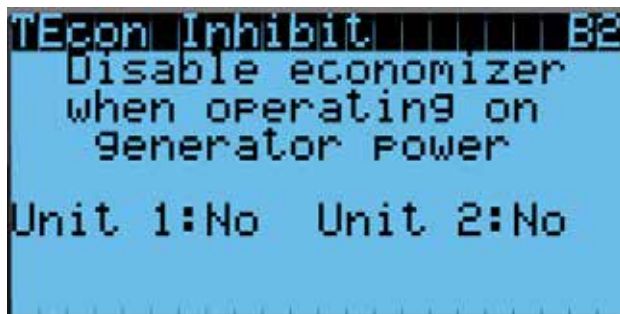

Utility Power Loss Alarm

The LV will indicate a utility power loss alarm if equipped with inverter-ready wall-mount units. When utility power is not present, the wall-mount unit controller will detect a power loss and communicate the event to the LV. The LV will then indicate a utility power loss alarm. When the power loss alarm is no longer present, the alarm will automatically clear.

Inverter Failure Alarm

The LV has the ability to monitor the VIC Series inverter (sold separately) for a failure. Once wired from the inverter

fault relay in the VIC inverter to terminals 16 and 17 in the LV1000-200, the LV will alarm on inverter failure.

NOTE: The variable provided in the *Direction* column of the *Digital In Config (C1)* screen (as shown in Figure 19) displays either *NO (Normally Open)* or *NC (Normally Closed)*. This column lists the type of signaling contact connected to the LV1000. If connected to an *NC contact* on the inverter, the input circuit will be open when the inverter reports a fault. Therefore, in this case the LV1000 must be set to look for *NC*.

HVAC Fail Alarm

The LV monitors all connected wall-mount unit alarms. If any of the units communicate specific alarms, the LV will actuate an HVAC fail alarm relay output. The following wall-mount unit events have the possibility of actuating an HVAC failure: High pressure (always), low pressure (always), blower failure (always), high temperature warning (user selectable), high temperature alarm (user selectable) and low temperature alarm (user selectable). Each event will be displayed individually on the LV. However, any of these alarms (when enabled) will actuate the alarm relay for HVAC failure. This output is connected to the NOC for remote notification. When all of these events are no longer present, the alarm relay output will close, signaling there are no HVAC failure alarms.

The LV is will actuate a relay output when this alarm occurs. The output is set up to open when an alarm occurs by default. The direction of this alarm output can be changed if required.

To change the direction of the HVAC fail alarm output:

1. Press MENU key to go to the Main Menu screen.
2. Use UP or DOWN keys and ENTER key to enter TECHNICIAN password 1313.
3. Press UP or DOWN keys to scroll to **IO Config**; press ENTER key.
4. Press UP or DOWN keys to scroll to **Digital Out Config (C2)**.
5. Press ENTER key to scroll to the variable in the table that intersects **HVACfail** and **Dir** (see Figure 22).
6. Press UP or DOWN key to change direction.

FIGURE 22
Changing Output Values

OO#	Dir	Val
1 Hum	NO	OFF
2 HVACfail	NC	ON
3 HVACmaint	NC	ON
4 AntiTheft	NC	ON

To change the alarms that actuate an HVAC fail alarm:

1. Press MENU key to go to the Main Menu screen.
2. Use UP or DOWN keys and ENTER key to enter TECHNICIAN password 1313.
3. Press UP or DOWN keys to scroll to **IO Config**; press ENTER key.
4. Press UP or DOWN keys to scroll to **HVAC Fail Config (C3)**.
5. Press ENTER key to scroll to the failure type enable (see Figure 23).
6. Press UP or DOWN key to change value.
7. Press ENTER key to save.

FIGURE 23
Changing HVAC Fail Outputs

Failure Type	Enable
Hi Temp Warn	Disabled
Hi Temp Alarm	Disabled
Low Temp	Disabled

HVAC Maintenance Alarm

The LV monitors all connected wall-mount unit alarms, and if any of the units communicate specific alarms, the LV will actuate an HVAC maintenance alarm relay output. The following alarms/events have the possibility of actuating an HVAC failure: Dirty filter alarm (always), dirty condenser coil alarm (always), lead +1/lag unit running (user selectable), economizer fail (user selectable), communications failure (user selectable). For all cases except lead +1, each of the alarms will be displayed individually on the LV. However, any of these alarms (when enabled) will actuate the alarm relay for HVAC maintenance, which is connected to the NOC for remote notification. When all of these events are no longer present, the alarm relay output will close signaling there are no HVAC maintenance alarms.

The LV will actuate a relay output when this alarm occurs. The output is set up to open when an alarm occurs by default. The direction of this alarm output can be changed if required.

To change the direction of the maintenance alarm output:

1. Press MENU key to go to the Main Menu screen.
2. Use UP or DOWN keys and ENTER key to enter TECHNICIAN password 1313.

3. Press UP or DOWN keys to scroll to **IO Config**; press ENTER key.
4. Press UP or DOWN keys to scroll to **Digital Out Config (C2)**.
5. Press ENTER key to scroll to the variable in the table that intersects **HVACmaint** and **Dir** (see Figure 22).
6. Press UP or DOWN key to change direction.

To change the alarms that actuate an HVAC maintenance alarm:

1. Press MENU key to go to the Main Menu screen.
2. Use UP or DOWN keys and ENTER key to enter TECHNICIAN password 1313.
3. Press UP or DOWN keys to scroll to **IO Config**; press ENTER key.
4. Press UP or DOWN keys to scroll to **HVAC Maint Config (C4)**.
5. Press ENTER key to scroll to the maintenance type enable (see Figure 24).
6. Press UP or DOWN key to change value.
7. Press ENTER key to save.

FIGURE 24
Changing HVAC Maintenance Outputs

Failure Type	Enable
Lead +1	Disabled
Econ. Fail	Disabled
Comm. Fail	Disabled

Anti-Theft Alarm

The LV will indicate a theft alarm when the Bard Guard anti-theft controller (sold separately) indicates an alarm to the anti-theft input on the LV. This alarm will open an alarm relay output to the NOC for remote notification. When the input no longer indicates a theft, the alarm will automatically clear and the alarm relay will return to its normal state.

NOTE: The variable provided in the Direction column of the Digital In Config (C1) screen (as shown in Figure 19) displays either NO (Normally Open) or NC (Normally Closed). This column lists the type of signaling contact connected the LV1000. If connected to an NC contact on the Bard Guard Anti-Theft Alarm, the input circuit will be open when the Bard Guard reports a theft event. Therefore, in this case the LV1000 must be set to look for NC.

To change the anti-theft alarm inputs:

1. Press MENU key to go to the Main Menu screen.
2. Use UP or DOWN keys and ENTER key to enter TECHNICIAN password 1313.
3. Press UP or DOWN keys to scroll to **IO Config**; press ENTER key.
4. Press UP or DOWN keys to scroll to **Digital In Config (C1)**.
5. Press ENTER key to scroll to the variable in the table that intersects **Theft** and **Dir** (see Figure 19).
6. Press UP or DOWN key to change direction.
7. Press ENTER key to save the value and move cursor to variable in the table that intersects **Theft** and **En**.
8. Press UP or DOWN key to change the value from **OFF** to **ON**.

The LV is will actuate a relay output when this alarm occurs. The output is set up to open when an alarm occurs by default. The direction of this alarm output can be changed if required.

To change the direction of the anti-theft output:

1. Press MENU key to go to the Main Menu screen.
2. Use UP or DOWN keys and ENTER key to enter TECHNICIAN password 1313.
3. Press UP or DOWN keys to scroll to **IO Config**; press ENTER key.
4. Press UP or DOWN keys to scroll to **Digital Out Config (C2)**.
5. Press ENTER key to scroll to the variable in the table that intersects **AntiTheft** and **Dir** (see Figure 22).
6. Press UP or DOWN key to change direction.

Humidifier Output

The LV has the option to control a humidifier (sold separately) through a relay output. The output will close when a humidity call from the LV is active and open when the call is no longer present. The output can be configured to operate in reverse where the contacts will open when a humidity call is present and close when the call is no longer present.

To change the direction of the humidifier output:

1. Press MENU key to go to the Main Menu screen.
2. Use UP or DOWN keys and ENTER key to enter TECHNICIAN password 1313.
3. Press UP or DOWN keys to scroll to **IO Config**; press ENTER key.
4. Press UP or DOWN keys to scroll to **Digital Out Config (C2)**.
5. Press ENTER key to scroll to the variable in the table that intersects **Hum** and **Dir** (see Figure 22).
6. Press UP or DOWN key to change direction.

CONTROL OPERATION

NOTE: Screenshots shown in this manual reflect default settings (when applicable).

Temperature Control

Control Value Averaging

The system requires one temperature and humidity sensor (included with LV) to operate. It allows a **total** of three temperature sensors and three humidity sensors to be connected to the LV for better representation of what is happening in the shelter. When more than one sensor is used, the value is averaged and then used for temperature control operations and humidity control operations.

Comfort Mode

The LV has a feature that allows a temporary override of the temperature control settings. When “comfort mode” is activated, the system will control to 72°F. The system will stay in this mode for 60 minutes and is intended to provide a more comfortable space for a technician during a service call or scheduled maintenance.

Emergency Vent

When the hydrogen input indicates an alarm, the system will enter emergency vent mode. The LV will communicate to each wall-mount unit that emergency vent mode is active. The wall-mount units will then override the damper position to 100% open and, after a short delay to allow the damper to open, turn the blower on. Emergency vent mode will stay active until the hydrogen detector is no longer in an alarm state.

Emergency Cool

When the high temperature alarm is activated, the system will enter emergency cool mode. The LV will communicate to each wall-mount unit that emergency cool mode is active. At that point, the units will override any restrictions to the economizer disable and operate the economizers normally, as long as the outdoor temperature is cooler than the indoor temperature. Emergency cool mode will stay active until the high temperature warning is no longer in an alarm state.

Cooling

When the wall-mount units are connected to the LV, the economizer and compressor are commanded off and on by the LV. This allows the supervisory controller to consider the most effective and efficient order to bring cooling functions on using all of the available equipment installed on the shelter. At the same time, the LV will be able to match the load requirements of the shelter.

To adjust the cooling setpoint:

1. Press MENU key to go to the Main Menu screen.
2. Press UP or DOWN keys and ENTER key to enter USER password 2000.

3. Press UP or DOWN keys to scroll to **Sys Config**; press ENTER key.
4. Press UP or DOWN keys to scroll to **Unit Setup (A1)**; press ENTER key.
5. Press ENTER key to scroll to **Cooling** (see Figure 25).
6. Press UP or DOWN keys to adjust value.
7. Press ENTER key to save.
8. Press the ESCAPE key several times to return to Main Menu screen.

FIGURE 25
Adjusting Setpoints

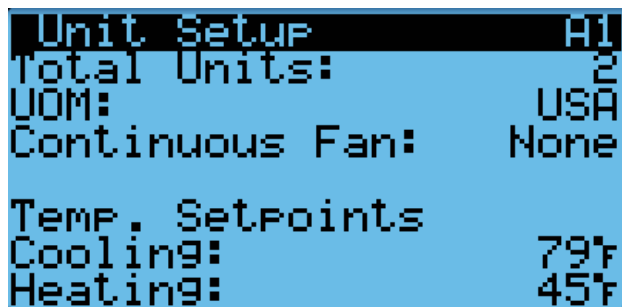

The LV monitors the space temperature and compares the value to the space cooling setpoint. The system will compare how far above or below the space temperature is when compared to the cooling setpoint. The LV will also consider how long the shelter temperature has been above or below the setpoint. Using these two considerations, the controller will generate a cooling demand. The cooling demand is a value between 0 and 100%. 0% represents no cooling demand and 100% representing full cooling demand.

The system will consider all of the available cooling stages and distribute the number of stages across the cooling demand range. As the demand rises, the system will stage on equipment every 2 minutes. As the demand lowers, the system will stage off equipment every 2 minutes.

The system will stage the equipment on in the order shown in Table 5.

Unit Rotation

The system is also capable of rotating the order in which the units are brought on. This is done to distribute the equipment run time to each unit. This prevents one unit from providing all of the cooling for the shelter and shorting the lifespan of the wall-mount unit.

The system is set to switch the unit rotation order every 7 days from the factory. This timeframe is adjustable. In addition to the time-based auto rotation, the system

**TABLE 5
Cooling Staging**

1 Unit		
Order	Freecooling Available	Freecooling Not Available
1	Unit 1 Freecooling	Unit 1 Compressor Stage 1
2	Unit 1 Compressor Stage 1	Unit 1 Compressor Stage 2
3	Unit 1 Compressor Stage 2	--

2 Units		
Order	Freecooling Available	Freecooling Not Available
1	Unit 1 Freecooling	Unit 1 Compressor Stage 1
2	Unit 2 Freecooling	Unit 1 Compressor Stage 2
3	Unit 1 Compressor Stage 1	Unit 2 Compressor Stage 1
4	Unit 1 Compressor Stage 2	Unit 2 Compressor Stage 2
5	Unit 2 Compressor Stage 1	--
6	Unit 2 Compressor Stage 2	

3 Units		
Order	Freecooling Available	Freecooling Not Available
1	Unit 1 Freecooling	Unit 1 Compressor Stage 1
2	Unit 2 Freecooling	Unit 1 Compressor Stage 2
3	Unit 3 Freecooling	Unit 2 Compressor Stage 1
4	Unit 1 Compressor Stage 1	Unit 2 Compressor Stage 2
5	Unit 1 Compressor Stage 2	Unit 3 Compressor Stage 1
6	Unit 2 Compressor Stage 1	Unit 3 Compressor Stage 2
7	Unit 2 Compressor Stage 2	--
8	Unit 3 Compressor Stage 1	
9	Unit 3 Compressor Stage 2	

4 Units		
Order	Freecooling Available	Freecooling Not Available
1	Unit 1 Freecooling	Unit 1 Compressor Stage 1
2	Unit 2 Freecooling	Unit 1 Compressor Stage 2
3	Unit 3 Freecooling	Unit 2 Compressor Stage 1
4	Unit 4 Freecooling	Unit 2 Compressor Stage 2
5	Unit 1 Compressor Stage 1	Unit 3 Compressor Stage 1
6	Unit 1 Compressor Stage 2	Unit 3 Compressor Stage 2
7	Unit 2 Compressor Stage 1	Unit 4 Compressor Stage 1
8	Unit 2 Compressor Stage 2	Unit 4 Compressor Stage 2
9	Unit 3 Compressor Stage 1	--
10	Unit 3 Compressor Stage 2	
11	Unit 4 Compressor Stage 1	
12	Unit 4 Compressor Stage 2	

can be manually rotated on site for troubleshooting purposes.

The system has two different modes for staging unit operation: FIFO (First In/First Out) or FILO (First In/Last Out). With FIFO staging, the first unit on will be the first unit to turn off as demand decreases. In FILO staging, the first unit to turn on will be the last unit to turn off.

To view the lead unit and make adjustments to the unit rotation and staging:

1. Press MENU key to go to the Main Menu screen.
2. Press UP or DOWN keys and ENTER key to enter USER password 2000.
3. Press UP or DOWN keys to scroll to **Sys Config**; press ENTER key.
4. Press UP or DOWN keys to scroll to **Unit Rotation (A2)**; press ENTER key.
5. Press ENTER key to scroll to **Time Based** (see Figure 26).
6. Press UP or DOWN key to change the value from **ON** to **OFF**.
7. Press ENTER key to save the value and scroll to **Num. of Days**.
8. Press UP or DOWN keys to change the value.
9. Press ENTER key to save the value and scroll to **Manual Rotate**.
10. Press UP or DOWN key to change the value from **OFF** to **ON**.
11. Press ENTER key to save the value and scroll to **Staging Order**.
12. Press UP or DOWN keys to change the value from **FIFO** to **FILO**.
13. Press ENTER key to save.
14. Press the ESCAPE key several times to return to Main Menu screen.

FIGURE 26
Adjusting Unit Rotation Parameters

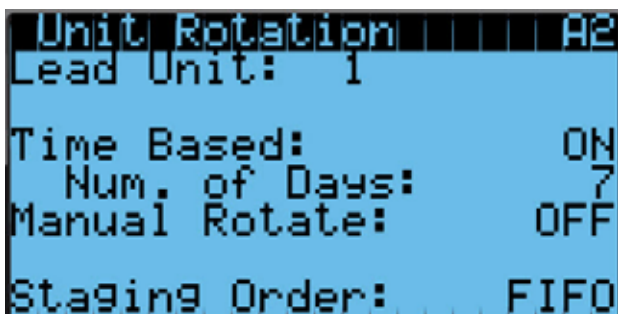

Heating

When the wall-mount units are connected to the LV, the heat strips are commanded off and on by the LV. This allows the supervisory controller to match the required load of the shelter using all of the available equipment installed on the shelter.

To adjust the heating setpoint:

1. Press MENU key to go to the Main Menu screen.
2. Press UP or DOWN keys and ENTER key to enter USER password 2000.
3. Press UP or DOWN keys to scroll to **Sys Config**; press ENTER key.
4. Press UP or DOWN keys to scroll to **Unit Setup (A1)**; press ENTER key.
5. Press ENTER key to scroll to **Heating** (see Figure 25 on page 18).
6. Press UP or DOWN keys to adjust value.
7. Press ENTER key to save.
8. Press the ESCAPE key several times to return to Main Menu screen.

The LV monitors the space temperature and compares the value to the space heating setpoint. The system will compare how far above or below the space temperature is when compared to the heating setpoint. The LV will also consider how long the shelter temperature has been above or below the setpoint. Using these two considerations, the controller will generate a heating demand. The heating demand is a value between 0 and 100%. 0% represents no heating demand and 100% representing full heating demand.

The system will consider all of the available heating stages and distribute the number of stages across the heating demand range. As the demand rises, the system will stage on equipment every 2 minutes. As the demand lowers, the system will stage off equipment every 2 minutes.

The system will stage the equipment on in the order shown in Table 6.

The system is also capable of rotating the order in which the units are brought on. This is done to distribute the equipment run time to each unit. This prevents one unit from providing all of the heating for the shelter and shortening the lifespan of the wall-mount unit.

See **Unit Rotation** on page 18 for information on unit rotation and staging.

TABLE 6
Heating Staging

1 Unit	
Order	Heat Method
1	Unit 1 Heat Strip

2 Units	
Order	Heat Method
1	Unit 1 Heat Strip
2	Unit 2 Heat Strip

3 Units	
Order	Heat Method
1	Unit 1 Heat Strip
2	Unit 2 Heat Strip
3	Unit 3 Heat Strip

4 Units	
Order	Freecooling Available
1	Unit 1 Heat Strip
2	Unit 2 Heat Strip
3	Unit 3 Heat Strip
4	Unit 4 Heat Strip

Humidity Control

The LV will monitor the indoor humidity of the space and compare the value to the indoor humidity lower and upper setpoints.

Humidification

When the humidity is below the lower setpoint of 20% RH and a humidifier output is configured, the shelter will begin to humidify using the relay output to control a third party humidifier.

To change the number of humidifiers, type and setpoint:

1. Press MENU key to go to the Main Menu screen.
2. Press UP or DOWN keys and ENTER key to enter USER password 2000.
3. Press UP or DOWN keys to scroll to **Sys Config**; press ENTER key.
4. Press UP or DOWN keys to scroll to **Unit Setup (A3)**; press ENTER key.
5. Press ENTER key to scroll to **Humidifiers** (see Figure 27).

6. Press UP or DOWN keys to adjust value.
7. Press ENTER key to scroll to **Type**.
8. Press UP or DOWN keys to adjust value.
9. Press ENTER key to scroll to **On Setpoint**.
10. Press UP or DOWN keys to adjust value.
11. Press the ESCAPE key several times to return to Main Menu screen.

FIGURE 27
Adjusting Humidifiers Settings

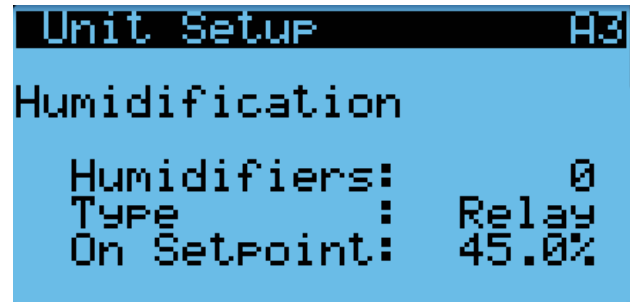

Dehumidification

The system will take several measures to limit the indoor humidity levels when they reach specified setpoints. These measures include passive dehumidification and active dehumidification.

Passive Dehumidification

Passive dehumidification means that the system will modify normal operation measures to reduce and extract humidity from the space, without generating any extra demand on the system. These measures include limiting the economizer from allowing outdoor humidity into the indoor space, disabling the high sensible blower setting to allow for more latent heat removal and enabling a slower blower speed than nominal, when applicable, to increase the latent heat removal capability. Passive dehumidification turns on when the indoor humidity rises above the passive dehum setpoint and shuts off after the indoor humidity level falls below the dehum off setpoint.

Active Dehumidification

Active dehumidification means that the system will take extra measures to extract humidity from the indoor space. Active dehumidification will work with passive dehumidification but will use one unit that is capable to heat and cool the space in a cycle with reduced blower speeds to extract the most moisture from the indoor room. Active dehumidification turns on when the indoor humidity rises above the active dehum setpoint and shuts off after the indoor humidity level falls below the dehum off setpoint.

To adjust the dehumidification setpoints:

1. Press MENU key to go to the Main Menu screen.
2. Press UP or DOWN keys and ENTER key to enter USER password 2000.
3. Press UP or DOWN keys to scroll to **Sys Config**; press ENTER key.
4. Press UP or DOWN keys to scroll to **Unit Setup (A4)**; press ENTER key.
5. Press ENTER key to scroll to **Dehum Off** (see Figure 28).
6. Press UP or DOWN keys to adjust value.
7. Press ENTER key to scroll to **Passive On**.
8. Press UP or DOWN keys to adjust value.
9. Press ENTER key to scroll to **Active On**.
10. Press UP or DOWN keys to adjust value.
11. Press ENTER key to save.
12. Press the ESCAPE key several times to return to Main Menu screen.

FIGURE 28
Adjusting Dehumidification Setpoints

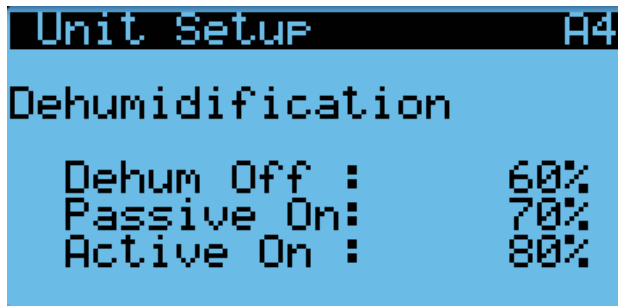

Fan Control

The LV has the option to change the continuous blower setting of the units connected to it. The options are All, Lead and None. If the option is set to All, then all of the units connected will run the blower continuously. If the option is set to Lead, only the unit in the lead position will run the blower continuously. If the option is set to None, then none of the units will run the blower continuously. When continuous blower doesn't apply to a unit, it will cycle the blower based on heating or cooling calls.

To adjust the continuous fan setting:

1. Press MENU key to go to the Main Menu screen.
2. Press UP or DOWN keys and ENTER key to enter USER password 2000.
3. Press UP or DOWN keys to scroll to **Sys Config**; press ENTER key.

4. Press UP or DOWN keys to scroll to **Unit Setup (A1)**; press ENTER key.
5. Press ENTER key to scroll to **Continuous Fan** (see Figure 29).
6. Press UP or DOWN keys to adjust value.
7. Press ENTER key to save.
8. Press the ESCAPE key several times to return to Main Menu screen.

FIGURE 29
Adjusting Continuous Fan Setting

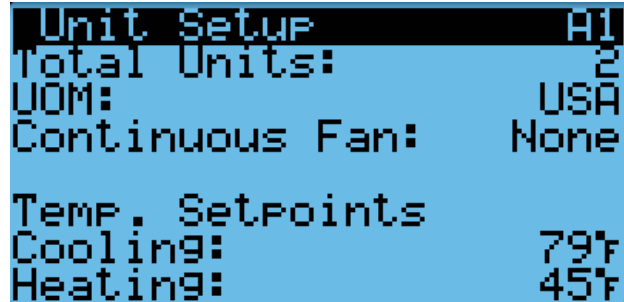

Hour Counting

The LV will keep track of each unit's heating and cooling method run times for last 24 hours (see Figure 30). In addition to how long an item was on, it will also track how many times a method started. These screens are located in the Quick Menu Info screens.

FIGURE 30
Last 24 Hours Tracking



8403-079 Remote Indoor Temperature/Humidity Sensor

FIGURE 31
8403-079 Sensor

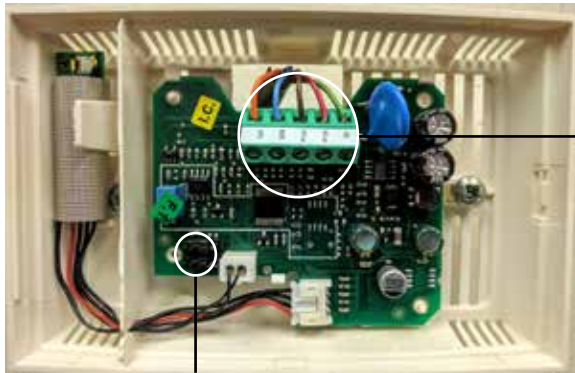

Sensor Terminals	Description
M(GO) - +(G)	12VDC +/-
M(GO) - OUT H	0-1VDC (see Voltage/Humidity chart)
NTC OUT - NTC OUT	Ohm (see Temperature/Resistance chart)

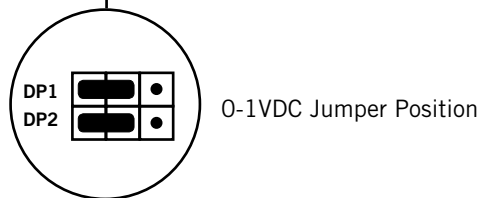

TABLE 7
8403-079 Sensor: Voltage/Humidity

Voltage DC	RH%	Voltage DC	RH%	Voltage DC	RH%
1	100	0.66	66	0.32	32
0.99	99	0.65	65	0.31	31
0.98	98	0.64	64	0.30	30
0.97	97	0.63	63	0.29	29
0.96	96	0.62	62	0.28	28
0.95	95	0.61	61	0.27	27
0.94	94	0.60	60	0.26	26
0.93	93	0.59	59	0.25	25
0.92	92	0.58	58	0.24	24
0.91	91	0.57	57	0.23	23
0.90	90	0.56	56	0.22	22
0.89	89	0.55	55	0.21	21
0.88	88	0.54	54	0.20	20
0.87	87	0.53	53	0.19	19
0.86	86	0.52	52	0.18	18
0.85	85	0.51	51	0.17	17
0.84	84	0.50	50	0.16	16
0.83	83	0.49	49	0.15	15
0.82	82	0.48	48	0.14	14
0.81	81	0.47	47	0.13	13
0.80	80	0.46	46	0.12	12
0.79	79	0.45	45	0.11	11
0.78	78	0.44	44	0.10	10
0.77	77	0.43	43	0.09	9
0.76	76	0.42	42	0.08	8
0.75	75	0.41	41	0.07	7
0.74	74	0.40	40	0.06	6
0.73	73	0.39	39	0.05	5
0.72	72	0.38	38	0.04	4
0.71	71	0.37	37	0.03	3
0.70	70	0.36	36	0.02	2
0.69	69	0.35	35	0.01	1
0.68	68	0.34	34	0.00	0
0.67	67	0.33	33		

LV1000 MODBUS TCP REGISTER LIST

Version 1.1

For use with the following devices: LVS1000.1.1.0, LVS1000.1.1.1, LVS1000.2.0.0

Input Registers (Read Only)

The following input registers reflect system inputs, operation variables and alarm setpoints for read-only purposes. (Units are represented as a whole number but include a single decimal place, i.e., a value of 600 through Modbus equals a value of 60.0 in the LV1000 system.)

Input Registers (Read Only System Values and Setpoints)	
Index	Description
0	Indoor Temperature Sensor 1
1	Indoor Temperature Sensor 2 (if used)
2	Indoor Temperature Sensor 3 (if used)
3	Indoor Temperature Average
4	Indoor Humidity Sensor 1
5	Indoor Humidity Sensor 2 (if used)
6	Indoor Humidity Sensor 3 (if used)
7	Indoor Humidity Average
10	Cooling Setpoint
11	Heating Setpoint
12	High Temperature Warning Setpoint
13	High Temperature Alarm Setpoint
14	Low Temperature Setpoint
16	Number of Units in System
17	Lead Unit in Rotation
18	Lag Unit 1 in Rotation
19	Lag Unit 2 in Rotation
20	Lag Unit 3 in Rotation

Holding Registers (Read/Write)

The following holding registers reflect system setpoints that can be changed via Modbus TCP. (Units are represented as a whole number but include a single decimal place, i.e., a value of 600 through Modbus equals a value of 60.0 in the LV1000 system.)

Holding Registers (Writable Setpoints)	
Index	Description
0	Cooling Setpoint
1	Heating Setpoint
2	Low Temperature Setpoint
3	High Temperature Warning Setpoint
4	High Temperature Alarm Setpoint
5	Low Humidity Alarm Setpoint
6	High Humidity Alarm Setpoint
7	Free Cooling Outdoor Temperature Setpoint
8	Free Cooling Outdoor Humidity Setpoint
9	Free Cooling Outdoor Dew Point Setpoint
10	Modbus TCP Unit of Measure 0 = No Conversion 1 = SI 2 = US Customary 3 = Imperial 4 = Canadian Customary 5 = LON Units
11	1 = Unit Manual Rotation (Resets back to 0 after rotation)

Discrete Inputs (Read Only)

The following discrete inputs reflect system alarms, major unit alarms and unit staging operations.

Discrete Inputs (Read Only Alarms and System Operation)	
Index	Description
0	= 1 when smoke alarm is active
1	= 1 when hydrogen alarm is active
2	= 1 when generator is running
3	= 1 when anti-theft (Bard Guard) is alarming
5	= 1 when indoor temp falls below Low Temp Alarm setpoint
6	= 1 when indoor temp rises above High Temperature Warning setpoint
7	= 1 when indoor temp rises above High Temperature Alarm setpoint
8	= 1 when HVAC Fail is detected on any unit
9	= 1 when HVAC Fail is condition is active on Unit 1
10	= 1 when HVAC Fail is condition is active on Unit 2
11	= 1 when HVAC Fail is condition is active on Unit 3
12	= 1 when HVAC Fail is condition is active on Unit 4
13	= 1 when any unit requires maintenance
14	= 1 when Unit 1 is detected by the LV1000
15	= 1 when Unit 2 is detected by the LV1000
16	= 1 when Unit 3 is detected by the LV1000
17	= 1 when Unit 4 is detected by the LV1000
20	= 1 when Unit 1 has a call for Free Cooling (if available)
22	= 1 when Unit 1 has a call for Cooling Stage 1
23	= 1 when Unit 1 has a call for Cooling Stage 2
26	= 1 when Unit 1 has a call for Free Heating Stage 1 (if available)
27	= 1 when Unit 1 has a call for Free Heating Stage 2 (if available)
28	= 1 when Unit 1 has a call for Free Heating Stage 3 (if available)
31	= 1 when Unit 2 has a call for Free Cooling (if available)
33	= 1 when Unit 2 has a call for Cooling Stage 1
34	= 1 when Unit 2 has a call for Cooling Stage 2
37	= 1 when Unit 2 has a call for Free Heating Stage 1 (if available)
38	= 1 when Unit 2 has a call for Free Heating Stage 2 (if available)
39	= 1 when Unit 2 has a call for Free Heating Stage 3 (if available)
42	= 1 when Unit 3 has a call for Free Cooling (if available)
44	= 1 when Unit 3 has a call for Cooling Stage 1
45	= 1 when Unit 3 has a call for Cooling Stage 2

Discrete Inputs (Read Only) cont.

Discrete Inputs (Read Only Alarms and System Operation)	
Index	Description
48	= 1 when Unit 3 has a call for Free Heating Stage 1 (if available)
49	= 1 when Unit 3 has a call for Free Heating Stage 2 (if available)
50	= 1 when Unit 3 has a call for Free Heating Stage 3 (if available)
53	= 1 when Unit 4 has a call for Free Cooling (if available)
55	= 1 when Unit 4 has a call for Cooling Stage 1
56	= 1 when Unit 4 has a call for Cooling Stage 2
59	= 1 when Unit 4 has a call for Free Heating Stage 1 (if available)
60	= 1 when Unit 4 has a call for Free Heating Stage 2 (if available)
61	= 1 when Unit 4 has a call for Free Heating Stage 3 (if available)
100	= 1 when Unit 1 Low Pressure Alarm is active
101	= 1 when Unit 1 High Pressure Cut-Out is active
102	= 1 when Unit 1 economizer damper failed to close
103	= 1 when Unit 1 economizer damper failed to open
104	= 1 when Unit 1 blower failure
200	= 1 when Unit 2 Low Pressure Alarm is active
201	= 1 when Unit 2 High Pressure Cut-Out is active
202	= 1 when Unit 2 economizer damper failed to close
203	= 1 when Unit 2 economizer damper failed to open
204	= 1 when Unit 2 blower failure
300	= 1 when Unit 3 Low Pressure Alarm is active
301	= 1 when Unit 3 High Pressure Cut-Out is active
302	= 1 when Unit 3 economizer damper failed to close
303	= 1 when Unit 3 economizer damper failed to open
304	= 1 when Unit 3 blower failure
400	= 1 when Unit 4 Low Pressure Alarm is active
401	= 1 when Unit 4 High Pressure Cut-Out is active
402	= 1 when Unit 4 economizer damper failed to close
403	= 1 when Unit 4 economizer damper failed to open
404	= 1 when Unit 4 blower failure

TABLE 8
LV1000-200 Terminal Block Index

TB#	Wire Mark	Description
1	48+	48VDC +Input
2	48-	48VDC - Input
3	GND	Ground
4	24+	24VDC +
5	24-	24VDC -
6	24+	24VDC +
7	24-	24VDC -
8	DI1	Smoke Detector Input
9	GND	Smoke Detector Common
10	DI2	Hydrogen Detector Input
11	GND	Hydrogen Detector Common
12	DI3	Generator Run Input
13	GND	Generator Run Common
14	DI4	Anti Theft Input
15	GND	Anti Theft Common
16	DI5	Inverter Fault Input
17	GND	Inverter Fault Common
18	B2	Humidity Sensor 1
19	GND	Ground
20	B3	Humidity Sensor 2
21	GND	Ground
22	B4	Humidity Sensor 3
23	GND	Ground

TB#	Wire Mark	Description
24	B6	Remote Temperature Sensor 1
25	GND	Ground
26	B7	Remote Temperature Sensor 2
27	GND	Ground
28	B8	Remote Temperature Sensor 3
29	GND	Ground
30	VDC+	Humidity Sensor 1 +24VDC (B2)
31	VDC+	Humidity Sensor 2 +24VDC (B3)
32	VDC+	Humidity Sensor 3 +24VDC (B4)
33	VDC+	Spare Power +24VDC
34	NO1	Humidifier Output Relay
35	C1	Common
36	NO2	HVAC Fail
37	C1	Common
38	NO3	HVAC Maintenance
39	C1	Common
40	NO4	HVAC Anti Theft
41	C2	Common
42	FB1R-	RS485 RX- / TX- (Wall Units)
43	FB1R+	RS485 RX+ / TX+ (Wall Units)
44	FB2R-	RS485 RX- / TX- (Fieldbus 1)
45	FB2R+	RS485 RX+ / TX+ (Fieldbus 1)
46	-	Ground

FIGURE 32
LV1000-200 Wiring Diagram

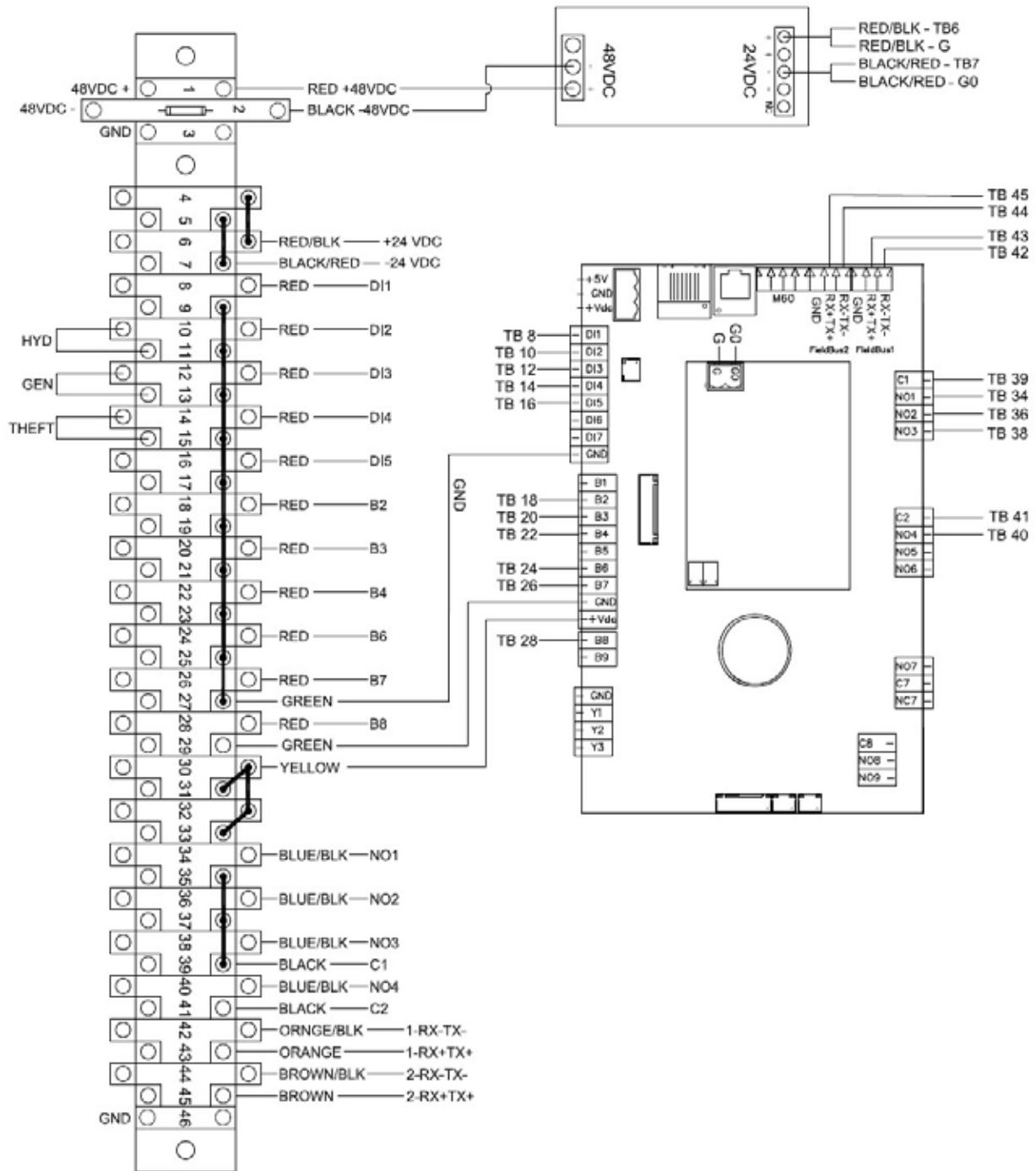

LV1000 REPLACEMENT PARTS

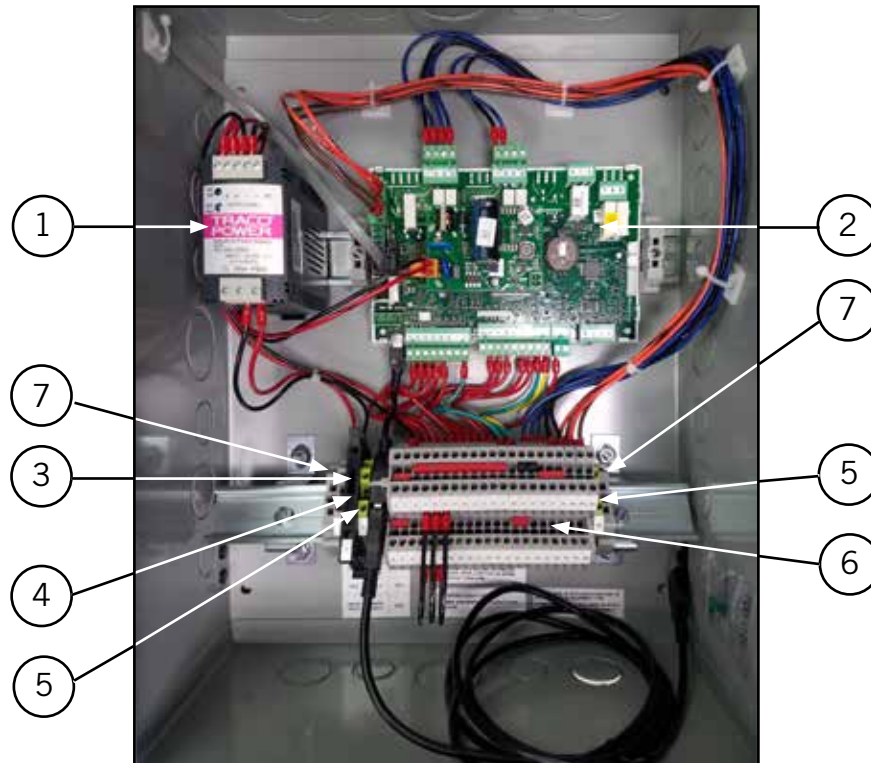

Dwg. No.	Part Number	Description	LV1000
1	8301-082	17 – 75VDC to 24VDC Converter 2.5 Amps	1
2	8301-085-001*	UPC3-LV1000	1
3	8614-059	1.0 Amp Fuse	1
4	8607-039	Fused Terminal Block	1
5	8607-052	Grounded Terminal Block	2
6	8607-058	Terminal Block Double Level	21
7	8611-144	End Clamp (for din rail)	4
NS	8301-053	Panel Mounting Display Flush, pGDEvolution 132x64, Black Buttons with Cable	1
NS	3020-010	35' 2 Conductor 18 Gauge Cable	1
NS	8301-055	EMI Ferrite Filter	2
NS	8301-058	Remote Temperature Sensor ①	1
NS	8403-079	Remote Temperature/Humidity Sensor	1
NS	8301-059	TEC-EYE (Service Tool), 5' Telephone Cable	1
NS	3000-1587	5' Telephone Cable	1

* Replacement part will have a letter attached to the end of the part number to designate software version (Example: 8301-085-001**A**). A software upgrade of all PLCs onsite (units and controllers) should accompany any PLC replacement. Latest revisions of software, change log and instructions are available on the Bard website at <http://www.bardhvac.com/software-download/>

① Optional

NS – Not Shown